

GS2911

300mA CMOS Positive LDO Voltage Regulator

Product Description

The GS2911 is a positive voltage output, three-pin regulator that provides a high current even when the input/output voltage differential is small. Low power consumption and high accuracy is achieved through CMOS and laser trimming technologies.

The GS2911 consists of a high-precision voltage reference, an error correction circuit, and a current limited output driver. Transient response to load variations has improved in comparison to the existing series.

TO-92 and SOT-89 packages are available.

Features	Applications
<ul style="list-style-type: none"> ■ Maximum output current: 250mA (within the maximum power dissipation, $V_{OUT}=5.0V$) ■ Output voltage: 2.0V to 6.0V in 0.1V increments (1.1V to 1.9V for custom products) ■ Highly accurate: Output voltage $\pm 2\%$ ($\pm 1\%$ for semi-custom products) ■ Low power consumption: Typ. 2.0μA at $V_{OUT} = 5.0V$ ■ Output voltage temperature coefficient 0.1%/V: Typ. $\pm 100ppm/^{\circ}C$ ■ Input stability: Typ. 2.0%/V ■ Small input/output differential: $I_{OUT} = 100mA$ at $V_{OUT} = 5.0V$ with a 0.12V differential. ■ SOT-89 and TO-92 packages are available 	<ul style="list-style-type: none"> ■ Wireless Communication Systems ■ Battery Powered Systems ■ Palmtops ■ Portable Cameras and Video Recorders ■ Voltage Regulator for Microprocessor ■ Voltage Regulator for CD-ROM Drivers, LAN Cards, 56K Modem

Block Diagram

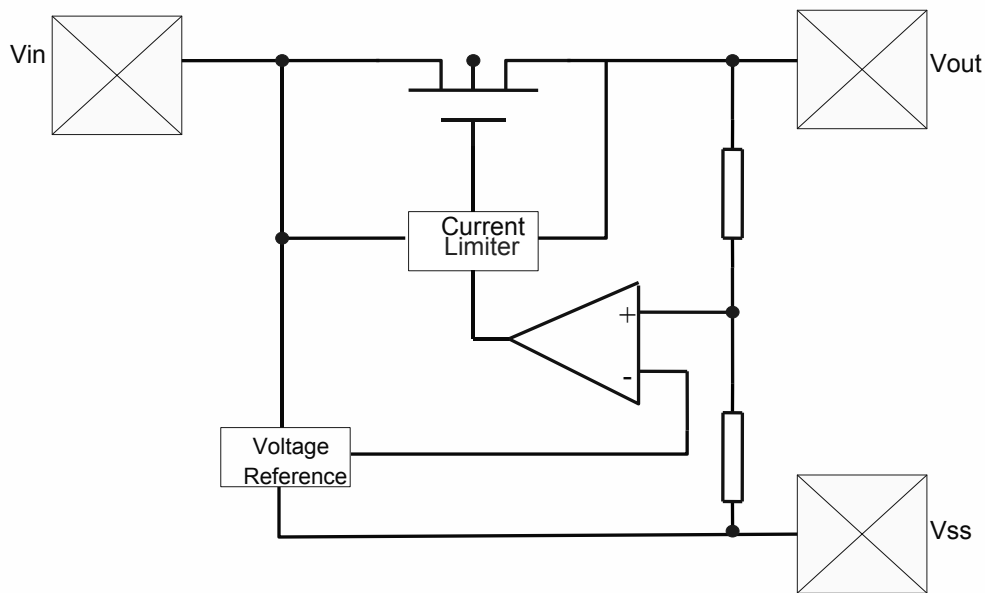

Package and Pin Assignments

GS2911YXX (SOT-89)



Pin1 = GND

Pin2 = V_{IN}

Pin3 = V_{OUT}

GS2911NXX (TO-92)

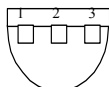

Pin1 = GND

Pin2 = V_{IN}

Pin3 = V_{OUT}

Ordering Information

SOT-89	TO-92	Output
GS2911Y15	GS2911N15	1.5V
GS2911Y18	GS2911N18	1.8V
GS2911Y20	GS2911N20	2.0V
GS2911Y25	GS2911N25	2.5V
GS2911Y33	GS2911N33	3.3V
GS2911Y50	GS2911N50	5.0V

*For additional available fixed voltages contact factory.

*Add "F" means lead free part.

Absolute Maximum Ratings

Parameter	Symbol	Ratings
Input Voltage	V_{IN}	12V
Output Current	I_{OUT}	500 mA
Output Voltage	V_{OUT}	$V_{SS}-0.3$ to $V_{IN}+0.3$
Continuous Total Power Dissipation TO-92 SOT-89	P_D	500 mW 550 mW
Operating Ambient Temperature	T_{opr}	0°C to 80°C
Storage temperature Range	T_{stg}	-40°C to 125°C
Lead Temperature (10 sec)	T_{LEAD}	260°C

Electrical Characteristics $V_{OUT(T)} = 2.0$ (Note 1)

Parameter	Symbol	Conditions	Min	Typ.	Max	Unit
Output voltages	$V_{OUT(E)}$ (Note 2)	$I_{OUT} = 40mA$ $V_{IN} = 3.0V$	1.960	2.000	2.040	V
Maximum output current	$I_{OUT\ max}$	$V_{IN} = 3.0V$ $V_{OUT(E)} \geq 1.8V$	100			mA
Load stability	ΔV_{OUT}	$V_{IN} = 3.0V$ $1mA \leq I_{OUT} \leq 60mA$		45	90	mV
Input-Output Voltage differential (Note 3)	V_{dif}	$I_{OUT} = 60mA$		180	360	mV
		$I_{OUT} = 120mA$		400	700	mV
Supply current	I_{SS}	$V_{IN} = 3.0V$		1.0	100	μA
Line regulation	$\frac{\Delta V_{OUT}}{\Delta V_{IN} * \Delta V_{OUT}}$	$I_{OUT} = 40mA$ $3.0V \leq V_{IN} \leq 10.0V$		0.2	0.3	%/V
Input voltage	V_{IN}				10	V
Output voltage Temperature characteristics	$\frac{\Delta V_{OUT}}{\Delta T_{opr} * \Delta V_{OUT}}$	$I_{OUT} = 40mA$ $-40^\circ C \leq T_{opr} \leq 85^\circ C$		± 100		ppm/°C

Electrical Characteristics $V_{OUT(T)} = 2.5V$ (Note 1)

Parameter	Symbol	Conditions	Min	Typ.	Max	Unit
Output voltages	V_{OUT} (E) (Note 2)	$I_{OUT} = 40mA$ $V_{IN} = 3.5V$	2.450	2.500	2.550	V
Maximum output current	I_{OUT} max	$V_{IN} = 3.5V$ $V_{OUT(E)} \geq 2.25V$	150			mA
Load stability	ΔV_{OUT}	$V_{IN} = 3.5V$ $1mA \leq I_{OUT} \leq 80mA$		45	90	mV
Input-Output	Vdif	$I_{OUT} = 80mA$		180	360	mV
Voltage differential (Note 3)		$I_{OUT} = 160mA$		400	700	mV
Supply current	I _{ss}	$V_{IN} = 3.5V$		1.0	100	μA
Line regulation	$\frac{\Delta V_{OUT}}{\Delta V_{IN} * \Delta V_{OUT}}$	$I_{OUT} = 40mA$ $3.5V \leq V_{IN} \leq 10.0V$		0.2	0.3	%/V
Input voltage	V_{IN}				10	V
Output voltage Temperature characteristics	$\frac{\Delta V_{OUT}}{\Delta T_{opr} * \Delta V_{OUT}}$	$I_{OUT} = 40mA$ $-40^{\circ}C \leq T_{opr} \leq 85^{\circ}C$		± 100		ppm/°C

Electrical Characteristics $V_{OUT(T)} = 3.3$ (Note 1)

Parameter	Symbol	Conditions	Min	Typ.	Max	Unit
Output voltages	V_{OUT} (E) (Note 2)	$I_{OUT} = 40mA$ $V_{IN} = 4.3V$	3.234	3.3	3.366	V
Maximum output current	I_{OUT} max	$V_{IN} = 4.3V$ $V_{OUT(E)} \geq 2.97V$	165			mA
Load stability	ΔV_{OUT}	$V_{IN} = 4.3V$ $1mA \leq I_{OUT} \leq 80mA$		45	90	mV
Input-Output	Vdif	$V_{IN} = 4.3V$				
Voltage differential (Note 3)		$I_{OUT} = 160mA$		400	700	mV
Supply current	I _{ss}	$V_{IN} = 4.3V$		1.0	100	μA
Line regulation	$\frac{\Delta V_{OUT}}{\Delta V_{IN} * \Delta V_{OUT}}$	$I_{OUT} = 40mA$ $4.3V \leq V_{IN} \leq 10.0V$		0.2	0.3	%/V
Input voltage	V_{IN}				10	V
Output voltage	ΔV_{OUT}	$I_{OUT} = 40mA$		± 100		ppm/°C

Temperature characteristics	$\Delta T_{opr} * \Delta V_{OUT}$	$-40^{\circ}\text{C} \leq T_{opr} \leq 125^{\circ}\text{C}$				
-----------------------------	-----------------------------------	---	--	--	--	--

Electrical Characteristics $V_{OUT(T)} = 5.0$ (Note 1)

Parameter	Symbol	Conditions	Min	Typ	Max	Unit
Output voltages	$V_{OUT(E)}$ (Note 2)	$I_{OUT} = 40\text{mA}$ $V_{IN} = 6.0\text{V}$	4.900	5.000	5.100	V
Maximum output current	$I_{OUT \text{ max}}$	$V_{IN} = 6.0\text{V}$ $V_{OUT(E)} \geq 5.0\text{V}$	165			mA
Load stability	ΔV_{OUT}	$V_{IN} = 6.0\text{V}$ $1\text{mA} \leq I_{OUT} \leq 80\text{mA}$		45	90	mV
Input-Output Voltage differential (Note 3)	V_{dif}	$V_{IN} = 6.0\text{V}$ $I_{OUT} = 200\text{mA}$		380	600	mV
Supply current	I_{SS}	$V_{IN} = 6.0\text{V}$		1.0	100	μA
Line regulation	$\frac{\Delta V_{OUT}}{\Delta V_{IN} * \Delta V_{OUT}}$	$I_{OUT} = 40\text{mA}$ $4.3\text{V} \leq V_{IN} \leq 10.0\text{V}$		0.2	0.3	%/V
Input voltage	V_{IN}				10	V
Output voltage Temperature characteristics	$\frac{\Delta V_{OUT}}{\Delta T_{opr} * \Delta V_{OUT}}$	$I_{OUT} = 40\text{mA}$ $-40^{\circ}\text{C} \leq T_{opr} \leq 125^{\circ}\text{C}$		± 100		ppm/ $^{\circ}\text{C}$

Note1. $V_{OUT(T)}$ = Specified output voltage.

Note2. $V_{OUT(E)}$ = Effective output voltage (i.e. the output voltage when " $V_{OUT(T)}+1.0\text{V}$ " is provided at the V_{IN} pin while maintaining a certain I_{OUT} value.)

Note3. $V_{dif} = (V_{IN1} \text{ (Note 4)} - V_{OUT(E)})$

Note4. V_{IN1} = The input voltage at the time 98% of $V_{OUT(E)}$ is output (input voltage has been gradually reduced).

Typical Performance Characteristics

Output Voltage vs. Output Current

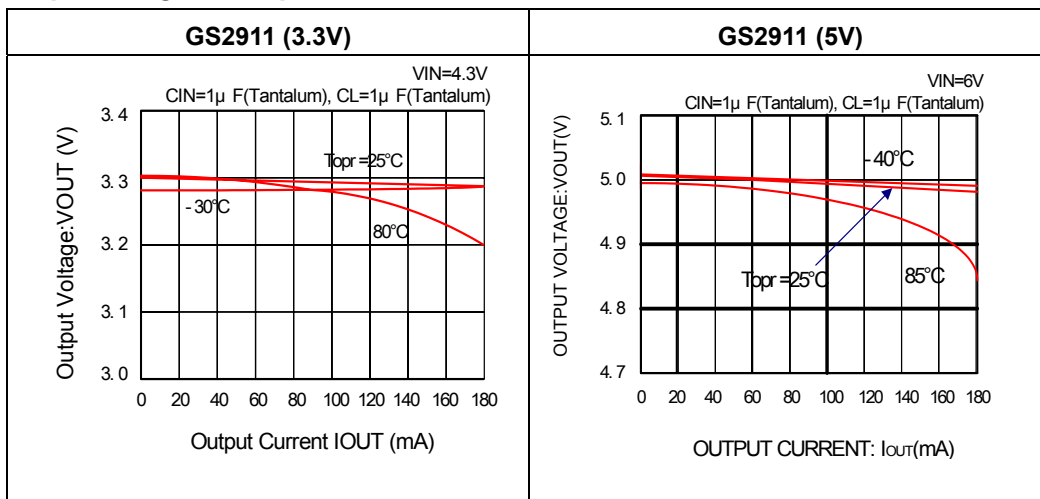

Output Voltage vs. Input Voltage

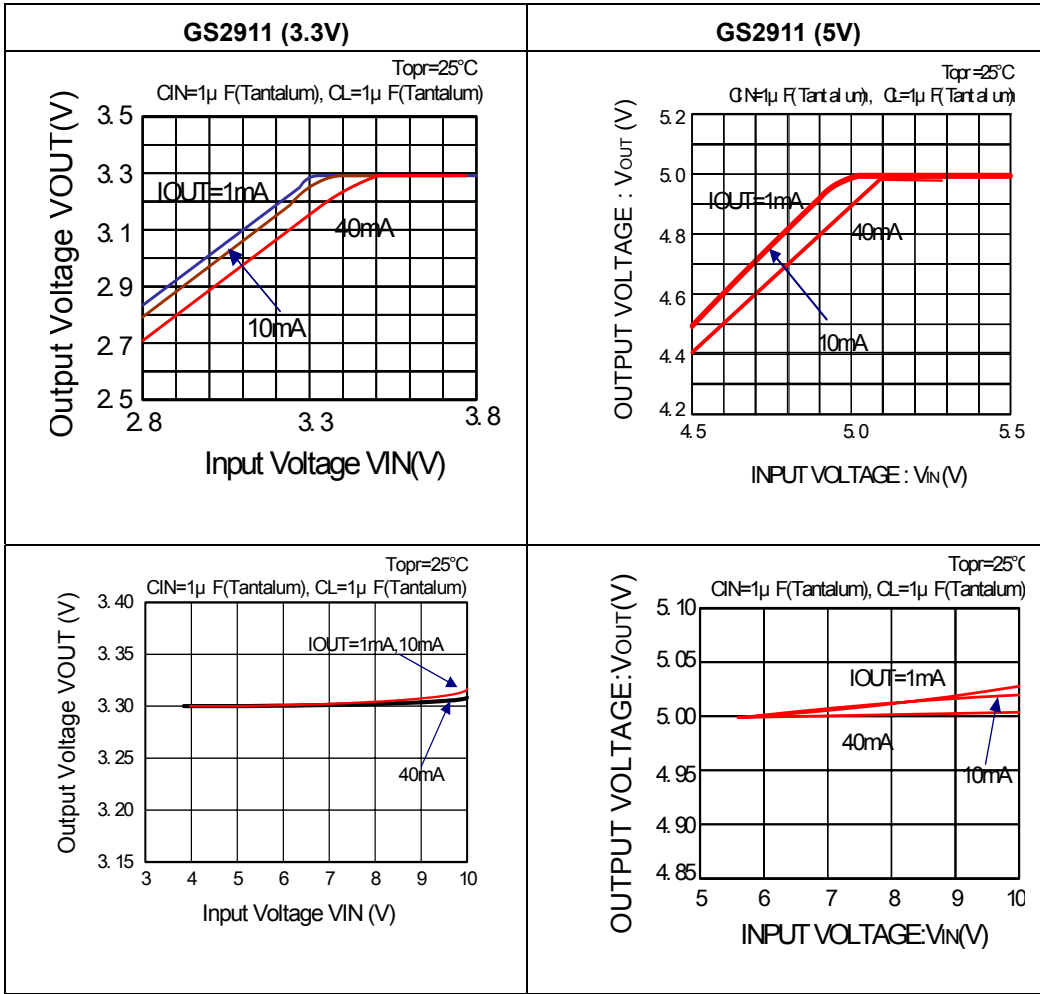

Input/Output Voltage Differential vs. Output Current

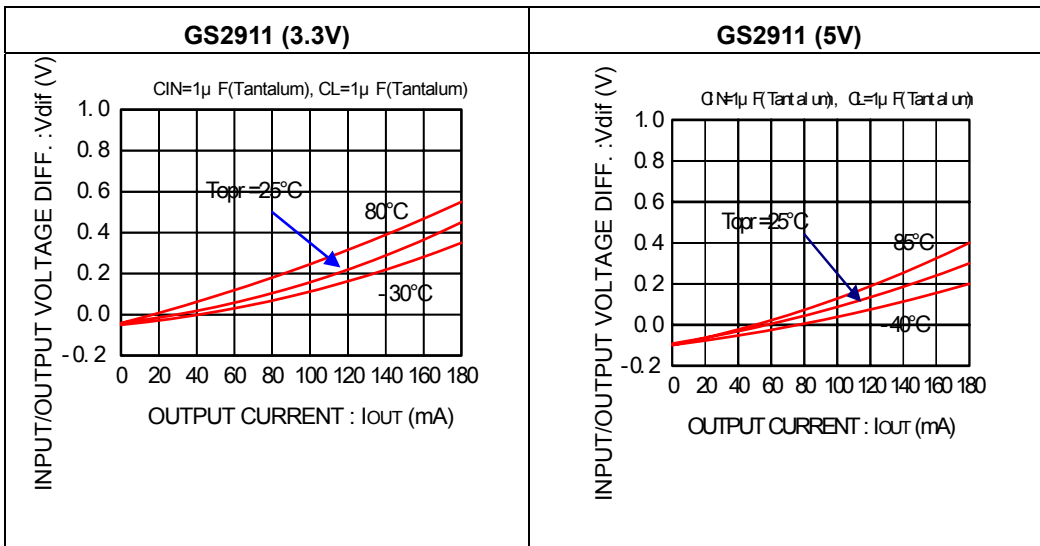

Supply Current vs. Input Voltage

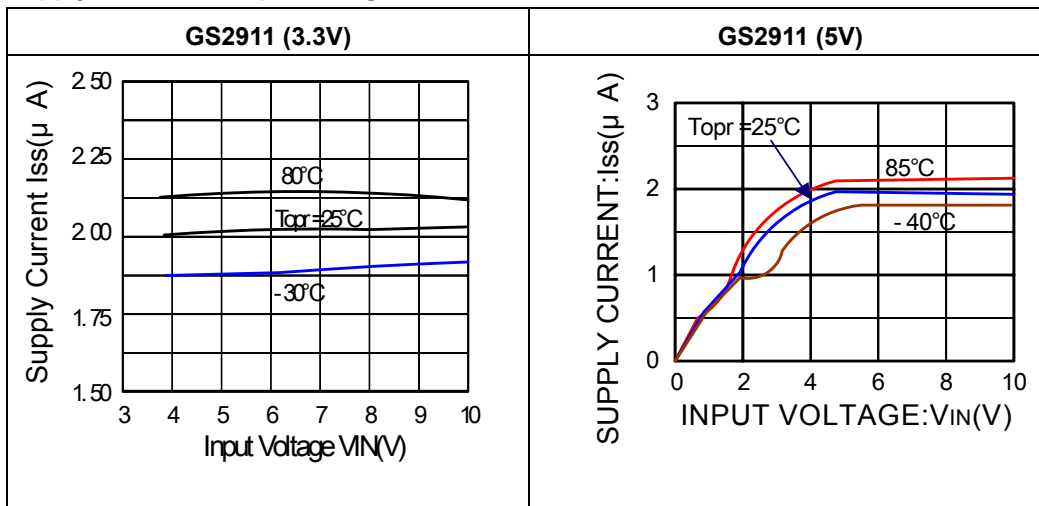

Load Transient Response

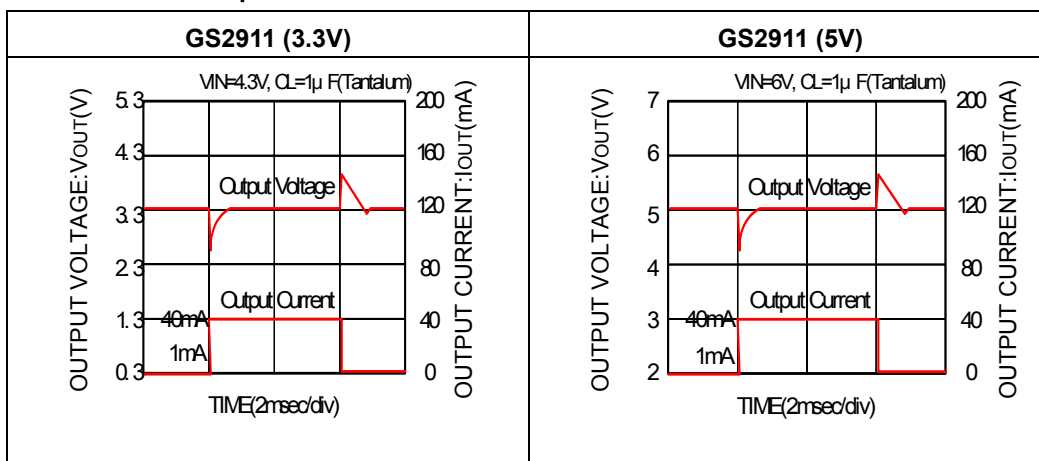

Typical Application Circuits

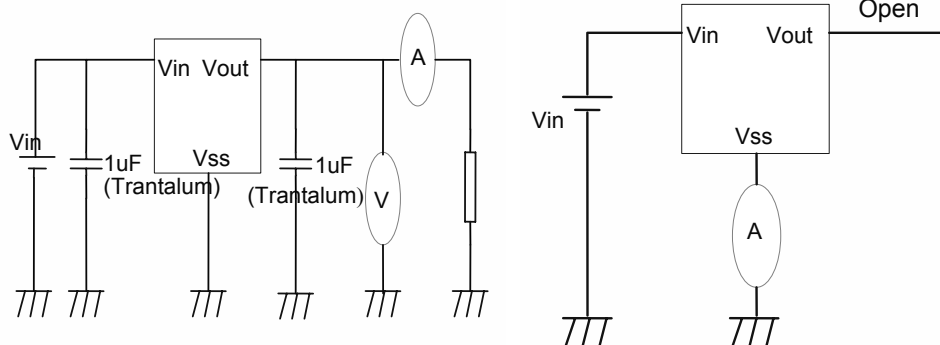

Notes on Use

1. There is a possibility that oscillation may occur as a result of the impedance present between the power supply and the IC's input. Where impedance is 10Ω or more, please use a capacitor (C_{IN}) of at least $1\mu\text{F}$. With a large output current, operations can be stabilised by increasing capacitor size (C_{IN}). If C_{IN} is small and capacitor size (CL) is increased, there is a possibility of oscillation due to input impedance. In such cases, either increasing the size of C_{IN} or decreasing the size of CL can stabilize operations.
2. Please ensure that output current (I_{OUT}) is less than $P_D + (V_{IN} - V_{OUT})$ and does not exceed the stipulated Continuous Total Power Dissipation value (P_D).
3. Should you wish to increase output current (I_{OUT}) and/or have the capability to exceed the stipulated P_D value, using a current boost circuit (similar to the one shown below) is likely to lead to oscillation. With such applications, we recommend use of a boost type voltage regulator, such as the GS2911 series.

Package Dimension

SOT-89 PLASTIC PACKAGE

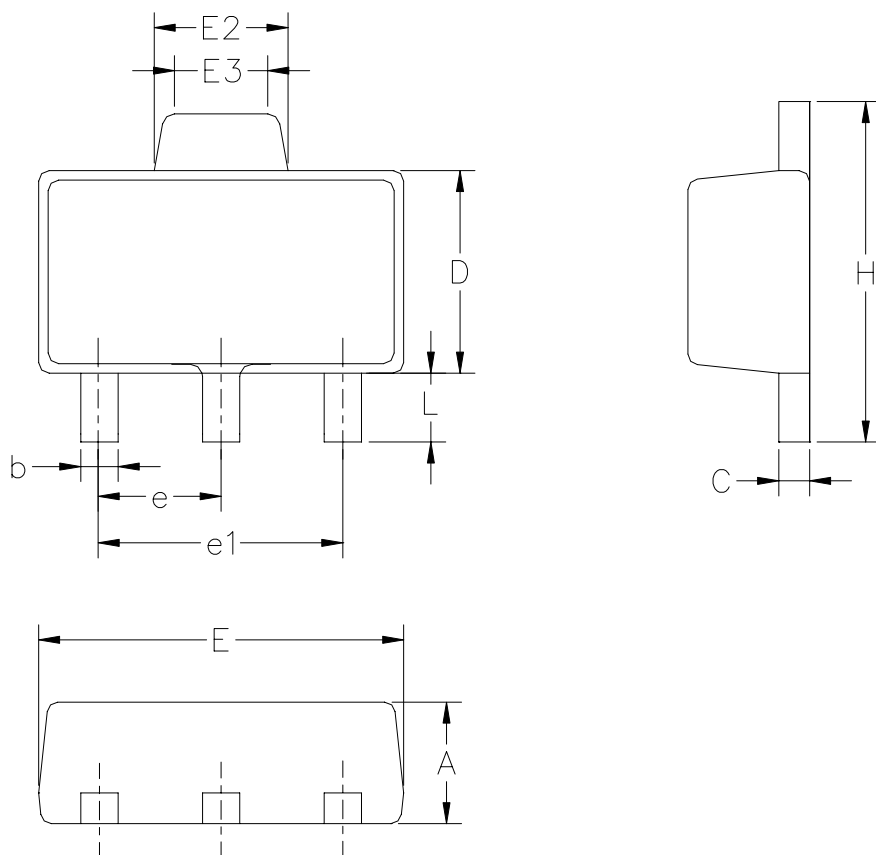

Symbol	Dimensions In Millimeters		Dimensions In Inches	
	Min	Max	Min	Min
A	1.450	1.550	0.570	0.061
b	0.440	0.480	0.017	0.019
C	0.360	0.400	0.014	0.016
E	4.450	4.550	0.175	0.179
E2	1.500	1.700	0.059	0.067
E3	1.400Ref		0.055Ref	
e	1.500BSC		0.059BSC	
e1	3.000BSC		0.118BSC	
H	4.150	4.250	0.163	0.167
D	2.450	2.550	0.096	0.100
L	0.900	1.100	0.035	0.043

TO-92 PLASTIC PACKAGE

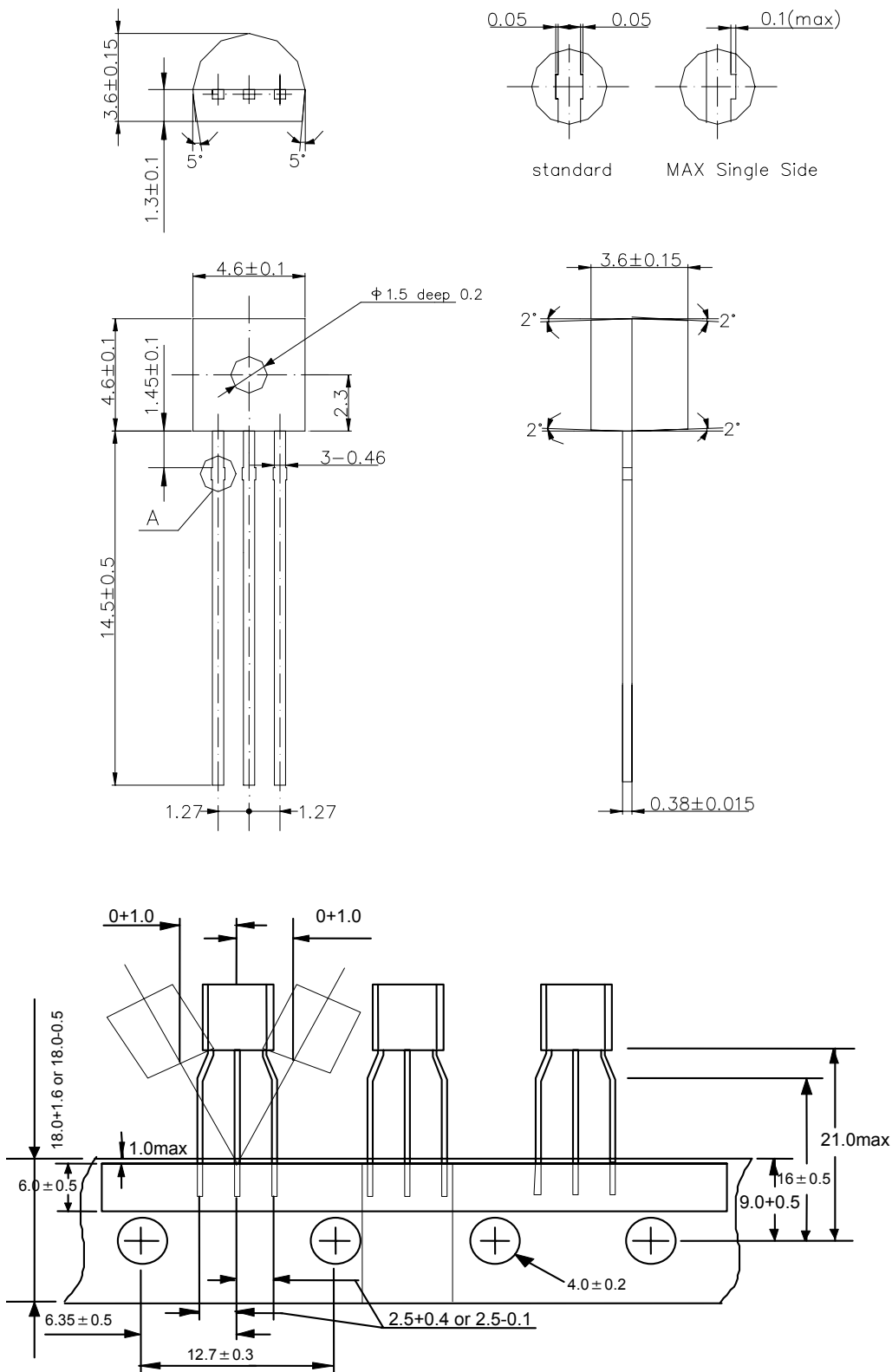

Information furnished is believed to be accurate and reliable. However Globaltech Semiconductor assumes no responsibility for the consequences of use of such information nor for any infringement of patents or other rights of third parties, which may result from its use. No license is granted by implication or otherwise under any patent or patent rights of Globaltech Semiconductor. Specifications mentioned in this publication are subject to change without notice. This publication supersedes and replaces all information without express written approval of Globaltech Semiconductor.