

Synchronous Rectified Buck MOSFET Drivers

General Description

The RT9611A/B is a high frequency, synchronous rectified, single phase dual MOSFET driver designed to adapt from normal MOSFET driving applications to high performance CPU VR driving capabilities.

The RT9611A/B can be utilized under both $V_{CC} = 5V$ or $V_{CC} = 12V$ applications. The RT9611A/B also builds in an internal power switch to replace external boot strap diode. The RT9611A/B can support switching frequency efficiently up to 500kHz. The RT9611A/B has the UGATE driving circuit and the LGATE driving circuit for synchronous rectified DC/DC converter applications. The driving rise/fall time capability is designed within 30ns and the shoot through protection mechanism is designed to prevent shoot through of high side and low side power MOSFETs. The RT9611A/B has PWM tri-state shut down and \overline{OD} input shut down functions which can force driver output into high impedance.

The difference of the RT9611A and the RT9611B is the propagation delay, $t_{UGATEpdh}$. The RT9611B has comparatively large $t_{UGATEpdh}$ than RT9611A. Hence, the RT9611A is usually recommended to be utilized in performance oriented applications, such as high power density CPU VR or GPU VR.

The RT9611A/B comes in a small footprint with 8-pin packages. The choice of packages type includes SOP-8, SOP-8 (Exposed Pad) and WDFN-8EL 3x3.

Features

- Drive Two N-MOSFETs
- Adaptive Shoot Through Protection
- Embedded Bootstrap Diode
- Support High Switching Frequency
- Fast Output Rise Time
- Tri-State Input for Bridge Shutdown
- Disable Control Input
- Small SOP-8, SOP-8 (Exposed Pad) and 8-Lead WDFN Packages
- RoHS Compliant and Halogen Free

Applications

- Core Voltage Supplies for Desktop, Motherboard CPU
- High Frequency Low Profile DC/DC Converters
- High Current Low Voltage DC/DC Converters

Ordering Information

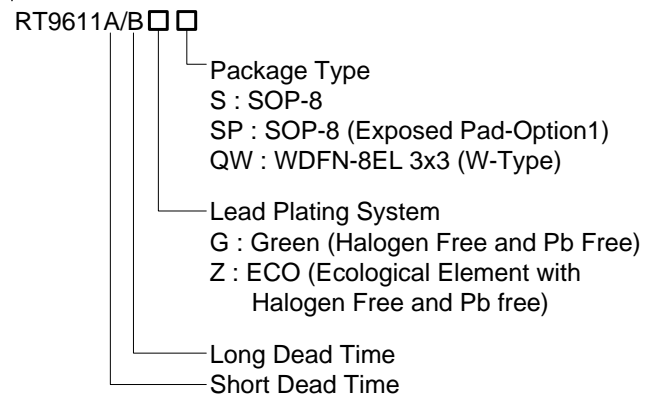

Note :

Richtek products are :

- ▶ RoHS compliant and compatible with the current requirements of IPC/JEDEC J-STD-020.
- ▶ Suitable for use in SnPb or Pb-free soldering processes.

Pin Configurations

(TOP VIEW)

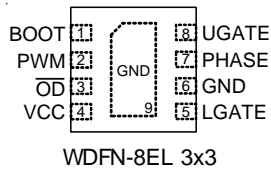
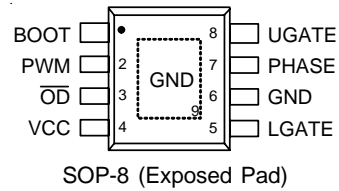
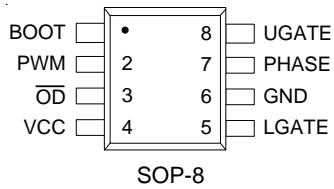

Marking Information

RT9611xGS

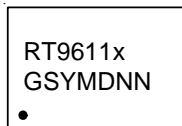

RT9611xGS : Product Number
x: A or B
YMDNN : Date Code

RT9611xGSP

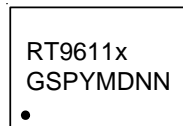

RT9611xGSP : Product Number
x: A or B
YMDNN : Date Code

RT9611xZS

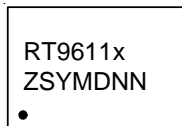

RT9611xZS : Product Number
x: A or B
YMDNN : Date Code

RT9611xZSP

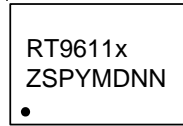

RT9611xZSP : Product Number
x: A or B
YMDNN : Date Code

RT9611AGQW

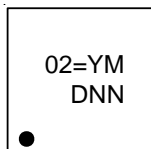

02= : Product Code
YMDNN : Date Code

RT9611BGQW

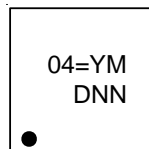

04= : Product Code
YMDNN : Date Code

RT9611AZQW

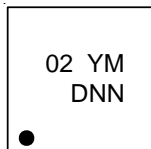

02 : Product Code
YMDNN : Date Code

RT9611BZQW

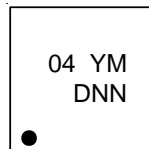

04 : Product Code
YMDNN : Date Code

Typical Application Circuit

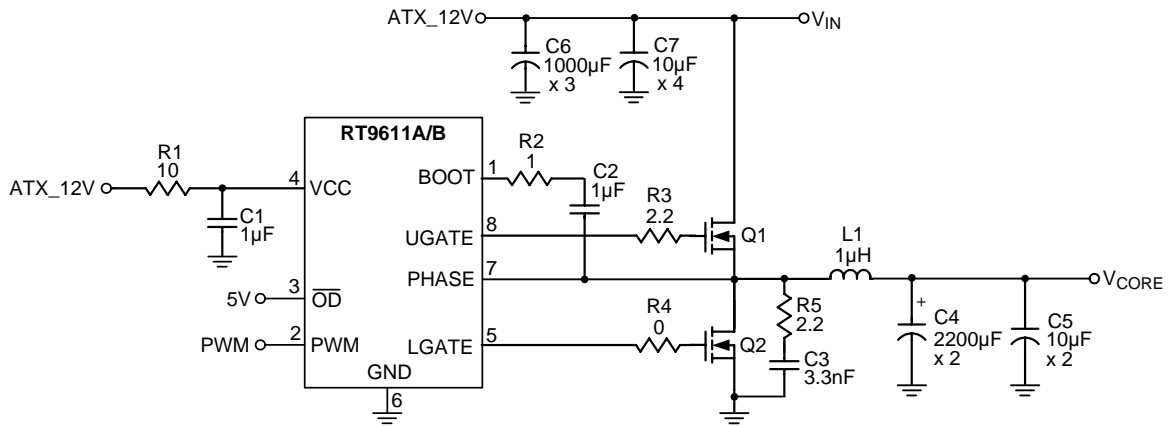

Timing Diagram

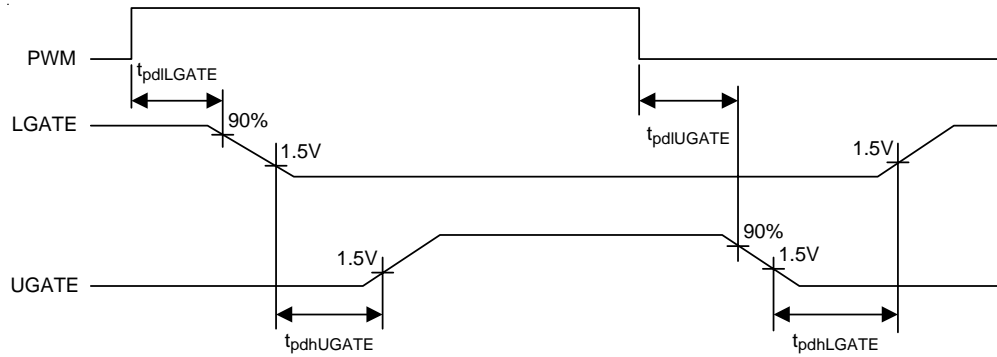

Functional Pin Description

Pin No.		Pin Name	Pin Function
SOP-8	SOP-8 (Exposed Pad) / WDFN-8EL 3x3		
1	1	BOOT	Floating Bootstrap Supply Pin for Upper Gate Driver.
2	2	PWM	Input PWM Signal for Controlling the Driver.
3	3	\overline{OD}	Output Disable. When low, both UGATE and LGATE are driven low and the normal operation is disabled.
4	4	VCC	12V Supply Voltage.
5	5	LGATE	Lower Gate Driver Output. Connected to gate of low side power N-MOSFET.
6	6, 9 (Exposed Pad)	GND	Ground. The exposed pad must be soldered to a large PCB and connected to GND for maximum power dissipation.
7	7	PHASE	Connect this pin to the source of the high side MOSFET and the drain of the low side MOSFET.
8	8	UGATE	Upper Gate Driver Output. Connected this pin to gate of high side power N-MOSFET.

Function Block Diagram

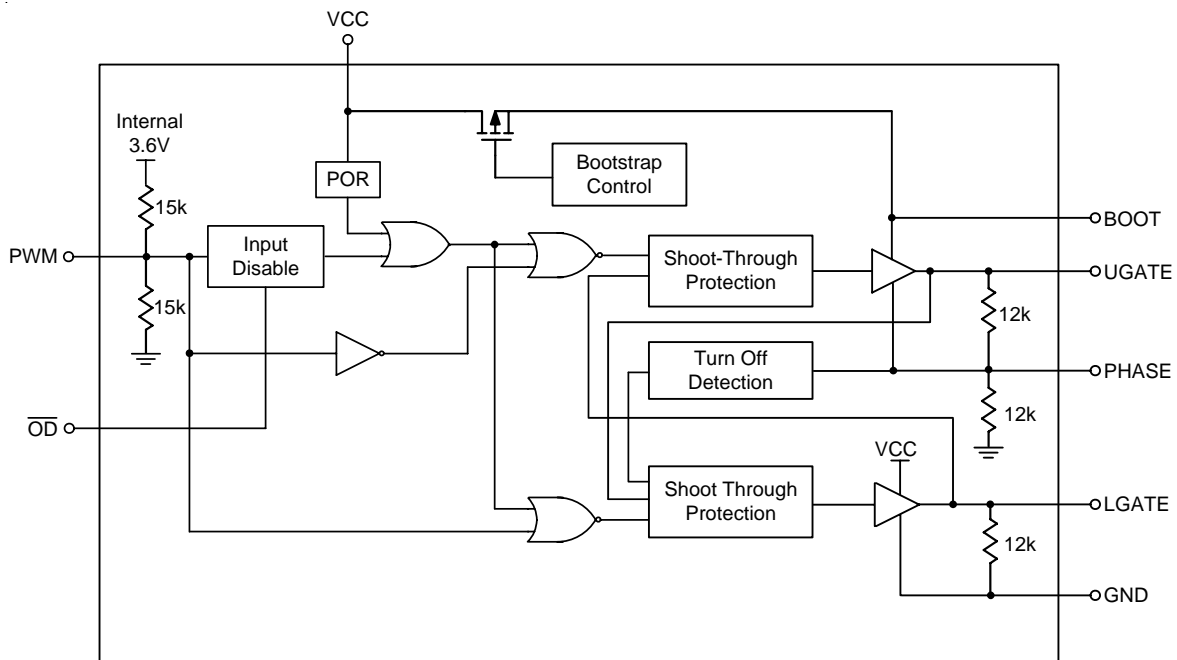

Absolute Maximum Ratings (Note 1)

- Supply Voltage, VCC ----- -0.3V to 15V
- BOOT to PHASE ----- -0.3V to 15V
- PHASE to GND
 - DC ----- -5V to 15V
 - < 200ns ----- -10V to 30V
- LGATE
 - DC ----- (GND - 0.3V) to (V_{CC} + 0.3V)
 - < 200ns ----- -2V to (V_{CC} + 0.3V)
- UGATE ----- (V_{PHASE} - 0.3V) to (V_{BOOT} + 0.3V)
- < 200ns ----- (V_{PHASE} - 2V) to (V_{BOOT} + 0.3V)
- PWM Input Voltage ----- (GND - 0.3V) to 7V
- OD ----- (GND - 0.3V) to 7V
- Power Dissipation, P_D @ T_A = 25°C
 - SOP-8 ----- 0.833W
 - ̄SOP-8 (Exposed Pad) ----- 1.333W
 - WDFN-8EL 3x3 ----- 1.429W
- Package Thermal Resistance (Note 2)
 - SOP-8, θ_{JA} ----- 120°C/W
 - SOP-8 (Exposed Pad), θ_{JA} ----- 75°C/W
 - SOP-8 (Exposed Pad), θ_{JC} ----- 15°C/W
 - WDFN-8EL 3x3, θ_{JA} ----- 70°C/W
 - WDFN-8EL 3x3, θ_{JC} ----- 8.2°C/W
- Lead Temperature (Soldering, 10 sec.) ----- 260°C
- Junction Temperature ----- 150°C
- Storage Temperature Range ----- -65°C to 150°C
- ESD Susceptibility (Note 3)
 - HBM (Human Body Model) ----- 2kV

Recommended Operating Conditions (Note 4)

- Supply Voltage, VCC ----- 12V ±10%
- Junction Temperature Range ----- -40°C to 125°C
- Ambient Temperature Range ----- -40°C to 85°C

Electrical Characteristics

($V_{CC} = 12V$, $T_A = 25^\circ C$, unless otherwise specified)

Parameter	Symbol	Test Conditions	Min	Typ	Max	Unit		
Power Supply Voltage	V_{CC}		4.5	--	13.5	V		
Power Supply Current	I_{VCC}	$V_{BOOT} = 12V$, $PWM = 0V$	--	1.2	--	mA		
Power On Reset								
POR Threshold	V_{POR}	V_{CC} Rising	3	4	4.4	V		
Hysteresis	V_{CC_hys}		--	0.5	--	V		
PWM Input								
Maximum Input Current	I_{PWM}	$PWM = 0V$ or $5V$	--	300	--	μA		
PWM Floating Voltage	V_{PWM_fl}	$V_{CC} = 12V$	1.6	1.8	2	V		
PWM Rising Threshold	V_{PWM_rth}		2.8	--	--	V		
PWM Falling Threshold	V_{PWM_fth}		--	--	0.8	V		
Output Disable Input								
\overline{OD} Rising Threshold	$V_{\overline{OD}_rth}$		1	1.3	1.6	V		
\overline{OD} Hysteresis	$V_{\overline{OD}_hys}$		--	0.3	--	V		
Timing								
UGATE Rise Time	t_{UGATEr}	$V_{CC} = 12V$, 3nF load	--	25	--	ns		
UGATE Fall Time	t_{UGATEf}	$V_{CC} = 12V$, 3nF load	--	12	--	ns		
LGATE Rise Time	t_{LGATEr}	$V_{CC} = 12V$, 3nF load	--	24	--	ns		
LGATE Fall Time	t_{LGATEf}	$V_{CC} = 12V$, 3nF load	--	10	--	ns		
Propagation Delay	RT9611A	$t_{UGATEpdh}$	$V_{BOOT} - V_{PHASE} = 12V$ See Timing Diagram	--	22	--	ns	
	RT9611B			--	60	--		
	RT9611A/B	$t_{UGATEpdl}$		--	22	--		
		$t_{LGATEpdh}$		See Timing Diagram	--	20		--
		$t_{LGATEpdl}$			--	8		--
Output								
UGATE Drive Source	$I_{UGATEsr}$	$V_{BOOT} - V_{PHASE} = 12V$ $V_{UGATE} - V_{PHASE} = 12V$	--	2	--	A		
UGATE Drive Sink	$R_{UGATEsk}$	$V_{BOOT} - V_{PHASE} = 12V$	--	1.4	--	Ω		
LGATE Drive Source	$I_{LGATEsr}$	$V_{CC} = 12V$, $V_{LGATE} = 2V$	--	2.2	--	A		
LGATE Drive Sink	$R_{LGATEsk}$	$V_{CC} = 12V$	--	1.1	--	Ω		

Note 1. Stresses beyond those listed "Absolute Maximum Ratings" may cause permanent damage to the device. These are stress ratings only, and functional operation of the device at these or any other conditions beyond those indicated in the operational sections of the specifications is not implied. Exposure to absolute maximum rating conditions may affect device reliability.

Note 2. θ_{JA} is measured at $T_A = 25^\circ C$ on a high effective thermal conductivity four-layer test board per JEDEC 51-7. θ_{JC} is measured at the exposed pad of the package.

Note 3. Devices are ESD sensitive. Handling precaution is recommended.

Note 4. The device is not guaranteed to function outside its operating conditions.

Typical Operating Characteristics

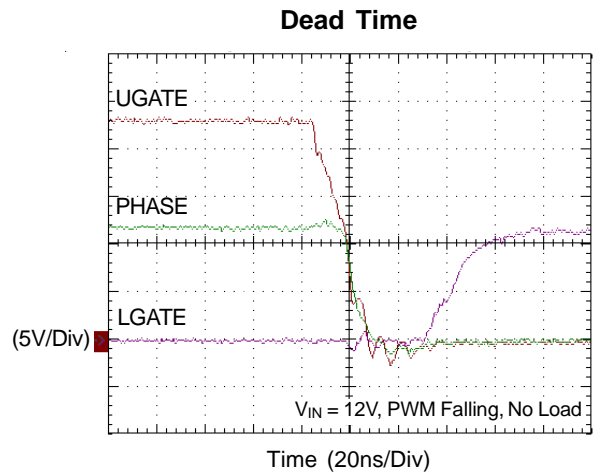
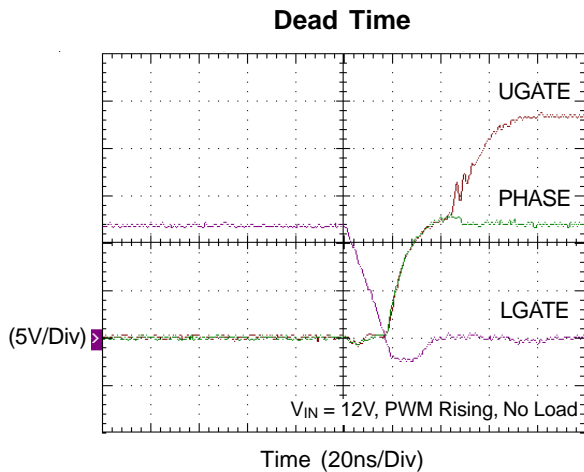
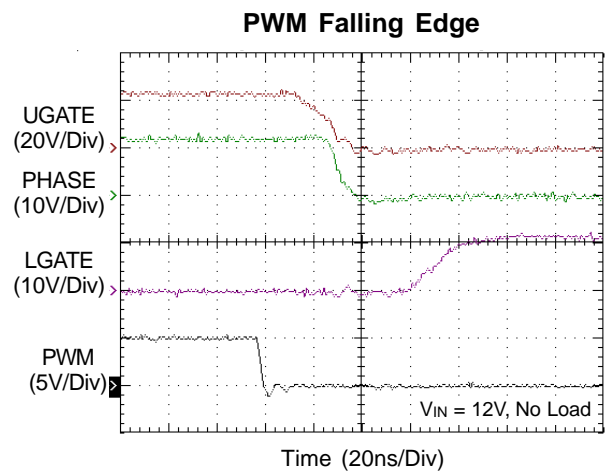
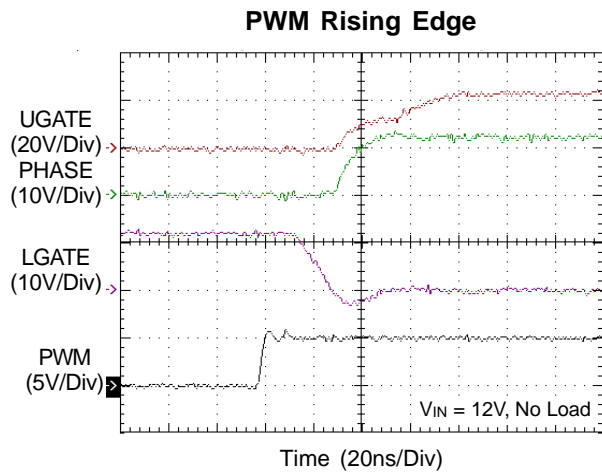
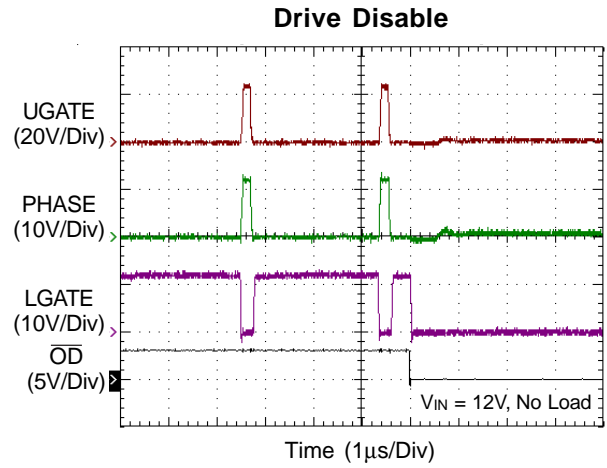
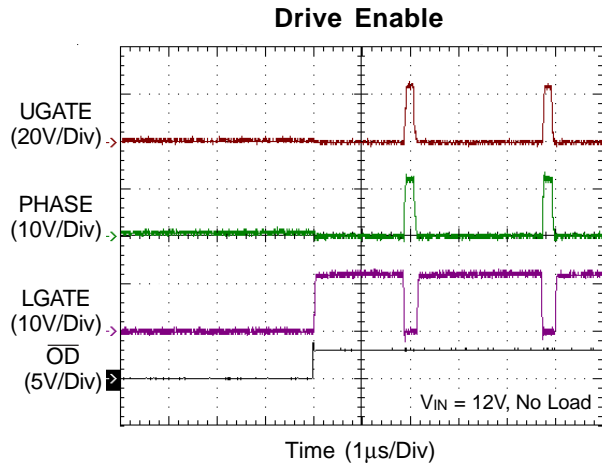

Dead Time

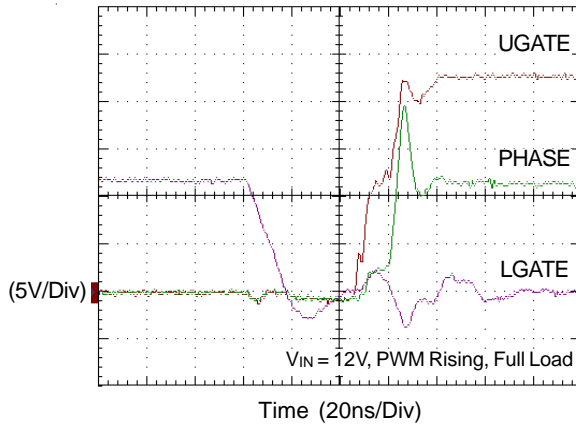

Dead Time

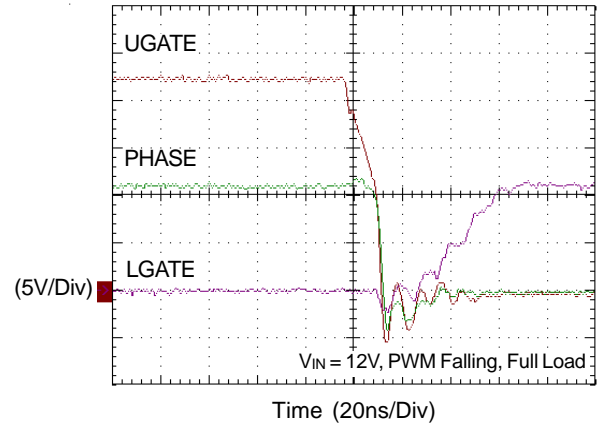

Short Pulse

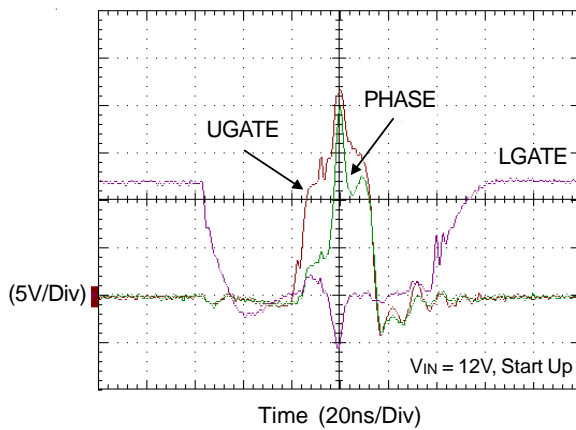

Application Information

The RT9611A/B is a High frequency, synchronous rectified, single phase dual MOSFET driver containing Richtek's advanced MOSFET driver technologies. The RT9611A/B is designed to be able to adapt from normal MOSFET driving applications to high performance CPU VR driving capabilities. The RT9611A/B can be utilized under both $V_{CC} = 5V$ or $V_{CC} = 12V$ applications which may happen in different fields of electronics application circuits. In the efficiency point of view, higher VCC equals higher driving voltage of UG/LG which may result in higher switching loss and lower conduction loss of power MOSFETs. The choice of $V_{CC} = 12V$ or $V_{CC} = 5V$ can be a tradeoff to optimize system efficiency.

The RT9611A/B are designed to drive both high side and low side N-MOSFET through external input PWM control signal. It has power on protection function which held UGATE and LGATE low before the VCC voltage rises to higher than rising threshold voltage. After the initialization, the PWM signal takes the control. The rising PWM signal first forces the LGATE signal turns low then UGATE signal is allowed to go high just after a non-overlapping time to avoid shoot through current. The falling of PWM signal first forces UGATE to go low. When UGATE and PHASE signal reach a predetermined low level, LGATE signal is allowed to turn high.

The PWM signal is acted as "High" if the signal is above the rising threshold and acted as "Low" if the signal is below the falling threshold. Any signal level enters and remains within the shutdown window is considered as "tri-state" the output drivers are disabled and both MOSFET gates are pulled and held low. If left the PWM signal floating, the pin will be kept around 1.8V by the internal divider and provide the PWM controller with a recognizable level. OD pin will also turn off both high/low side MOSFETs when tied to GND.

The RT9611A/B builds in an internal bootstrap power switch to replace external bootstrap diode, and this can facilitate PCB design and reduce total BOM cost of the system. Hence, no external bootstrap diode is required in real applications.

The difference of the RT9611A and the RT9611B is the

propagation delay, $t_{UGATEpdh}$. The RT9611B has comparatively large $t_{UGATEpdh}$ to further prevent from shoot through when high side power MOSFETs are going to be turned on. The long propagation delay of the RT9611B sacrifices efficiency for compromise of system safety. Hence, the RT9611A is usually recommended to be utilized in performance oriented applications, such as high power density CPU VR or GPU VR.

Non-overlap Control

To prevent the overlap of the gate drives during the UGATE pull low and the LGATE pull high, the non-overlap circuit monitors the voltages at the PHASE node and high side gate drive (UGATE-PHASE). When the PWM input signal goes low, UGATE begins to pull low (after propagation delay). Before LGATE can pull high, the non-overlap protection circuit ensures that the monitored voltages have gone below 1.1V. Once the monitored voltages fall below 1.1V, LGATE begins to turn high. For short pulse condition, if the PHASE pin had not gone high after LGATE pulls low, the LGATE has to wait for 200ns before pull high. By waiting for the voltages of the PHASE pin and high side gate drive to fall below 1.1V, the non-overlap protection circuit ensures that UGATE is low before LGATE pulls high.

Also to prevent the overlap of the gate drives during LGATE pull low and UGATE pull high, the non-overlap circuit monitors the LGATE voltage. When LGATE go below 1.1V, UGATE is allowed to go high.

Driving Power MOSFETS

The DC input impedance of the power MOSFET is extremely high. When V_{gs1} or V_{gs2} is at 12V or 5V, the gate draws the current only for few nano-amperes. Thus once the gate has been driven up to "ON" level, the current could be negligible.

However, the capacitance at the gate to source terminal should be considered. It requires relatively large currents to drive the gate up and down 12V (or 5V) rapidly. It is also required to switch drain current on and off with the required speed. The required gate drive currents are calculated as follows.

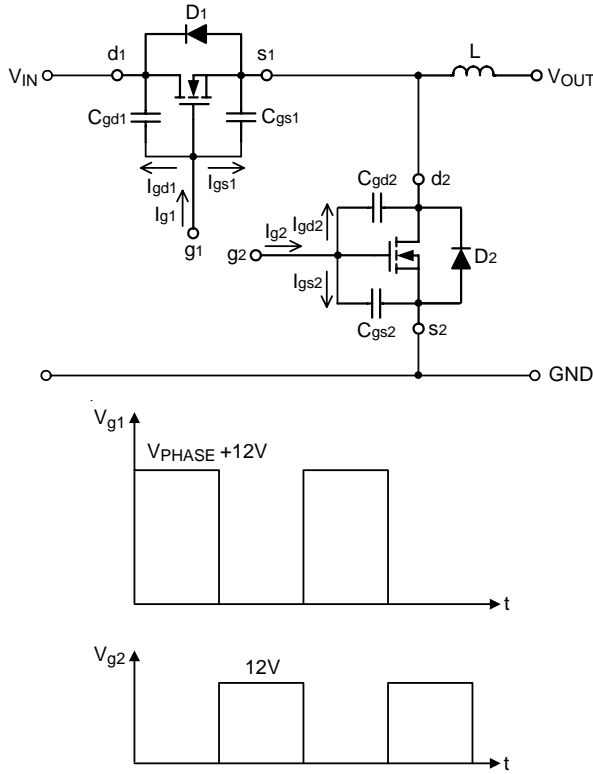

Figure1. Equivalent Circuit and Associated Waveforms

In Figure 1, the current I_{g1} and I_{g2} are required to move the gate up to 12V. The operation consists of charging C_{gd1} , C_{gd2} , C_{gs1} and C_{gs2} . C_{gs1} and C_{gs2} are the capacitors from gate to source of the high side and the low side power MOSFETs, respectively. In general data sheets, the C_{gs1} and C_{gs2} are referred as “ C_{iss} ” which are the input capacitors. C_{gd1} and C_{gd2} are the capacitors from gate to drain of the high side and the low side power MOSFETs, respectively and referred to the data sheets as “ C_{rss} ” the reverse transfer capacitance. For example, t_{r1} and t_{r2} are the rising time of the high side and the low side power MOSFETs respectively, the required current I_{gs1} and I_{gs2} , are shown as below :

$$I_{gs1} = C_{gs1} \frac{dV_{g1}}{dt} = \frac{C_{gs1} \times 12}{t_{r1}} \quad (1)$$

$$I_{gs2} = C_{gs2} \frac{dV_{g2}}{dt} = \frac{C_{gs2} \times 12}{t_{r2}} \quad (2)$$

Before driving the gate of the high side MOSFET up to 12V (or 5V), the low side MOSFET has to be off; and the high side MOSFET is turned off before the low side is

turned on. From Figure 1, the body diode “ D_2 ” had been turned on before high side MOSFETs turned on.

$$I_{gd1} = C_{gd1} \frac{dV}{dt} = C_{gd1} \frac{12}{t_{r1}} \quad (3)$$

Before the low side MOSFET is turned on, the C_{gd2} have been charged to V_{IN} . Thus, as C_{gd2} reverses its polarity and g_2 is charged up to 12V, the required current is :

$$I_{gd2} = C_{gd2} \frac{dV}{dt} = C_{gd2} \frac{V_i + 12}{t_{r2}} \quad (4)$$

It is helpful to calculate these currents in a typical case. Assume a synchronous rectified buck converter, input voltage $V_{IN} = 12V$, $V_{g1} = V_{g2} = 12V$. The high side MOSFET is PHB83N03LT whose $C_{iss} = 1660pF$, $C_{rss} = 380pF$, and $t_r = 14ns$. The low side MOSFET is PHB95N03LT whose $C_{iss} = 2200pF$, $C_{rss} = 500pF$ and $t_r = 30ns$, from the equation (1) and (2) we can obtain :

$$I_{gs1} = \frac{1660 \times 10^{-12} \times 12}{14 \times 10^{-9}} = 1.428 \quad (A) \quad (5)$$

$$I_{gs2} = \frac{2200 \times 10^{-12} \times 12}{30 \times 10^{-9}} = 0.88 \quad (A) \quad (6)$$

from equation. (3) and (4)

$$I_{gd1} = \frac{380 \times 10^{-12} \times 12}{14 \times 10^{-9}} = 0.326 \quad (A) \quad (7)$$

$$I_{gd2} = \frac{500 \times 10^{-12} \times (12+12)}{30 \times 10^{-9}} = 0.4 \quad (A) \quad (8)$$

the total current required from the gate driving source can be calculated as following equations :

$$I_{g1} = I_{gs1} + I_{gd1} = (1.428 + 0.326) = 1.754 \quad (A) \quad (9)$$

$$I_{g2} = I_{gs2} + I_{gd2} = (0.88 + 0.4) = 1.28 \quad (A) \quad (10)$$

By a similar calculation, we can also get the sink current required from the turned off MOSFET.

Select the Bootstrap Capacitor

Figure 2 shows part of the bootstrap circuit of the RT9611A/B. The V_{CB} (the voltage difference between BOOT and PHASE on RT9611A/B) provides a voltage to the gate of the high side power MOSFET. This supply needs to be ensured that the MOSFET can be driven. For this, the

capacitance C_B has to be selected properly. It is determined by following constraints.

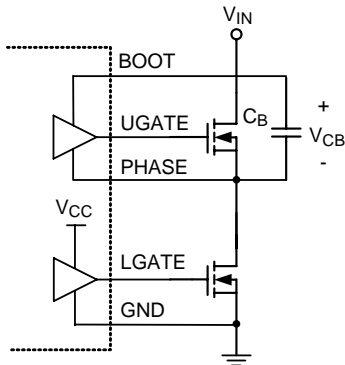

Figure 2. Part of Bootstrap Circuit of RT9611A/B

In practice, a low value capacitor C_B will lead to the over charging that could damage the IC. Therefore, to minimize the risk of overcharging and to reduce the ripple on V_{CB} , the bootstrap capacitor should not be smaller than $0.1\mu\text{F}$, and the larger the better. In general design, using $1\mu\text{F}$ can provide better performance. At least one low ESR capacitor should be used to provide good local de-coupling. It is recommended to adopt a ceramic or tantalum capacitor.

Power Dissipation

To prevent driving the IC beyond the maximum recommended operating junction temperature of 125°C , it is necessary to calculate the power dissipation appropriately. This dissipation is a function of switching frequency and total gate charge of the selected MOSFET.

Figure 3 shows the power dissipation test circuit. C_L and C_U are the UGATE and LGATE load capacitors, respectively. The bootstrap capacitor value is $1\mu\text{F}$.

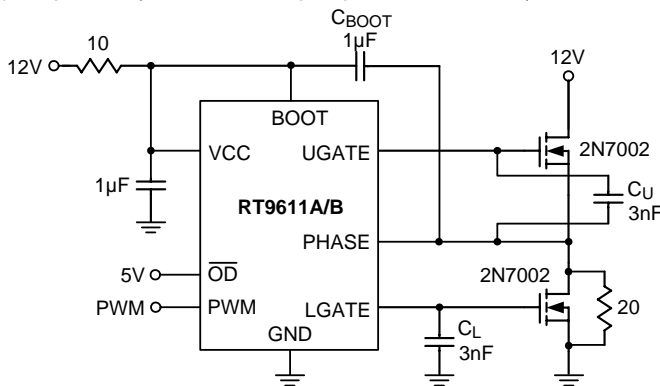

Figure 3. Test Circuit

Figure 4 shows the power dissipation of the RT9611A/B as a function of frequency and load capacitance. The value of C_U and C_L are the same and the frequency is varied from 100kHz to 1MHz.

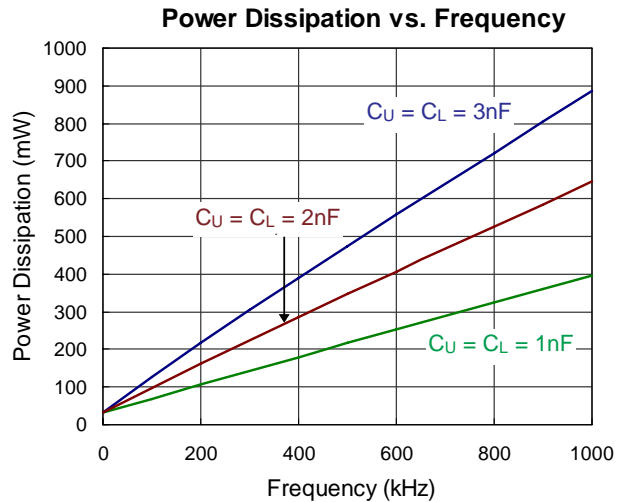

Figure 4. Power Dissipation vs. Frequency

The operating junction temperature can be calculated from the power dissipation curves (Figure 4). Assume $V_{CC} = 12\text{V}$, operating frequency is 200kHz and $C_U = C_L = 1\text{nF}$ which emulate the input capacitances of the high side and low side power MOSFETs. From Figure 4, the power dissipation is 100mW . Thus, for example, with the SOP-8 package thermal resistance θ_{JA} is $120^\circ\text{C}/\text{W}$. The operating junction temperature is calculated as :

$$T_J = (120^\circ\text{C}/\text{W} \times 100\text{mW}) + 25^\circ\text{C} = 37^\circ\text{C} \quad (11)$$

where the ambient temperature is 25°C .

Thermal Considerations

For recommended operating condition specifications of the RT9611A/B, the maximum junction temperature is 125°C and T_A is the ambient temperature. The junction to ambient thermal resistance, θ_{JA} , is layout dependent. For SOP-8 packages, the thermal resistance, θ_{JA} , is $120^\circ\text{C}/\text{W}$ on a standard JEDEC 51-7 four-layer thermal test board. For SOP-8 (Exposed Pad) packages, the thermal resistance, θ_{JA} , is $75^\circ\text{C}/\text{W}$ on a standard JEDEC 51-7 four-layer thermal test board. For WDFN-8EL 3x3 packages, the thermal resistance, θ_{JA} , is $70^\circ\text{C}/\text{W}$ on a standard JEDEC 51-7 four-layer thermal test board. The

maximum power dissipation at $T_A = 25^\circ\text{C}$ can be calculated by the following formulas :

$$P_{D(\text{MAX})} = (125^\circ\text{C} - 25^\circ\text{C}) / (120^\circ\text{C}/\text{W}) = 0.833\text{W for SOP-8 package}$$

$$P_{D(\text{MAX})} = (125^\circ\text{C} - 25^\circ\text{C}) / (75^\circ\text{C}/\text{W}) = 1.333\text{W for SOP-8 (Exposed Pad) package}$$

$$P_{D(\text{MAX})} = (125^\circ\text{C} - 25^\circ\text{C}) / (70^\circ\text{C}/\text{W}) = 1.429\text{W for WDFN-8EL 3x3 package}$$

The maximum power dissipation depends on the operating ambient temperature for fixed $T_{J(\text{MAX})}$ and thermal resistance, θ_{JA} . The derating curves in Figure 5 allow the designer to see the effect of rising ambient temperature on the maximum power dissipation.

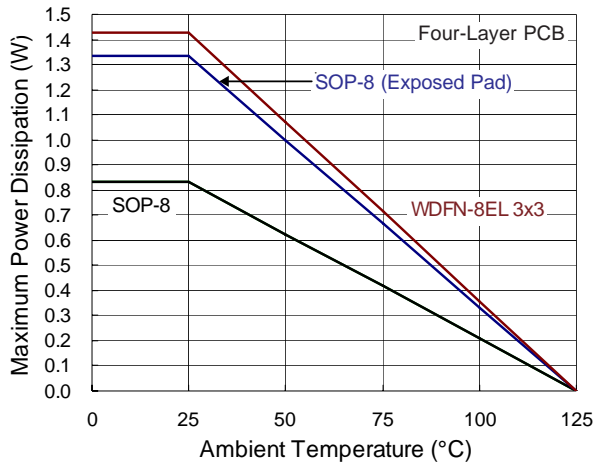

Figure 5. Derating Curve of Maximum Power Dissipation

Layout Consideration

Figure 6 shows the schematic circuit of a synchronous buck converter to implement the RT9611A/B. The converter operates from 5V to 12V of input Voltage.

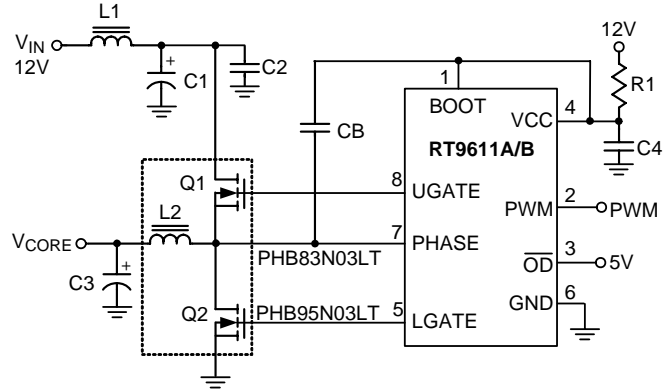
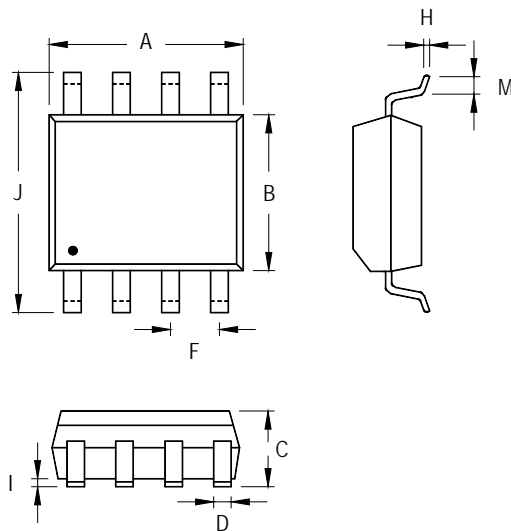

Figure 6. Synchronous Buck Converter Circuit

When layout the PCB, it should be very careful. The power circuit section is the most critical one. If not configured properly, it will generate a large amount of EMI. The junction of Q1, Q2, L2 should be very close.

Next, the trace from UGATE, and LGATE should also be short to decrease the noise of the driver output signals. PHASE signals from the junction of the power MOSFET, carrying the large gate drive current pulses, should be as heavy as the gate drive trace. The bypass capacitor C4 should be connected to GND directly. Furthermore, the bootstrap capacitors (C_B) should always be placed as close to the pins of the IC as possible.

Outline Dimension



Symbol	Dimensions In Millimeters		Dimensions In Inches	
	Min	Max	Min	Max
A	4.801	5.004	0.189	0.197
B	3.810	3.988	0.150	0.157
C	1.346	1.753	0.053	0.069
D	0.330	0.508	0.013	0.020
F	1.194	1.346	0.047	0.053
H	0.170	0.254	0.007	0.010
I	0.050	0.254	0.002	0.010
J	5.791	6.200	0.228	0.244
M	0.400	1.270	0.016	0.050

8-Lead SOP Plastic Package

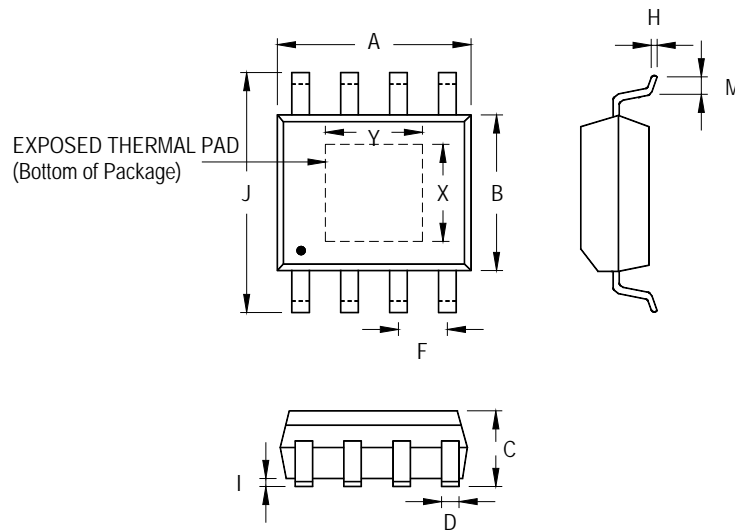

Symbol	Dimensions In Millimeters		Dimensions In Inches		
	Min	Max	Min	Max	
A	4.801	5.004	0.189	0.197	
B	3.810	4.000	0.150	0.157	
C	1.346	1.753	0.053	0.069	
D	0.330	0.510	0.013	0.020	
F	1.194	1.346	0.047	0.053	
H	0.170	0.254	0.007	0.010	
I	0.000	0.152	0.000	0.006	
J	5.791	6.200	0.228	0.244	
M	0.406	1.270	0.016	0.050	
Option 1	X	2.000	2.300	0.079	0.091
	Y	2.000	2.300	0.079	0.091
Option 2	X	2.100	2.500	0.083	0.098
	Y	3.000	3.500	0.118	0.138

8-Lead SOP (Exposed Pad) Plastic Package

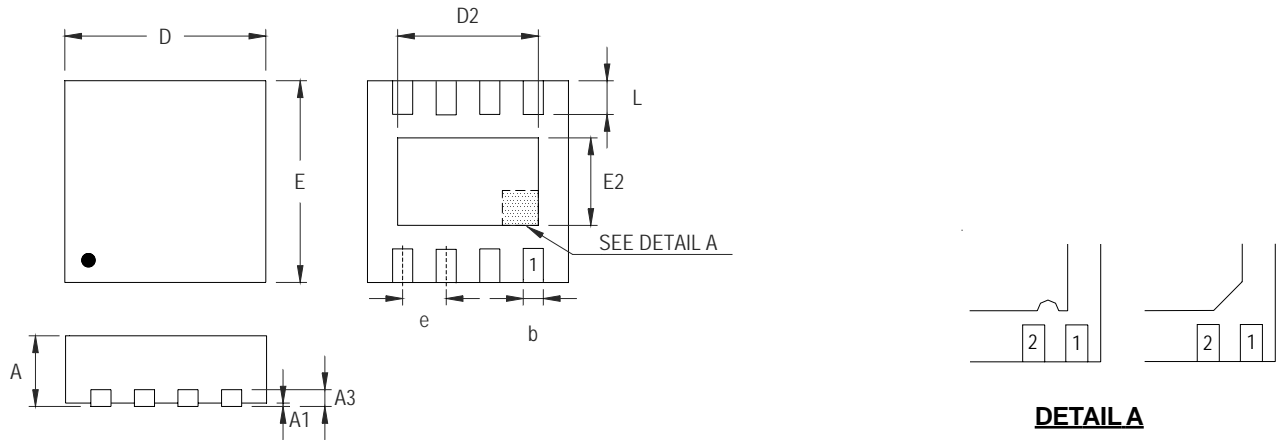

DETAIL A
Pin #1 ID and Tie Bar Mark Options

Note : The configuration of the Pin #1 identifier is optional, but must be located within the zone indicated.

Symbol	Dimensions In Millimeters		Dimensions In Inches	
	Min	Max	Min	Max
A	0.700	0.800	0.028	0.031
A1	0.000	0.050	0.000	0.002
A3	0.175	0.250	0.007	0.010
b	0.180	0.300	0.007	0.012
D	2.950	3.050	0.116	0.120
D2	2.200	2.700	0.087	0.106
E	2.950	3.050	0.116	0.120
E2	1.450	1.750	0.057	0.069
e	0.500		0.020	
L	0.350	0.450	0.014	0.018

W-Type 8EL DFN 3x3 Package (0.5mm Lead Pitch)

Richtek Technology Corporation

5F, No. 20, Taiyuen Street, Chupei City
Hsinchu, Taiwan, R.O.C.
Tel: (8863)5526789

Richtek products are sold by description only. Richtek reserves the right to change the circuitry and/or specifications without notice at any time. Customers should obtain the latest relevant information and data sheets before placing orders and should verify that such information is current and complete. Richtek cannot assume responsibility for use of any circuitry other than circuitry entirely embodied in a Richtek product. Information furnished by Richtek is believed to be accurate and reliable. However, no responsibility is assumed by Richtek or its subsidiaries for its use; nor for any infringements of patents or other rights of third parties which may result from its use. No license is granted by implication or otherwise under any patent or patent rights of Richtek or its subsidiaries.