

## Micro-Power Voltage Detectors with Manual Reset

### General Description

The RT9816 is a micro-power voltage detector with deglitched manual reset input supervising the power supply voltage level for microprocessors ( $\mu$ P) or digital systems. It provides internally fixed threshold levels with 0.1V per step ranging from 1.0V to 5V, which covers most digital applications. It features low supply current of  $3\mu$ A. The RT9816 performs supervisory function by sending out a reset signal whenever the  $V_{DD}$  voltage falls below a preset threshold level. This reset signal will last the whole period before  $V_{DD}$  recovering. Once  $V_{DD}$  recovered upcrossing the threshold level, the reset signal will be released after a certain delay time. To pull reset signal low manually, just pull the manual reset input (MR) below the specified  $V_{IL}$  level. RT9816 is provided in SC-82 package.

### Ordering Information

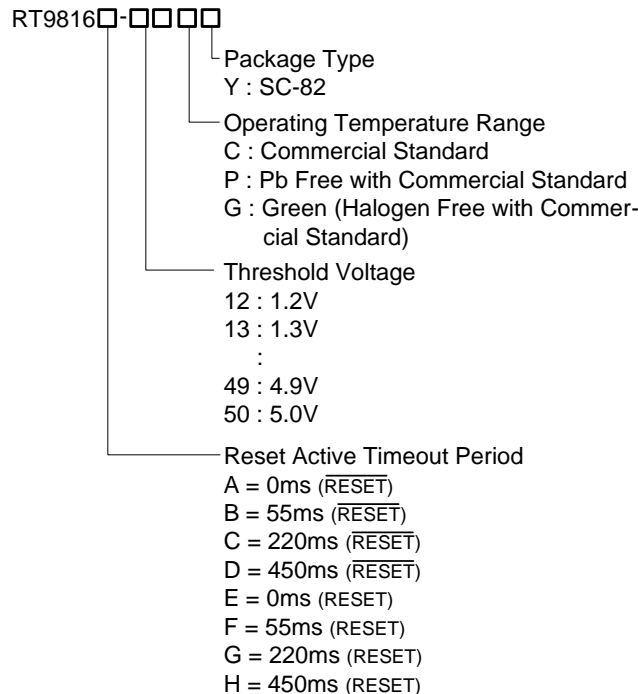

Note :

RichTek Pb-free and Green products are :

- ▶RoHS compliant and compatible with the current requirements of IPC/JEDEC J-STD-020.
- ▶Suitable for use in SnPb or Pb-free soldering processes.
- ▶100%matte tin (Sn) plating.

### Features

- Internally Fixed Threshold 1.0V to 5V in 0.1V Step
- High Accuracy  $\pm 1.5\%$
- Low Supply Current  $3\mu$ A
- No External Components Required
- Quick Reset within 20 $\mu$ s
- Built-in Recovery Delay Include 0ms, 55ms, 220ms, 450ms Options
- 800ns Glitch Immunity of Manual Reset Input
- Low Functional Supply Voltage 0.9V
- N-Channel Open-Drain Output,
- Small SC-82 Package
- RoHS Compliant and 100% Lead (Pb)-Free

### Applications

- Computers
- Controllers
- Intelligent Instruments
- Critical  $\mu$ P and  $\mu$ C Power Monitoring
- Portable/Battery-Powered Equipment

### Marking Information

For marking information, contact our sales representative directly or through a RichTek distributor located in your area, otherwise visit our website for detail.

### Pin Configurations

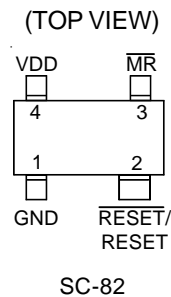

**Note :** There is no pin1 indicator on top mark for SC-82 type, and pin 1 will be lower left pin when reading top mark from left to right. Pin2 of SC-82 is wider than other pins.

## Typical Application Circuit

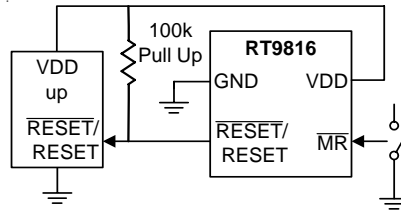

## Functional Pin Description

Pin Name	Pin Function
GND	Ground Pin
$\overline{\text{RESET}}$	Active Low Open-Drain Reset Output
RESET	Active High Open-Drain Reset Output
MR	Manual Reset
VDD	Power Pin

## Function Block Diagram

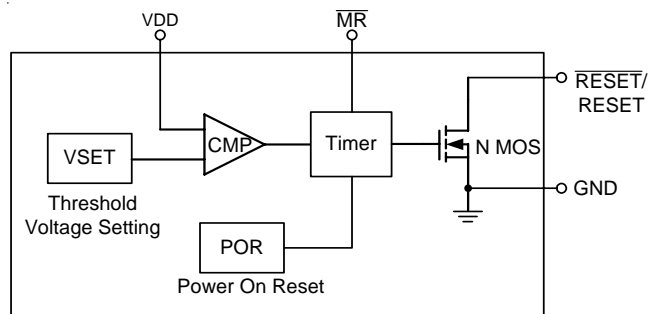

**Absolute Maximum Ratings** (Note 1)

- Terminal Voltage (with Respect to GND)  
 $V_{DD}$  ----- -0.3V to 6.0V
- All Other Inputs ----- -0.3V to  $V_{DD}+0.3V$
- Input Current,  $I_{VDD}$  ----- 20mA
- Power Dissipation, PD @  $T_A = 25^\circ C$   
 SC-82 ----- 0.25W
- Package Thermal Resistance (Note 4)  
 SC-82,  $\theta_{JA}$  ----- 400 $^\circ C$
- Lead Temperature (Soldering, 10sec.)----- 260 $^\circ C$
- Storage Temperature Range ----- -65 $^\circ C$  to 125 $^\circ C$
- ESD Susceptibility (Note 2)  
 HBM (Human Body Mode) ----- 2kV  
 MM (Machine Mode) ----- 200V

**Recommended Operating Conditions** (Note 3)

- Junction Temperature Range ----- -40 $^\circ C$  to 125 $^\circ C$
- Ambient Temperature Range ----- -40 $^\circ C$  to 85 $^\circ C$

**Electrical Characteristics**

( $V_{DD} = 3V$ , unless otherwise specified)

Parameter	Symbol	Test Conditions	Min	Typ	Max	Units
Operating $V_{DD}$ ( $V_{OUT}$ ) Range	$V_{DD}$		0.9	--	6	V
Supply Current	$I_{DD}$	$V_{TH} = 3V, V_{DD} = 4.5V, T_A = 27^\circ C$	--	3	8	$\mu A$
Reset Threshold	$V_{TH}$	$T_A = 27^\circ C$	--	1.2 to 5.0	--	V
MR Input Threshold	$V_{IL}$	$T_A = 27^\circ C, V_{TH} > 1.2V$	--	--	0.25 $V_{DD}$	V
	$V_{IH}$	$T_A = 27^\circ C, V_{TH} > 1.2V$	0.7 $V_{DD}$	--	--	
MR Glitch Rejection			--	800	--	ns
Threshold Voltage Accuracy	$\Delta V_{TH}$	$T_A = 27^\circ C$	-1.5	--	+1.5	%
$V_{DD}$ Drop to Reset Delay	$t_{RD}$	Drop = $V_{TH} - 125mV$	--	20	--	$\mu s$
Reset Active Time Out Period	RT9816A/E	$V_{DD} \geq 1.02 \times V_{TH}$	--	0	--	ms
	RT9816B/F		35	55	75	ms
	RT9816C/G		143	220	297	ms
	RT9816D/H		292	450	608	ms
RESET Output Voltage Low	$V_{OL}$	$3 = V_{DD} < V_{TH}, I_{SINK} > 3.5mA$	--	--	0.4	V
Hysteresis Width	$V_{HYS}$		--	0.01 $V_{TH}$	--	V

**Note 1.** Stresses listed as the above "Absolute Maximum Ratings" may cause permanent damage to the device. These are for stress ratings. Functional operation of the device at these or any other conditions beyond those indicated in the operational sections of the specifications is not implied. Exposure to absolute maximum rating conditions for extended periods may remain possibility to affect device reliability.

**Note 2.** Devices are ESD sensitive. Handling precaution recommended.

**Note 3.** The device is not guaranteed to function outside its operating conditions.

**Note 4.**  $\theta_{JA}$  is measured in the natural convection at  $T_A = 25^\circ\text{C}$  on a low effective thermal conductivity test board of JEDEC 51-3 thermal measurement standard.

**Typical Operating Characteristics**

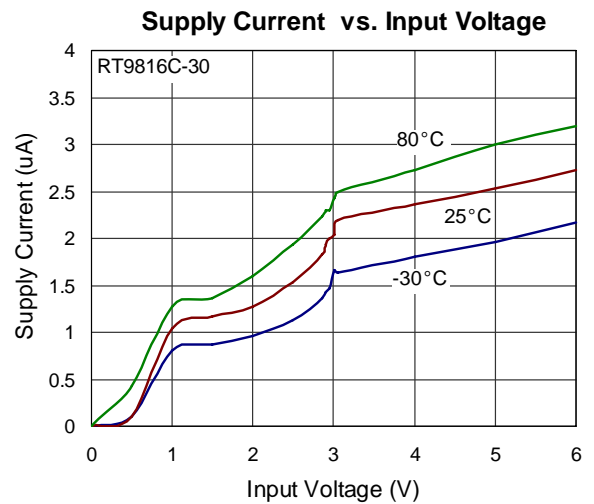
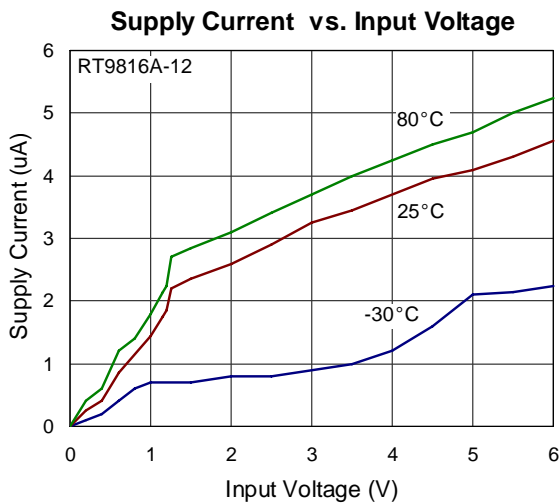
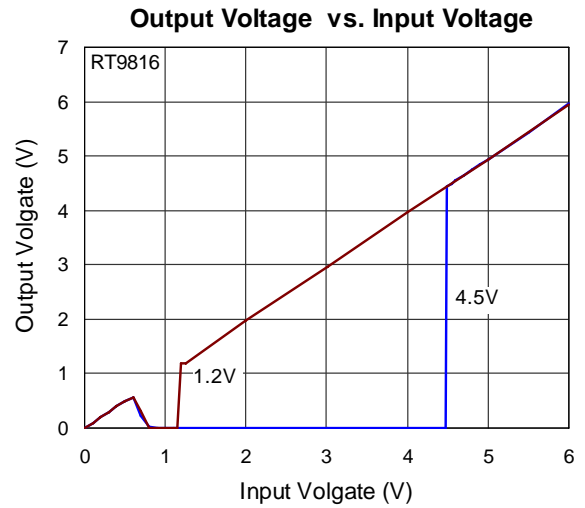
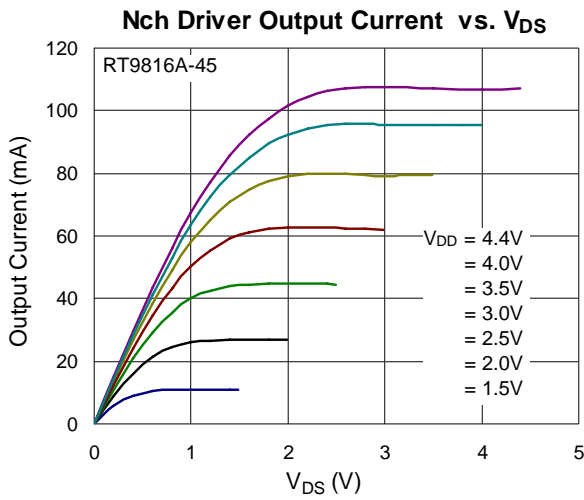
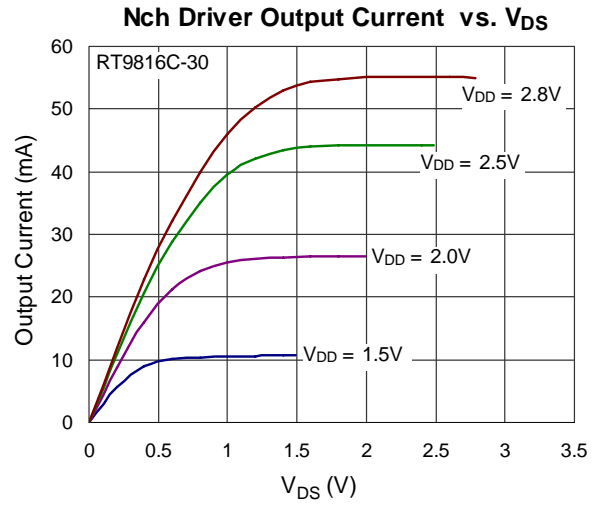
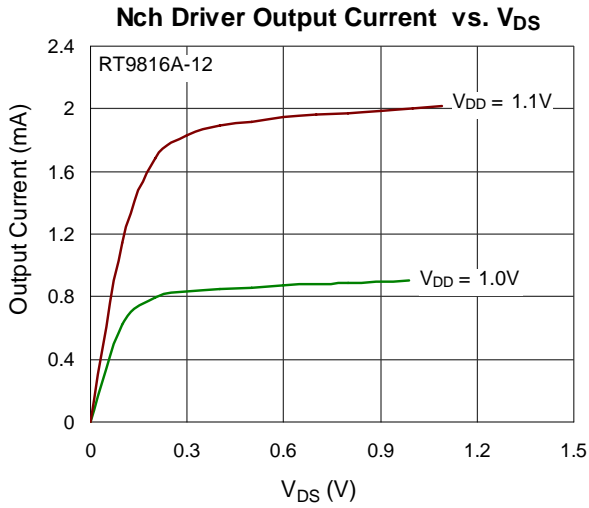

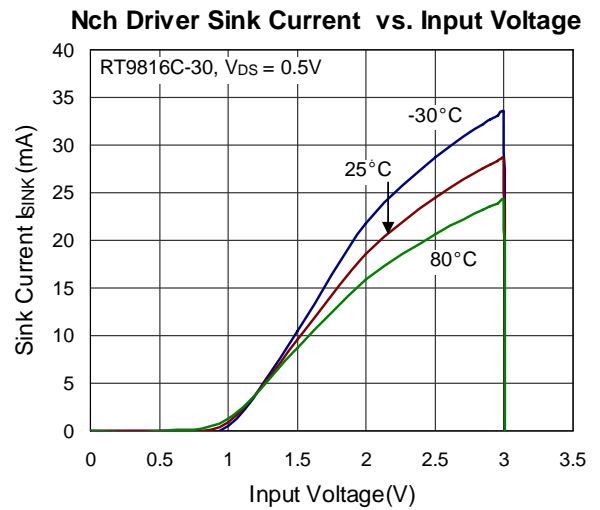
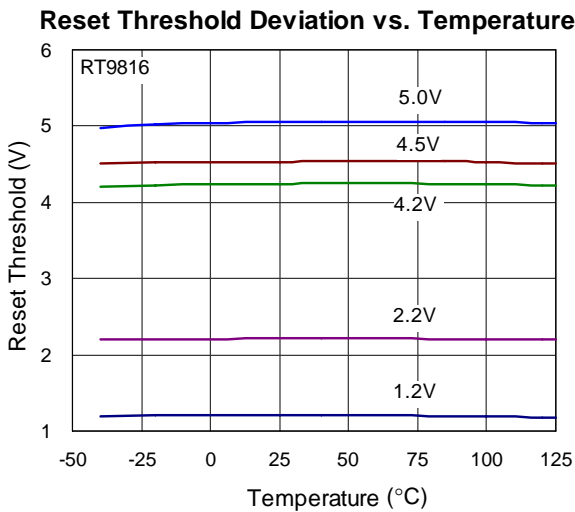
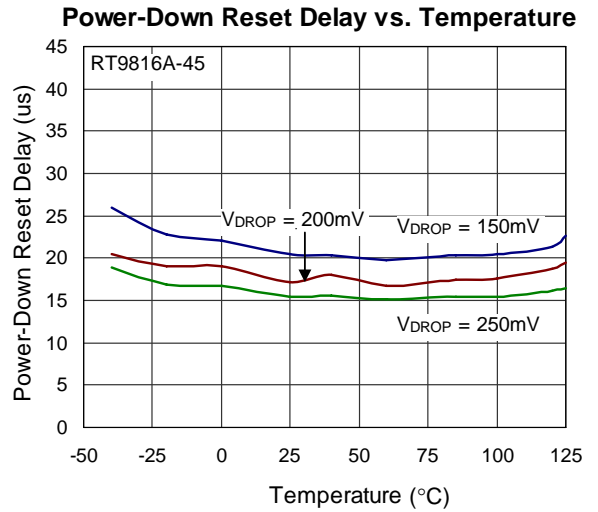
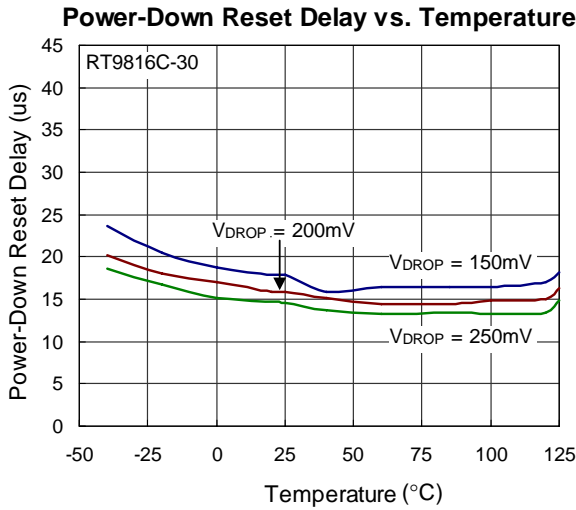
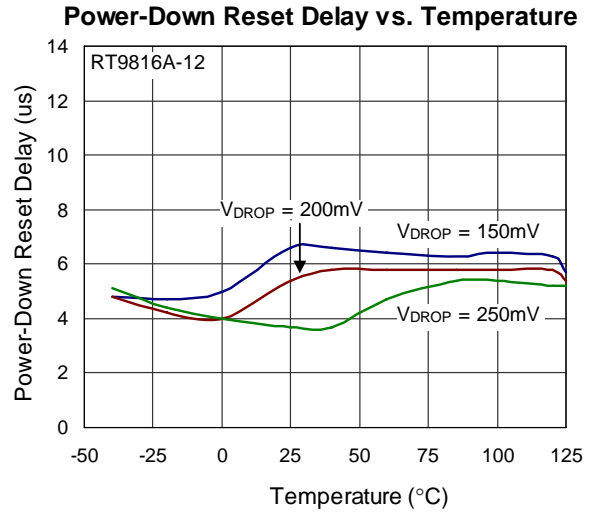
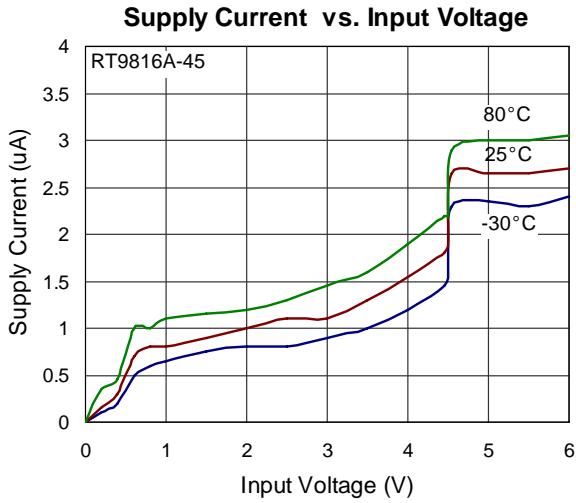

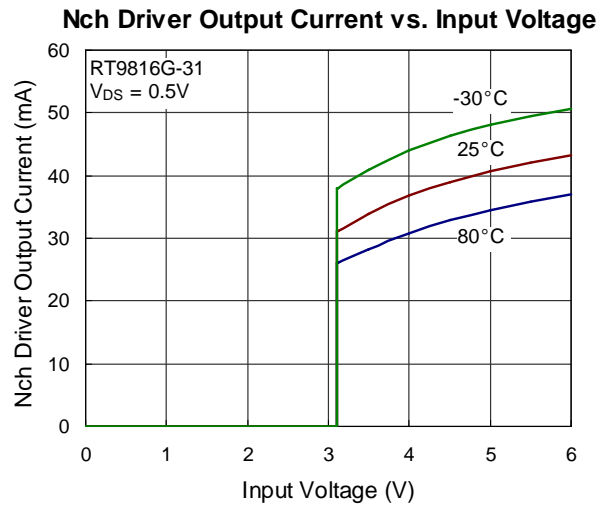
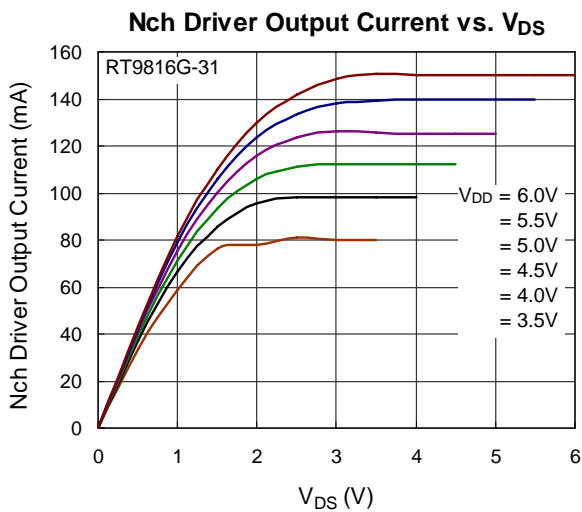
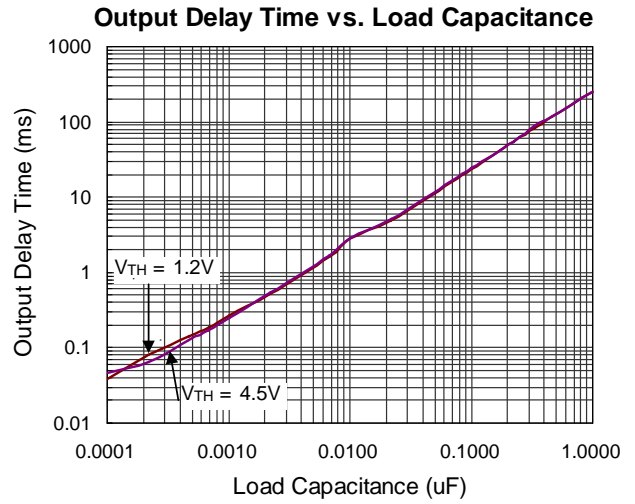
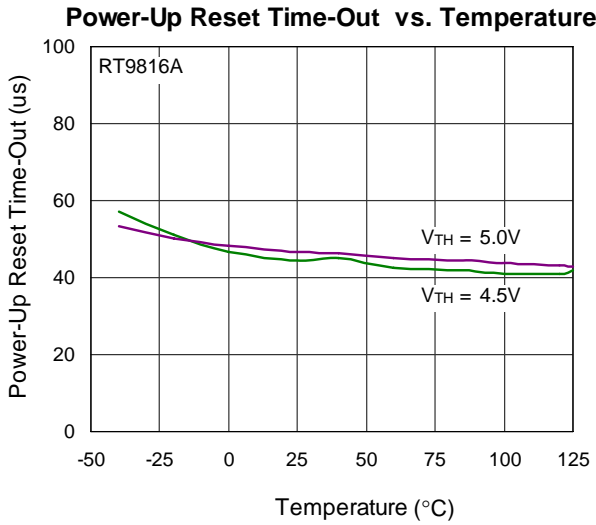
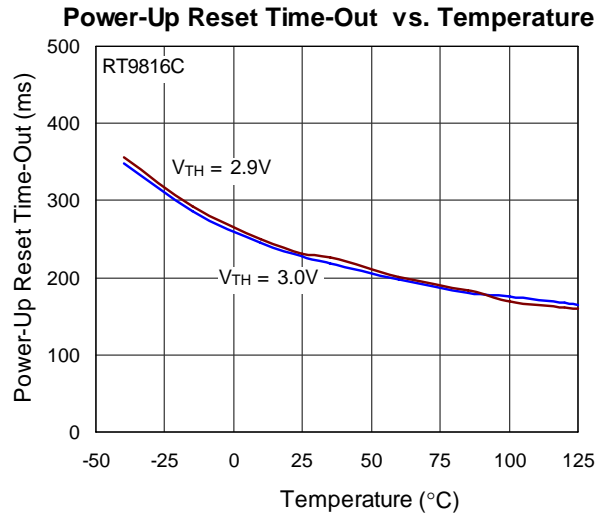
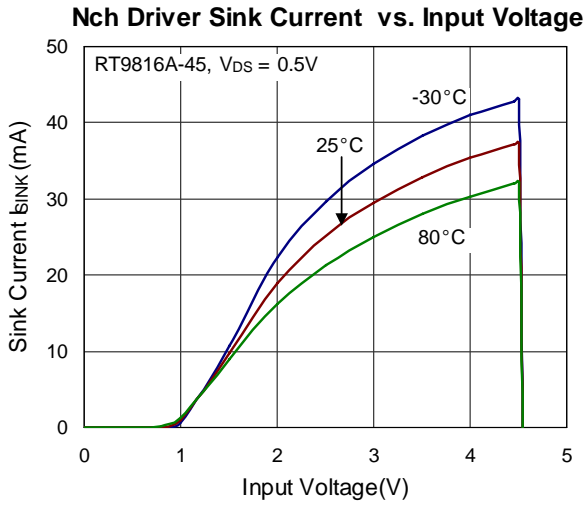

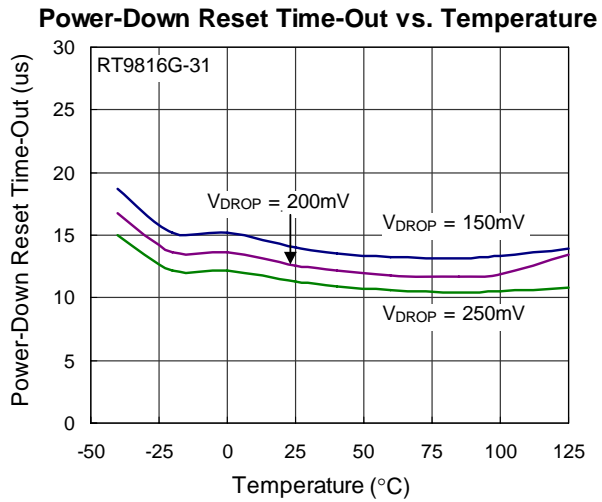
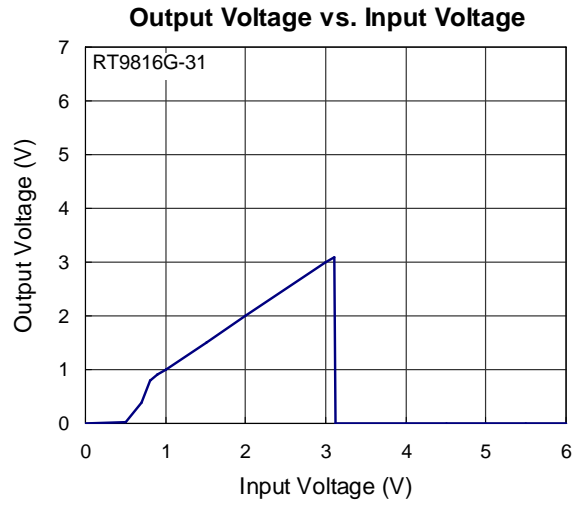
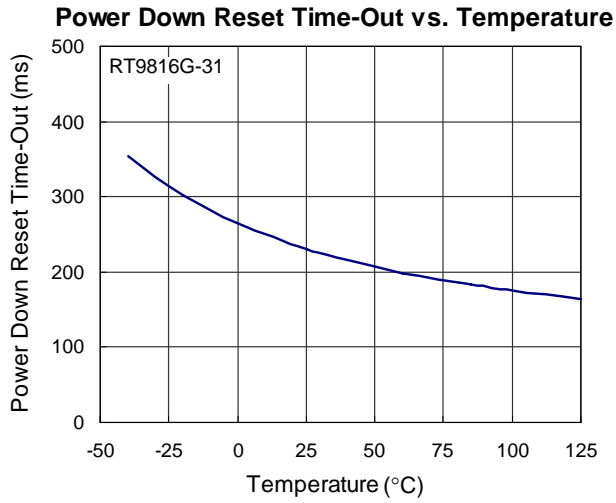



---

## Application Information

### Multiple Supplies

Mainly, the pull-up connected to the RT9816 will connect to the supply voltage that is being monitored at the IC's VCC pin. However, some systems may use the open-drain output to level-shift from the monitored supply to reset circuitry powered by some other supply.

### Benefits of Highly Accurate Reset Threshold

Most  $\mu$ P supervisor ICs have reset threshold voltages between 1% and 1.5% below the value of nominal supply voltages. This ensures a reset will not occur within 1% of the nominal supply, but will occur when the supply is 1.5% below nominal.

Outline Dimension

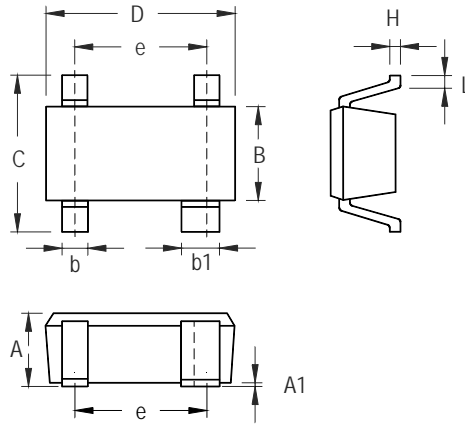

Symbol	Dimensions In Millimeters		Dimensions In Inches	
	Min	Max	Min	Max
A	0.800	1.100	0.031	0.043
A1	0.000	0.100	0.000	0.004
B	1.150	1.350	0.045	0.053
b	0.150	0.400	0.006	0.016
b1	0.350	0.500	0.014	0.020
C	1.800	2.450	0.071	0.096
D	1.800	2.200	0.071	0.087
e	1.300		0.051	
H	0.080	0.260	0.003	0.010
L	0.200	0.460	0.008	0.018

SC-82 Surface Mount Package

**Richtek Technology Corporation**

Headquarter  
 5F, No. 20, Taiyuen Street, Chupei City  
 Hsinchu, Taiwan, R.O.C.  
 Tel: (8863)5526789 Fax: (8863)5526611

**Richtek Technology Corporation**

Taipei Office (Marketing)  
 8F, No. 137, Lane 235, Paochiao Road, Hsintien City  
 Taipei County, Taiwan, R.O.C.  
 Tel: (8862)89191466 Fax: (8862)89191465  
 Email: marketing@richtek.com