

6 Channel DC/DC Converters

General Description

The RT9911 is a complete power-supply solution for digital still cameras and other hand-held devices. It integrates one selectable Boost/Buck DC-DC converter, one high-efficiency step-down DC-DC converter, one high-efficiency main step-up converter, one PWM converter for CCD positive voltage, one inverter for CCD negative voltage and one white LED driver for LCD backlight. The RT9911 is targeted for applications that use either two or three primary cells or a single lithium-ion battery.

RT9911 is available in VQFN-40L 6x6. Each DC-DC converter has independent shutdown input.

Ordering Information

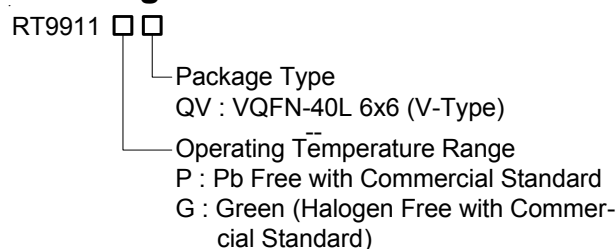

Note :

Richtek Pb-free and Green products are :

- ▶RoHS compliant and compatible with the current requirements of IPC/JEDEC J-STD-020.
- ▶Suitable for use in SnPb or Pb-free soldering processes.
- ▶100% matte tin (Sn) plating.

Applications

- Digital Still Camera
- PDA
- Portable Device

Features

- **1.6V to 5.5V Battery Input Voltage Range**
- **Synchronous Boost/Buck Selectable DC-DC Converter**
 - ▶Internal Switches
 - ▶Up to 95% Efficiency
- **Syn-Buck DC-DC Converters**
 - ▶0.8V to 5.5V Adjustable Output Voltage
 - ▶Up to 95% Efficiency
 - ▶100%_(MAX) Duty Cycle
 - ▶Internal Switches
- **Main Boost DC-DC Converter**
 - ▶Adjustable Output Voltage
 - ▶Up to 97% Efficiency
- **PWM Converter for CCD Positive Voltage**
- **Inverter for CCD Negative Voltage**
- **White LED Driver for LCD Panel Backlight**
- **Up to 1.4MHz Adjustable Switching Frequency**
- **1µA Supply Current in Shutdown Mode**
- **External Compensation Network for all Converters**
- **Independent Enable Pin to Shutdown Each Channel.**
- **40-Lead VQFN Package**
- **RoHS Compliant and 100% Lead (Pb)-Free**

Pin Configurations

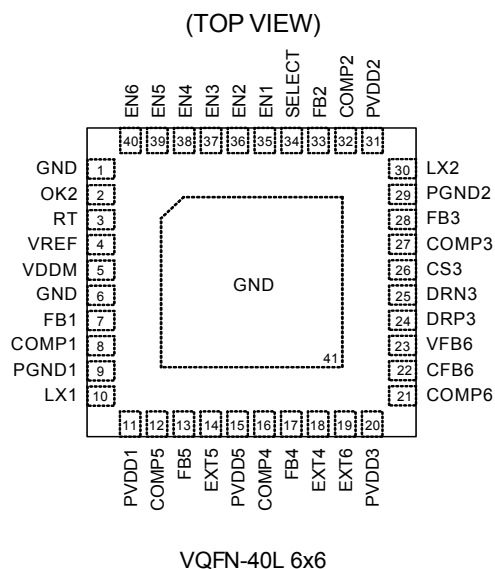

Typical Application Circuit

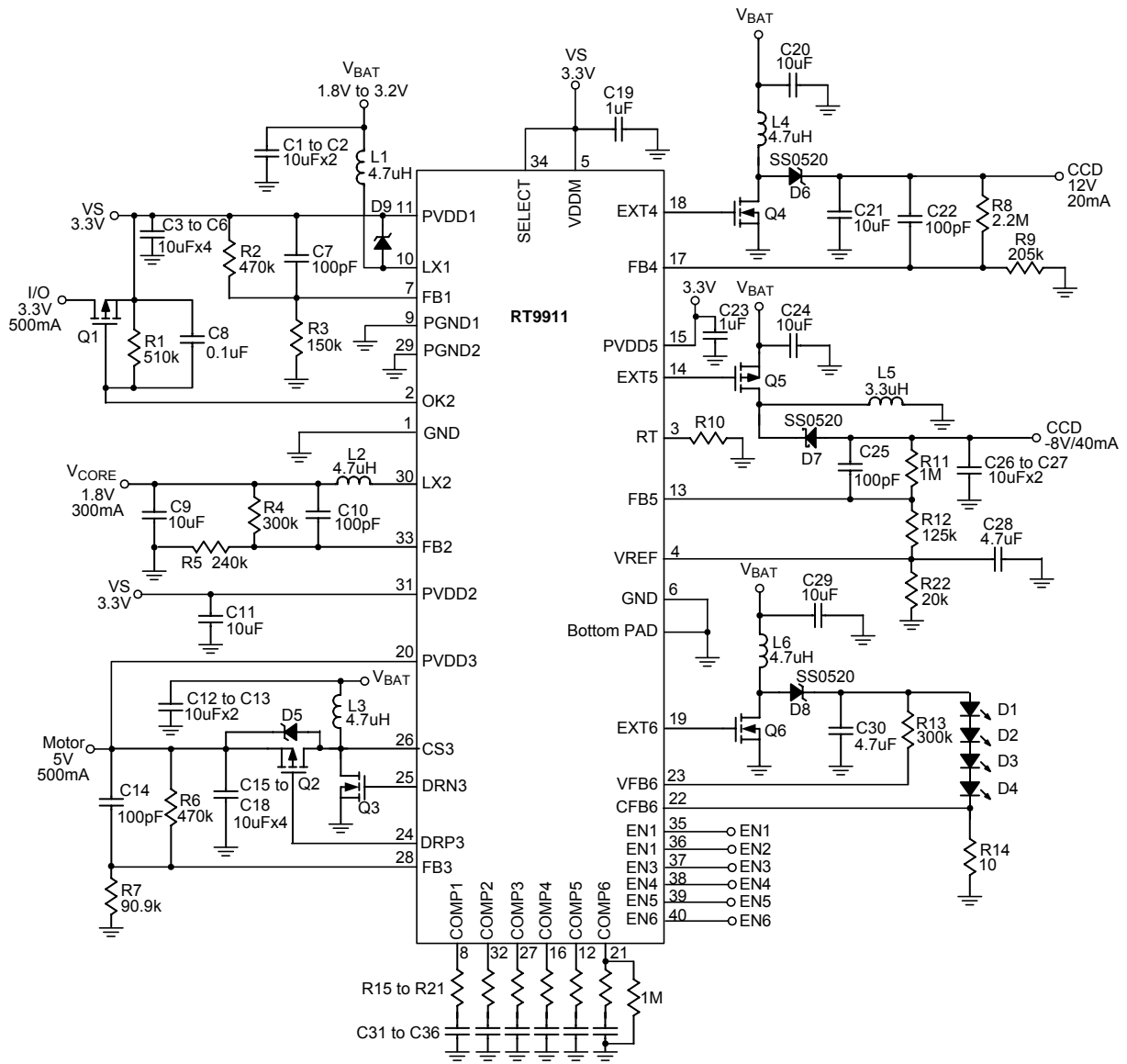

Figure 1. Application Circuit for 2-Cells Battery Supply

Note :

- Bottom pad is GND pad, can be short to pin 6 (GND).
- Please remove Q2 when use Async Boost and remove D5 when use Sync Boost.

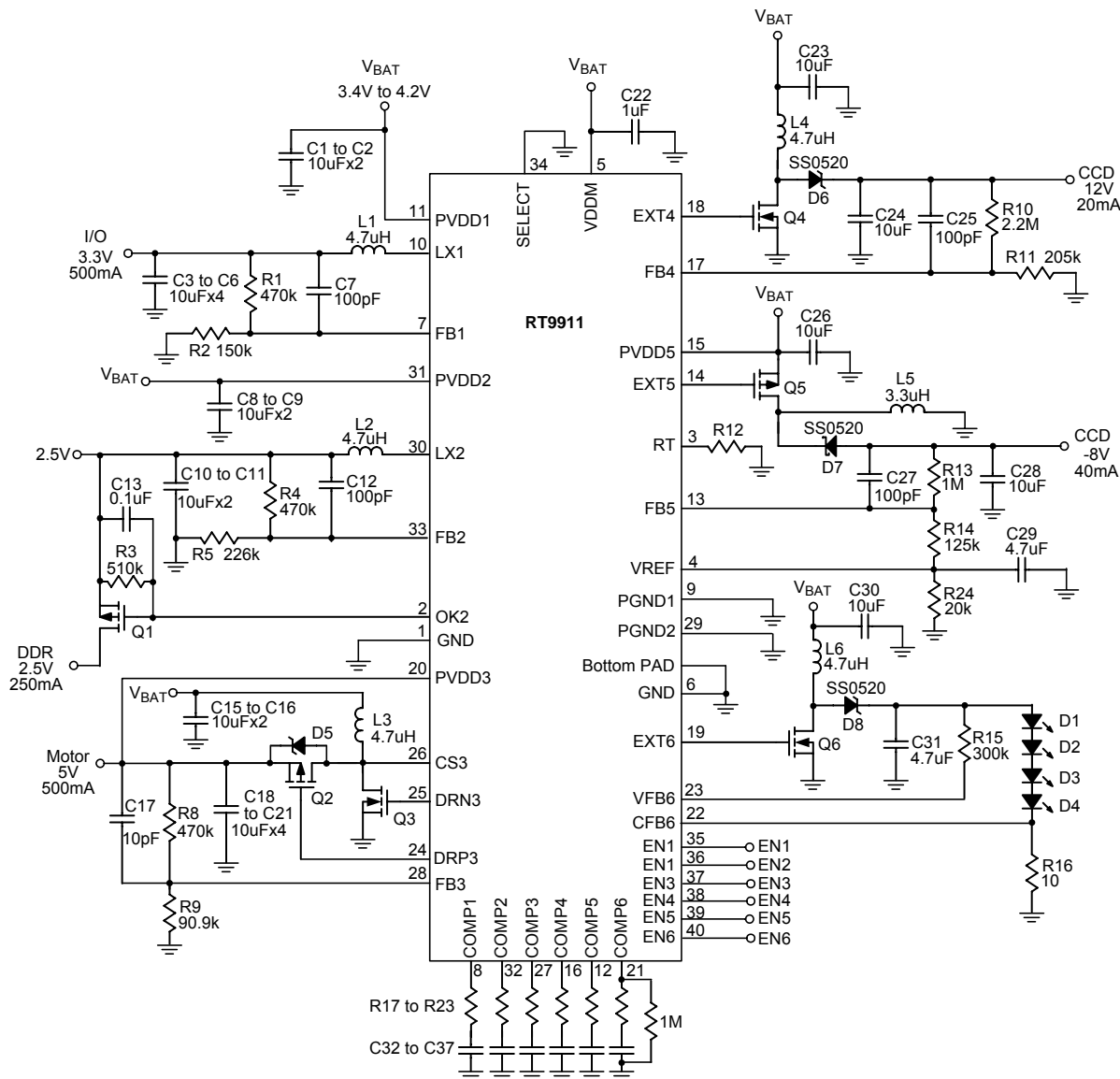

Figure 2. Application Circuit for Li-ion Battery Supply

Note :

- Bottom pad is GND pad, can be short to pin 6 (GND).
- Please remove Q2 when use Async Boost and remove D5 when use Sync Boost.
- Output voltage setting

CH1: $0.8V_x(1+R1/R2)$ ex: I/O 3.3V = $0.8x(1+470k/150k)$
 CH2: $0.8V_x(1+R4/R5)$ ex: DDR 2.5V = $0.8x(1+470k/226k)$
 CH3: $0.8V_x(1+R8/R9)$ ex: MOTOR 5V = $0.8x(1+470k/90.9k)$
 CH4: $1.0V_x(1+R10/R11)$ ex: CCD 12V = $1.0x(1+2.2M/205k)$
 CH5: $-1.0V_x(R13/R14)$ ex: CCD -8V = $-1.0x(1M/125k)$

Functional Pin Description

Pin No.	Pin Name	Pin Function	I/O	Internal State at Shut Down	I/O Configuration
1	GND	Analog Ground Pin	--	–	
2	OK2	External Switch Control.	OUT	High Impedance	
3	RT	Frequency Setting Pin. Frequency is 500kHz if RT pin not connected.	OUT	Pull Low	
5	VDDM	Device Input Power Pin	IN	–	
6	GND	Analog Ground Pin	--	–	
4	VREF	1.0V Reference Pin	OUT	High Impedance	
7	FB1	Feedback Input Pin of CH1.	IN	High Impedance	
8	COMP1	Feedback Compensation Pin of CH1.	OUT	Pull Low	
9	PGND1	Power Ground Pin of CH1.	--	–	
10	LX1	Switch Node of CH1.	OUT	High Impedance	
11	PVDD1	Power Input Pin of CH1.	IN	–	
12	COMP5	Feedback Compensation Pin of CH5.	OUT	Pull Low	
13	FB5	Feedback Input Pin of CH5.	IN	High Impedance	
14	EXT5	External Power Switch of CH5.	OUT	Pull High	
15	PVDD5	Power Input Pin of CH4, CH5 and CH6.	IN	–	
16	COMP4	Feedback Compensation Pin of CH4.	OUT	Pull Low	
17	FB4	Feedback Input Pin of CH4.	IN	High Impedance	

To be continued

Pin No.	Pin Name	Pin Function	I/O	Internal State at Shut Down	I/O Configuration
18	EXT4	External Power Switch of CH4.	OUT	Pull Low	
19	EXT6	External Power Switch of CH6.	OUT	Pull Low	
20	PVDD3	Power Input Pin of CH3.	IN	--	
24	DRP3	External PMOS Switch Pin for CH3.	OUT	Pull High	
21	COMP6	Feedback Compensation Pin of CH6.	OUT	Pull Low	
22	CFB6	Current Feedback Input Pin for CH6.	IN	High Impedance	
23	VFB6	Voltage Feedback Input Pin for CH6.	IN	High Impedance	
25	DRN3	External NMOS Switch Pin for CH3.	OUT	Pull Low	
26	CS3	Current Sense Input Pin for CH3	IN	High Impedance	

To be continued

Pin No.	Pin Name	Pin Function	I/O	Internal State at Shut Down	I/O Configuration
27	COMP3	Feedback Compensation Pin of CH3	OUT	Pull Low	
28	FB3	Feedback Input Pin of CH3.	IN	High Impedance	
29	PGND2	Power Ground Pin of CH2	--	--	
30	LX2	Switch Node of CH2	OUT	High Impedance	
31	PVDD2	Power Input Pin of CH2.	IN	--	
32	COMP2	Feedback Compensation Pin of CH2.	OUT	Pull Low	
33	FB2	Feedback Input Pin of CH2.	IN	High Impedance	
34	SELECT	CH1 Boost/Buck Selection Pin. Logic state can't be changed during operation.	IN	Pull Low	
35	EN1	Enable Input Pin of CH1.	IN	Pull Low	
36	EN2	Enable Input Pin of CH2.	IN	Pull Low	

To be continued

Pin No.	Pin Name	Pin Function	I/O	Internal State at Shut Down	I/O Configuration
37	EN3	Enable Input Pin of CH3.	IN	Pull Low	
38	EN4	Enable Input Pin of CH4.	IN	Pull Low	
39	EN5	Enable Input Pin of CH5.	IN	Pull Low	
40	EN6	Enable Input Pin of CH6.	IN	Pull Low	
Exposed Pad (41)	GND	The exposed pad must be soldered to a large PCB and connected to GND for maximum power dissipation.	--	--	--

Function Block Diagram

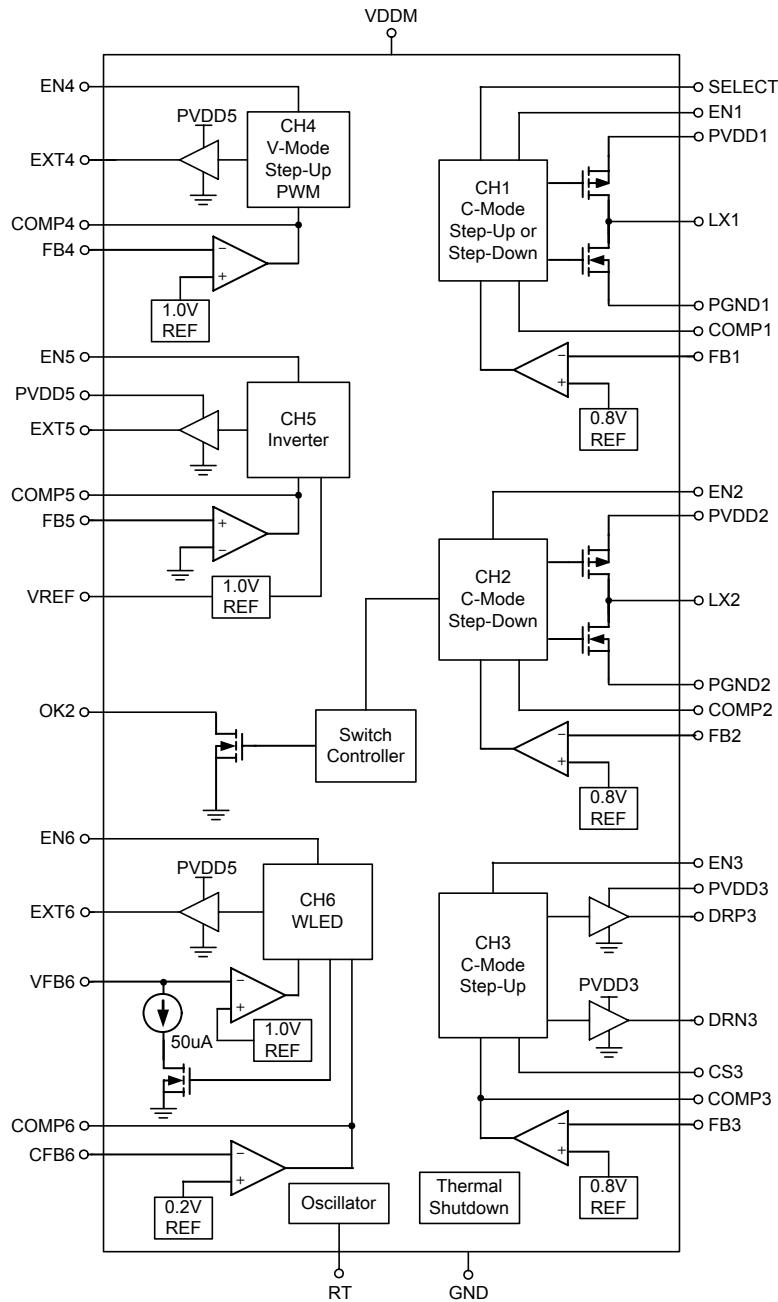

Absolute Maximum Ratings (Note 1)

- Supply Voltage, V_{DDM} ----- -0.3V to 7V
- Power Switch ----- -0.3V to ($V_{DD} + 0.3V$)
- The Other Pins ----- -0.3V to 7V
- Power Dissipation, $P_D @ T_A = 25^\circ C$
 VQFN-40L 6x6 ----- 2.778W
- Package Thermal Resistance (Note 4)
 VQFN-40L 6x6, θ_{JA} ----- 36°C/W
- Junction Temperature ----- 150°C
- Lead Temperature (Soldering, 10 sec.) ----- 260°C
- Storage Temperature Range ----- -65°C to 150°C
- ESD Susceptibility (Note 2)
 HBM (Human Body Mode) ----- 2kV
 MM (Machine Mode) ----- 200V

Recommended Operating Conditions (Note 3)

- Dimming Control Frequency Range, CH6 ----- 300Hz to 900Hz
- Supply Voltage, V_{DDM} ----- 2.4V to 5.5V
- Junction Temperature Range ----- -40°C to 125°C
- Operation Temperature Range ----- -40°C to 85°C

Electrical Characteristics

($V_{DDM} = 3.3V, T_A = 25^\circ C$, unless otherwise specified)

Parameter	Symbol	Test Conditions	Min	Typ	Max	Units
Supply Voltage						
VDDM Minimum Startup Voltage	V_{ST}	(Note 5)	--	--	1.6	V
VDDM Operating Voltage	V_{DDM}	VDDM Pin Voltage	2.4	--	5.5	V
VDDM Over Voltage Protection			5.9	6.5	--	V
Supply Current						
Shutdown Supply Current into VDDM	I_{OFF}	EN1 = EN2 = EN3 = EN4 = EN5 = EN6 = 0V	--	1	10	μA
CH1 (Sync-Boost or Syn-Buck) Supply Current into VDDM	I_{Q1}	$V_{DDM} = 3.3V$, Non-Switching	--	--	430	μA
CH2 (Sync-Buck) Supply Current into VDDM	I_{Q2}	$V_{DDM} = 3.3V$, Non-Switching	--	--	350	μA
CH3 (Sync-Boost) Supply Current into VDDM	I_{Q3}	$V_{DDM} = 3.3V$, Non-Switching	--	--	350	μA
CH4 (Asyn-Boost) Supply Current into VDDM	I_{Q4}	$V_{DDM} = 3.3V$, Non-Switching	--	--	300	μA
CH5 (Asyn-Inverter) Supply Current into VDDM	I_{Q5}	$V_{DDM} = 3.3V$, Non-Switching	--	--	300	μA
CH6 (Asyn-Boost) Supply Current into VDDM	I_{Q6}	$V_{DDM} = 3.3V$, Non-Switching	--	--	350	μA

To be continued

Parameter	Symbol	Test Conditions	Min	Typ	Max	Units
Oscillator						
Operation Frequency	f _{OSC}	RT Open	450	550	650	kHz
CH1 Maximum Duty Cycle (Boost)	D _{MAX1}	SELECT = 3.3V, V _{FB1} = 0.7V	80	85	90	%
CH1 Maximum Duty Cycle (Buck)	D _{MAX1}	SELECT = 0V, V _{FB1} = 0.7V	100	--	--	%
CH2 Maximum Duty Cycle	D _{MAX2}	V _{FB2} = 0.7V	100	--	--	%
CH3 Maximum Duty Cycle	D _{MAX3}	V _{FB3} = 0.7V	75	80	90	%
CH4 Maximum Duty Cycle	D _{MAX4}	V _{FB4} = 0.9V	90	94	98	%
CH5 Maximum Duty Cycle	D _{MAX5}	V _{FB5} = 0.1V				
CH6 Maximum Duty Cycle	D _{MAX6}	V _{CFB6} = 0.18V, V _{FB6} = 0.9V				
Feedback Regulation Voltage						
Feedback Regulation Voltage @ FB1, FB2, FB3	V _{FB1, 2,3}		0.788	0.8	0.812	V
Feedback Regulation Voltage @FB4	V _{FB4}		0.98	1	1.02	V
Feedback Regulation Voltage @ FB5	V _{FB5}		-15	--	+15	mV
Feedback Regulation Voltage @ VFB6	V _{VFB6}		--	1	--	V
Feedback Regulation Voltage @ CFB6	V _{CFB6}		0.18	0.2	0.22	V
Reference						
VREF Output Voltage	V _{REF}		0.984	1	1.016	V
VREF Load Regulation		0uA < I _{REF} < 100uA	--	--	10	mV
Error Amplifier						
GM (CH1, CH2, CH3, CH4, CH5, CH6)			--	0.2	--	ms
Compensation Source Current (CH1, CH2, CH3, CH4, CH5, CH6)			--	22	--	uA
Compensation Sink Current (CH1, CH2, CH3, CH4, CH5, CH6)			--	22	--	uA
Power Switch						
CH1 On Resistance of MOSFET	R _{DS(ON)P1}	P-MOSFET, PV _{DD1} = 3.3V	--	200	300	mΩ
	R _{DS(ON)N1}	N-MOSFET, PV _{DD1} = 3.3V	--	200	300	mΩ
CH1 Switch Current Limitation (Buck)		SELECT=0	1.3	2	4	A
CH1 Switch Current Limitation (Boost)		SELECT=1	2	2.5	4	A
CH2 On Resistance of MOSFET	R _{DS(ON)P2}	P-MOSFET, PV _{DD2} = 3.3V	--	300	450	mΩ
	R _{DS(ON)N2}	N-MOSFET, PV _{DD2} = 3.3V	--	300	450	mΩ
CH2 Switch Current Limitation			1.3	2	4	A
CH3 On Resistance of DRN3	R _{DS(ON)NP3}	P-MOSFET, PV _{DD3} = 3.3V	--	6	15	Ω
	R _{DS(ON)NN3}	N-MOSFET, PV _{DD3} = 3.3V	--	6	15	Ω
CH3 On Resistance of DRP3	R _{DS(ON)PP3}	P-MOSFET, PV _{DD3} = 3.3V	--	6	15	Ω
	R _{DS(ON)PN3}	N-MOSFET, PV _{DD3} = 3.3V	--	6	15	Ω
CH4 On Resistance of MOSFET	R _{DS(ON)P4}	P-MOSFET, PV _{DD3} = 3.3V	--	6	15	Ω
	R _{DS(ON)N4}	N-MOSFET, PV _{DD3} = 3.3V	--	6	15	Ω

To be continued

Parameter	Symbol	Test Conditions	Min	Typ	Max	Units
Power Switch						
CH5 On Resistance of MOSFET	R _{DS(ON)P5}	P-MOSFET, PV _{DD5} = 3.3V	--	6	15	Ω
	R _{DS(ON)N5}	N-MOSFET, PV _{DD5} = 3.3V	--	6	15	Ω
CH6 On Resistance of MOSFET	R _{DS(ON)P6}	P-MOSFET, PV _{DD5} = 3.3V	--	6	15	Ω
	R _{DS(ON)N6}	N-MOSFET, PV _{DD5} = 3.3V	--	6	15	Ω
Switch Controller						
OK2 pin Sink Current		OK2 = 1V	90	--	--	uA
External Current Setting (CH3)						
CS3 Sourcing Current	I _{CS3}		5	10	15	uA
VFB6 Sink Current	I _{VFB6}		40	50	60	uA
Protection						
Under Voltage Protection Threshold Voltage @ FB1, FB2		SELECT = 0V	0.3	0.4	0.5	V
Over Voltage Protection @ FB1, FB2		SELECT = 0V	--	1	--	V
Control						
EN1, EN2, EN3, EN4, EN5, EN6 Input High Level Threshold		V _{DDM} = 3.3V	--	--	1.3	V
EN1, EN2, EN3, EN4, EN5, EN6 Input Low Level Threshold		V _{DDM} = 3.3V	0.4	--	--	V
EN1, EN2, EN3, EN4, EN5, EN6 Sink Current		V _{DDM} = 3.3V	--	2	6	uA
Select Pin Input High Level Threshold			--	--	1.3	V
Select Pin Input Low Level Threshold			0.4	--	--	V
Select Pin Sink Current	I _{SELECT}		--	2	6	uA
Thermal Protection						
Thermal Shutdown	T _{SD}		125	180	--	°C
Thermal Shutdown Hysteresis	ΔT _{SD}		--	20	--	°C

Note 1. Stresses listed as the above “Absolute Maximum Ratings” may cause permanent damage to the device. These are for stress ratings. Functional operation of the device at these or any other conditions beyond those indicated in the operational sections of the specifications is not implied. Exposure to absolute maximum rating conditions for extended periods may remain possibility to affect device reliability.

Note 2. Devices are ESD sensitive. Handling precaution recommended.

Note 3. The device is not guaranteed to function outside its operating conditions.

Note 4. θ_{JA} is measured in the natural convection at T_A = 25°C on a low effective thermal conductivity test board of JEDEC 51-3 thermal measurement standard.

Note 5. A Schottky rectifier connected from LX1 to PVDD1 is required for low-voltage startup, refer to Figure 1.

Typical Operating Characteristics

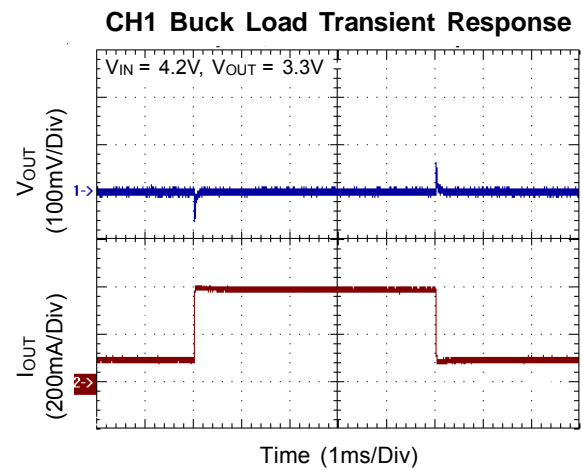
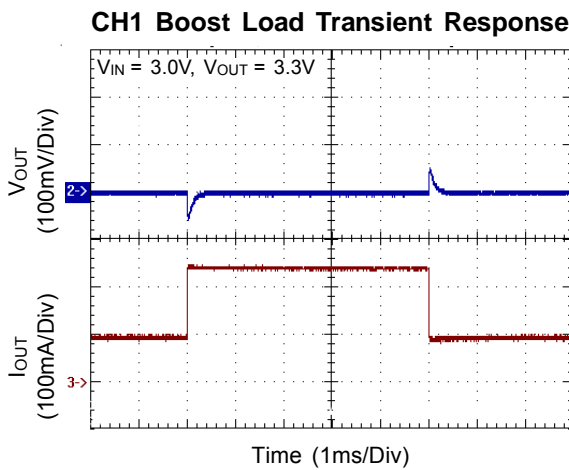
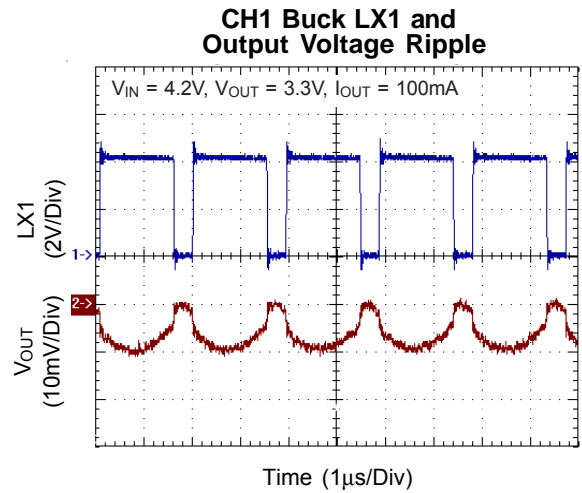
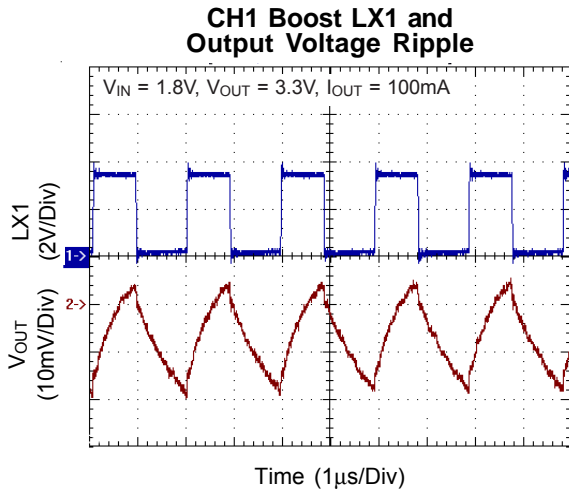
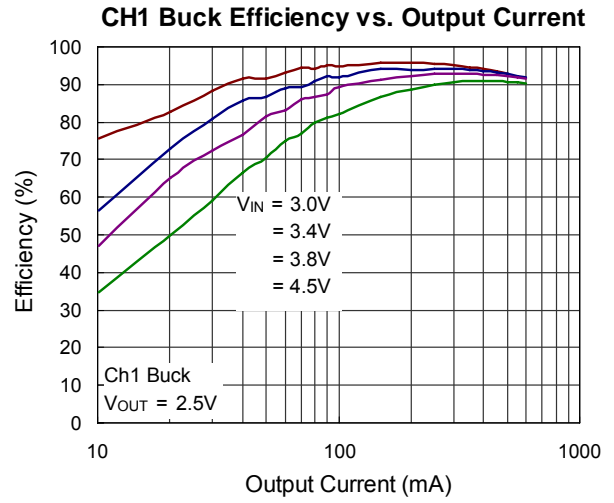
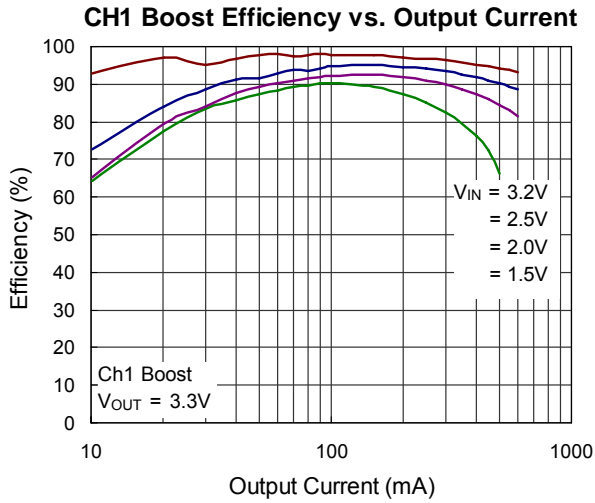

CH1 Boost Output Voltage vs. V_{DDM} Voltage

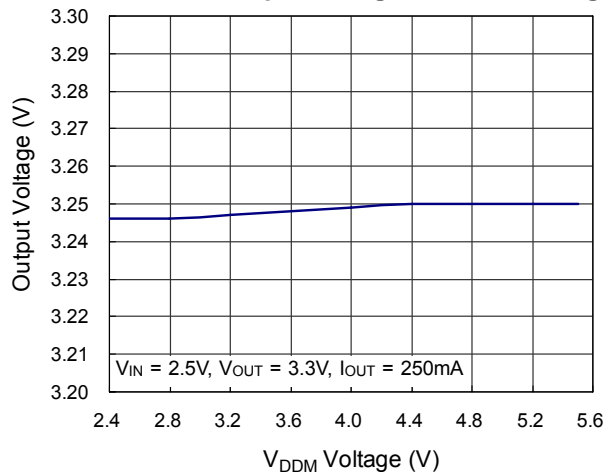

CH1 Buck Output Voltage vs. Output Current

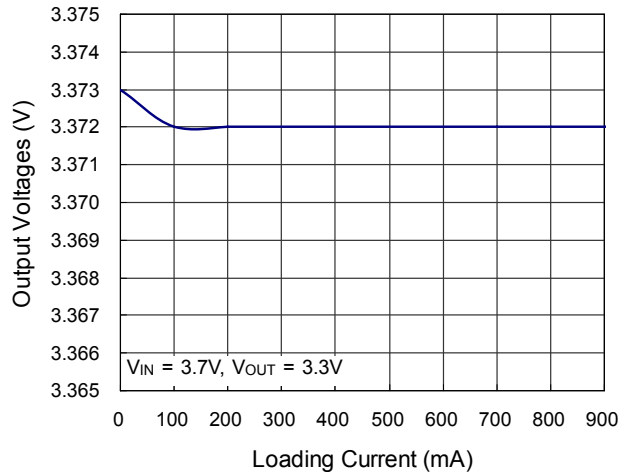

CH1 Boost Output Voltage vs. Output Current

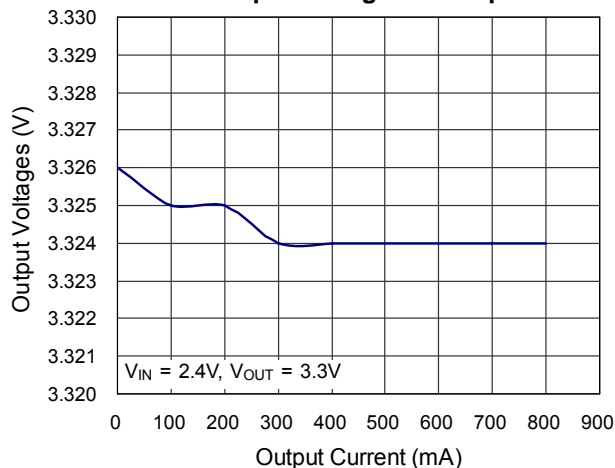

CH2 Buck Efficiency vs. Output Current

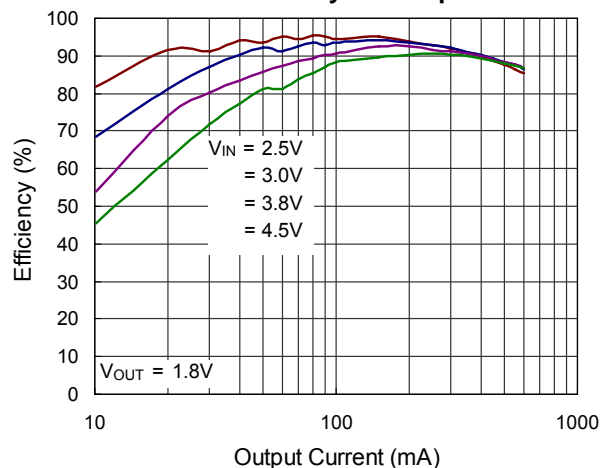

CH2 LX2 and Output Voltage Ripple

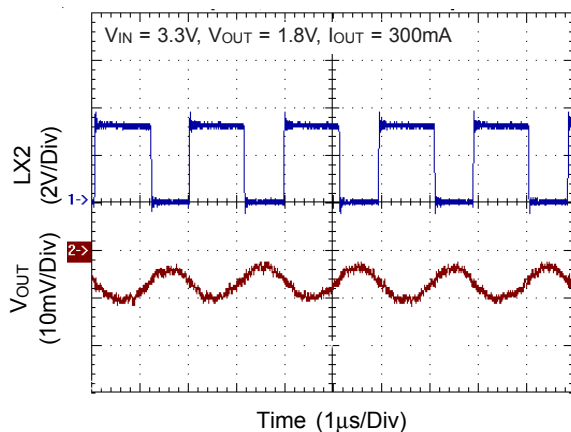

CH2 LX2 and Output Voltage Ripple

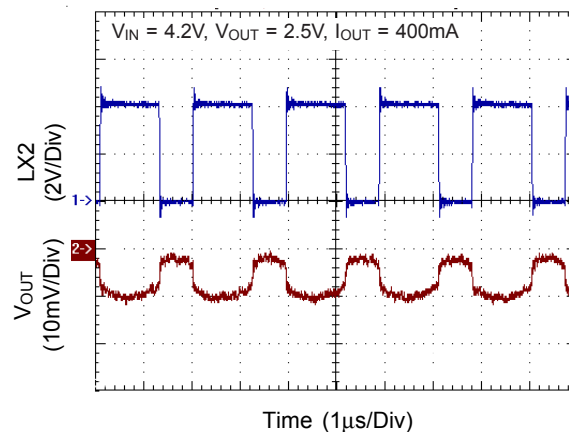

CH2 Load Transient Response

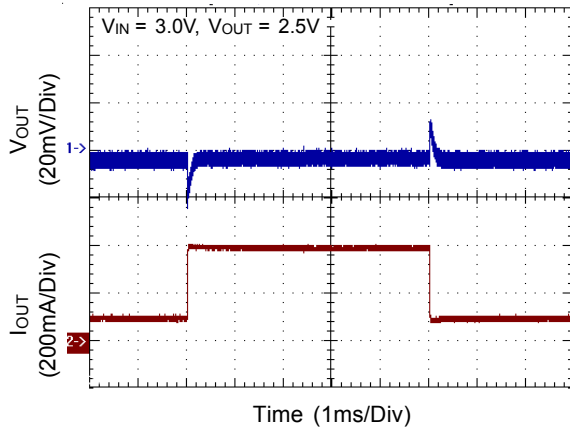

CH2 Load Transient Response

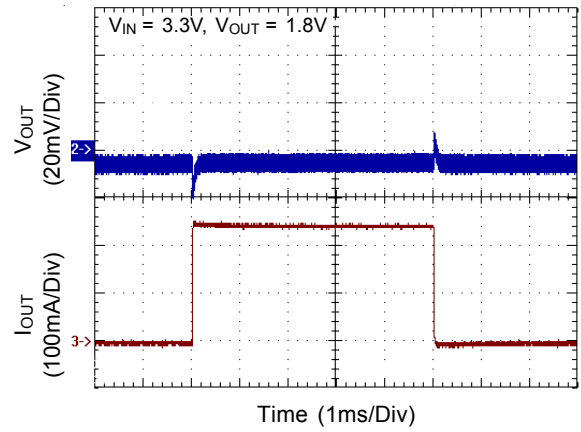

CH2 Load Transient Response

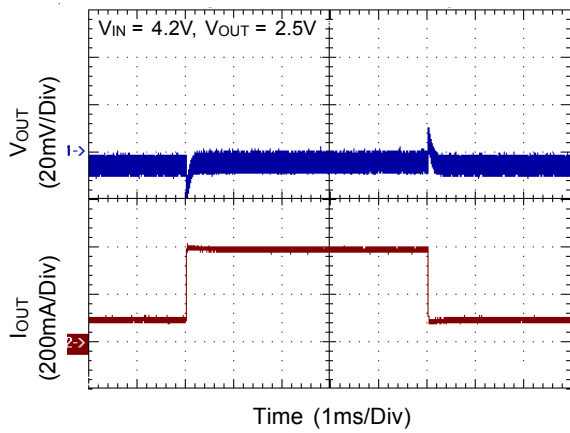

CH2 Output Voltage vs. V_{DDM} Voltage

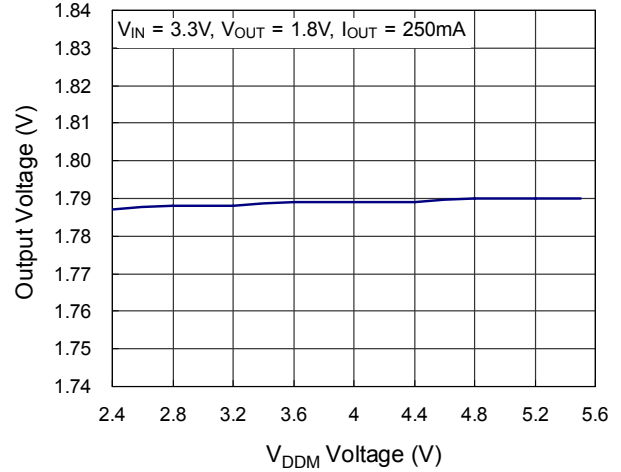

CH2 Buck Output Voltage vs. Output Current

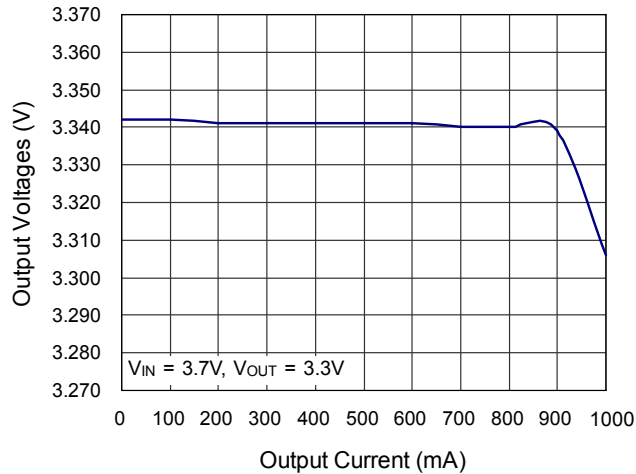

CH2 Buck Output Voltage vs. Output Current

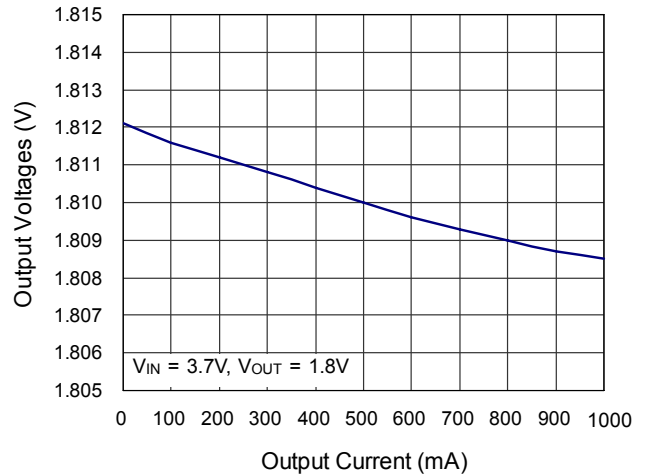

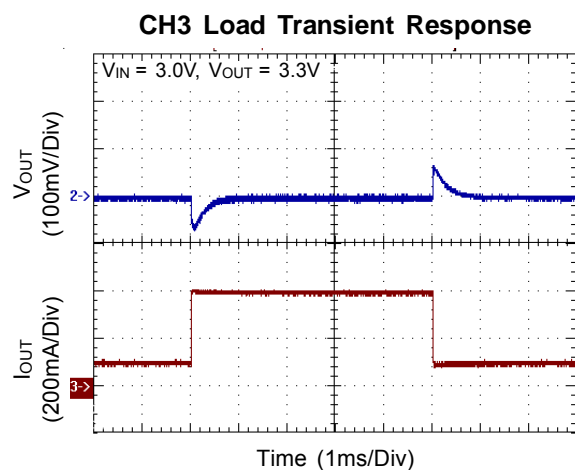
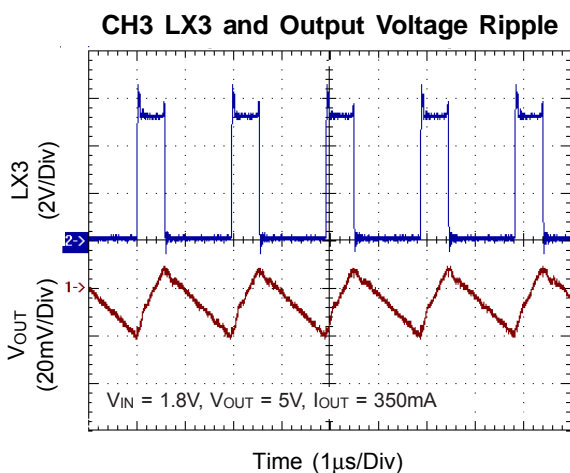
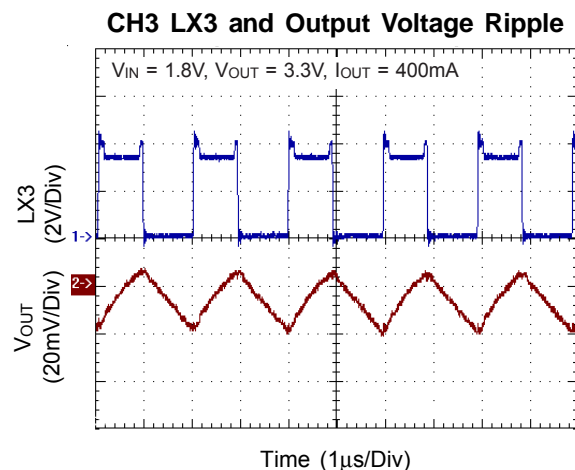
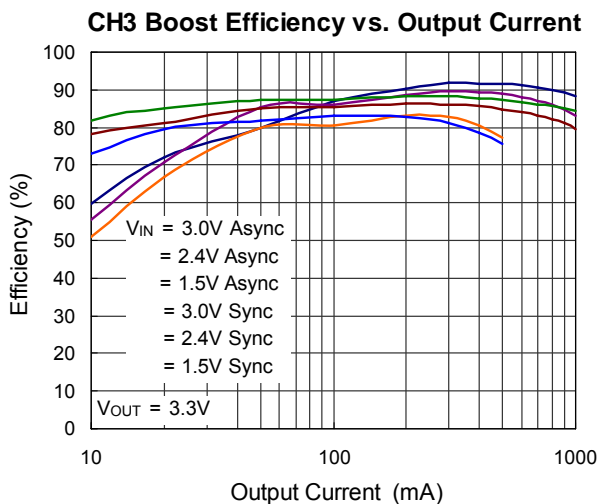
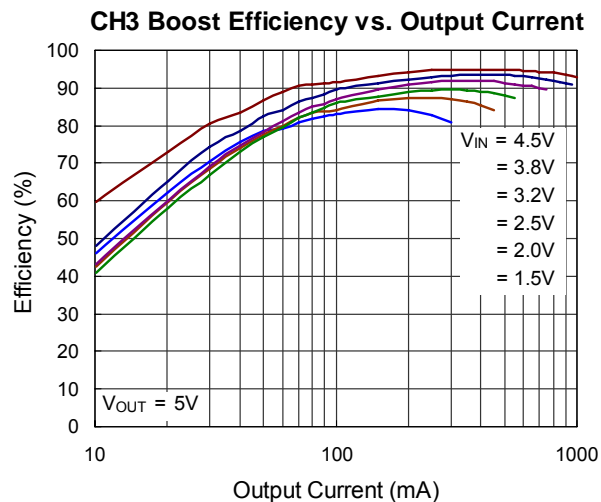
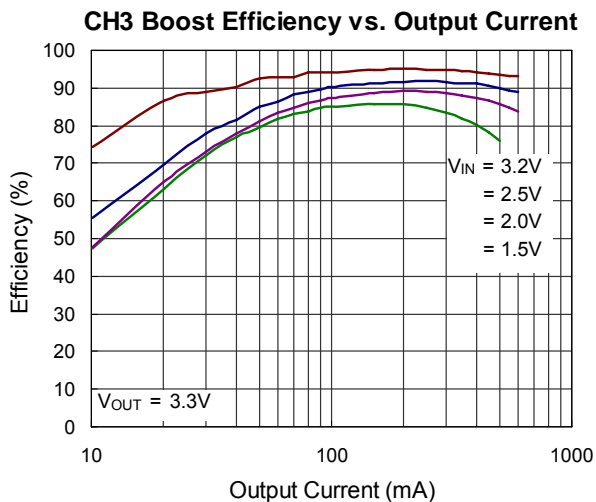

CH3 Boost Output Voltage vs. V_{DDM} Voltage

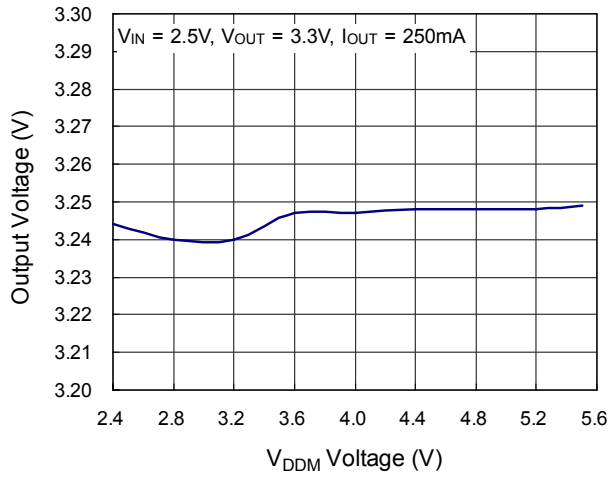

CH3 Boost Output Voltage vs. V_{DDM} Voltage

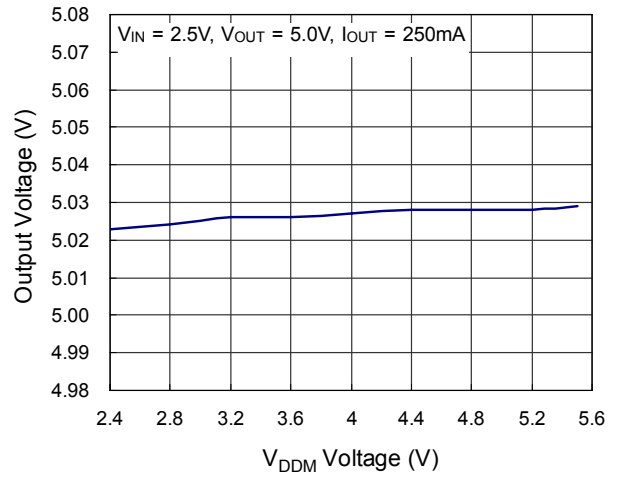

CH3 Boost Output Voltage vs. Output Current

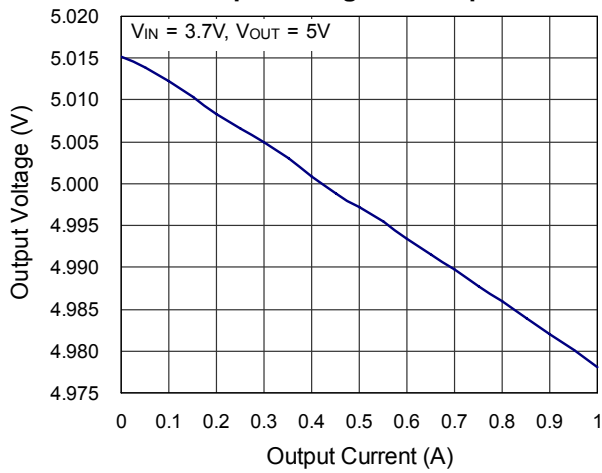

CH4 Boost Efficiency vs. Output Current

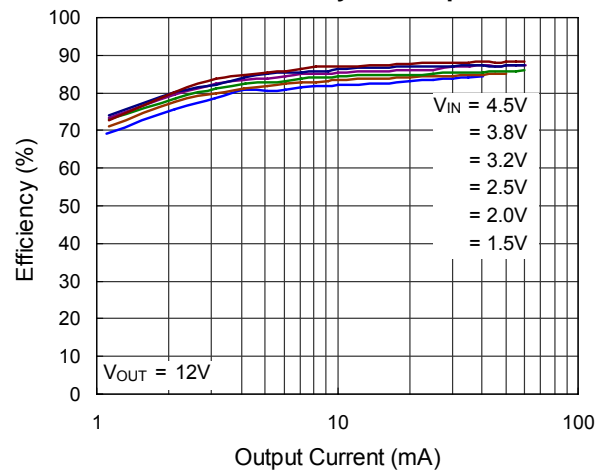

CH4 LX4 and Output Voltage Ripple

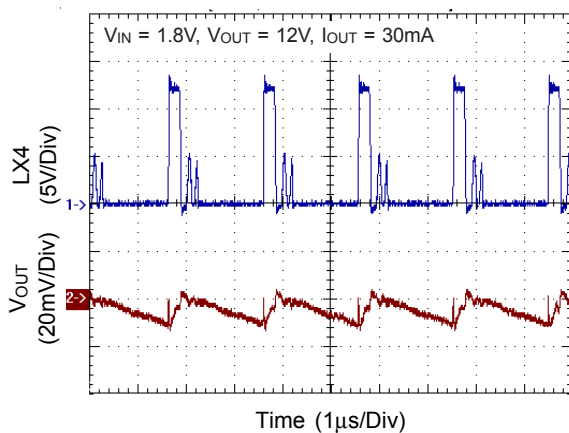

CH4 Load Transient Response

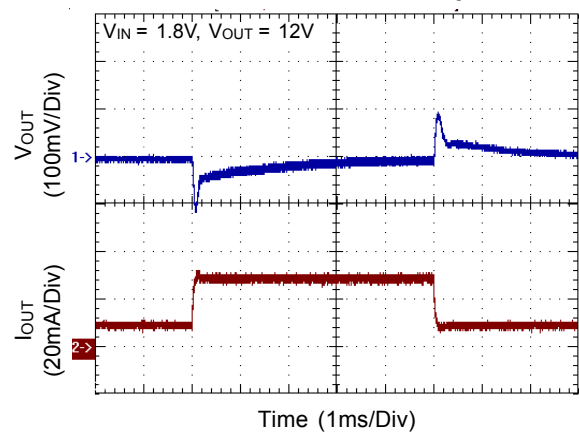

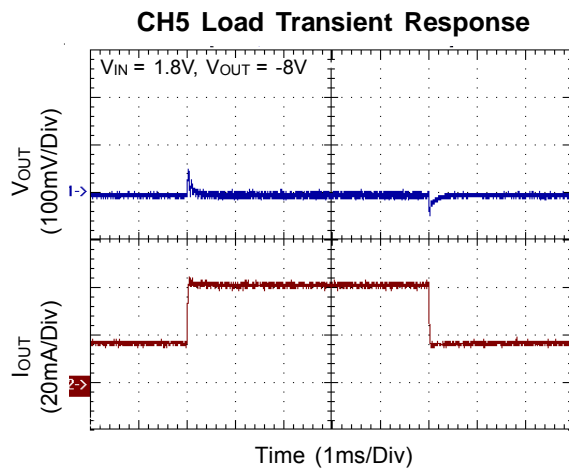
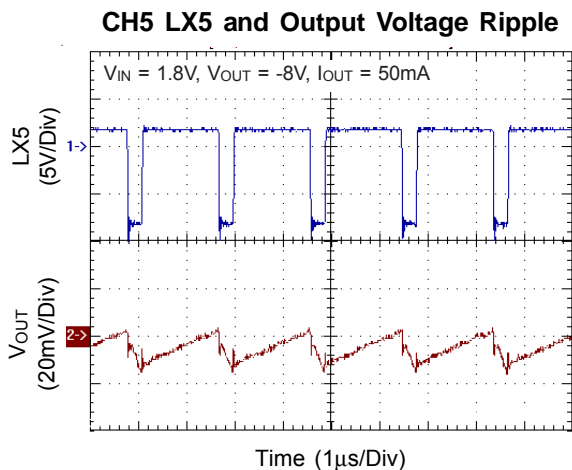
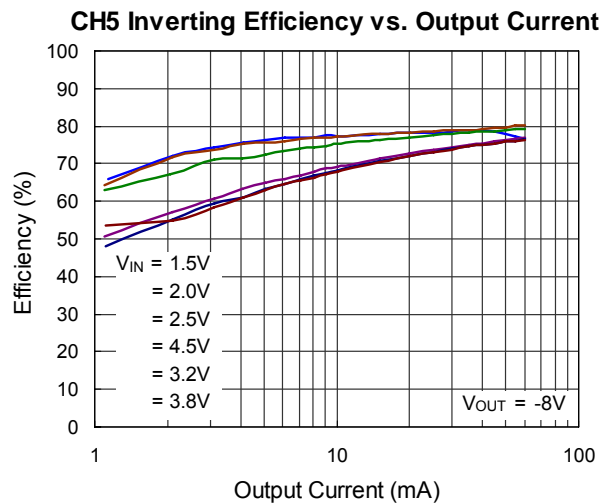
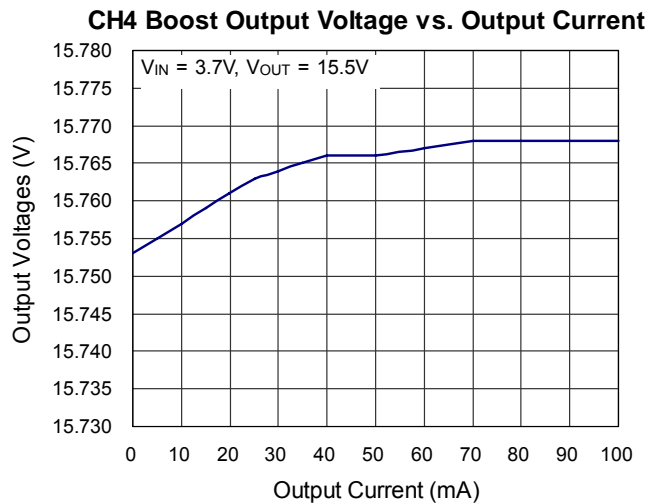
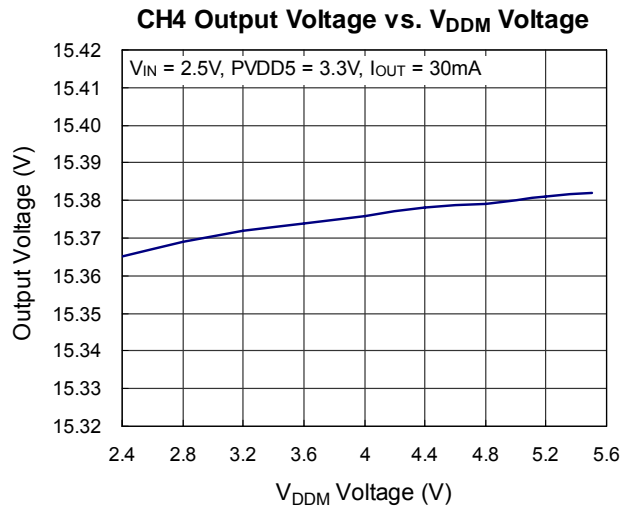
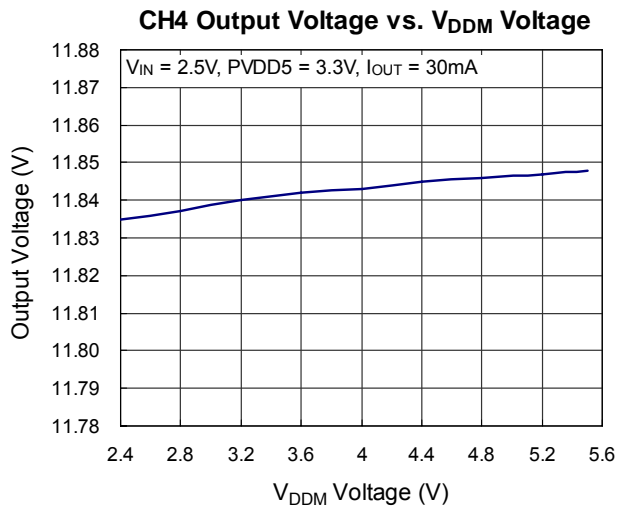

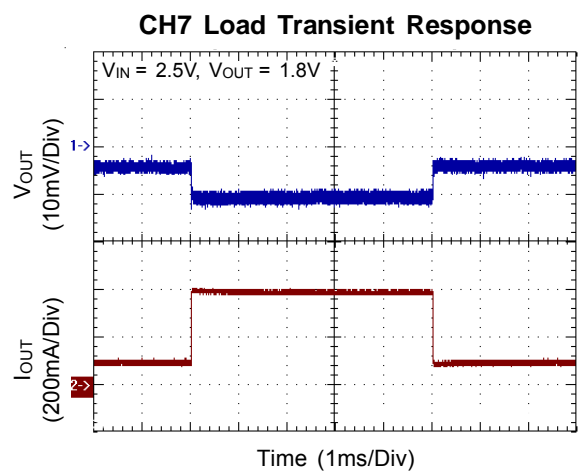
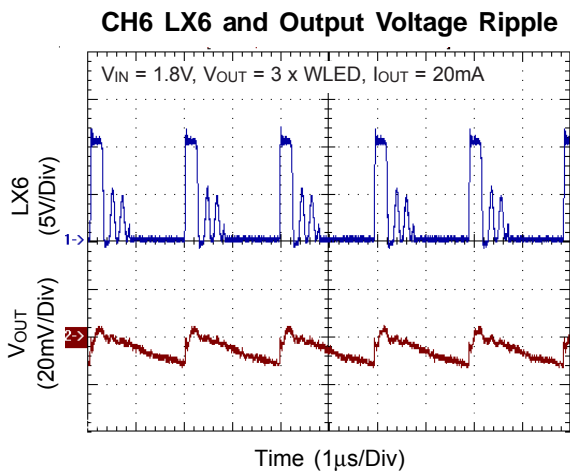
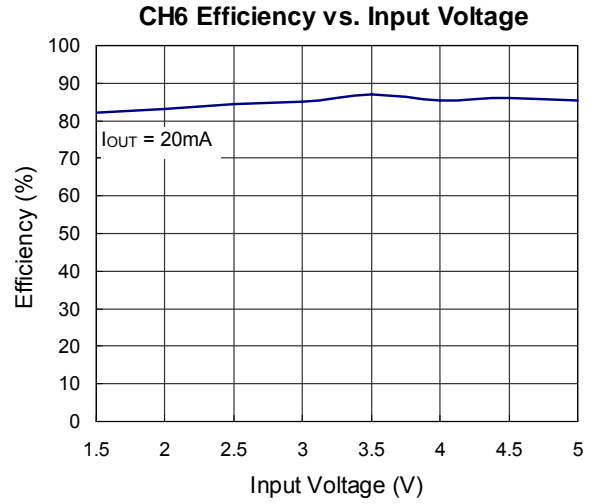
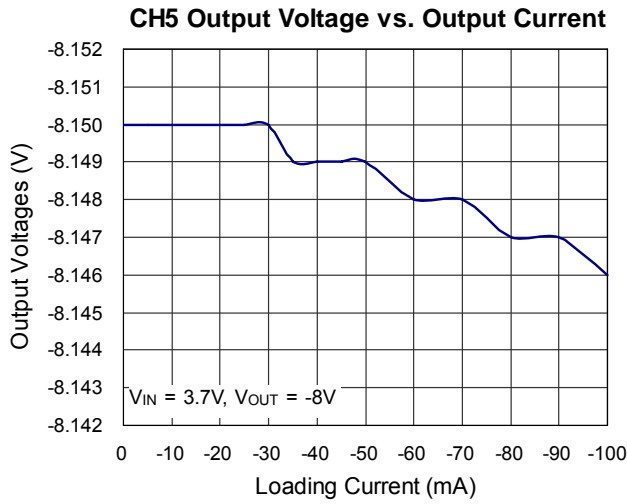
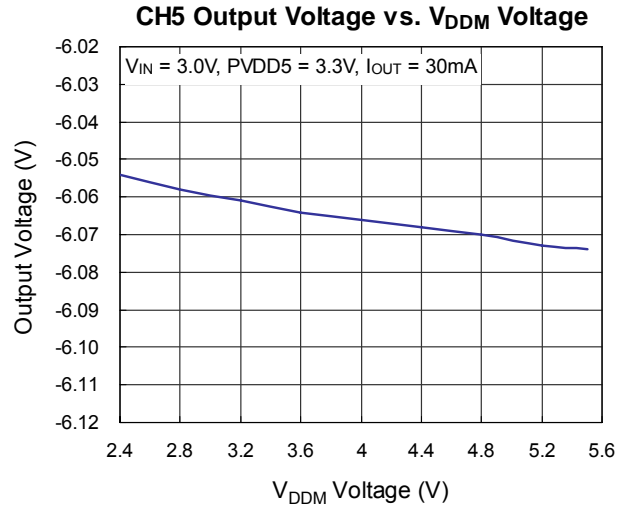
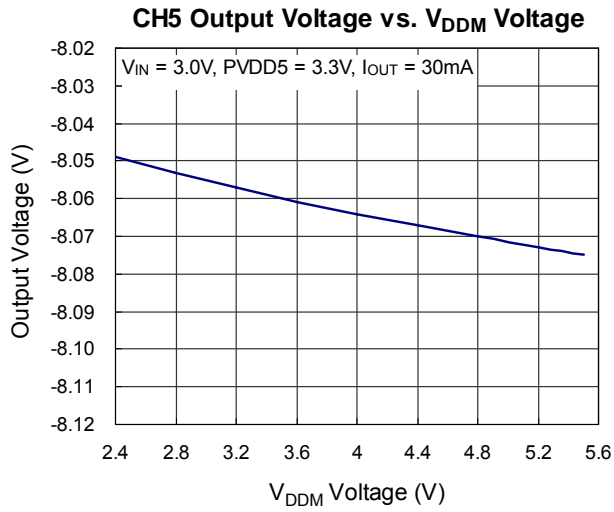

CH1 and CH2 Power Sequence

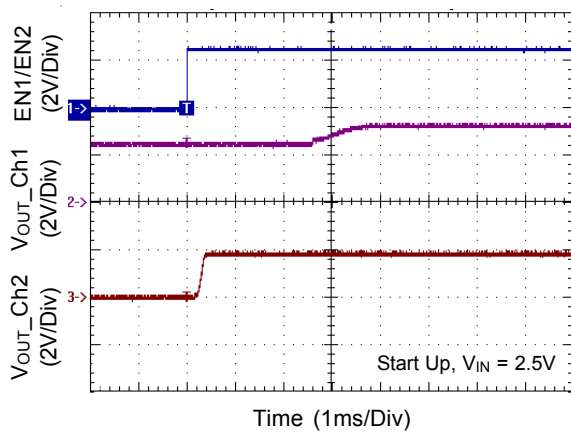

CH4 and CH5 Power Sequence

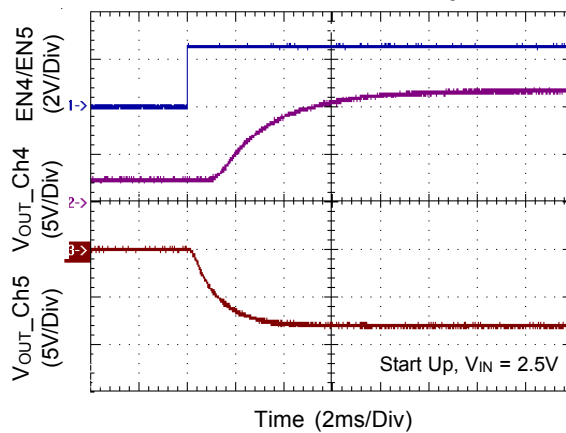

Feedback Voltage vs. Temperature

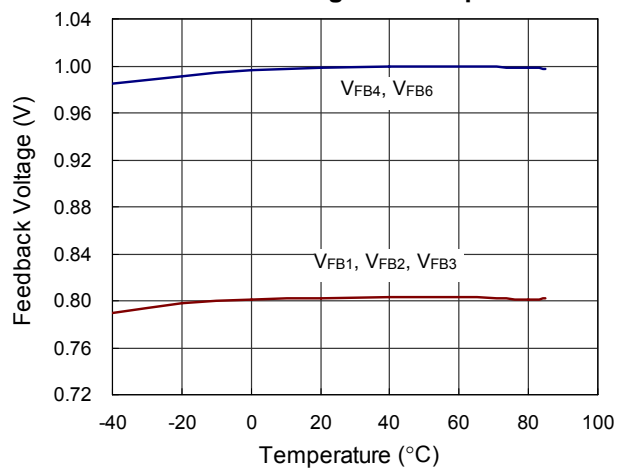

Applications Information

The RT9911 includes the following six DC/DC converter channels to build a multiple-output power-supply system.

CH1 : Selectable step-up or step-down synchronous current mode DC/DC converter with internal power MOSFETs.

CH2 : Step-down synchronous current mode DC/DC converter with internal power MOSFETs.

CH3 : Step-up asynchronous current mode DC/DC controller to drive external power MOSFETs.

CH4 : Step-up asynchronous voltage mode DC/DC controller.

CH5 : Inverting DC/DC voltage mode controller.

CH6 : DC/DC voltage mode controller for WLED as well as conventional boost application; provides open LED OVP protection.

CH1 : Selectable Step-up or Step-down Converter

CH1 is selectable as step-up (SELECT pin = logic high) or step-down (SELECT pin = logic low).

Step-up : With internal MOSFETs and synchronous rectifier, the efficiency is up to 95%. The converter always operates at fixed frequency PWM mode and CCM (continuous current mode).

Step-down : With internal MOSFETs and synchronous rectifier, the efficiency is up to 95%. The converter always operates at fixed frequency PWM mode and CCM. While the input voltage is close to output voltage, the converter enters low dropout mode. Duty could be as long as 100% to extend battery life. See Figure 3(a) for detailed functional block.

CH2 : Step-down DC/DC Converter

With internal MOSFETs and synchronous rectifier, the efficiency is up to 95%. The converter always operates at fixed frequency PWM mode and CCM. While the input voltage is close to output voltage, the converter enters low dropout mode. Duty could be as long as 100% to extend battery life. See Figure 3(b) for detailed functional block.

CH3 : Step-up DC/DC Controller

With external MOSFETs and a synchronous rectifier, the efficiency is up to 97%. The converter always operates at fixed frequency PWM mode and CCM. The threshold of current limit is estimated by $R_{DS(ON)}$ of external NMOS. See **Protections** for detailed information and detailed functional block in Figure 3(c).

CH4, CH6 : Step-up DC/DC Controller

CH4 and CH6 are fixed frequency voltage mode PWM controllers. EXT4 and EXT6 pins are designed to drive external NMOS switch. CH6 is optimized for WLED application. CFB6 is current-sensing feedback, and VFB6 provides over voltage protection (WLED open circuit). See **Protections** for detailed information and detailed functional block in Figure 3(d for CH4 and e for CH6).

CH5 : Inverting Controller

CH5 is a voltage mode, fixed frequency PWM controller to generate negative output voltage. EXT5 is designed to drive external PMOS switch. To turn off PMOS completely, please note that PVDD5 should not be lower than the source voltage of PMOS. See Figure 3(f) for detailed functional block.

Reference Voltage

RT9911 provides a precise 1V reference voltage with sourcing capability 100uA. Connect a 1uF ceramic capacitor from VREF pin to GND. Reference voltage is enabled by connecting EN5 to logic high.

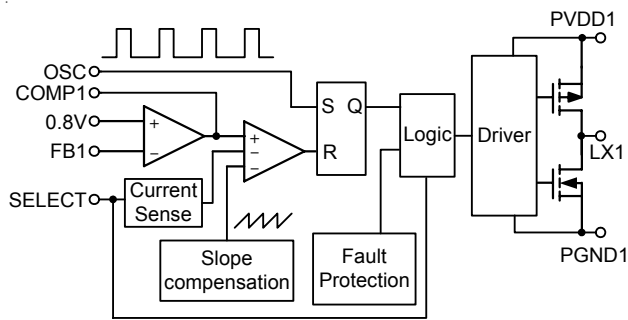

Figure 3(a)

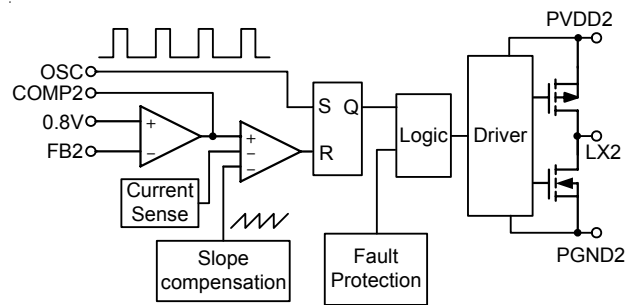

Figure 3(b)

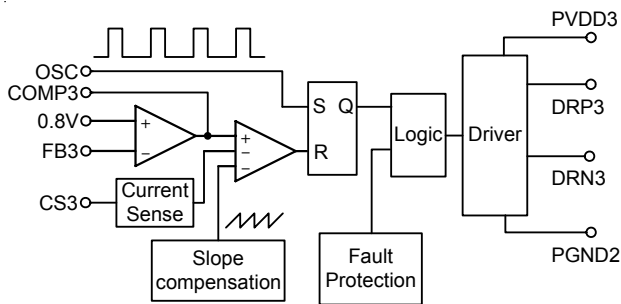

Figure 3(c)

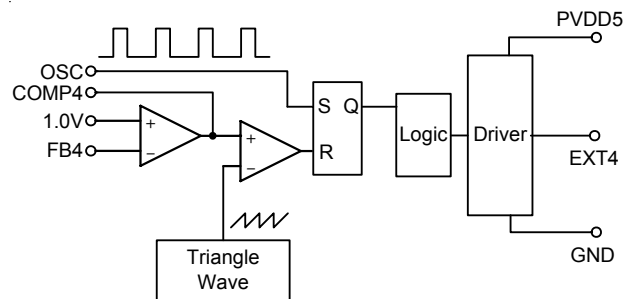

Figure 3(d)

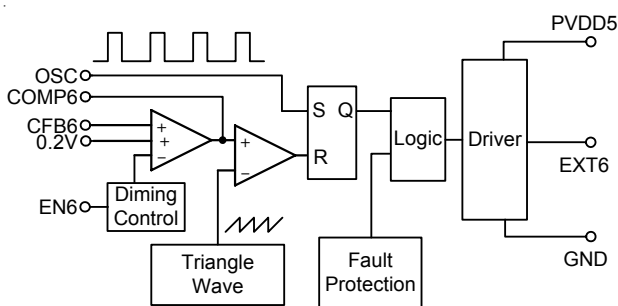

Figure 3(e)

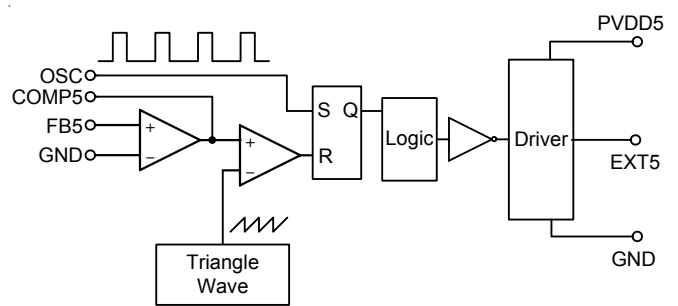
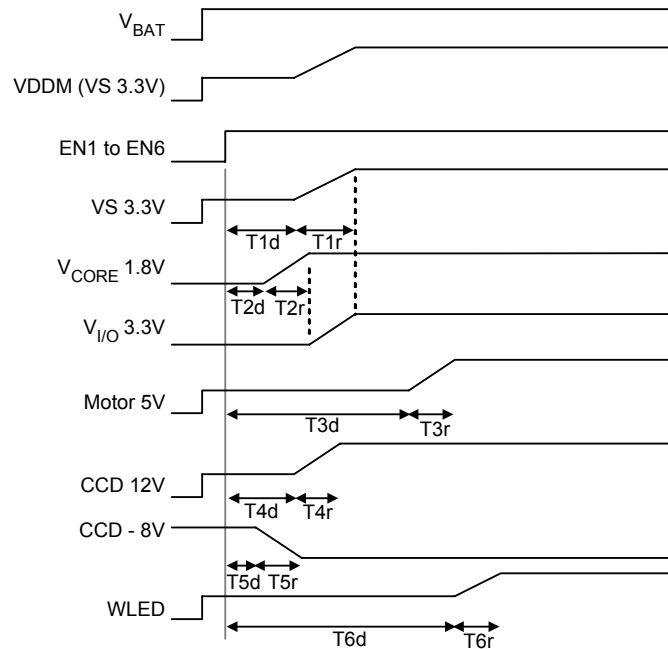

Figure 3(f)

Figure 3. Detailed Functional Block for each channel



Note :

- Please refer to Figure 1 for application Information.
- Timing sequence should be controlled by EN pins.

Figure 4. Timing Diagram

Calculation method:

Td1 to Td6 are precise value. Tr1 to Tr6 are approximation.

Units : T in second, C in Farad, R in Ohm

C31 to C36 : Compensation capacitor of CH1 to CH6.

$$T1d = 0.7V \times C31 / 2\mu A \quad (\text{CH1 Boost})$$

$$T1d = 0.7V \times C31 / 2\mu A \quad (\text{CH1 Buck})$$

$$T2d = 0.35V \times C32 / 2\mu A$$

$$T3d = 0.7V \times C33 / 2\mu A$$

$$T4d = 0.35V \times C34 / 2\mu A$$

$$T5d = 0.85V \times C35 / 2\mu A$$

$$T6d = 0.85V \times C36 / 2\mu A$$

$$T1r = (0.5V \times D1 + 0.48A \times R_{DS(ON)_N} \times C31) / 1.25\mu A \quad @ \text{ No load (Boost)}$$

$$T1r = (0.33V \times D1 + 0.2A \times R_{DS(ON)_P} \times C31) / 1.25\mu A \quad @ \text{ No load (Buck)}$$

$$T2r = (0.33V \times D2 + 0.2A \times R_{DS(ON)_P} \times C32) / 1.25\mu A \quad @ \text{ No load}$$

$$T3r = (0.5V \times D3 + 0.8A \times R_{DS(ON)_N} \times C33) / 3.6\mu A \quad @ \text{ No load}$$

$$T4r = (1.0V \times D4) \times C34 / 1\mu A \quad @ \text{ No load}$$

$$T5r = (1.0V \times D5) \times C35 / 1\mu A \quad @ \text{ 1mA min. load}$$

$$T6r = (0.25V \times D6) \times C36 / 2.6\mu A \quad @ \text{ 4 WLEDs}$$

where

$$D1 = 1 - (V_{BAT} / V_{VS\ 3.3V}) \quad (\text{Boost})$$

$$D1 = V_{VS\ 3.3V} / V_{BAT} \quad (\text{Buck})$$

$$D2 = V_{V_{CORE\ 1.8V}} / V_{BAT}$$

$$D3 = 1 - (V_{BAT} / V_{Motor\ 5V})$$

$$D4 = 1 - (V_{BAT} / V_{CCD\ 12V})$$

$$D5 = |V_{CCD\ -8V}| / (V_{BAT} + |V_{CCD\ -8V}|)$$

$$D6 = 1 - (V_{BAT} / V_{WLED})$$

Example : $T1d = 0.7V \times 1nF / 2\mu A = 350 \text{ us (Boost)}$

$$T1r = (0.5 \times (1 - 1.8/3.3) + 0.48 \times 0.2) \times 1nF / 1.25\mu A = 258 \text{ us}$$

Oscillator

The internal oscillator synchronizes CH1 to CH6 with fixed operation frequency. The frequency could be set by connecting resistor between RT pin to GND. See Figure 5 to adjust frequency.

Soft Start

With internal soft start mechanism, the soft start time of each channel is proportional to the compensation capacitor. Refer to the soft start waveform in Figure 4 for typical application.

Protection

RT9911 provides versatile protection functions. Protection type, threshold and protection methods are summarized in Table 1.

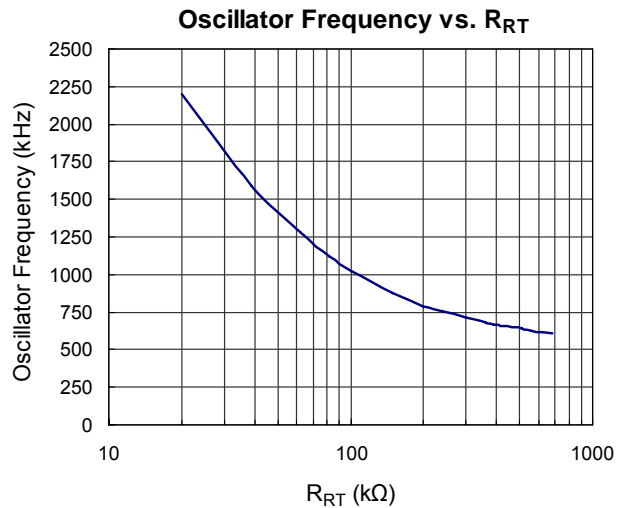

Figure 5. Adjust Frequency

Table 1

	Protection type	Threshold (typical) Refer to Electrical spec	Protection methods	Reset method
VDDM	Over Voltage Protection	VDDM > 6.5V	Disable all channels	Restart if VDDM < 6.5V
CH1: Boost	Current Limit	NMOS current > 2.5A	NMOS latched off	Automatic reset at next clock cycle
CH1: Buck	Current Limit	PMOS current > 2.0A	PMOS latched off and all channels shutdown	VDDM power reset
	Under Voltage Protection	FB1 < 0.4V	NMOS, PMOS latch off and all channels shutdown	VDDM power reset
	Over Voltage Protection	FB1 > 1.0V	NMOS, PMOS latch off and all channels shutdown	VDDM power reset
CH2	Current Limit	PMOS current > 2.0A	PMOS latched off and all channels shutdown	VDDM power reset
	Under Voltage Protection	FB2 < 0.4V	NMOS, PMOS latch off and all channels shutdown	VDDM power reset
	Over Voltage Protection	FB2 > 1.0V	NMOS, PMOS latch off and all channels shutdown	VDDM power reset
CH3	Current Limit	CS3 > 0.3V, see below Note	NMOS latched off	Automatic reset at next clock cycle
CH6	Over Voltage Protection	VFB6 > 1.0V, see Figure 8	NMOS off	VFB6 < 1.0V
Thermal	Thermal shutdown	Temperature > 180°C	All channels stop switching	Temperature < 160°C

Note : If $R_{DS(ON)} \times I_{inductor} > 0.3V$, then current limit happens.

For example, if select NMOS (AOS3402), $R_{DS(ON)} = 110m\Omega$ (at $V_{GS} = 2.5V$), then current limit happens if $I_{inductor} > 2.73A$.

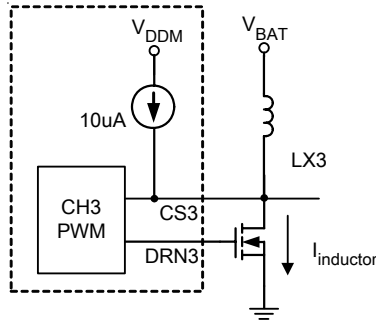

Figure 6. CH3 Current Limit Setting

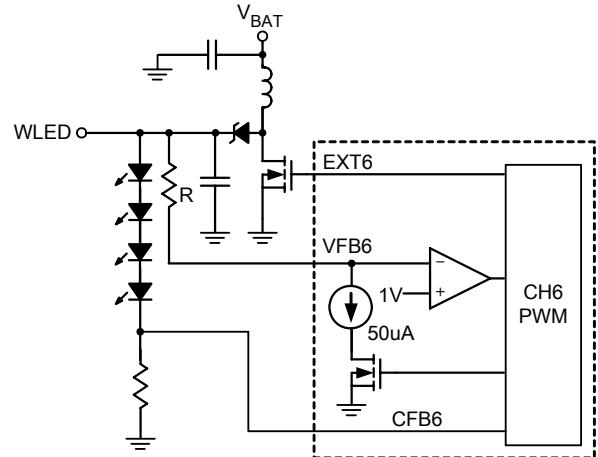

Figure 8. CH6 Over Voltage Protection Method
($V_{WLED} > 50\mu A \times R + 1V$, protection happens)

RT9911 Component Selection for Compensation :

CH1 Sync-Boost (Select Pin = High Logic) :

CH1 sync-boost converter employs current-mode control to simplify the control loop compensation. There is a RHPZ (Right Hand Plane Zero) appeared in the loop-gain frequency response when a boost converter operates with continuous inductor current (typically the case), we also call it works in CCM (Continuous Current Mode). For stability, cross over frequency (f_c), unity gain frequency, must lower than this RHPZ frequency.

The fixed parameters for CH1 boost compensation are as follows :

- Transconductance (from FB to COMP), $GM = 200\mu S$
- Current sense transresistance, $R_{CS} = 0.4V/A$
- Feedback voltage, $V_{FB} = FB = 0.8V$

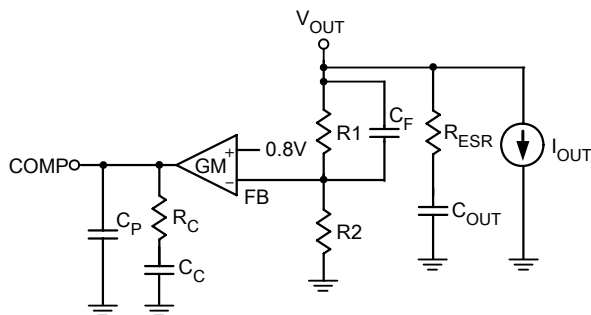

Figure 7

The input parameters for CH1 boost compensation are as follows:

- R_1 , the voltage divider resistor in between V_{OUT} and FB.
- V_{IN} , input voltage.
- V_{OUT} , desired output voltage
- $I_{OUT(MAX)}$, maximum output load
- F_{OSC} , operating frequency
- L , inductance
- R_{ESR} , ESR (Equivalent Series Resistance) of C_{OUT} (ceramic output capacitor)
- $T_{DRP}(\%)$, Transient droop.

The results we will get for CH1 boost compensation are as follows:

- R_2 , the voltage divider resistor in between FB and ground.
- C_F , feedforward capacitor in parallel with R_1 .
- R_C , compensation resistor on COMP pin.
- C_C , compensation capacitor in series with R_C and connect to ground.
- C_P , connect in between COMP pin and ground. (Can be ignored if $C_P < 10pF$).
- C_{OUT} , output capacitance. This compensation is based on ceramic output capacitor.

The major steps for getting above results :

1. $R_2 = R_1 \times \left(\frac{V_{FB}}{V_{OUT} - V_{FB}} \right)$
2. Find RHPZ(Right Hand Plan Zero) location.
 $RHPZ(\text{Boost}) = R_{LOAD} \times \frac{(1-D)^2}{2\pi L}$, Where
 $R_{LOAD} = \frac{V_{OUT}}{I_{OUT(\text{MAX.})}}$, $D = \text{Duty Cycle} = 1 - \frac{V_{IN}}{V_{OUT}}$

3. Set f_c (cross over frequency) sufficiently below RHPZ.

For example : $f_c = RHPZ/6$

4. Get $C_C = \left(\frac{R_{LOAD}}{R_{CS}} \right) \times \frac{GM}{2\pi f_c} \times \frac{V_{FB}}{V_{OUT}} \times (1-D)$
5. Select R_C based on the allowed transient droop.
 $R_C = dl \times \left(\frac{1}{(1-D)} \right) \times \frac{R_{CS}}{GM \times dV_{FB}}$
 , where $dl = \text{transient step}$, $dV_{FB} = T_{DRP}(\%) \times V_{FB}$
6. Get $C_{OUT} = \frac{R_C \times C_C}{R_{LOAD}}$

7. Find ffz , zero and ffp , pole ratio of voltage divider with C_F .
 $\text{ratio} = \frac{ffz}{ffp} = \frac{V_{OUT}}{V_{FB}}$

8. Get C_F by placing ffp on f_c and ffz therefore on $\frac{f_c}{\text{ratio}}$.
 $C_F = \frac{1}{2 \times \pi \times ffz \times R_1}$, where $ffz = \frac{f_c}{\text{ratio}}$

9. Evaluate C_P . C_P is for canceling the zero from C_{OUT} (ceramic output capacitor).
 $C_P = C_{OUT} \frac{R_{ESR}}{R_C}$. C_P can be ignore if $C_P < 10pF$.

Example : Set $R_1 = 470k\Omega$, $V_{IN} = 1.8V$, $V_{OUT} = 3.3V$,
 $V_{FB} = 0.8V$, $I_{OUT(\text{MAX.})} = 0.5A$, $f_{OSC} = 500kHz$, $L = 4.7\mu H$,
 $R_{ESR} = 5m\Omega$, and half-load transient droop is 5%.

Results:

1. $R_2 = R_1 \frac{V_{FB}}{V_{OUT} - V_{FB}} = 470k \frac{0.8}{3.3 - 0.8} = 150k\Omega$
2. $RHPZ(\text{Boost}) = R_{LOAD} \frac{(1-D)^2}{2\pi L} = 66.3kHz$, where
 $R_{LOAD} = \frac{V_{OUT}}{I_{OUT(\text{MAX.})}} = 6.6\Omega$, $(1-D) = \frac{V_{IN}}{V_{OUT}} = 0.54$
3. $f_c = \frac{RHPZ}{6} = 11kHz$

$$4. C_C = \frac{R_{LOAD}}{2\pi f_c} \frac{GM}{R_{CS}} \times \left(\frac{V_{FB}}{V_{OUT}} \right) \times (1-D) = 6.3nF.$$

Choose 6.8nF.

Half-load transient means load from 0.25A to 0.5A transient. So, $dl = 0.5 - 0.25 = 0.25A$

$$dV_{FB} = T_{DRP}(\%) \times V_{FB} = 5\% \times 0.8 = 0.04V.$$

Thus,

$$5. R_C = \frac{dl \left(\frac{1}{(1-D)} \right) \times R_{CS}}{GM \times dV_{FB}} = 23k\Omega$$

$$6. C_{OUT} = \frac{R_C \times C_C}{R_{LOAD}} = \frac{23k \times 6.8n}{6.6} = 22\mu F.$$

$$7. \text{ratio} = \frac{ffp}{ffz} = \frac{V_{OUT}}{V_{FB}} = \frac{3.3}{0.8} = 4.1$$

$$8. C_F = \frac{1}{2\pi \times ffz \times R_1} = 126pF, \text{ where}$$

$$ffz = \frac{f_c}{\text{ratio}} = \frac{11k}{4.1} = 2.68kHz$$

Choose $C_F = 150pF$

$$9. C_P = \frac{C_{OUT} \times R_{ESR}}{R_C} = \frac{22\mu F \times 0.005}{23k} = 4.8pF,$$

which is less than 10pF. So, It can be ignored.

CH1 Sync-Buck (Select Pin = Low Logic) and CH2 Sync-Buck :

CH1 sync-buck (select pin=low logic) and CH2 sync-buck are converters employ current-mode control to simplify the control loop compensation. There is no RHPZ (Right Hand Plan Zero) in the buck topology but there is a high frequency pole $f_{HP} \geq f_{OSC} / \pi$. The f_c (cross over frequency) is chosen sufficient less than f_{HP} .

The fixed parameters for CH1 and CH2 buck compensation are as follows:

- Transconductance (from FB to COMP), $GM = 200us$
- Current sense transresistance, $R_{CS} = 0.3V/A$
- Feedback voltage, $V_{FB} = FB = 0.8V$

The input parameters for CH1 and CH2 buck compensation are as follows:

- R_1 , the voltage divider resistor in between V_{OUT} and FB.

- V_{IN} , input voltage.
- V_{OUT} , desired output voltage
- $I_{OUT(MAX.)}$, maximum output load
- f_{OSC} , operating frequency
- L , inductance
- R_{ESR} , ESR (Equivalent Series Resistance) of C_{OUT} (ceramic output capacitor)
- $T_{DRP}(\%)$, Transient droop.

The results we will get for CH1 boost compensation are as follows:

- R_2 , the voltage divider resistor in between FB and ground.
- C_F , feedforward capacitor in parallel with R_1 .
- R_C , compensation resistor on COMP pin.
- C_C , compensation capacitor in series with R_C and connect to ground
- C_P , connect in between COMP pin and ground. (Can be ignored if $C_P < 10pF$)
- C_{OUT} , output capacitance. This compensation is based on ceramic output capacitor.

The major steps for getting above results :

$$1. R_2 = R_1 \frac{V_{FB}}{V_{OUT} - V_{FB}}$$

2. Set f_c (cross over frequency) sufficiently below f_{OSC} .

$$\text{For example : } f_c = \frac{f_{HP}}{4}$$

$$3. C_C = \frac{R_{LOAD}}{R_{CS}} \times \frac{GM}{2\pi f_c} \times \frac{V_{FB}}{V_{OUT}}$$

$$4. R_C = \frac{dI \times R_{CS}}{GM \times dV_{FB}}, \text{ where } dI = \text{transient step,}$$

$$dV_{FB} = T_{DRP}(\%) \times V_{FB}$$

$$5. \text{ Get } C_{OUT} = \frac{R_C \times C_C}{R_{LOAD}}$$

6. Find ff_z , zero and ff_p , pole ratio of voltage divider with C_F .

$$\text{ratio} = \frac{ff_p}{ff_z} = \frac{V_{OUT}}{V_{FB}}$$

7. Get C_F by placing ff_p on f_c and ff_z therefore on $\frac{f_c}{\text{ratio}}$.

$$C_F = \frac{1}{2\pi \times ff_z \times R_1}, \text{ where } ff_z = \frac{f_c}{\text{ratio}}$$

8. Evaluate C_P . C_P is for canceling the zero from C_{OUT} (ceramic output capacitor).

$$C_P = \frac{C_{OUT} \times R_{ESR}}{R_C}. C_P \text{ can be ignore if } C_P < 10pF.$$

Example : Set $R_1 = 470k\Omega$, $V_{IN} = 3V$, $V_{OUT} = 1.8V$,

$V_{FB} = 0.8V$, $I_{OUT(MAX.)} = 0.5A$, $f_{OSC} = 500kHz$, $L = 4.7\mu H$,

$R_{ESR} = 5m\Omega$, and half-load transient droop is 5%.

Results :

$$1. R_2 = R_1 \times \frac{V_{FB}}{V_{OUT} - V_{FB}} = 470k \times \frac{0.8}{1.8 - 0.8} = 376k\Omega$$

$$2. f_c = \frac{f_{HP}}{4} = \frac{f_{OSC}}{4\pi} = 40kHz$$

$$3. C_C = \frac{R_{LOAD}}{R_{CS}} \times \frac{GM}{2\pi f_c} \times \frac{V_{FB}}{V_{OUT}} = 4.25nF, \text{ where}$$

$$R_{LOAD} = \frac{V_{OUT}}{I_{OUT(MAX.)}} = 3.6\Omega$$

Choose 4.7nF.

Half-load transient means load from 0.25A to 0.5A transient. So, $dI = 0.5 - 0.25 = 0.25A$

$$dV_{FB} = T_{DRP}(\%) \times V_{FB} = 5\% \times 0.8 = 0.04V.$$

Thus,

$$4. R_C = dI \frac{R_{CS}}{GM \times dV_{FB}} = 9.4k\Omega, \text{ choose } 10k\Omega.$$

$$5. C_{OUT} = \frac{R_C \times C_C}{R_{LOAD}} = \frac{10k \times 3.9nF}{3.6} = 10.8\mu F. \text{ Choose } 10\mu F.$$

$$6. \text{ ratio} = \frac{ff_p}{ff_z} = \frac{V_{OUT}}{V_{FB}} = \frac{1.8}{0.8} = 2.25$$

$$7. C_F = \frac{1}{2\pi \times ff_z \times R_1} = 15.2pF, \text{ where}$$

$$ff_z = \frac{f_c}{\text{ratio}} = \frac{50k}{2.25} = 22.2kHz$$

Choose $C_F = 22pF$

$$8. C_P = \frac{C_{OUT} \times R_{ESR}}{R_C} = \frac{10\mu \times 0.005}{10k} = 5pF,$$

which is less than 10pF. So, It can be ignored.

CH3 Syn Boost Controller with External MOSFET :

CH3 boost controller driving external logic level MOSFET employs current-mode control to simplify the control loop compensation. There is a RHPZ (Right Hand Plan Zero) appeared in the loop-gain frequency response when a boost converter operates with continuous inductor current (typically the case), we also call it works in CCM (Continuous Current Mode). For stability, cross over frequency (f_c), unity gain frequency, must lower than this RHPZ frequency.

The fixed parameters for CH3 boost compensation are as follows :

- Transconductance (from FB to COMP), $GM = 200\mu s$
- Feedback voltage, $V_{FB} = FB = 0.8V$

The input parameters for boost compensation are as follows :

- $R_{DS(ON)}$, the NMOSFET $R_{DS(ON)}$, which is use to find transresistance, R_{CS} .
- R1, the voltage divider resistor in between V_{OUT} and FB.
- V_{IN} , input voltage.
- V_{OUT} , desired output voltage
- $I_{OUT(MAX.)}$, maximum output load
- F_{OSC} , operating frequency
- L, inductance
- R_{ESR} , ESR (Equivalent Series Resistance) of C_{OUT} (ceramic output capacitor)
- $T_{DRP}(\%)$, Transient droop.

The results we will get for boost compensation are as follows :

- R_{CS} , the transresistance of current sense.
- R2, the voltage divider resistor in between FB and ground.
- C_F , feedforward capacitor in parallel with R1.
- R_C , compensation resistor on COMP pin.
- C_C , compensation capacitor in series with R_C and connect to ground
- C_P , connect in between COMP pin and ground. (Can be ignored if $C_P < 10pF$)

- C_{OUT} , output capacitance. This compensation is based on ceramic output capacitor.

The major steps for getting above results :

1. $R_{CS} = 2 \times R_{DS(ON)}$

The rest of the steps are the same as sync-boost.

CH4 Asyn-Boost Controller with External MOSFET

CH4 is an asyn-boost controller driving external logic level N type MOSFET, which employs voltage mode control to regulate the output voltage. Compensation depends on designing the loading range working in discontinuous or continuous inductor current mode. (DCM or CCM).

Asyn-Boost in DCM :

We call it DCM because inductor current falls to zero on each switch cycle. The benefit of designing in DCM is the simple loop compensation, which has no RHPZ (Right Hand Plan Zero) and conjugate double pole in the frequency domain to worry about, but has a single load pole instead. However, the output ripple and efficiency are worse than in CCM (Continuous Inductor Current). If the loading is around tens of mA, it is not bad to design in DCM with less impact on the output ripple and efficiency, but gain more easy to stabilize the control loop.

The fixed parameters for CH4 asyn-boost in DCM compensation are as follows:

- Transconductance (from FB to COMP), $GM = 200\mu s$.
- Internal voltage ramp to decide duty cycle, $V_P = 1V$.
- Feedback voltage, $V_{FB} = FB = 1V$

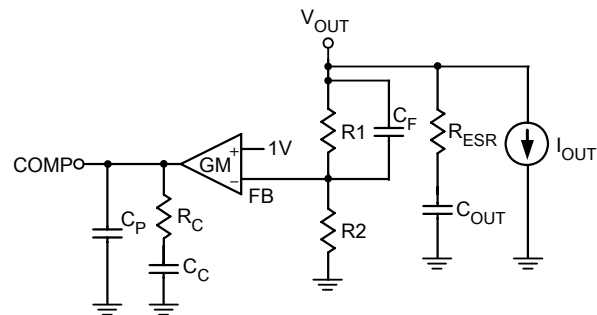

Figure 9

The input parameters for CH4 asyn-boost in DCM compensation are as follows :

- R1, the voltage divider resistor in between V_{OUT} and FB.
- V_{IN}, input voltage.
- V_{OUT}, desired output voltage
- I_{OUT(MAX.)}, maximum output load
- f_{OSC}, operating frequency
- L, inductance
- C_{OUT}, output capacitance. This compensation is based on ceramic output capacitor.
- R_{ESR}, ESR (Equivalent Series Resistance) of C_{OUT} (ceramic output capacitor)

The results we will get for CH4 asyn-boost in DCM compensation are as follows :

- R2, the voltage divider resistor in between FB and ground.
- C_F, feedforward capacitor in parallel with R1.
- R_C, compensation resistor on COMP pin.
- C_C, compensation capacitor in series with R_C and connect to ground
- C_P, connect in between COMP pin and ground. (Can be ignored if C_P < 10pF)

The major steps for getting above results :

1. $R2 = R1 \times \frac{V_{FB}}{V_{OUT} - V_{FB}}$
2. Select suitable inductor to ensure I_{OUT(MIN.)} works in DCM, which is let inductor current falls to zero on each switch cycle.

$$L < \frac{V_{IN} \times D \times (1-D)}{2 \times I_{OUT(MAX.)} \times f_{OSC}}$$

3. Set f_C sufficient below f_{OSC}.

For example: $f_c = \frac{f_{OSC}}{10}$ or lower

4. Find the load pole : $f_{LP} = \frac{2 \times M - 1}{2\pi \times (M - 1) \times R_{LOAD} \times C_{OUT}}$,

$$\text{where } M = \frac{V_{OUT}}{V_{IN}}, R_{LOAD} = \frac{V_{OUT}}{I_{OUT(MAX.)}}$$

5. Get R_C = $\frac{f_c}{f_{LP}} \times V_P$, where $G_{dod} = 2 \times \frac{V_{OUT}}{D} \times \frac{M-1}{2 \times M-1}$,

which is duty to V_{OUT} transfer function.

$$D = \text{duty cycle} = 1 - \frac{V_{IN}}{V_{OUT}}$$

6. Get C_C = C_{OUT} x $\frac{R_{LOAD}}{R_C}$

by letting comp zero = load pole.

7. Find ffz, zero and ffp, pole ratio of voltage divider with C_F.

$$\text{ratio} = \frac{ffp}{ffz} = \frac{V_{OUT}}{V_{FB}}$$

8. Get C_F by placing ffp on f_C and ffz therefore on $\frac{f_c}{\text{ratio}}$.

$$C_F = \frac{1}{2\pi \times ffz \times R1}, \text{ where } ffz = \frac{f_c}{\text{ratio}}$$

9. Evaluate C_P. C_P is for canceling the zero from C_{OUT} (ceramic output capacitor).

$$C_P = C_{OUT} \times \frac{R_{ESR}}{R_C}. C_P \text{ can be ignore if } C_P < 10pF.$$

Asyn-boost in CCM :

We call it CCM because inductor current is always continuous in operation. The benefit of designing in CCM is lower V_{OUT} and inductor current ripple and higher efficiency from the lower coil loss, but with the expense of larger inductor size and cost and the control loop comes with a RHPZ (Right Hand Plan Zero) and a conjugate double pole in the frequency domain to worry about.

The fixed parameters for CH4 asyn-boost in CCM compensation are as follows :

- Transconductance (from FB to COMP), GM = 200us
- Internal voltage ramp to decide duty cycle, V_P = 1V
- Feedback voltage, V_{FB} = FB = 1V

The input parameters for CH4 asyn-boost in CCM compensation are as follows:

- R1, the voltage divider resistor in between V_{OUT} and FB.
- V_{IN}, input voltage.
- V_{OUT}, desired output voltage
- I_{OUT(MAX.)}, maximum output load
- I_{OUT(MIN.)}, minimum output laod
- f_{OSC}, operating frequency

- L, inductance
- C_{OUT}, output capacitance. This compensation is based on ceramic output capacitor.
- R_{ESR}, ESR (Equivalent Series Resistance) of C_{OUT} (ceramic output capacitor)

The results we will get for CH4 asyn-boost in CCM compensation are as follows:

- R₂, the voltage divider resistor in between FB and ground.
- C_F, feedforward capacitor in parallel with R₁.
- R_C, compensation resistor on COMP pin.
- C_C, compensation capacitor in series with R_C and connect to ground
- C_P, connect in between COMP pin and ground. (Can be ignored if C_P < 10pF)

The major steps for getting above results :

1. $R_2 = R_1 \times \frac{V_{FB}}{V_{OUT} - V_{FB}}$
2. Select suitable inductor to ensure I_{OUT(MIN.)} works in CCM,
 $L > \frac{V_{IN} \times D \times (1-D)}{2 \times I_{OUT(MIN.)} \times f_{OSC}}$
3. Find RHPZ(Right Hand Plan Zero) location.

$$RHPZ(Boost) = R_{LOAD} \frac{(1-D)^2}{2\pi L}, \text{ where}$$

$$R_{LOAD} = \frac{V_{OUT}}{I_{OUT(MAX)}}, D = \text{duty cycle} = 1 - \frac{V_{IN}}{V_{OUT}}$$

4. Set f_c (cross over frequency) sufficiently below RHPZ.

For example : $f_c = \frac{RHPZ}{6}$ or lower.

5. Find the load pole : $f_{LP} = \frac{2 \times M - 1}{2\pi \times (M - 1) \times R_{LOAD} \times C_{OUT}}$,

$$\text{where } M = \frac{V_{OUT}}{V_{IN}}, R_{LOAD} = \frac{V_{OUT}}{I_{OUT(MAX)}}.$$

6. Get R_C = $\frac{f_c}{f_{LP}} \times V_P$, where $G_{doc} = \frac{V_{IN}}{(1-D)^2}$,

which is duty to V_{OUT} transfer function.

$$D = \text{duty cycle} = 1 - \frac{V_{IN}}{V_{OUT}}$$

7. Find $f_{cdp} = \frac{1-D}{2\pi \times (LC)^2}$,
- which is the conjugate double pole from LC filter.

8. C_C = $\frac{1}{2\pi \times f_{cdp} \times R_C}$ to cancel one of the double pole.

9. Find C_f by placing its zero on f_{cdp} to cancel another double pole.

$$C_F = \frac{1}{2\pi \times f_{cdp} \times R_1}$$

10. Evaluate C_P. C_P is for canceling the zero from C_{OUT} (ceramic output capacitor).

$$C_P = C_{OUT} \times \frac{R_{ESR}}{R_C}. C_P \text{ can be ignore if } C_P < 10pF.$$

CH5 Asyn-Inverter Controller with External MOSFET

CH5 is an asyn-inverter controller driving external logic level P type MOSFET, which employs voltage mode control to regulate the output voltage. Compensation depends on designing the loading range working in discontinuous or continuous inductor current mode. (DCM or CCM).

Asyn-Inverter in DCM :

We call it DCM because inductor current falls to zero on each switch cycle. The benefit of designing in DCM is the simple loop compensation, which has no RHPZ (Right Hand Plan Zero) and conjugate double pole in the frequency domain to worry about, but has a single load pole instead. However, the output ripple and efficiency are worse than in CCM (Continuous Inductor Current). If the loading is around tens of mA, it is not bad to design in DCM with less impact on the output ripple and efficiency, but gain more easy to stabilize the control loop.

The fixed parameters for CH5 asyn-inverter in DCM compensation are as follows:

- Transconductance (from FB to COMP), GM = 200us
- Internal voltage ramp to decide duty cycle, V_P = 1V
- Feedback voltage, V_{FB} = FB = 0V
- Reference voltage, V_{REF} = 1V

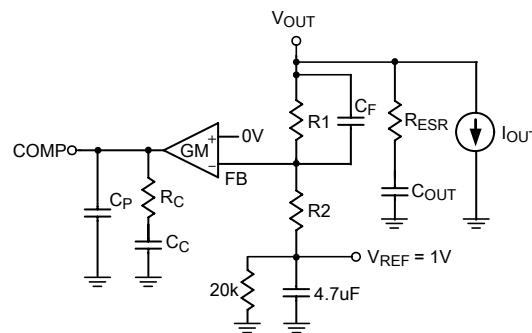

Figure 10

The input parameters for CH5 asyn-inverter in DCM compensation are as follows :

- R1, the voltage divider resistor in between V_{OUT} and FB.
- V_{IN}, input voltage.
- V_{OUT}, desired output voltage
- I_{OUT(MAX.)}, maximum output load
- f_{OSC}, operating frequency
- L, inductance
- C_{OUT}, output capacitance. This compensation is based on ceramic output capacitor.
- R_{ESR}, ESR (Equivalent Series Resistance) of C_{OUT} (ceramic output capacitor)

The results we will get for CH5 asyn-inverter in DCM compensation are as follows :

- R2, the voltage divider resistor in between FB and V_{REF}.
- C_F, feedforward capacitor in parallel with R1.
- R_C, compensation resistor on COMP pin.
- C_C, compensation capacitor in series with R_C and connect to ground
- C_P, connect in between COMP pin and ground. (Can be ignored if C_P < 10pF)

The major steps for getting above results :

1. $R2 = R1 \times \frac{V_{REF} - V_{FB}}{V_{FB} - V_{OUT}}$. If R1 = 1MΩ and V_{OUT} = (-8)V
 then $R2 = 1M \times \frac{1-0}{0-(-8)} = 125k\Omega$

2. Select suitable inductor to ensure I_{OUT(MIN.)} works in DCM, which is let inductor current falls to zero on each switch cycle.

$$L < \frac{V_{IN} \times (1-D)}{2 \times I_{OUT(MAX.)} \times f_{OSC}}$$

3. Set f_C sufficient below f_{OSC}

For example: $f_C = \frac{f_{OSC}}{10}$ or lower

4. Find the load pole : $f_{LP} = \frac{2}{2\pi \times R_{LOAD} \times C_{OUT}}$,

where $R_{LOAD} = \frac{V_{OUT}}{I_{OUT(MAX.)}}$.

5. Get R_C = $\frac{f_C \times V_P}{GM \times G_{dod}}$, where $G_{dod} = \frac{V_{OUT}}{D}$,

which is duty to V_{out} transfer function.

$$D = \text{duty cycle} = \frac{\text{abs}(V_{OUT})}{V_{IN} + \text{abs}(V_{OUT})}$$

6. Get C_C = C_{OUT} x $\frac{R_{LOAD}}{R_C}$

by letting comp zero = load pole.

7. Find ffz, zero and ffp, pole ratio of voltage divider with C_F.

$$\text{ratio} = \frac{ffp}{ffz} = \frac{\text{abs}(V_{OUT}) + V_{REF}}{V_{REF}}$$

8. Get C_F by placing ffp on f_C and ffz therefore on $\frac{f_C}{\text{ratio}}$.

$$C_F = \frac{1}{2\pi \times ffz \times R1}, \text{ where } ffz = \frac{f_C}{\text{ratio}}$$

9. Evaluate C_P. C_P is for canceling the zero from C_{OUT} (ceramic output capacitor).

$$C_P = C_{OUT} \times \frac{R_{ESR}}{R_C}. C_P \text{ can be ignore if } C_P < 10pF.$$

Asyn-Inverter in CCM :

We call it CCM because inductor current is always continuous in operation. The benefit of designing in CCM is lower V_{OUT} and inductor current ripple and higher efficiency from the lower coil loss, but with the expense of larger inductor size and cost and the control loop comes with a RHPZ (Right Hand Plan Zero) and a conjugate double pole in the frequency domain to worry about.

The fixed parameters for CH5 asyn-inverter in CCM compensation are as follows :

- Transconductance (from FB to COMP), GM = 200us
- Internal voltage ramp to decide duty cycle, V_P = 1V
- Feedback voltage, V_{FB} = FB = 0V
- Reference voltage, V_{REF} = 1V

The input parameters for CH5 asyn-inverter in CCM compensation are as follows :

- R1, the voltage divider resistor in between V_{OUT} and FB.
- V_{IN}, input voltage.
- V_{OUT}, desired output voltage
- I_{OUT(MAX.)}, maximum output load

- I_{OUT(MIN.)}, minimum output load
- f_{OSC}, operating frequency
- L, inductance
- C_{OUT}, output capacitance. This compensation is based on ceramic output capacitor.
- R_{ESR}, ESR (Equivalent Series Resistance) of C_{OUT} (ceramic output capacitor)

The results we will get for CH5 asyn-inverter in CCM compensation are as follows :

- R₂, the voltage divider resistor in between FB and V_{REF}.
- C_F, feedforward capacitor in parallel with R₁.
- R_C, compensation resistor on COMP pin.
- C_C, compensation capacitor in series with R_C and connect to ground
- C_P, connect in between COMP pin and ground. (Can be ignored if C_P < 10pF)

The major steps for getting above results :

1. $R_2 = R_1 \times \frac{V_{REF} - V_{FB}}{V_{FB} - V_{OUT}}$. If R₁ = 1MΩ and V_{OUT} = (-8)V
 then $R_2 = 1M \times \frac{1-0}{0-(-8)} = 125k\Omega$

2. Select suitable inductor to ensure I_{OUT(MIN.)} works in CCM,

$$L < \frac{V_{IN} \times (1-D)}{2 \times I_{OUT(MIN.)} \times f_{OSC}}$$

3. Find RHPZ(Right Hand Plan Zero) location.

$$RHPZ(Boost) = R_{LOAD} \frac{(1-D)^2}{2\pi L}, \text{ where}$$

$$R_{LOAD} = \frac{V_{OUT}}{I_{OUT(MAX)}}, D = \text{duty cycle} = \frac{abs(V_{OUT})}{V_{IN} + abs(V_{OUT})}$$

4. Set f_C (cross over frequency) sufficiently below RHPZ.

For example: $f_C = \frac{RHPZ}{6}$ or lower

5. Find the load pole : $f_{LP} = \frac{2}{2\pi \times R_{LOAD} \times C_{OUT}}$,

where $R_{LOAD} = \frac{abs(V_{OUT})}{I_{OUT(MAX.)}}$.

6. Get R_C = $\frac{f_C}{f_{LP}} \times V_P$, where $G_{doc} = \frac{V_{IN}}{(1-D)^2}$,

which is duty to V_{OUT} transfer function.

$$D = \text{duty cycle} = \frac{abs(V_{OUT})}{V_{IN} + abs(V_{OUT})} \times V_{OUT}$$

7. Find $f_{cdp} = \frac{1-D}{2\pi \times (LC)^2}$,

which is the conjugate double pole from LC filter.

8. $C_C = \frac{1}{2\pi \times f_{cdp} \times R_C}$ to cancel one of the double pole.

9. Find C_F by placing its zero on f_{cdp} to cancel another double pole.

$$C_F = \frac{1}{2\pi \times f_{cdp} \times R_1}$$

10. Evaluate C_P. C_P is for canceling the zero from C_{OUT} (ceramic output capacitor).

$$C_P = C_{OUT} \times \frac{R_{ESR}}{R_C}. C_P \text{ can be ignore if } C_P < 10pF.$$

PCB Layout Considerations

- The feedback network should be very close to the FB pin.
- The compensation network should be very close to the COMP pin and avoid through VIA.
- For CH3 current sense, CS should be close to the drain site of external NMOS.
- Keep high current path as short as possible.

Outline Dimension

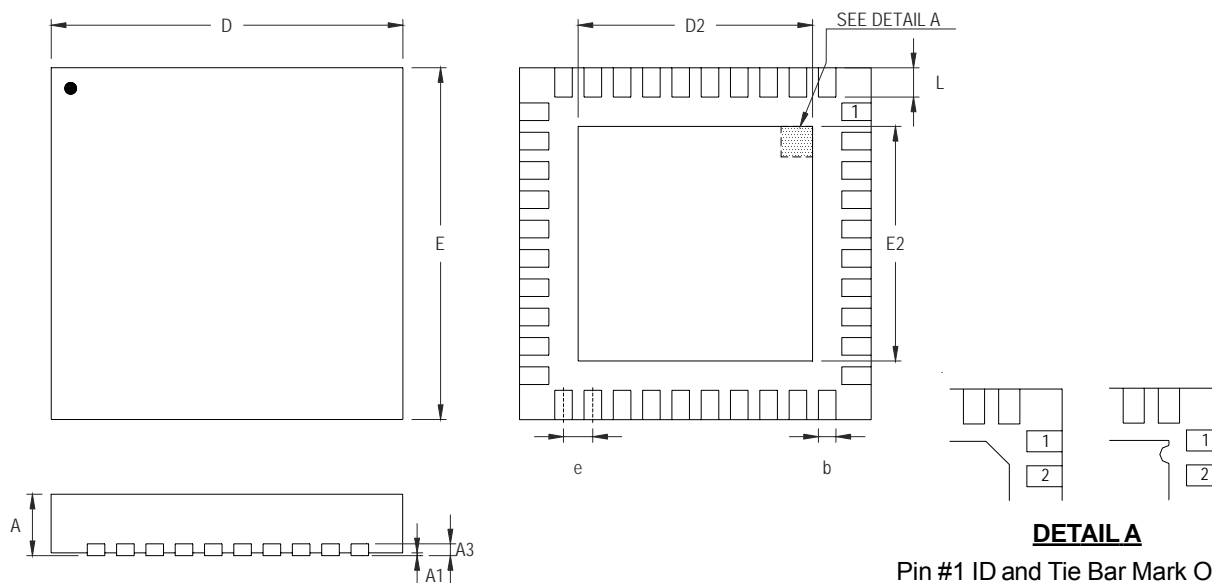

DETAIL A
Pin #1 ID and Tie Bar Mark Options

Note : The configuration of the Pin #1 identifier is optional, but must be located within the zone indicated.

Symbol	Dimensions In Millimeters		Dimensions In Inches	
	Min	Max	Min	Max
A	0.800	1.000	0.031	0.039
A1	0.000	0.050	0.000	0.002
A3	0.175	0.250	0.007	0.010
b	0.180	0.300	0.007	0.012
D	5.950	6.050	0.234	0.238
D2	4.000	4.750	0.157	0.187
E	5.950	6.050	0.234	0.238
E2	4.000	4.750	0.157	0.187
e	0.500		0.020	
L	0.350	0.450	0.014	0.018

V-Type 40L QFN 6x6 Package

Richtek Technology Corporation

Headquarter
5F, No. 20, Taiyuen Street, Chupei City
Hsinchu, Taiwan, R.O.C.
Tel: (8863)5526789 Fax: (8863)5526611

Richtek Technology Corporation

Taipei Office (Marketing)
8F, No. 137, Lane 235, Paochiao Road, Hsintien City
Taipei County, Taiwan, R.O.C.
Tel: (8862)89191466 Fax: (8862)89191465
Email: marketing@richtek.com