

Synchronous Buck PWM DC-DC with Enable & PGOOD

General Description

The RT9209/A is a single power supply PWM DC-DC converter controller designed to drive N-MOSFET in a synchronous buck topology. The IC integrates the control, output adjustment, monitoring and protection functions into a small 8-pin package.

The RT9209/A uses an internal compensated voltage mode PWM control for simple application design. An internal 0.8V reference allows the output voltage to be precisely regulated to low voltage requirement. A fixed 260kHz/400kHz oscillator reduce the component size for saving board area.

The RT9209/A future a enable control pin to shutdown PWM switching and a 90% power good flag indicator. The FB pin under voltage detection function monitor the output short circuit which trigger a three time hiccup sequence to latch off the chip function.

Ordering Information

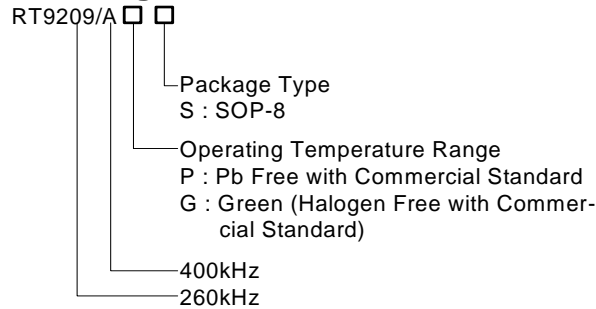

Note :

RichTek Pb-free and Green products are :

- ▶RoHS compliant and compatible with the current requirements of IPC/JEDEC J-STD-020.
- ▶Suitable for use in SnPb or Pb-free soldering processes.
- ▶100%matte tin (Sn) plating.

Features

- Operates at 5V
- 0.8V Internal Reference
- Drives Two N-MOSFET
- Voltage Mode PWM Control
- Fast Transient Response
- Fixed 260kHz/400kHz Oscillator Frequency
- Dynamic 0 to 100% Duty Cycle
- Internal PWM Loop Compensation
- Internal Soft-Start
- Adaptive Non-Overlapping Gate Driver
- Over-Voltage Protection Uses Lower MOSFET
- RoHS Compliant and 100% Lead (Pb)-Free

Applications

- Motherboard Power Regulation for Computers
- Subsystems Power Supplies
- Cable Modems, Set Top Box, and DSL Modems
- DSP and Core Communications processor Supplies
- Memory Power Supplies
- Personal Computer Peripherals
- Industrial Power Supplies
- 5V-Input DC-DC Regulators
- Low Voltage Distributed Power Supplies

Pin Configurations

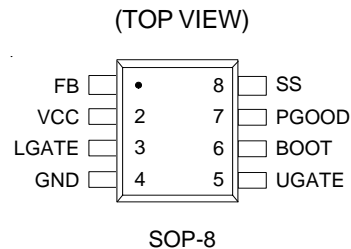

Typical Application Circuit

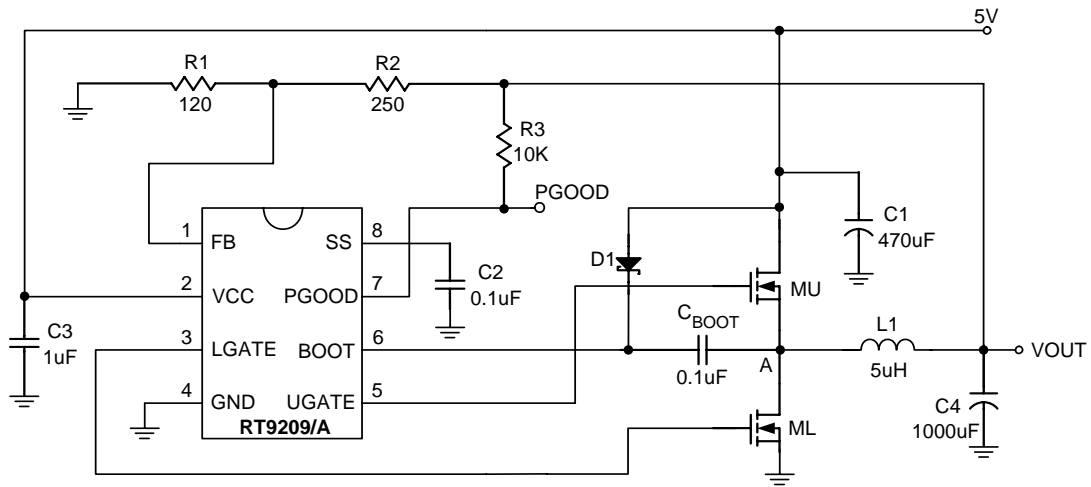

Figure A. RT9209/A Booted from 5V

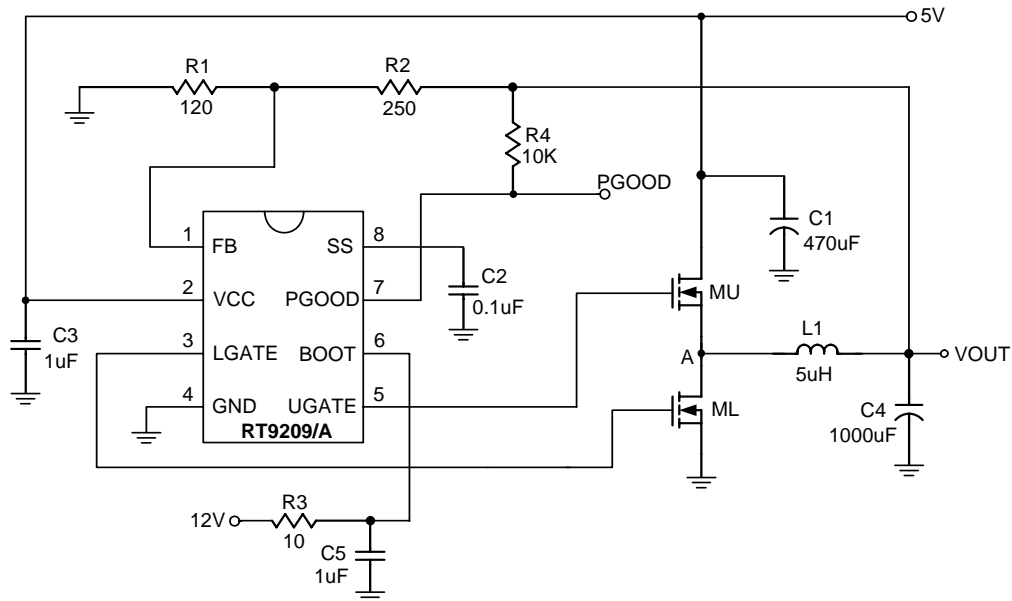
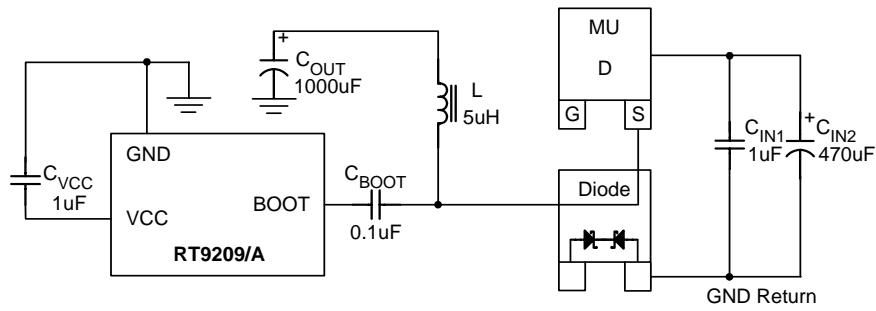

Figure B. RT9209/A Booted from 12V



Layout Placement

Layout Notes

1. Put C_{IN1} & C_{IN2} to be near the MU drain and ML source nodes.
2. Put RT9209/A to be near the C_{OUT}
3. Put C_{BOOT} as close as to BOOT pin
4. Put C_{VCC} as close as to VCC pin

Function Block Diagram

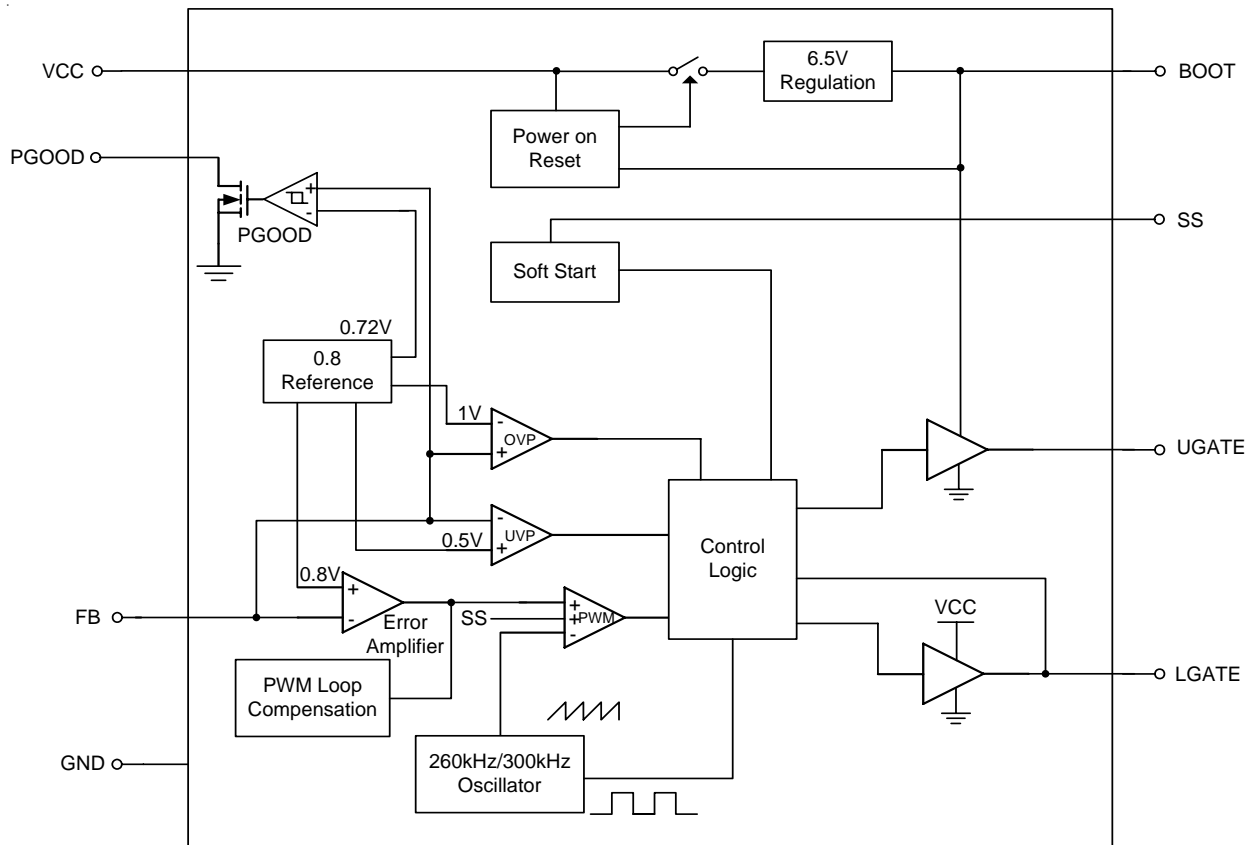

Functional Pin Description

FB (Pin1)

This pin is connected to the PWM converter's output divider. This pin also connects to internal PWM error amplifier inverting input and protection monitor.

VCC (Pin 2)

This is the main bias supply for the RT9209/A. This pin also provides the gate bias charge for the lower MOSFETs gate. The voltage at this pin monitored for power-on reset (POR) purpose. This pin is also the internal 6.5V regulator output powered from BOOT pin when BOOT pin is directly powered from ATX 12V.

LGATE (Pin 3)

Connect LGATE to the PWM converter's lower MOSFET gate. This pin provides the gate drive for the lower MOSFET.

GND (Pin 4)

Signal and power ground for the IC. All voltage levels are measured with respect to this pin.

UGATE (Pin 5)

Connect UGATE pin to the PWM converter's upper MOSFET gate. This pin provides the gate drive for the upper MOSFET.

BOOT (Pin 6)

This pin provides ground referenced bias voltage to the upper MOSFET driver. A bootstrap circuit is used to create a voltage suitable to drive a logic-level N-Channel MOSFET when operating at a single 5V power supply. This pin also could be powered from ATX 12V, in this situation, a internal 6.5V regulator will supply to VCC pin for internal voltage bias.

PGOOD (Pin 7)

PGOOD is an open collector output used to indicate the status of the PWM converter output voltage. This pin is pulled low when the FB is not over 90% of the reference voltage.

SS (Pin 8)

Connect a capacitor from this pin to ground. This capacitor, along with an internal 22 μ A current source, sets the soft-start internal of the synchronous PWM converter.

Absolute Maximum Ratings

- Supply Input Voltage, V_{CC} ----- 7V
- BOOT & UGATE to GND----- 19V
- Input, Output or I/O Voltage ----- GND-0.3V to 7V
- Power Dissipation, P_D @ $T_A = 25^\circ\text{C}$
 - SOP-8 ----- 0.625W
- Package Thermal Resistance
 - SOP-8, θ_{JA} ----- 160 $^\circ\text{C/W}$
- Ambient Temperature Range ----- 0 $^\circ\text{C}$ to +70 $^\circ\text{C}$
- Junction Temperature Range ----- 0 $^\circ\text{C}$ to +125 $^\circ\text{C}$
- Storage Temperature Range ----- -65 $^\circ\text{C}$ to +150 $^\circ\text{C}$
- Lead Temperature (Soldering, 10 sec.) ----- 260 $^\circ\text{C}$

CAUTION:

Stresses beyond the ratings specified in "Absolute Maximum Ratings" may cause permanent damage to the device. This is a stress only rating and operation of the device at these or any other conditions above those indicated in the operational sections of this specification is not implied.

Electrical Characteristics

(V_{CC} = 5V, T_A = 25°C, Unless otherwise specified.)

Parameter	Symbol	Test Conditions	Min	Typ	Max	Units
V_{CC} Supply Current						
Nominal Supply Current	I _{CC}	UGATE, LGATE open	--	3	6	mA
Power-On Reset						
Rising V _{CC} Threshold			3.7	4.1	4.5	V
V _{CC} Threshold Hysteresis			0.3	0.5	0.7	V
Reference						
Reference Voltage			0.784	0.8	0.816	V
Oscillator						
Free Running Frequency	RT9209		210	260	310	kHz
	RT9209A		350	400	450	
Ramp Amplitude	Δ V _{OSC}		--	1.75	--	V _{P-P}
Error Amplifier						
DC gain			33	35	40	dB
PWM Controller Gate Driver						
Upper Drive Source	R _{UGATE}	BOOT = 12V BOOT - V _{UGATE} = 1V	--	7	12	Ω
Upper Drive Sink	R _{UGATE}	V _{UGATE} = 1V	--	7	7.5	Ω
Lower Drive Source	R _{LGATE}	V _{CC} - V _{LGATE} = 1V,	--	7	6	Ω
Lower Drive Sink	R _{LGATE}	V _{LGATE} = 1V	--	3	4	Ω
Protection						
FB Over-Voltage Trip		FB Rising	--	1	--	V
FB Under-Voltage Trip		FB Falling	--	0.6	--	V
Power Good Threshold		FB pin Rising	86	90	95	%
Power Good Hysteresis			--	2	--	%
Power Good Sink Capability		I _{PGOOD} = 1mA	--		0.4	V
SS Source Current			12	20	32	μA

Typical Operating Characteristics

Dead Time

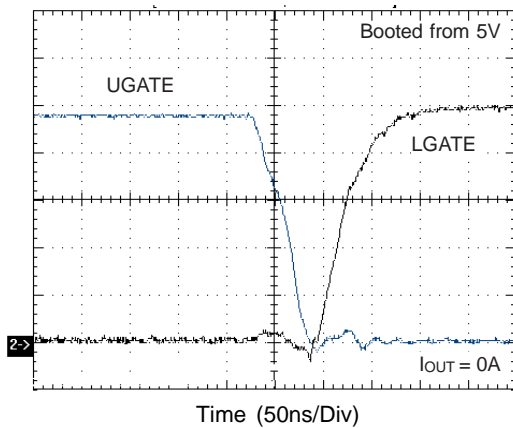

Dead Time

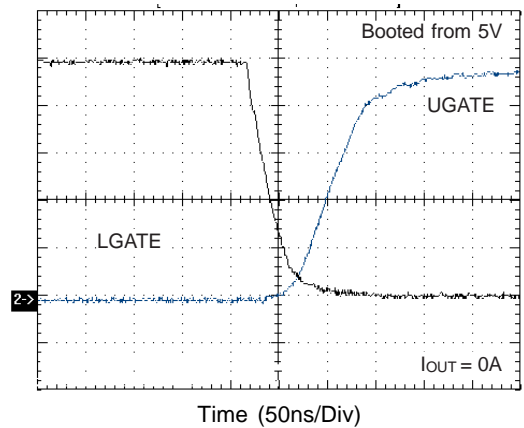

Dead Time

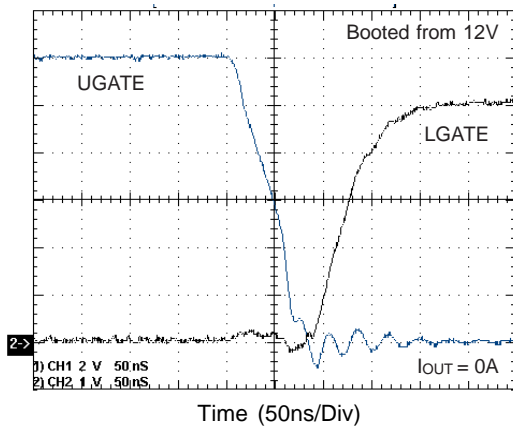

Dead Time

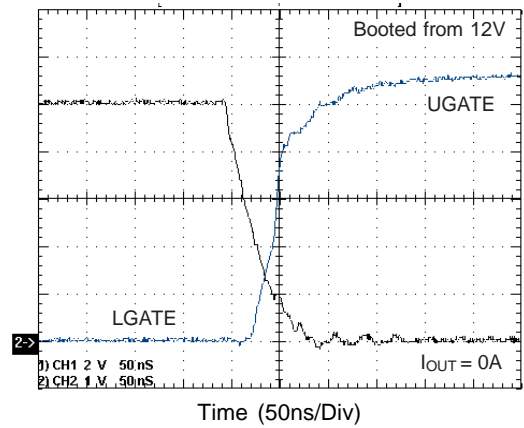

Load Transient

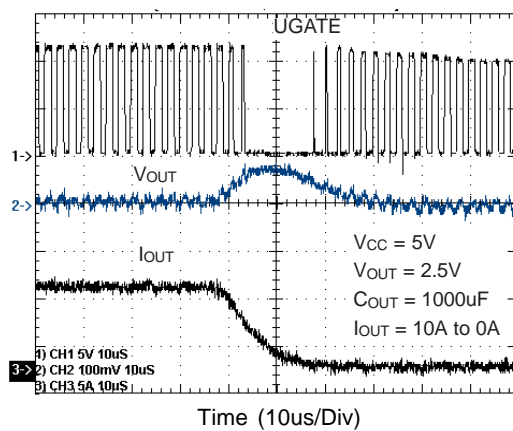

Load Transient

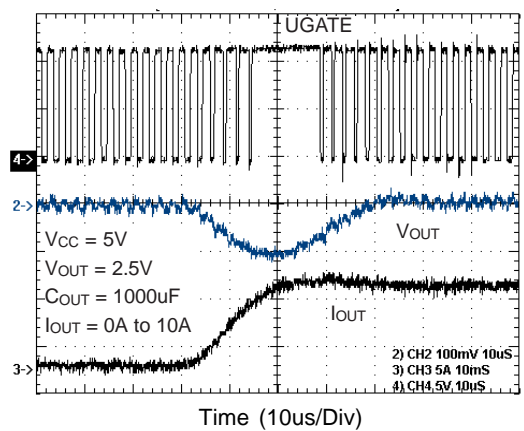

Power On

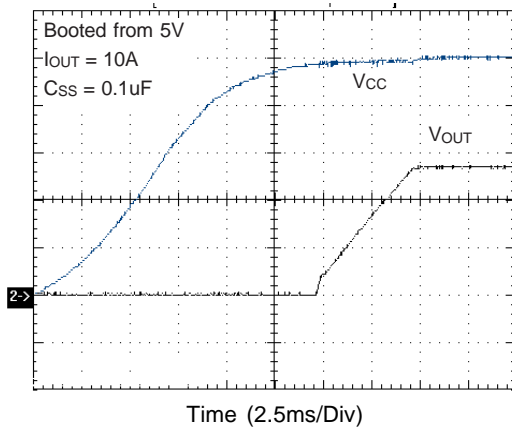

Power Off

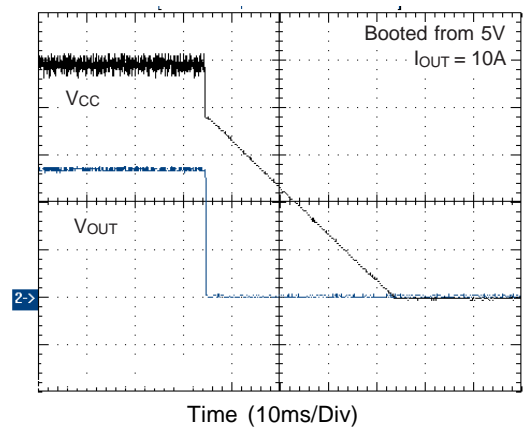

Power On

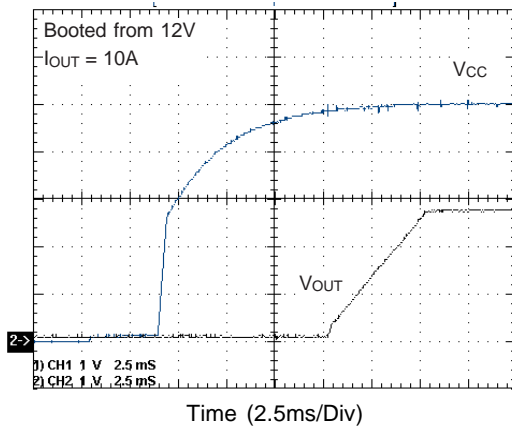

Power Off

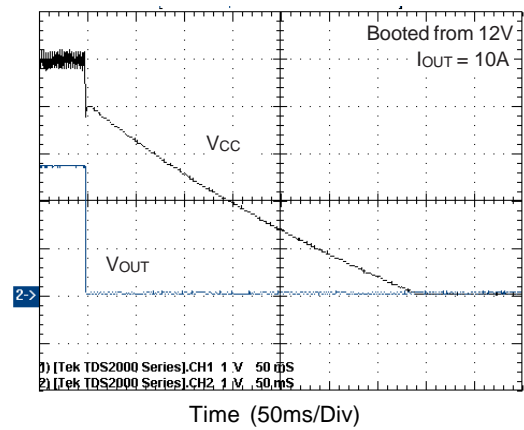

Bootstrap Waveform

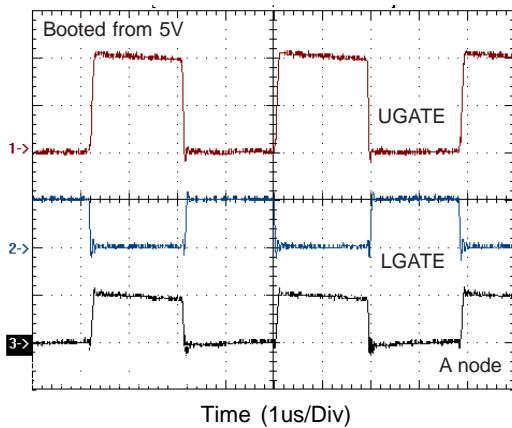

Bootstrap Waveform

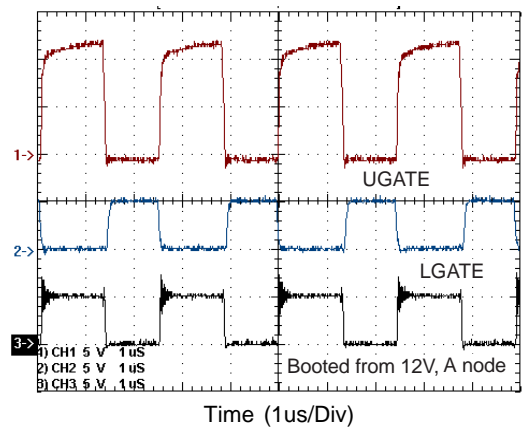

Short Hiccup

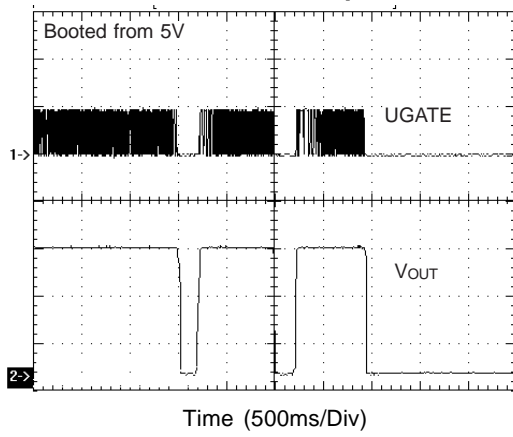

Short Hiccup

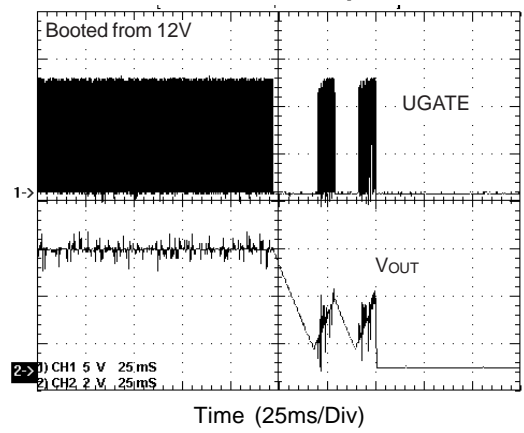

V_{CC} vs. V_{SS}

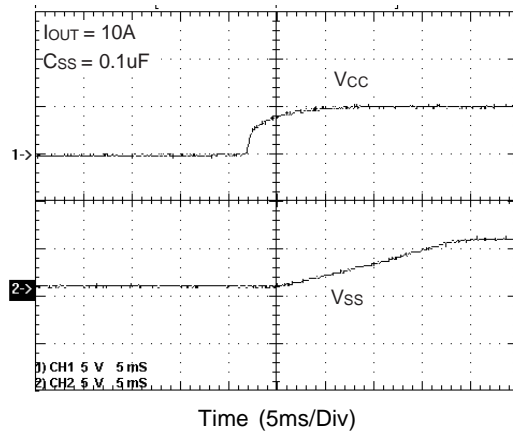

PGOOD vs. V_{OUT}

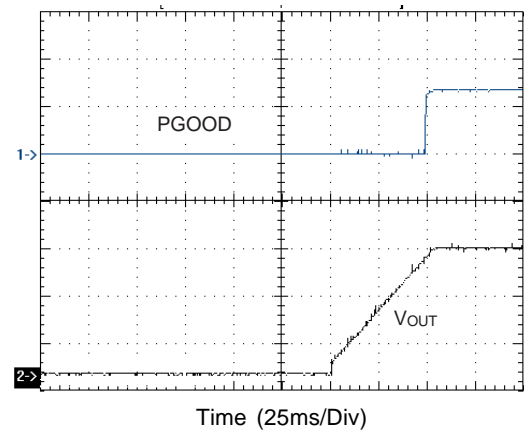

Reference vs. Temperature

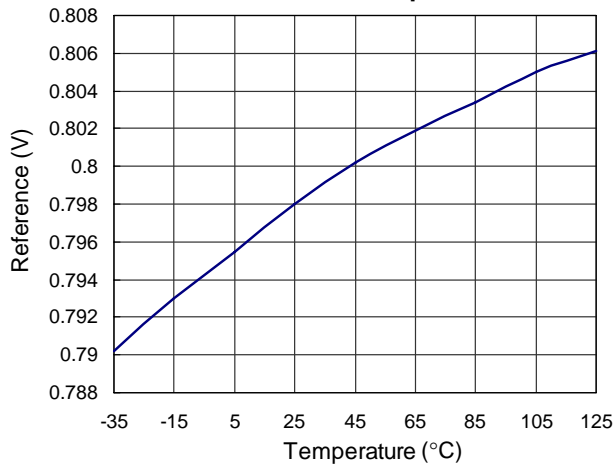

Oscillator Frequency vs. Temperature

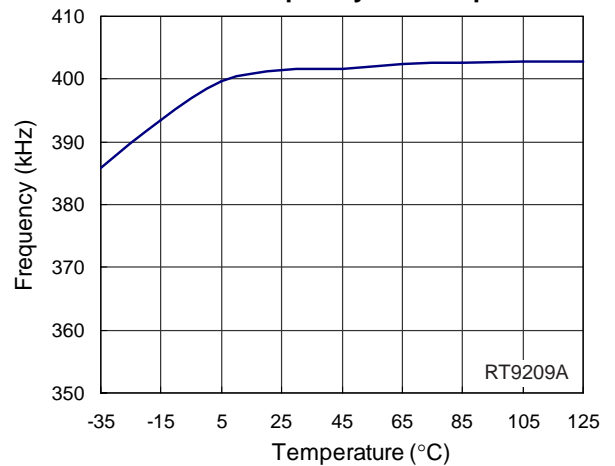

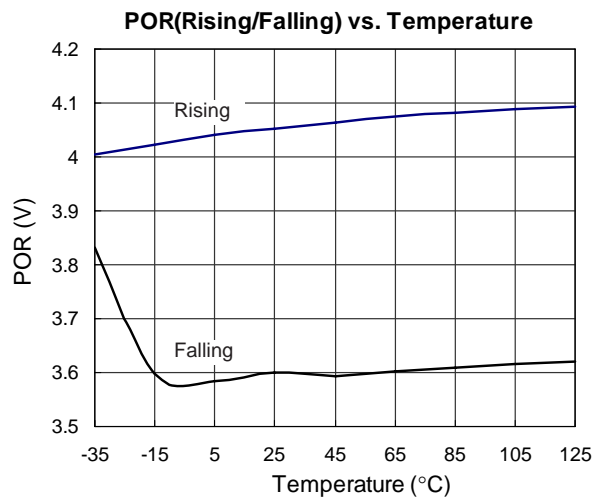

Application Information

The RT9209/A operates at either single 5V power supply with a bootstrap UGATE driver or a 5V/12V dual-power supply form the ATX SMPS. The dual- power supply is recommended for high current applications, the RT9209/A can deliver higher gate driving current while operating with ATX SMPS based on a dual-power supply.

The Bootstrap Operation

In a single power supply system, the UGATE driver of RT9209/A is powered by an external bootstrap circuit, as shown in the Figure1. The boot capacitor, C_{BOOT} , generates a floating reference. Typically a $0.1\mu F$ C_{BOOT} is enough for most of MOSFETs used with the RT9209/A. The voltage drop between BOOT and A node is refreshed to a voltage of $V_{CC} - \text{diode drop } (V_D)$ while the lower MOSFET turning on.

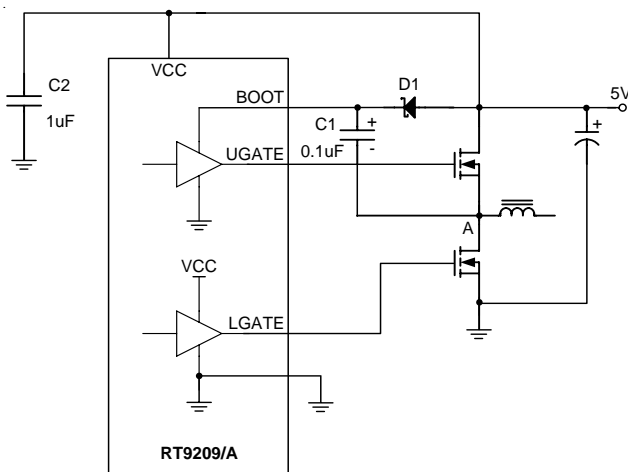

Figure 1. Single 5V power Supply Operation

Dual Power Operation

The RT9209/A is designed to supply a regulated 6.5V at VCC pin automatically when BOOT pin is powered by a 12V. In a system with ATX 5V/12V power supply, the RT9209/A is ideal for higher current applications due to the higher gate driving capability, $V_{UGATE} = 12V$ and $V_{LGATE} = 6.5V$. A RC ($10\Omega/1\mu F$) filter is also recommended at BOOT pin to prevent the ringing induced from fast power-on, as shown in Figure 2.

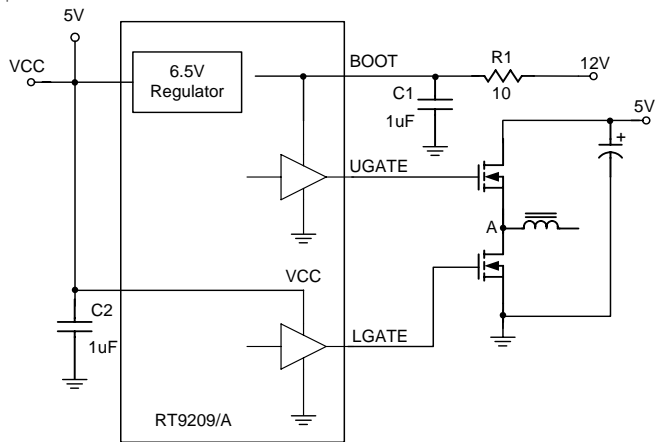

Figure 2. Dual Power Supply Operation

Power On Reset

The Power-On Reset (POR) monitors the supply voltage (normal +5V) at the VCC pin. The VCC POR level is set to 4.1V with 0.5V hysteresis. The POR function initiates soft-start operation after all supply voltages exceed their POR thresholds.

Soft Start

A built-in soft-start is used to prevent surge current from power supply input during power on. The soft-start voltage is controlled by an internal $22\mu A$ to change a capacitor slowly. It clamps the ramping of reference voltage at the input of error amplifier and the pulse-width of the output driver slowly.

Under Voltage and Over Voltage Protection

The voltage at FB pin is monitored and protected against OC (over current), and OV (over voltage). The UV threshold is 0.5V and OV-threshold is 1.0V. Both UV/OV detection have 30ms triggered delay. When OC or UV triggered, a hiccup re-start sequence will be initialized, as shown in Figure 3. Only 3 times of trigger are allowed to latch off. Hiccup is disabled during soft-start interval.

Shutdown

Pulling low the SS pin by a small single transistor can shutdown the RT9209/A PWM controller as shown in typical application circuit.

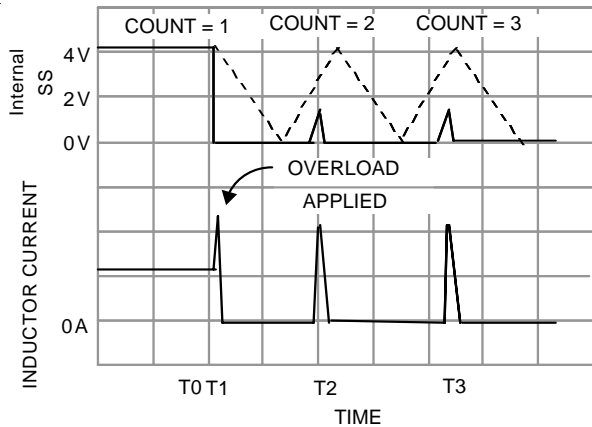

Figure 3

Inductor Selection

The RT9209/A was designed for $V_{IN} = 5V$, step-down application mainly. Figure 4 shows the typical topology and waveforms of step-down converter.

The ripple currents of inductor can be calculated as follows:

$$I_{L RIPPLE} = \frac{(5V - V_{OUT})}{L} \times T_{ON}$$

Because operation frequency is fixed at 260kHz/400kHz,

$$T_{ON} = 3.85 \times \frac{V_{OUT}}{5V}, \text{ or } 2.5 \times \frac{V_{OUT}}{5V}$$

The V_{OUT} ripple is

$$V_{OUT RIPPLE} = I_{L RIPPLE} \times ESR$$

ESR is output capacitor equivalent series resistor

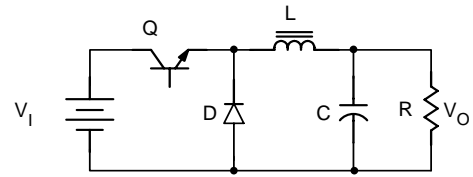

C.C.M.

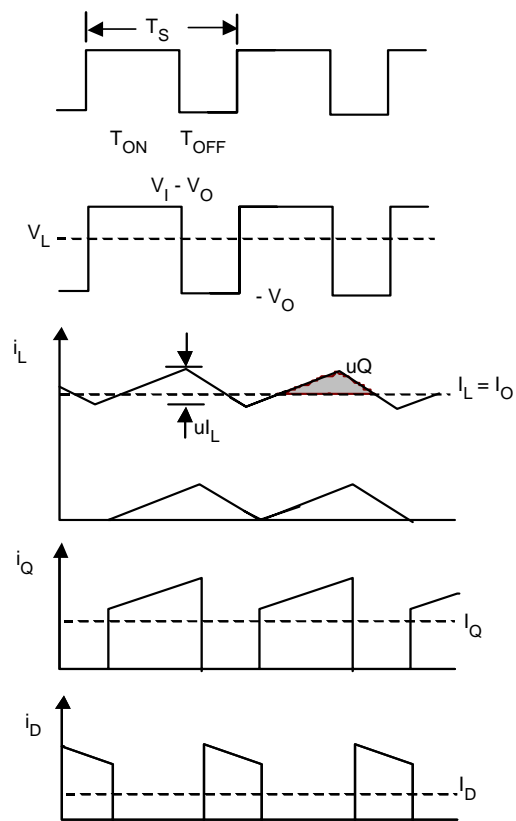

Figure 4

Input / Output Capacitor

High frequency/long life decoupling capacitors should be placed as close to the power pins of the load as physically possible. Be careful not to add inductance to the PCB trace, as it could eliminate the performance from utilizing these low inductance components. Consult with the manufacturer of the load on specific decoupling requirements.

The output capacitors are necessary for filtering output and stabilizing the close loop (see the PWM loop stability). For powering advanced, high-speed processors, it is required to meet with the requirement of fast load transient, high frequency capacitors with low ESR/ESL capacitors are recommended.

Another concern is high ESR induced ripple may trigger UV or OV protections

PWM Loop Stability

The RT9209/A is a voltage mode buck controller designed for 5V step-down applications. The gain of error amplifier is fixed at 35dB for simplified design.

The output amplitude of ramp oscillator is 1.6V, the loop gain and loop pole/zero are calculated as follows :

$$\text{DC loop gain } G_A = 35 \text{ dB} \times \frac{5}{1.6} \times \frac{0.8}{V_{OUT}}$$

$$\text{LC filter pole } P_O = \frac{1}{2} \times \pi \times \sqrt{LC}$$

$$\text{Error Amp pole } P_A = 300\text{kHz}$$

$$\text{ESR zero } Z_O = \frac{1}{2} \times \pi \times \text{ESR} \times C$$

The RT9209/A Bode plot as shown Figure 5 is stable in most of application conditions.

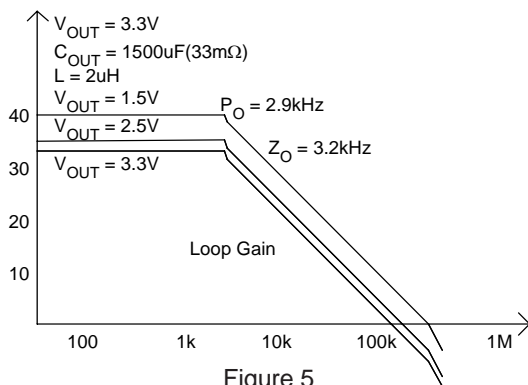

Reference Voltage

Because RT9209/A use a low 35dB gain error amplifier, shown in Figure 6. The voltage regulation is dependent on V_{IN} & V_{OUT} setting. The FB reference voltage of 0.8V were trimmed at $V_{IN} = 5V$ & $V_{OUT} = 2.5V$ condition. In a fixed $V_{IN} = 5V$ application, the FB reference voltage vs. V_{OUT} voltage can be calculated as Figure 7.

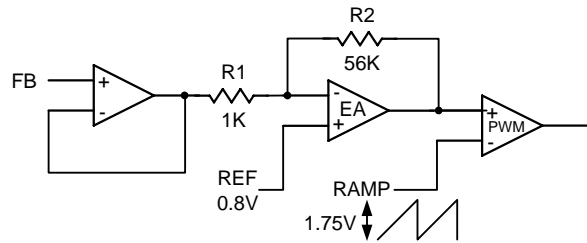

Figure 6

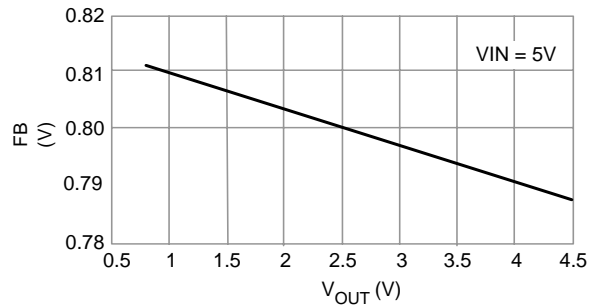

Figure 7

Feedback Divider

The reference of RT9209/A is 0.8V. The output voltage can be set using a resistor based divider as shown in Figure 8. Put the R1 and R2 as close as possible to FB pin and R2 should less than 1 kΩ to avoid noise coupling.

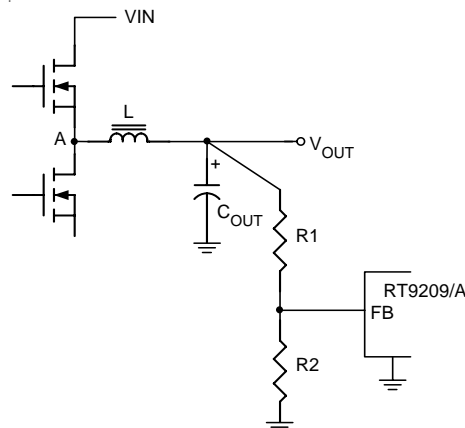

Figure 8

PWM Layout Considerations

MOSFETs switch very fast and efficiently. The speed with which the current transitions from one device to another causes voltage spikes across the interconnecting impedances and parasitic circuit elements. The voltage spikes can degrade efficiency and radiate noise, that results in over-voltage stress on devices. Careful component placement layout and printed circuit design can minimize the voltage spikes induced in the converter. Consider, as an example, the turn-off transition of the upper MOSFET prior to turn-off, the upper MOSFET was carrying the full load current. During turn-off, current stops flowing in the upper MOSFET and is picked up by the low side MOSFET or Schottky diode. Any inductance in the switched current path generates a large voltage spike during the switching interval. Careful component selections, layout of the critical components, and use shorter and wider PCB traces help in minimizing the magnitude of voltage spikes.

There are two sets of critical components in a DC-DC converter using the RT9209/A. The switching power components are most critical because they switch large amounts of energy, and as such, they tend to generate equally large amounts of noise. The critical small signal components are those connected to sensitive nodes or those supplying critical bypass current.

The power components and the PWM controller should be placed firstly. Place the input capacitors, especially the high-frequency ceramic decoupling capacitors, close to the power switches. Place the output inductor and output capacitors between the MOSFETs and the load. Also locate the PWM controller near by MOSFETs.

A multi-layer printed circuit board is recommended. Figure 9 shows the connections of the critical components in the converter. Note that the capacitors C_{IN} and C_{OUT} each of them represents numerous physical capacitors. Use a dedicated grounding plane and use vias to ground all critical components to this layer. Apply another solid layer as a power plane and cut this plane into smaller islands of common voltage levels. The power plane should support the input power and output power nodes. Use the remaining printed circuit layers for small signal routing.

The PCB traces between the PWM controller and the gate of MOSFET and also the traces connecting source of MOSFETs should be sized to carry 2A peak currents.

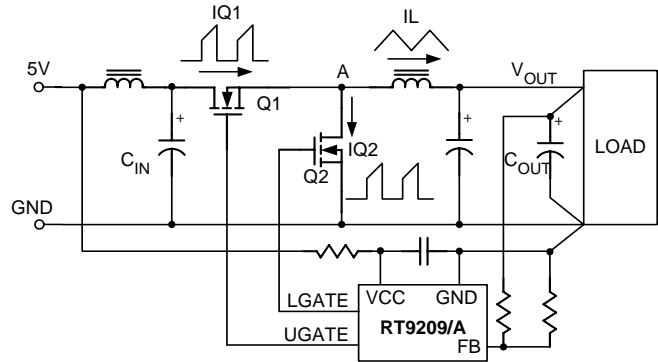
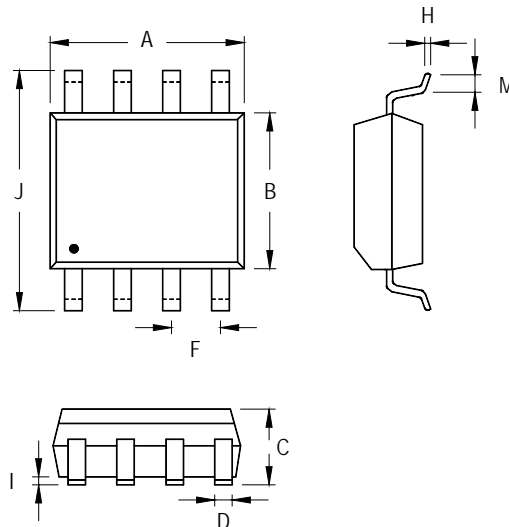

Figure 9

Outline Dimension



Symbol	Dimensions In Millimeters		Dimensions In Inches	
	Min	Max	Min	Max
A	4.801	5.004	0.189	0.197
B	3.810	3.988	0.150	0.157
C	1.346	1.753	0.053	0.069
D	0.330	0.508	0.013	0.020
F	1.194	1.346	0.047	0.053
H	0.170	0.254	0.007	0.010
I	0.050	0.254	0.002	0.010
J	5.791	6.200	0.228	0.244
M	0.400	1.270	0.016	0.050

8-Lead SOP Plastic Package

Richtek Technology Corporation

Headquarter
 5F, No. 20, Taiyuen Street, Chupei City
 Hsinchu, Taiwan, R.O.C.
 Tel: (8863)5526789 Fax: (8863)5526611

Richtek Technology Corporation

Taipei Office (Marketing)
 8F, No. 137, Lane 235, Paochiao Road, Hsintien City
 Taipei County, Taiwan, R.O.C.
 Tel: (8862)89191466 Fax: (8862)89191465
 Email: marketing@richtek.com