



# NEC's 13 GHz INPUT DIVIDE BY 8 PRESCALER IC FOR SATELLITE COMMUNICATIONS

## UPB1512TU

### FEATURES

- **OPERATING FREQUENCY:**  
f<sub>in</sub> = 5 to 13 GHz
- **LOW CURRENT CONSUMPTION:**  
I<sub>CC</sub> = 48 mA @ V<sub>CC</sub> = 5.0 V
- **HIGH-DENSITY SURFACE MOUNTING:**  
8-pin lead-less minimold
- **SUPPLY VOLTAGE:**  
V<sub>CC</sub> = 4.5 to 5.5 V
- **DIVISION RATIO:**  
8

### DESCRIPTION

NEC's UPB1512TU is a silicon germanium (SiGe) monolithic integrated circuit designed as a divide by 8 prescaler IC for satellite communications and point-to-point/multi-point radios.

The package is 8-pin lead-less minimold suitable for surface mount.

This IC is manufactured using our 50 GHz f<sub>max</sub> UHS2 (Ultra High Speed Process) silicon bipolar process.

### APPLICATIONS

- POINT-TO-POINT/ MULTI-POINT RADIOS
- VSAT RADIOS

### ORDERING INFORMATION

PART NUMBER	ORDER NUMBER	PACKAGE	MARKING	SUPPLYING FORM
UPB1512TU-E2	UPB1512TU-E2-A	8-pin lead-less minimold (Pb-Free) <b>Note</b>	1512	<ul style="list-style-type: none"> <li>• 8 mm wide embossed taping</li> <li>• Pin 5, 6, 7, 8 indicates pull-out direction of tape</li> <li>• Qty 5 kpcs/reel</li> </ul>

**Note** With regards to terminal solder (the solder contains lead) plated products (conventionally plated), contact your nearby sales office.

**Remark** To order evaluation samples, contact your nearby sales office.  
Part number for sample order: UPB1512TU

**INTERNAL BLOCK DIAGRAM AND PIN CONNECTIONS**

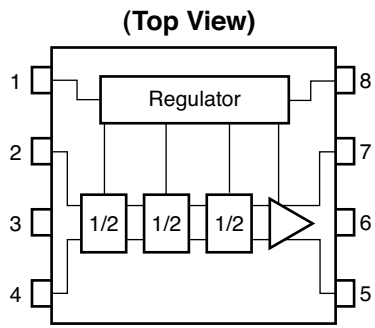

PIN NO.	PIN NAME
1	V <sub>cc1</sub>
2	IN
3	GND
4	$\overline{\text{IN}}$
5	$\overline{\text{OUT}}$
6	GND
7	OUT
8	V <sub>cc2</sub>

**SYSTEM APPLICATION EXAMPLE**

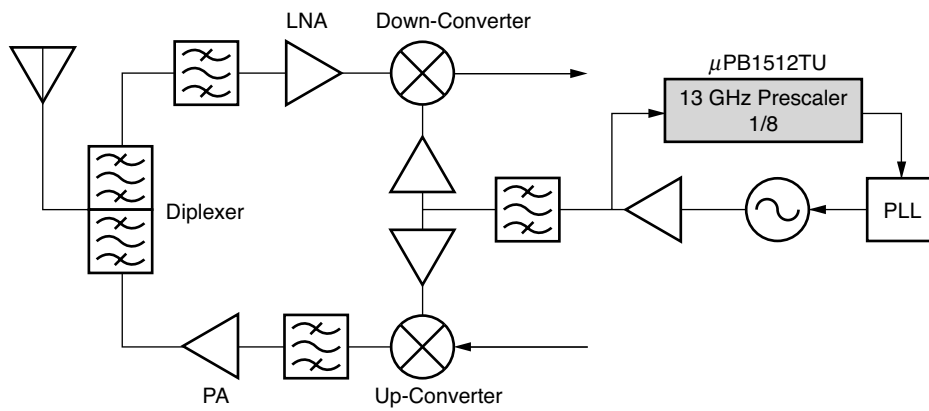

## PIN EXPLANATION

PIN NO.	PIN NAME	APPLIED VOLTAGE (V)	FUNCTION AND APPLICATIONS
1	V <sub>cc1</sub>	5	Power supply pin. This pin must be equipped with bypass capacitor (example : 100 pF and 10 nF) to minimize ground impedance.
2	IN	-	Signal input pin. This pin should be coupled to signal source with capacitor (example : 100 pF) for DC cut.
3	GND	0	Ground pin. Ground pattern on the board should be formed as widely as possible to minimize ground impedance.
4	$\overline{\text{IN}}$	-	Signal input bypass pin. This pin must be equipped with bypass capacitor (example : 100 pF) to minimize ground impedance.
5	$\overline{\text{OUT}}$	-	Divided frequency output pin. This pin should be coupled to load device with capacitor (example : 100 pF) for DC cut.
6	GND	0	Ground pin. Ground pattern on the board should be formed as widely as possible to minimize ground impedance.
7	OUT	-	Divided frequency output pin. This pin should be coupled to load device with capacitor (example : 100 pF) for DC cut.
8	V <sub>cc2</sub>	5	Power supply pin. This pin must be equipped with bypass capacitor (example : 100 pF and 10 nF) to minimize ground impedance.

**ABSOLUTE MAXIMUM RATINGS**

PARAMETER	SYMBOL	TEST CONDITIONS	RATINGS	UNIT
Supply Voltage	V <sub>CC</sub>	T <sub>A</sub> = +25°C	6	V
Total Power Dissipation	P <sub>D</sub>	T <sub>A</sub> = +85°C <b>Note</b>	867	mW
Thermal Resistance (junction to ground paddle)	R <sub>th(j-c)</sub>	T <sub>A</sub> = +85°C <b>Note</b>	75	°C/W
Operating Ambient Temperature	T <sub>A</sub>		-40 to +85	°C
Storage Temperature	T <sub>stg</sub>		-55 to +150	°C

**Note** Mounted on 33 × 21 × 0.4 mm polyimide PCB, with copper patterning on both sides.

**RECOMMENDED OPERATING RANGE**

PARAMETER	SYMBOL	MIN.	TYP.	MAX.	UNIT
Supply Voltage	V <sub>CC</sub>	4.5	5.0	5.5	V
Operating Ambient Temperature	T <sub>A</sub>	-40	+25	+85	°C

**ELECTRICAL CHARACTERISTICS** (V<sub>CC</sub> = 4.5 to 5.5 V, T<sub>A</sub> = -40 to +85°C, Z<sub>s</sub> = Z<sub>L</sub> = 50 Ω)

PARAMETER	SYMBOL	TEST CONDITIONS	MIN.	TYP.	MAX.	UNIT
Circuit Current	I <sub>CC</sub>	No Signals	-	48	75	mA
Input Sensitivity	P <sub>in1</sub>	f <sub>in</sub> = 5 to 6 GHz	-8	-	-5	dBm
	P <sub>in2</sub>	f <sub>in</sub> = 6 to 12 GHz	-8	-	0	dBm
	P <sub>in3</sub>	f <sub>in</sub> = 12 to 13 GHz	-5	-	0	dBm
Output Power	P <sub>out</sub>	f <sub>in</sub> = 5 to 13 GHz, single ended, P <sub>in</sub> = -5 dBm	-11	-4.5	2	dBm

**TYPICAL CHARACTERISTICS** ( $T_A = +25^\circ\text{C}$ , unless otherwise specified)

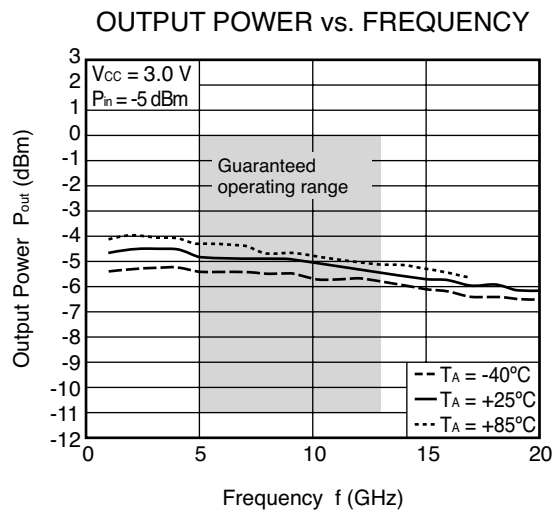
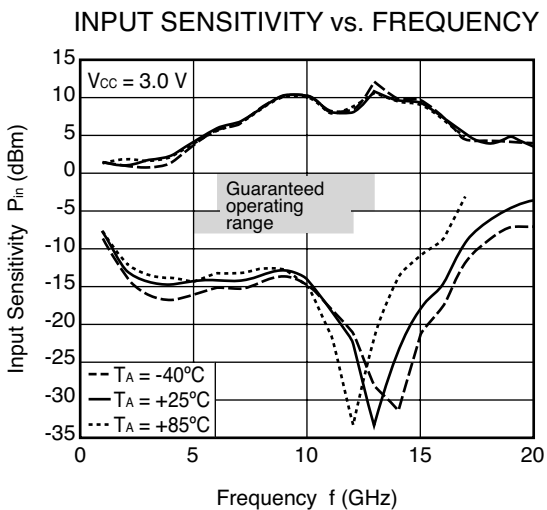
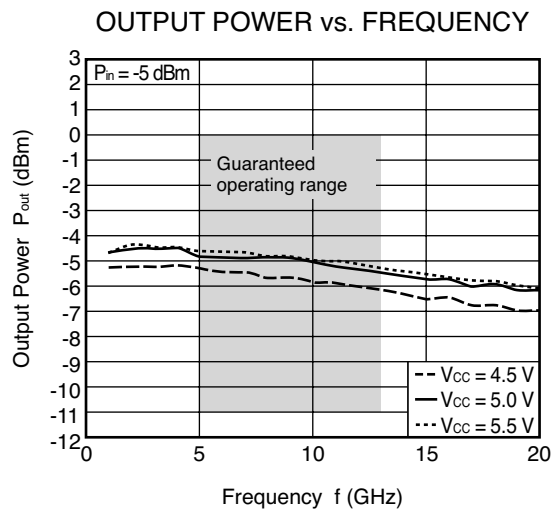
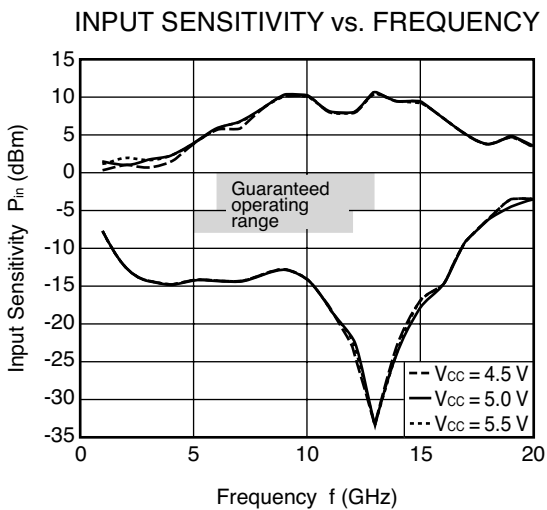

**Remark** The graphs indicate nominal characteristics.

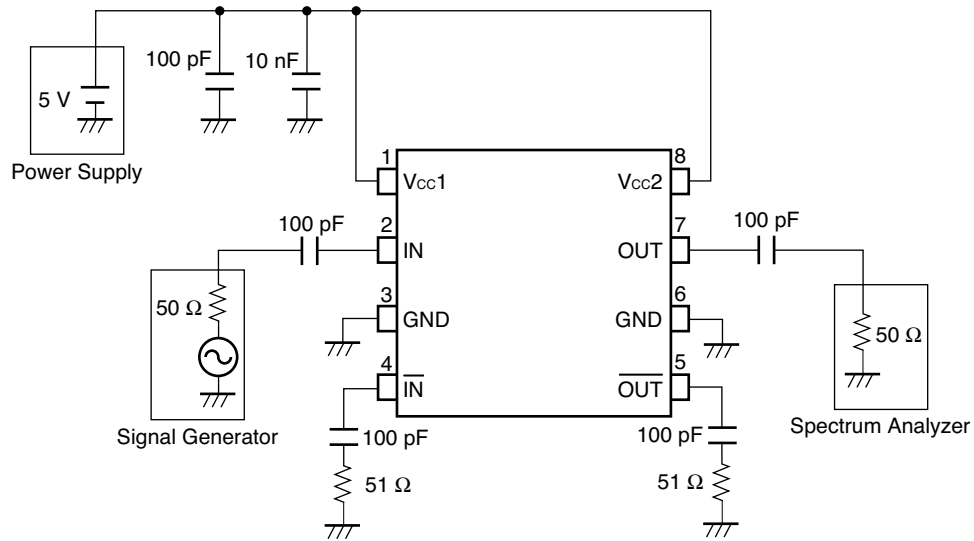

MEASUREMENT CIRCUITS

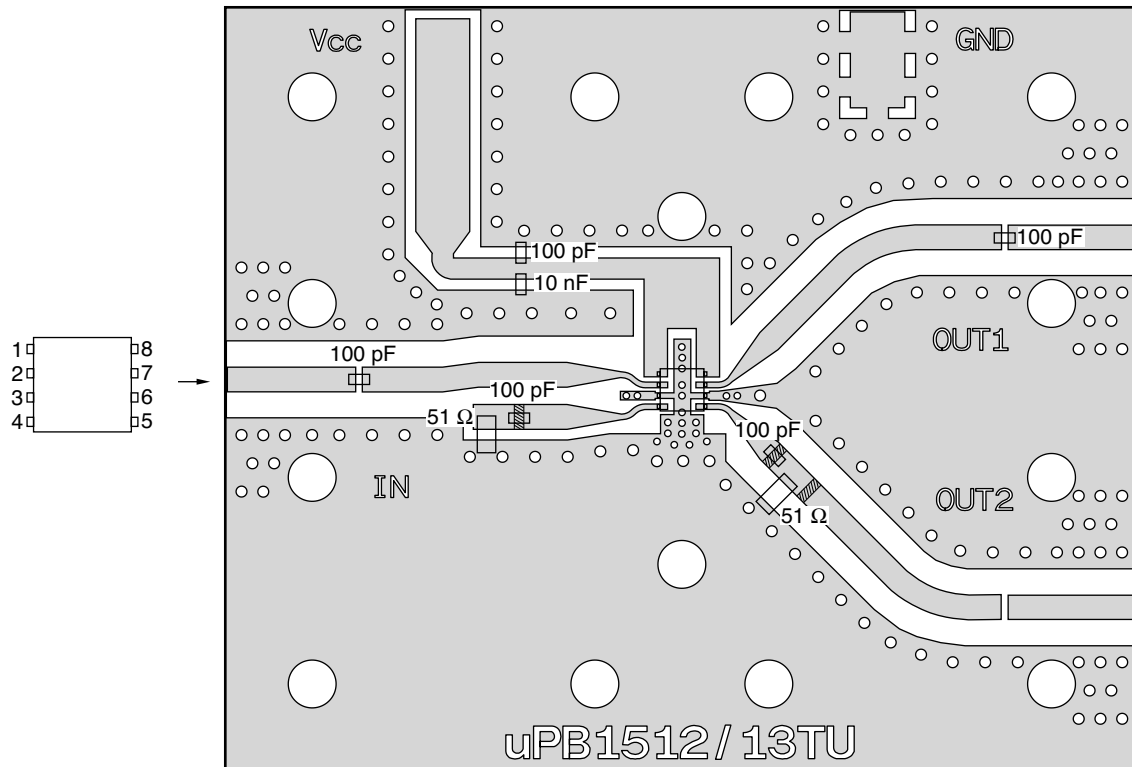

The application circuits and their parameters are for reference only and are not intended for actual design-ins.

## ILLUSTRATION OF THE MEASUREMENT CIRCUIT ASSEMBLED ON EVALUATION BOARD



- Remarks**
1. 33 × 21 × 0.4 mm double-sided copper-clad polyimide PCB
  2. Back side: GND pattern
  3. Solder plated on pattern
  4.  represents cutout
  5. : Through holes





**NOTES ON CORRECT USE**

- (1) Observe precautions for handling because of electro-static sensitive devices.
- (2) Form a ground pattern as widely as possible to minimize ground impedance (to prevent undesired oscillation).
- (3) Keep the track length of the ground terminals as short as possible.
- (4) Bypass capacitance must be attached to V<sub>CC</sub> line.
- (5) Exposed heat sink at bottom on package must be soldered to PCB RF/DC ground.

**RECOMMENDED SOLDERING CONDITIONS**

This product should be soldered and mounted under the following recommended conditions. For soldering methods and conditions other than those recommended below, contact your nearby sales office.

Soldering Method	Soldering Conditions	Condition Symbol
Infrared Reflow	Peak temperature (package surface temperature) : 260°C or below Time at peak temperature : 10 seconds or less Time at temperature of 220°C or higher : 60 seconds or less Preheating time at 120 to 180°C : 120±30 seconds Maximum number of reflow processes : 3 times Maximum chlorine content of rosin flux (% mass) : 0.2%(Wt.) or below	IR260
Wave Soldering	Peak temperature (molten solder temperature) : 260°C or below Time at peak temperature : 10 seconds or less Preheating temperature (package surface temperature) : 120°C or below Maximum number of flow processes : 1 time Maximum chlorine content of rosin flux (% mass) : 0.2%(Wt.) or below	WS260
Partial Heating	Peak temperature (terminal temperature) : 350°C or below Soldering time (per side of device) : 3 seconds or less Maximum chlorine content of rosin flux (% mass) : 0.2%(Wt.) or below	HS350

**Caution Do not use different soldering methods together (except for partial heating).**

Life Support Applications

These NEC products are not intended for use in life support devices, appliances, or systems where the malfunction of these products can reasonably be expected to result in personal injury. The customers of CEL using or selling these products for use in such applications do so at their own risk and agree to fully indemnify CEL for all damages resulting from such improper use or sale.

**CEL** California Eastern Laboratories, Your source for NEC RF, Microwave, Optoelectronic, and Fiber Optic Semiconductor Devices.  
 4590 Patrick Henry Drive • Santa Clara, CA 95054-1817 • (408) 988-3500 • FAX (408) 988-0279 • [www.cel.com](http://www.cel.com)

DATA SUBJECT TO CHANGE WITHOUT NOTICE

01/17/05

Subject: Compliance with EU Directives

CEL certifies, to its knowledge, that semiconductor and laser products detailed below are compliant with the requirements of European Union (EU) Directive 2002/95/EC Restriction on Use of Hazardous Substances in electrical and electronic equipment (RoHS) and the requirements of EU Directive 2003/11/EC Restriction on Penta and Octa BDE.

CEL Pb-free products have the same base part number with a suffix added. The suffix –A indicates that the device is Pb-free. The –AZ suffix is used to designate devices containing Pb which are exempted from the requirement of RoHS directive (\*). In all cases the devices have Pb-free terminals. All devices with these suffixes meet the requirements of the RoHS directive.

This status is based on CEL’s understanding of the EU Directives and knowledge of the materials that go into its products as of the date of disclosure of this information.

Restricted Substance per RoHS	Concentration Limit per RoHS (values are not yet fixed)	Concentration contained in CEL devices	
		-A	-AZ
Lead (Pb)	< 1000 PPM	Not Detected	(*)
Mercury	< 1000 PPM	Not Detected	
Cadmium	< 100 PPM	Not Detected	
Hexavalent Chromium	< 1000 PPM	Not Detected	
PBB	< 1000 PPM	Not Detected	
PBDE	< 1000 PPM	Not Detected	

If you should have any additional questions regarding our devices and compliance to environmental standards, please do not hesitate to contact your local representative.

Important Information and Disclaimer: Information provided by CEL on its website or in other communications concerning the substance content of its products represents knowledge and belief as of the date that it is provided. CEL bases its knowledge and belief on information provided by third parties and makes no representation or warranty as to the accuracy of such information. Efforts are underway to better integrate information from third parties. CEL has taken and continues to take reasonable steps to provide representative and accurate information but may not have conducted destructive testing or chemical analysis on incoming materials and chemicals. CEL and CEL suppliers consider certain information to be proprietary, and thus CAS numbers and other limited information may not be available for release.

In no event shall CEL’s liability arising out of such information exceed the total purchase price of the CEL part(s) at issue sold by CEL to customer on an annual basis.

See CEL Terms and Conditions for additional clarification of warranties and liability.