

General Description

The AAT3686 BatteryManager is a highly integrated single-cell lithium-ion/polymer battery charger IC designed to operate with USB port and AC adapter inputs. It requires the minimum number of external components.

The AAT3686 precisely regulates battery charge voltage and current for 4.2V lithium-ion/polymer battery cells. Adapter charge current rates can be programmed up to 1.5A. In the absence of an adapter and with a USB port connected, the battery can also be charged by USB power. Depending on the USB port type, the AAT3686 charge current can be programmed for two separate levels up to 500mA. An optional Charge Reduction Loop is also built in to allow users to charge the battery with available current from a USB port, while keeping the port voltage regulated. USB charging is disabled when an adapter is present.

Battery temperature and charge state are fully monitored for fault conditions. In the event of an over-voltage or over-temperature failure, the device will automatically shut down, thus protecting the charging device, control system, and the battery under charge. Status monitor output pins are provided to indicate the battery charge status by directly driving two external LEDs. A serial interface output is available to report 22 various status states to a microcontroller.

The AAT3686 is available in a Pb-free, thermally-enhanced, space-saving TDFN34-16 (3x4mm) or TDFN44-16 (4x4mm) package and is rated over the -40°C to +85°C temperature range.

Features

- USB Port/AC Adapter System Power Charger
 - USB: Programmable to 500mA for USB Hi/Lo
 - Adapter: Programmable to 1.5A Max
- 4.0V to 5.5V Input Voltage Range
- Adapter Present Indicator (ADPP# Pin)
- Adapter Presence Automatically Disables USB Charging
- High Level of Integration With Internal:
 - Charging Devices
 - Reverse Blocking Diodes
 - Current Sensing
- Automatic Recharge Sequencing
- Digital Thermal Regulation in ADP Charge
- Charge Reduction Loop in USB Charge
- Battery Temperature Monitoring
- Full Battery Charge Auto Turn-Off
- Over-Voltage and Emergency Thermal Protection
- Power On Reset and Soft Start
- Serial Interface Status Reporting
- TDFN34-16 or TDFN44-16 Package

Applications

- Cellular Telephones
- Digital Still Cameras
- Hand-Held PCs
- MP3 Players
- Personal Data Assistants (PDAs)
- Other Lithium-Ion/Polymer Battery-Powered Devices

Typical Application

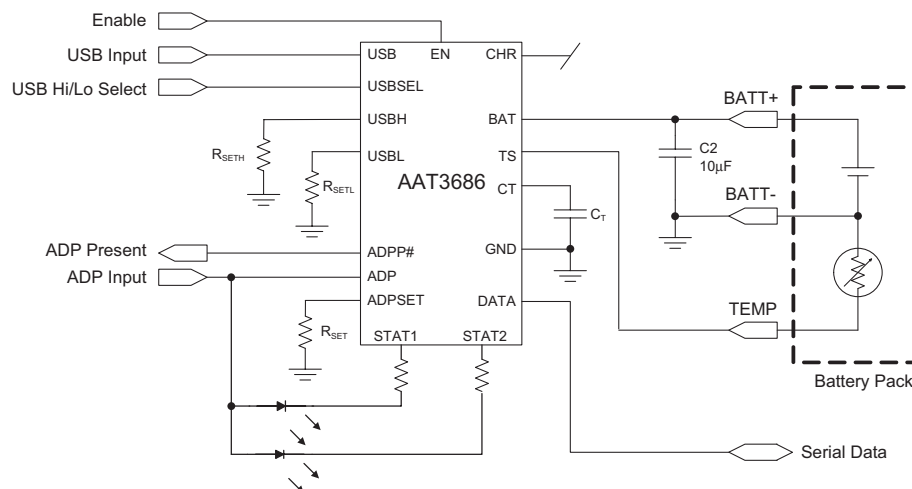

Pin Descriptions

Pin # (TDFN34-16/ TDFN44-16)	Name	Type	Function
1	USB	In	USB power supply input.
2	BAT	In/Out	Battery charging and sensing.
3	ADP	In	Adapter input.
4	GND	Ground	Ground connection.
5	CHR	In/Out	Resistor divider to set USB voltage regulation for charge reduction mode. Leave this pin open for default 4.5V USB regulation point. Tie to USB pin to disable this function.
6	EN	In	Enable pin. Logic high enables the IC.
7	ADPP#	Out	Adapter present indicator. This pin is open drain until ADP pin reaches threshold
8	TS	In/Out	Connect to 10kΩ NTC thermistor.
9	DATA	In/Out	Status report to microcontroller via serial interface, open-drain.
10	STAT2	Out	Battery charge status indicator pin to drive an LED: active low, open-drain.
11	STAT1	Out	Battery charge status indicator pin to drive an LED: active low, open-drain.
12	CT	In/Out	Timing capacitor to adjust internal watchdog timer. Set maximum charge time for adapter powered trickle, CC, and CV charge modes. The watchdog timer only sets the timers for adapter battery charging; there is no timeout for the battery charging from the USB input. If timing function is not needed, terminate this pin to ground.
13	USBSEL	In	When USB is present, use this pin to toggle between 100mA and 500mA limit.
14	USBL	In/Out	Connect resistor here to set charge current for low-current USB port.
15	USBH	In/Out	Connect resistor here to set charge current for high-current USB port.
16	ADPSET	In/Out	Use resistor at this pin to set adapter charging current.
EP			Exposed paddle (bottom); connect to GND directly beneath package.

Pin Configuration

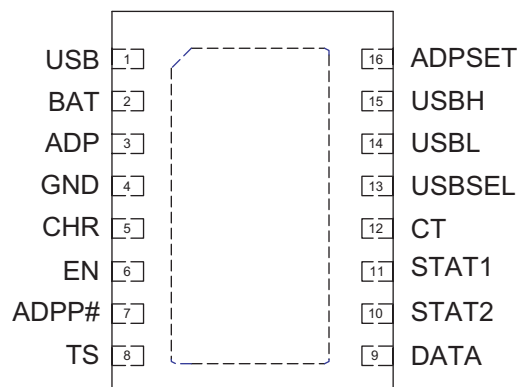
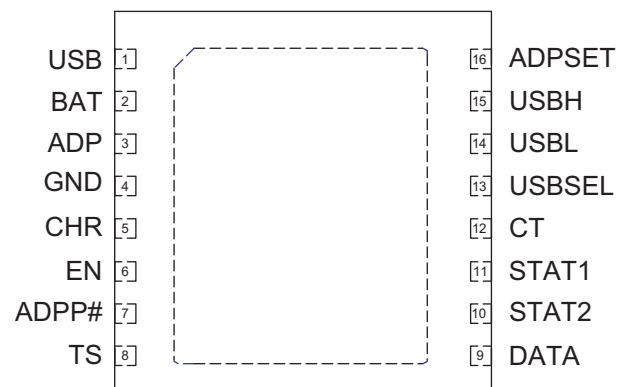
**TDFN34-16
(Top View)**

**TDFN44-16
(Top View)**

AAT3686 Feature Options

Product	Internal Pull-Up Resistor on EN Pin	Can Leave TS Pin Open	Battery Recharge Voltage Active
AAT3686	No	No	Always active
AAT3686-1	Yes	Yes	Always active
AAT3686-3	No	No	Active only after charge complete

Absolute Maximum Ratings¹

Symbol	Description	Value	Units
V _P	USB, ADP Input Voltage, <30ms, Duty Cycle <10%	-0.3 to 7.0	V
V _P	USB, ADP Input Voltage, Continuous	-0.3 to 6.0	V
V _N	BAT, USBSEL, USBH, USBL, ADPSET, STAT1, STAT2, ADPP#, DATA, TS, CT, CHR, EN	-0.3 to V _P + 0.3	V
T _J	Operating Junction Temperature Range	-40 to 150	°C
T _{LEAD}	Maximum Soldering Temperature (at leads)	300	°C

Thermal Information²

Symbol	Description	Value	Units
θ _{JA}	Maximum Thermal Resistance	37	°C/W
P _D	Maximum Power Dissipation	2.7	W

1. Stresses above those listed in Absolute Maximum Ratings may cause permanent damage to the device. Functional operation at conditions other than the operating conditions specified is not implied. Only one Absolute Maximum Rating should be applied at any one time.

2. Mounted on an FR4 board.

Electrical Characteristics¹

$V_{ADP} = 5V$, $T_A = -40^{\circ}C$ to $+85^{\circ}C$, unless otherwise noted. Typical values are at $T_A = 25^{\circ}C$.

Symbol	Description	Conditions	Min	Typ	Max	Units
Operation						
USB, ADP	USB Port or Adapter Voltage Range		4.0		5.5	V
V_{ADPP}	Adapter Present Indicator Threshold Voltage	USB Present	4.25	4.5	4.7	V
V_{U_DSBL}	ADP Voltage Level to Disable USB Charging		4.25	4.5	4.7	V
V_{UVLO}	Under-Voltage Lockout	Rising Edge		3.0		V
	Under-Voltage Lockout Hysteresis			150		mV
I_{OP}	Operating Current	CC Charge Current = 500mA		0.75	1.5	mA
I_{SLEEP}	Sleep Mode Current	AAT3686, AAT3686-3: $V_{BAT} = 4.25V$		0.3	1.0	μA
		AAT3686-1: $V_{BAT} = 4.25V$		1	3	
$I_{Leakage}$	Reverse Leakage Current from BAT Pin	$V_{BAT} = 4V$, USB, ADP Pins Open		1.0		μA
Voltage Regulation						
$V_{BAT_EOC}^1$	End of Charge Voltage Accuracy		4.158	4.2	4.242	V
$\Delta V_{BAT}/V_{BAT}$	EOC Voltage Tolerance			0.5		%
V_{MIN}	Preconditioning Voltage Threshold		2.8	3.0	3.15	V
V_{RCH}	Battery Recharge Voltage Threshold			$V_{BAT_EOC} - 0.1$		V
V_{USB_CHR}	USB Charge Reduction Regulation	No Connection on CHR Pin	4.3	4.5	4.64	V
V_{CHR}	CHR Pin Voltage Accuracy		1.9	2.0	2.1	V
Current Regulation						
I_{CH}	Charge Current		100		1500	mA
$\Delta I_{CH}/I_{CH}$	Charge Current Regulation Tolerance			10		%
V_{ADPSET}	ADPSET Pin Voltage	CC Mode		2.0		V
V_{USBH}	USBH Pin Voltage	CC Mode		2.0		V
V_{USBL}	USBL Pin Voltage	CC Mode		2.0		V
K_{IA}	Current Set Factor: I_{CHARGE}/I_{ADPSET}			4000		
K_{IUH}	Current Set Factor: I_{CHARGE}/I_{USBH}			2000		
K_{IUL}	Current Set Factor: I_{CHARGE}/I_{USBL}			2000		
Charging Devices						
$R_{DS(ON)A}$	Adapter Charging Transistor On Resistance	$V_{IN} = 5.5V$	0.2	0.25	0.35	Ω
$R_{DS(ON)U}$	USB Charging Transistor On Resistance	$V_{IN} = 5.5V$	0.4	0.5	0.65	Ω

1. The AAT3686 output charge voltage is specified over the 0° to $70^{\circ}C$ ambient temperature range; operation over the $-40^{\circ}C$ to $+85^{\circ}C$ temperature range is guaranteed by design.

Electrical Characteristics¹

$V_{ADP} = 5V$, $T_A = -40^{\circ}C$ to $+85^{\circ}C$, unless otherwise noted. Typical values are at $T_A = 25^{\circ}C$.

Symbol	Description	Conditions	Min	Typ	Max	Units
Logic Control / Protection						
$V_{USBSEL(H)}$	Input High Threshold		1.6			V
$V_{USBSEL(L)}$	Input Low Threshold				0.4	V
$V_{EN(H)}$	Input High Threshold		1.6			V
$V_{EN(L)}$	Input Low Threshold				0.4	V
$I_{EN(H)}$	EN Input Current	AAT3686-1 Only; $V_{EN} = 5V$			10	μA
$V_{ADPP\#}$	Output Low Voltage	ADPP# Pin Sinks 4mA			0.4	V
T_P	Preconditioning Time Out (ADP mode only)	$C_{CT} = 100nF$, $V_{ADP} = 5.5V$		25		Minute
T_C	Preconditioning and Constant Current Mode Time Out (ADP mode only)	$C_{CT} = 100nF$, $V_{ADP} = 5.5V$		3.0		Hour
T_V	Constant Voltage Mode Time Out (ADP mode only)	$C_{CT} = 100nF$, $V_{ADP} = 5.5V$		3.0		Hour
V_{STAT}	Output Low Voltage	STAT Pin Sinks 4mA			0.4	V
I_{STAT}	STAT Pin Current Sink Capability			8.0		mA
V_{OVP}	Over-Voltage Protection Threshold			4.4		V
I_{TK}/I_{CHG}	Pre-Charge Current	For Adapter or USBH Mode		10		%
		For USBL Mode		50		
I_{TERM}/I_{CHG}	Charge Termination Threshold Current	For Adapter or USBH Mode		7.5		%
		For USBL Mode		35		
I_{TS}	Current Source from TS Pin		70	80	90	μA
TS1	TS Hot Temperature Fault	Threshold	310	330	350	mV
		Hysteresis		15		
TS2	TS Cold Temperature Fault	Threshold	2.2	2.3	2.4	V
		Hysteresis		10		
I_{DATA}	DATA Pin Sink Current	DATA Pin is Active Low State	3			mA
$I_{ADPP\#}$	ADPP# Current Sink Capability	ADPP# Pin is Active Low State		8		mA
$V_{DATA(H)}$	Input High Threshold		1.6			V
$V_{DATA(L)}$	Input Low Threshold				0.4	V
SQ_{PULSE}	Status Request Pulse Width	Status Request	200			ns
t_{PERIOD}	System Clock Period			50		μs
f_{DATA}	Data Output Frequency			20		kHz
T_{REG}	Thermal Loop Regulation			90		$^{\circ}C$
T_{LOOP_IN}	Thermal Loop Entering Threshold			110		$^{\circ}C$
T_{LOOP_OUT}	Thermal Loop Exiting Threshold			85		$^{\circ}C$
T_{OVSD}	Over-Temperature Shutdown Threshold			145		$^{\circ}C$

1. The AAT3686 output charge voltage is specified over the 0° to $70^{\circ}C$ ambient temperature range; operation over the $-40^{\circ}C$ to $+85^{\circ}C$ temperature range is guaranteed by design.

Typical Characteristics

$I_{FASTCHARGE}$ vs. R_{SET}

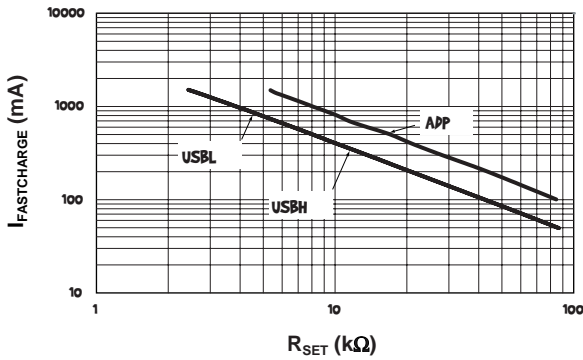

Battery Voltage vs. Supply Voltage

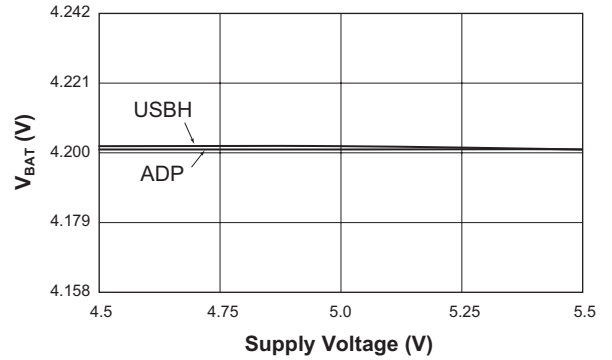

Recharge Voltage vs. Temperature

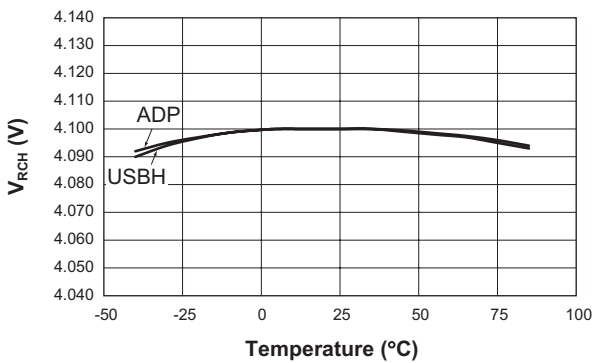

End of Charge Voltage vs. Temperature

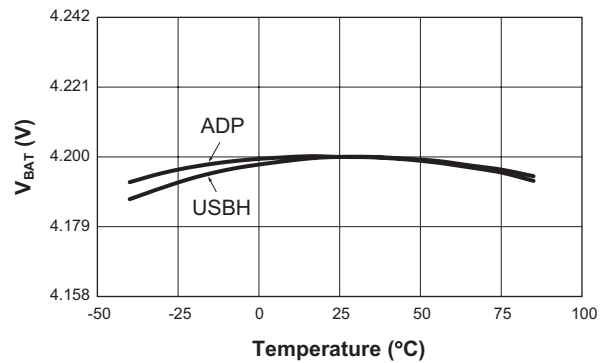

Preconditioning Threshold Voltage vs. Temperature

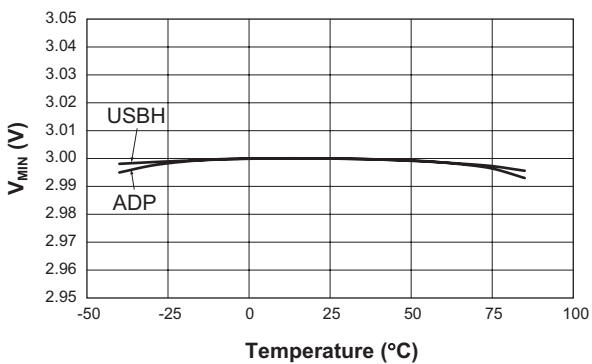

Preconditioning Charge Current vs. Temperature (ADPSET = 8.06kΩ; USBH = 8.06kΩ)

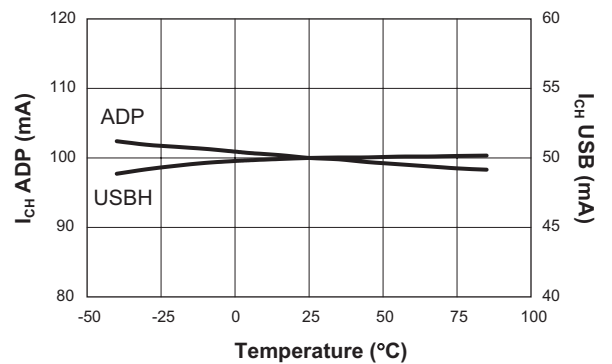

Typical Characteristics

Fast Charge Current vs. Temperature
(ADPSET = 8.0kΩ; USBH = 8.06kΩ)

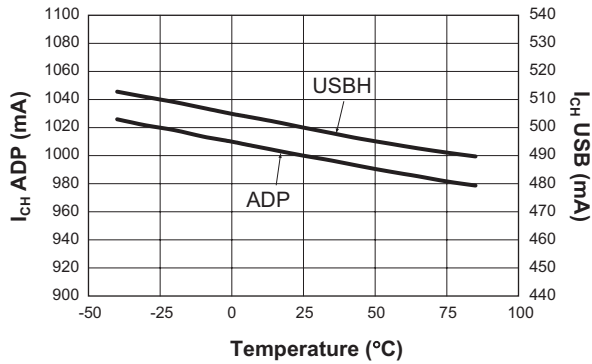

Charging Current vs. Battery Voltage
(Adapter; ADPSET = 8.06kΩ)

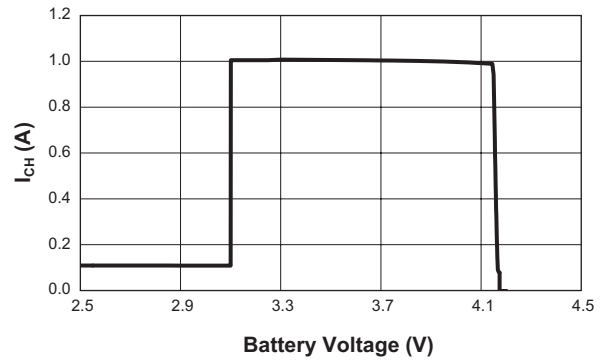

Charging Current vs. Battery Voltage
(USBH; USBH = 8.06kΩ)

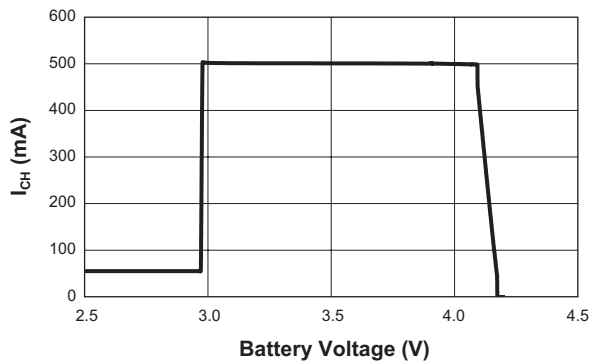

Charging Current vs. Battery Voltage
(USBL; USBL = 40.2kΩ)

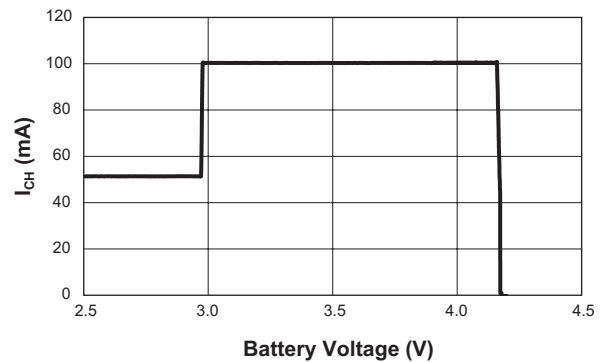

Fast Charge Current vs. Supply Voltage
(Adapter; ADPSET = 8.06kΩ)

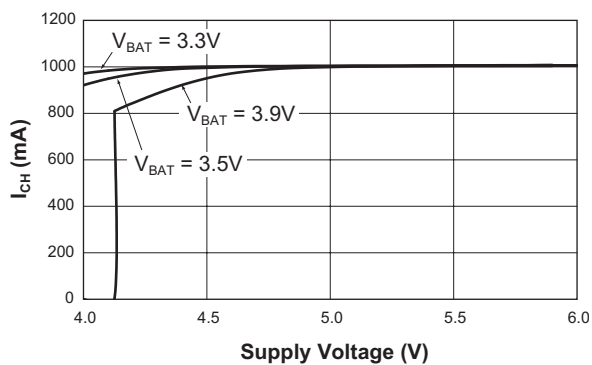

Fast Charge Current vs. Supply Voltage
(USBH; USBH = 8.06kΩ)

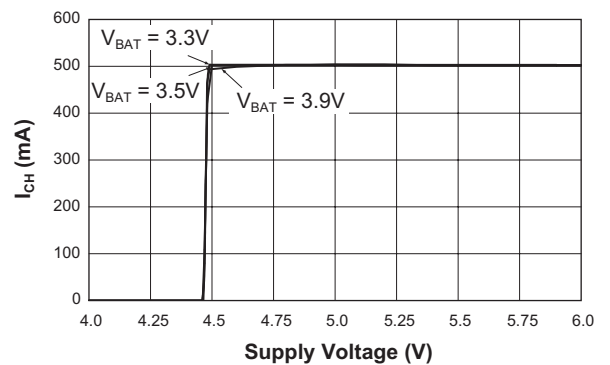

Typical Characteristics

Fast Charge Current vs. Supply Voltage
(USBL; USBL = 40.2kΩ)

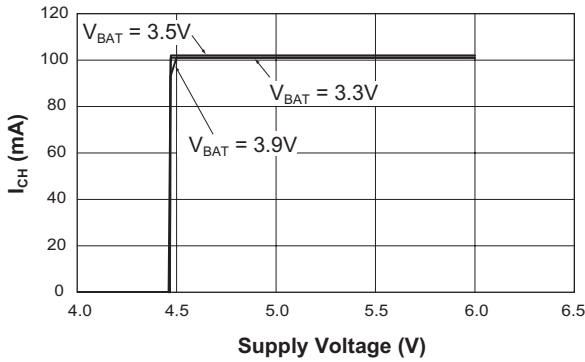

Fast Charge Current vs. Supply Voltage
(USBH; USBH = 8.06kΩ)

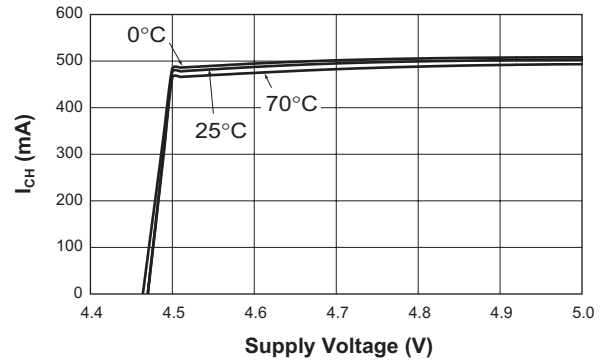

V_{IH} vs. Supply Voltage
EN Pin (Rising)

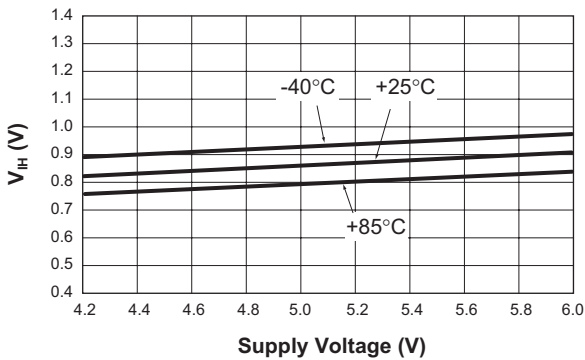

V_{IL} vs. Supply Voltage
EN Pin (Falling)

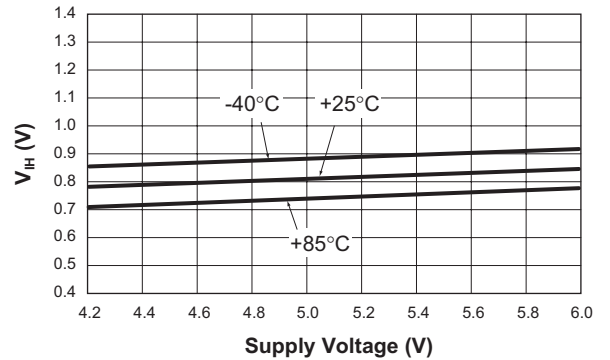

V_{IH} vs. Supply Voltage
USBSEL (Rising)

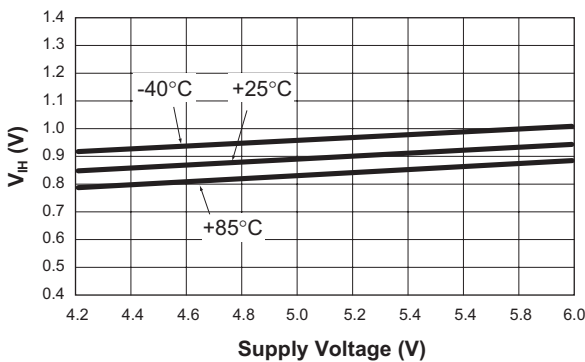

V_{IL} vs. Supply Voltage
USBSEL (Falling)

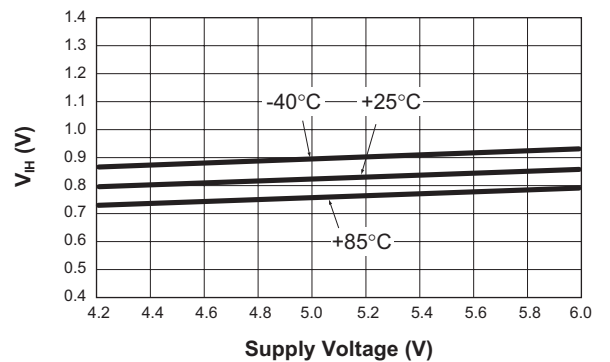

Typical Characteristics

Adapter Mode Supply Current vs. ADPSET Resistor

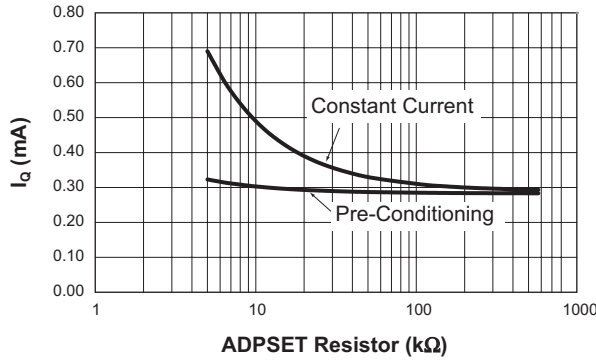

USB Charge Current vs. Time (USBH; USBH = 8.06kΩ)

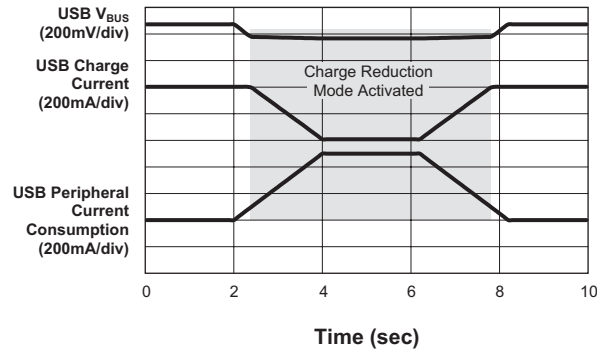

Counter Timeout vs. Temperature (CT = 0.1μF)

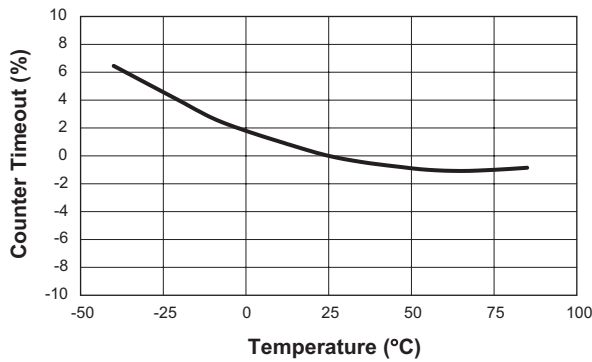

CT Pin Capacitance vs. Counter Timeout

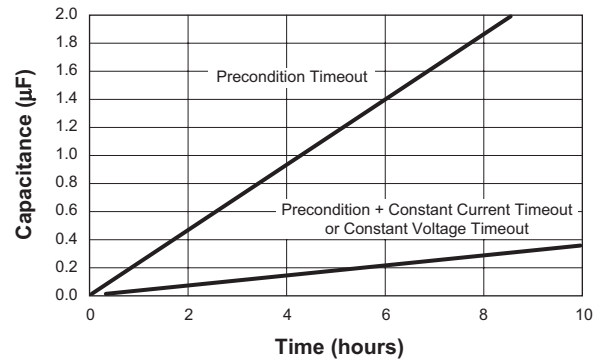

Temperature Sense Output Current vs. Temperature

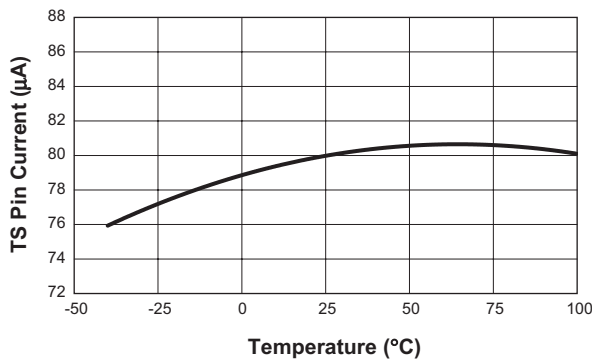

Functional Block Diagram

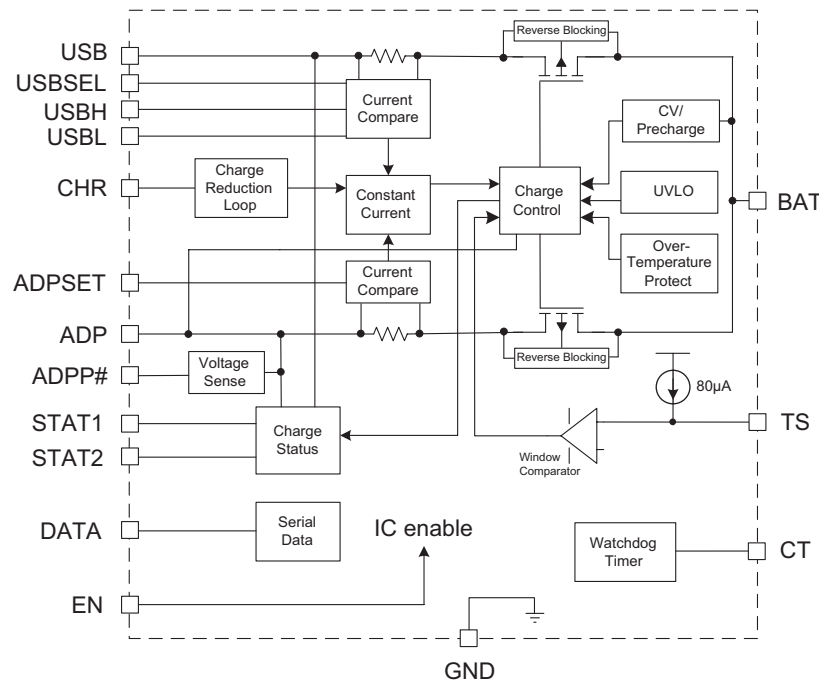

Functional Description

The AAT3686 is a highly integrated single-cell lithium-ion/polymer battery charger IC designed to operate with USB port and AC adapter inputs, while requiring a minimum number of external components. The AAT3686 precisely regulates battery charge voltage and current for 4.2V lithium-ion/polymer battery cells.

The adapter charge input constant current level can be programmed up to 1.5A for rapid charging applications. In the absence of a high current adapter input source, the AAT3686 can be powered from a USB port VBUS supply. Depending on the USB port type, the AAT3686 constant charge current can be externally programmed for two levels, USB high and USB low, for maximum constant current charge levels up to 500mA. Typically, the USB charge levels are set at 500mA and 100mA for the USBH and USBL modes; however, the user may program either mode to any level up to 500mA.

The USBH/L mode has automatic Charge Reduction Loop control to allow users to charge the battery with limited available current from a USB port, while maintaining the regulated port voltage. This system assures the battery charge function will not overload a USB port while charging if other system demands also share power with the respective port supply. The USB charge function is auto-

matically disabled when an adapter input power source greater than 4.4V is present.

Status monitor output pins are provided to indicate the battery charge status by directly driving two external LEDs. A serial interface output is available to report 22 various status states to a microcontroller.

Battery temperature and charge state are fully monitored for fault conditions. In the event of an over-voltage or over-temperature failure, the device will automatically shut down, thus protecting the charging device, control system, and the battery under charge. In addition to internal charge controller thermal protection, the AAT3686 also provides a temperature sense feedback function (TS pin) from the battery to shut down the device in the event the battery exceeds its own thermal limit during charging. All fault events are reported to the user either by the simple status LEDs or via the DATA pin function.

Charging Operation

Regardless of which charge input function is selected (i.e., either the adapter input or USB input), the AAT3686 has four basic modes for the battery charge cycle: pre-conditioning/trickle charge; constant current/fast charge; constant voltage; and end of charge (see Figure 1).

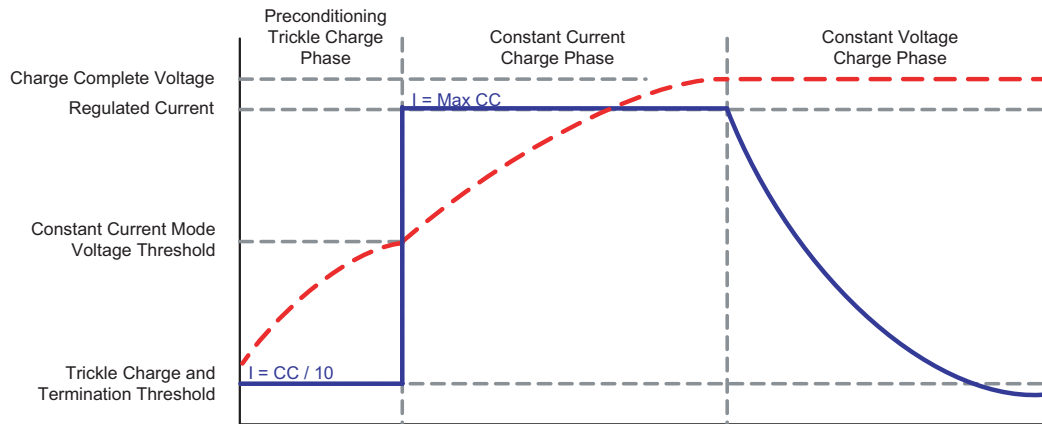

Figure 1: Current vs. Voltage Profile During Charging Phases.

Battery Preconditioning

Before the start of charging, the AAT3686 checks several conditions in order to assure a safe charging environment. The input supply must be above the minimum operating voltage, or under-voltage lockout threshold (V_{UVLO}), for the charging sequence to begin. Also, the cell temperature, as reported by a thermistor connected to the TS pin from the battery, must be within the proper window for safe charging. When these conditions have been met and a battery is connected to the BAT pin, the AAT3686 checks the state of the battery. If the cell voltage is below the preconditioning voltage threshold (V_{MIN}), the AAT3686 begins preconditioning the cell.

The battery preconditioning trickle charge current is equal to the fast charge constant current divided by 10 (USBL divided by 2). For example, if the programmed fast charge current is 500mA, then the preconditioning mode (trickle charge) current will be 50mA. Cell preconditioning is a safety precaution for a deeply discharged battery and also aids in limiting power dissipation in the pass transistor when the voltage across the device is at the greatest potential.

Fast Charge / Constant Current Charging

Cell preconditioning continues until the voltage on the BAT pin exceeds the preconditioning voltage threshold (V_{MIN}). At this point, the AAT3686 begins the constant current fast charging phase. The fast charge constant current (ICC) amplitude is determined by the charge mode, ADP, USBH or USBL, and is programmed by the user via the R_{SET} , R_{SETH} , and R_{SETL} resistors. The AAT3686 remains in constant current charge mode until the battery reaches the voltage regulation point, V_{BAT} .

Constant Voltage Charging

The system transitions to a constant voltage charging mode when the battery voltage reaches the output charge regulation threshold (V_{BAT}) during the constant current fast charge phase. The regulation voltage level is factory programmed to 4.2V ($\pm 1\%$). Charge current in the constant voltage mode drops as the battery cell under charge reaches its maximum capacity.

End of Charge Cycle Termination and Recharge Sequence

When the charge current drops to 7.5% (35% for USBL) of the programmed fast charge current level in the constant voltage mode, the device terminates charging and goes into a standby state. The charger will remain in a standby state until the battery voltage decreases to a level below the battery recharge voltage threshold (V_{RCH}).

When the input supply is disconnected or drops below UVLO or $EN = 0$, the charger will automatically enter power-saving sleep mode. Consuming an ultra-low 0.3 μ A in sleep mode (1 μ A for AAT3686-1), the AAT3686 minimizes battery drain when it is not charging. This feature is particularly useful in applications where the input supply level may fall below the battery charge or under-voltage lockout level. In such cases where the AAT3686 input voltage drops, the device will enter sleep mode and automatically resume charging once the input supply has recovered from its fault condition.

System Operation Flow Chart

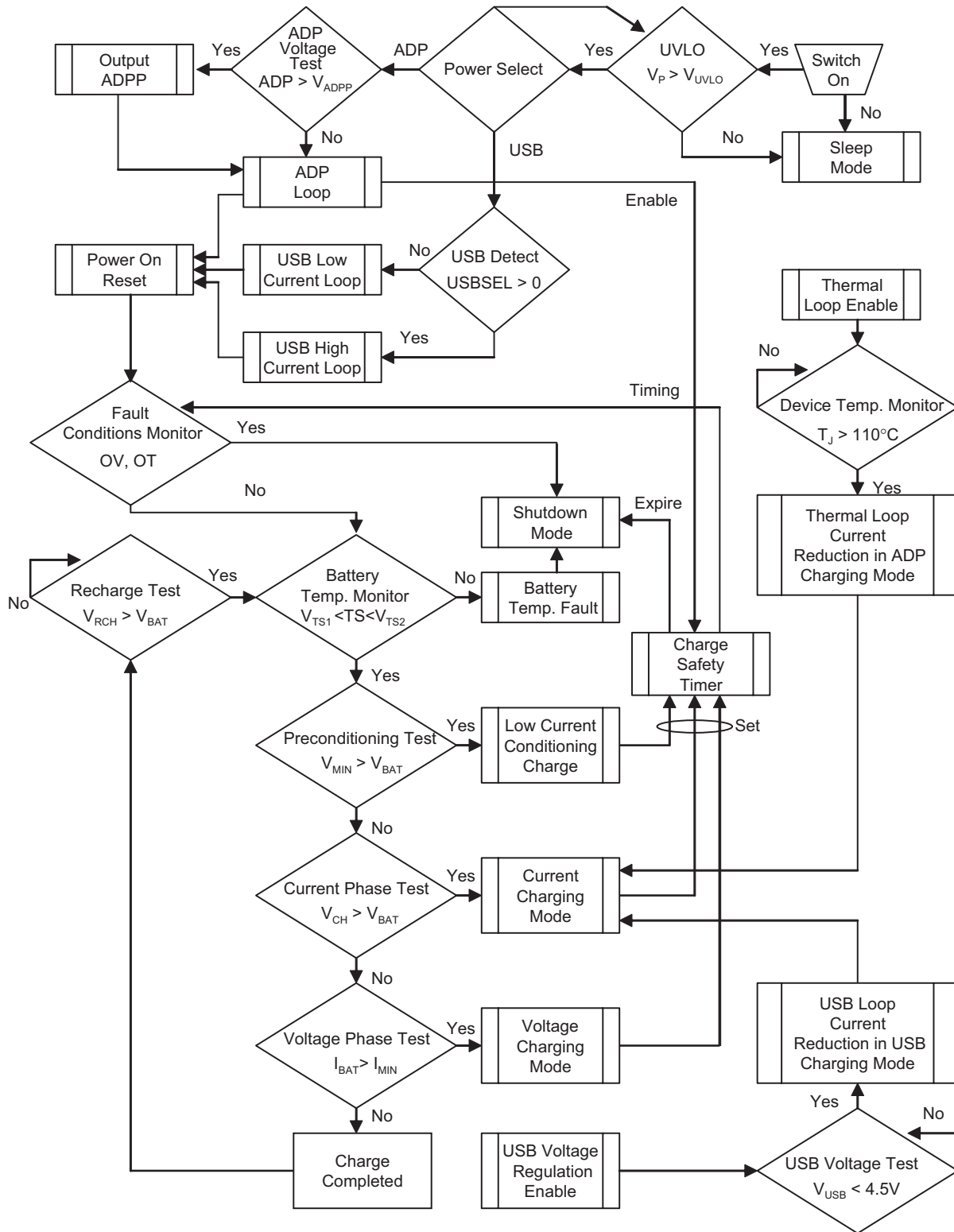

Application Information

AC Adapter / USB System Power Charging

Adapter Mode

In the adapter mode, constant current charge levels up to 1.5A can be programmed by the user. The AAT3686 system control will always select the adapter input over the USB supply input whenever adapter voltage is present on the ADP pin. The AAT3686 will operate from the adapter input over a 4.0V to 5.5V range.

The constant current fast charge current for the adapter input mode is set by the R_{SET} resistor connected between the ADPSET and ground. Refer to Table 1 for recommended R_{SET} values for a desired constant current charge level. The presence of voltage on the adapter input is indicated by the ADPP# pin function. This indicator pin is an open drain and will pull the ADPP# pin low when voltage is detected on the ADP pin. The precise charging function in the adapter mode may be read from the DATA pin and/or status LEDs. Please refer to the Battery Charge Status Indication discussion in this datasheet for further details on data reporting.

Thermal Loop Control

Due to the integrated nature of the linear charging control pass device for the adapter mode, a special thermal loop control system has been employed to maximize charging current under all operation conditions. The thermal management system measures the internal circuit die temperature and reduces the fast charge current when the device exceeds a preset internal temperature control threshold. Once the thermal loop control becomes active, the fast charge current is initially reduced by a factor of 0.44.

The initial thermal loop current can be estimated by the following equation:

$$I_{TLOOP} = I_{CC} \cdot 0.44$$

The thermal loop control re-evaluates the circuit die temperature every three seconds and adjusts the fast charge current back up in small steps to the full fast charge current level or until an equilibrium current is discovered and maximized for the given ambient temperature condition. The thermal loop controls the system charge level;

therefore, the AAT3686 will always provide the highest level of constant current in the fast charge mode possible for any given ambient temperature condition.

Adapter Input Charge Inhibit and Resume

The AAT3686 has an under-voltage lockout and power on reset feature so that the charger will suspend charging and shut down if the input supply to the adapter pin drops below the UVLO threshold. When power is re-applied to the adapter pin or the UVLO condition recovers and $ADP > V_{BATr}$, the system charge control will assess the state of charge on the battery cell and will automatically resume charging in the appropriate mode for the condition of the battery.

USB Mode

The AAT3686 provides an input for intelligent USB charging. When no voltage is present on the adapter input pin, the charge controller will automatically switch to accepting power from the USB input. The USB charge mode provides two programmable fast charge levels up to 500mA each, USB high and USB low, USBH and USBL, respectively. The USBH or USBL modes may be externally selected by the USB select pin (USBSEL). USBSEL is internally pulled low through a 1M Ω resistor. When the USBSEL pin is connected to a logic high level, the USBH level will be active. Conversely, when USBSEL is pulled to a logic low level (ground), the USBL level will be used for charging. Typically, USBH is set for 500mA and USBL is set for 100mA. However, these two USB charge levels may be user programmed to any level between 50mA and 500mA by selecting the appropriate resistor values for R_{SETH} and R_{SETL} . Refer to Table 1 for recommended R_{SETH} and R_{SETL} values for the desired USB input constant current charge levels.

USB Charge Reduction

In many instances, product system designers do not know the real properties of a potential USB port used to supply power to the battery charger. Typically, powered USB ports found on desktop and notebook PCs should supply up to 500mA. In the event a USB port being used to supply the charger is unable to provide the programmed fast charge current or if the system under charge must also share supply current with other functions, the AAT3686 will automatically reduce USB fast charge current to maintain port integrity and protect the host system.

I _{CC}	ADP R _{SET} (kΩ)	USBH R _{SET} (kΩ)	USBL R _{SET} (kΩ)
50	N/A	86.6	86.6
75	N/A	57.6	57.6
100	84.5	42.2	42.2
200	43.2	21.0	20.5
300	28.0	13.7	13.7
400	21.0	10.2	10.2
500	16.9	8.06	8.06
600	13.3	6.65	6.65
700	11.5	5.62	5.62
800	10.2	4.87	4.87
900	9.09	4.32	4.32
1000	8.06	3.83	3.83
1100	7.32	3.48	3.48
1200	6.65	3.16	3.16
1300	6.04	2.87	2.87
1400	5.62	2.67	2.67
1500	5.36	2.43	2.43

Table 1: Resistor Values.

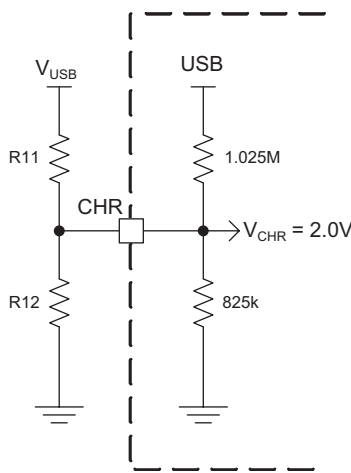

Figure 2: Internal Equivalent Circuit for the CHR Pin.

The USB charge reduction system becomes active when the voltage on the USB input falls below the USB charge reduction threshold (V_{USBCHR}), which is typically 4.5V. Regardless of which USB charge function is selected (USBH or USBL), the charge reduction system will reduce the fast charge current level in a linear fashion until the voltage sensed on the USB input recovers above the charge reduction threshold voltage. The USB charge reduction threshold (V_{USBCHR}) can be externally set to a value lower than 4.5V by placing a resistor divider network between V_{USB} and ground with the center connected to the CHR pin. The USB charge reduction feature can be

disabled by connecting a 10kΩ resistor from the CHR pin directly to the USB input pin (see Figure 2).

The following equation can be used to approximate a USB charge reduction threshold below 4.5V:

$$V_{USBCHR} = 2.0V \div \frac{R12}{R12 + R11}$$

Where $R11/R12 \ll 1M\Omega$.

USB Input Charge Inhibit and Resume

The AAT3686 UVLO and power on reset feature will function when the USB input pin voltage level drops below the UVLO threshold. At this point, the charger will suspend charging and shut down. When power is re-applied to the USB pin or the UVLO condition recovers, the system charge control will assess the state of charge on the battery cell and will automatically resume charging in the appropriate mode for the condition of the battery.

Enable / Disable

The AAT3686 provides an enable function to control the charger IC on and off. The enable (EN) pin is active high. When pulled to a logic low level, the AAT3686 will be shut down and forced into the sleep state. Charging will be halted regardless of the battery voltage or charging state. When the device is re-enabled, the charge control circuit will automatically reset and resume charging functions with the appropriate charging mode based on the battery charge state and measured cell voltage.

Programming Charge Current

The fast charge constant current charge level for both adapter and USB input modes are programmed with set resistors placed between the ADPSET, USBH, and USBL pins and ground. The accuracy of the fast charge, as well as the preconditioning trickle charge current, is dominated by the tolerance of the set resistor used. For this reason, 1% tolerance metal film resistors are recommended for the set resistor function.

Fast charge constant current levels from 50mA to 1.5A can be set by selecting the appropriate resistor value from Table 1. The R_{SET} resistor should be connected between the ADPSET pin and ground.

The USB input fast charge constant current charge control provides for two current set levels, USBH and USBL. The USBSEL pin is used to select the high or low charge current levels in the USB charge mode. When the USBSEL pin

is pulled to a voltage level above the $V_{USBSEL(H)}$ threshold, the USBH current level will be selected. Conversely, this pin should be pulled below $V_{USBSEL(L)}$ to enable the USBL charge level. Typically, the two R_{SETH} and R_{SETL} resistors for the USBH and USBL functions are fixed for 500mA and 100mA USB fast charge levels. However, these two charge levels can be set to any level between 50mA and 500mA depending upon the system design requirements for a given USB charge application. Refer to Table 1 and Figure 3 for recommended R_{SETH} and R_{SETL} values.

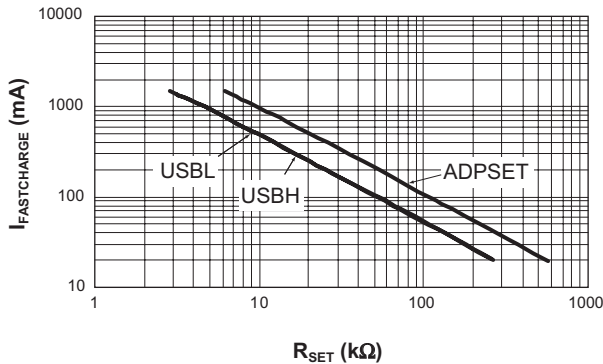

Figure 3: $I_{FASTCHARGE}$ VS. R_{SET} .

Protection Circuitry

Programmable Watchdog Timer

The AAT3686 contains a watchdog timing circuit for the adapter input charging mode. No watchdog timing functions are active for the USB input mode. Typically, a 0.1 μ F ceramic capacitor is connected between the CT pin and ground. When a 0.1 μ F ceramic capacitor is used, the device will time a shutdown condition if the trickle charge mode exceeds 25 minutes and a combined trickle charge plus fast charge mode of three hours. When the device transitions to the constant voltage mode, the timing counter is reset and will time out after three hours and shut down the charger (see Table 2).

Mode	Time
Trickle Charge Time Out	25 minutes
Trickle Charge + Fast Charge (CC) Time Out	3 hours
Constant Voltage (VC) Mode Time Out	3 hours

Table 2: Summary for a 0.1 μ F Used for the Timing Capacitor.

The CT pin is driven by a constant current source and will provide a linear response to increases in the timing capacitor value. Thus, if the timing capacitor were to be doubled from the nominal 0.1 μ F value, the time-out times would be doubled.

If the programmable watchdog timer function is not needed, it can be disabled by connecting the CT pin to ground. The CT pin should not be left floating or unterminated, as this will cause errors in the internal timing control circuit.

The constant current provided to charge the timing capacitor is very small, and this pin is susceptible to noise and changes in capacitance value. Therefore, the timing capacitor should be physically located on the printed circuit board layout as closely as possible to the CT pin. Since the accuracy of the internal timer is dominated by the capacitance value, 10% tolerance or better ceramic capacitors are recommended. Ceramic capacitor materials, such as X7R and X5R type, are a good choice for this application.

Over-Voltage Protection

An over-voltage event is defined as a condition where the voltage on the BAT pin exceeds the maximum battery charge voltage and is set by the over-voltage protection threshold (V_{OVP}). If an over-voltage condition occurs, the AAT3686 charge control will shut down the device until voltage on the BAT pin drops below the over-voltage protection threshold (V_{OVP}). The AAT3686 will resume normal charging operation after the over-voltage condition is removed. During an over-voltage event, the STAT LEDs will report a system fault, and the actual fault condition may be read via the DATA pin signal.

Over-Temperature Shutdown

The AAT3686 has a thermal protection control circuit which will shut down charging functions should the internal die temperature exceed the preset thermal limit threshold.

Battery Temperature Fault Monitoring

In the event of a battery over-temperature condition, the charge control will turn off the internal pass device and report a battery temperature fault on the DATA pin function. The STAT LEDs will also display a system fault. After the system recovers from a temperature fault, the device will resume charging operation.

The AAT3686 checks battery temperature before starting the charge cycle, as well as during all stages of

charging. This is accomplished by monitoring the voltage at the TS pin. This system is intended to use negative temperature coefficient thermistors (NTC), which are typically integrated into the battery package. Most of the commonly used NTC thermistors in battery packs are approximately 10kΩ at room temperature (25°C).

The TS pin has been specifically designed to source 80μA of current to the thermistor. The voltage on the TS pin that results from the resistive load should stay within a window from 335mV to 2.32V. If the battery becomes too hot during charging due to an internal fault, the thermistor will heat up and reduce in value, pulling the TS pin voltage lower than the TS1 threshold and the AAT3686 will signal the fault condition.

If the use of the TS pin function is not required by the system, it should be terminated to ground using a 10kΩ resistor. Alternatively, on the AAT3686-1, the TS pin may be left open.

Battery Charge Status Indication

The AAT3686 indicates the status of the battery under charge with two different systems. First, the device has two status LED driver outputs. These two LEDs can indicate simple functions such as no battery charge activity, battery charging, charge complete, and charge fault. The AAT3686 also provides a bi-directional data reporting function so that a system microcontroller can interrogate the DATA pin and read any one of 22 system states.

Status Indicator Display

Simple system charging status states can be displayed using one or two LEDs in conjunction with the STAT1 and STAT2 pins on the AAT3686. These two pins are simple switches to connect the LED cathodes to ground. It is not necessary to use both display LEDs if a user simply wants to have a single lamp to show “charging” or “not charging.” This can be accomplished by using the STAT1 pin and a single LED. Using two LEDs and both STAT pins simply gives the user more information to the charging states. Refer to Table 3 for LED display definitions.

The LED anodes should be connected to either V_{USB} or V_{ADP}, depending upon system design requirements. The LEDs should be biased with as little current as necessary to create reasonable illumination; therefore, a ballast

resistor should be placed between the LED cathodes and the STAT1/2 pins. LED current consumption will add to the overall thermal power budget for the device package, so it is wise to keep the LED drive current to a minimum. 2mA should be sufficient to drive most low-cost green or red LEDs. It is not recommended to exceed 8mA for driving an individual status LED.

Event Description	STAT1	STAT2
Charge Disabled or Low Supply	Off	Off
Charge Enabled Without Battery	Flash ¹	Flash ¹
Battery Charging	On	Off
Charge Completed	Off	On
Fault	On	On

Table 3: Status LED Display Conditions.

The required ballast resistor value can be estimated using the following formulas:

For connection to the adapter supply:

$$R_{B(STAT1/2)} = \frac{V_{ADP} - V_{F(LED)}}{I_{LED(STAT1/2)}}$$

Example:

$$R_{B(STAT1)} = \frac{5.5V - 2.0V}{2mA} = 1.75k\Omega$$

Note: Red LED forward voltage (V_F) is typically 2.0V @ 2mA.

For connection to the USB supply:

$$R_{B(STAT1/2)} = \frac{V_{USB} - V_{F(LED)}}{I_{LED(STAT1/2)}}$$

Example:

$$R_{B(STAT2)} = \frac{5.0V - 3.2V}{2mA} = 900\Omega$$

Note: Green LED forward voltage (V_F) is typically 3.2V @ 2mA.

The four status LED display conditions are described in Table 3.

1. Flashing rate depends on output capacitance.

Digital Charge Status Reporting

The AAT3686 has a comprehensive digital data reporting system by use of the DATA pin feature. This function can provide detailed information regarding the status of the charging system. The DATA pin is a bi-directional port which will read back a series of data pulses when the system microcontroller asserts a request pulse. This single strobe request protocol will invoke one of 22 possible return pulse counts which the microcontroller can look up based on the serial report table shown in Table 4.

The DATA pin function is active low and should normally be pulled high to V_{ADP} or V_{USB} . This data line may also be pulled high to the same level as the high state for the logic I/O port on the system microcontroller. In order for the DATA pin control circuit to generate clean, sharp

edges for the data output and to maintain the integrity of the data timing for the system, the pull-up resistor on the data line should be low enough in value so that the DATA signal returns to the high state without delay. If too small a pull-up resistor is used, the strobe pulse from the system microcontroller could exceed the maximum pulse time and the DATA output control could issue false status reports. A 1.5kΩ resistor is recommended when pulling the DATA pin high to 5.0V on either V_{ADP} or V_{USB} inputs. If the data line is pulled high to a voltage level less than 5.0V, the pull-up resistor can be calculated based on a recommended minimum pull-up current of 3mA. Use the following formula:

$$R_{PULL_UP} \leq \frac{V_{PULL_UP}}{3mA}$$

Number	DATA Report Status	Number	DATA Report Status
1	Chip Over-Temperature Shutdown	13	USBH Battery Condition Mode
2	Battery Temperature Fault	14	USBH Charge Reduction in Constant Current Mode
3	Over-Voltage Turn Off	15	USBH Constant Current Mode
4	Not Used	16	USBH Constant Voltage Mode
5	ADP Watchdog Time-Out in Battery Condition Mode	17	USBH End of Charging
6	ADP Battery Condition Mode	18	USBL Battery Condition Mode
7	ADP Watchdog Time-Out in Constant Current Mode	19	USBL Charge End of Charging Reduction in Constant Current Mode
8	ADP Thermal Loop Regulation in Constant Current Mode	20	USBL Constant Current Mode
9	ADP Constant Current Mode	21	USBL Constant Voltage Mode
10	ADP Watchdog Time-Out in Constant Voltage Mode	22	USBL End of Charging
11	ADP Constant Voltage Mode	23	Data Report Error
12	ADP End of Charging		

Table 4: Serial Data Report Table.

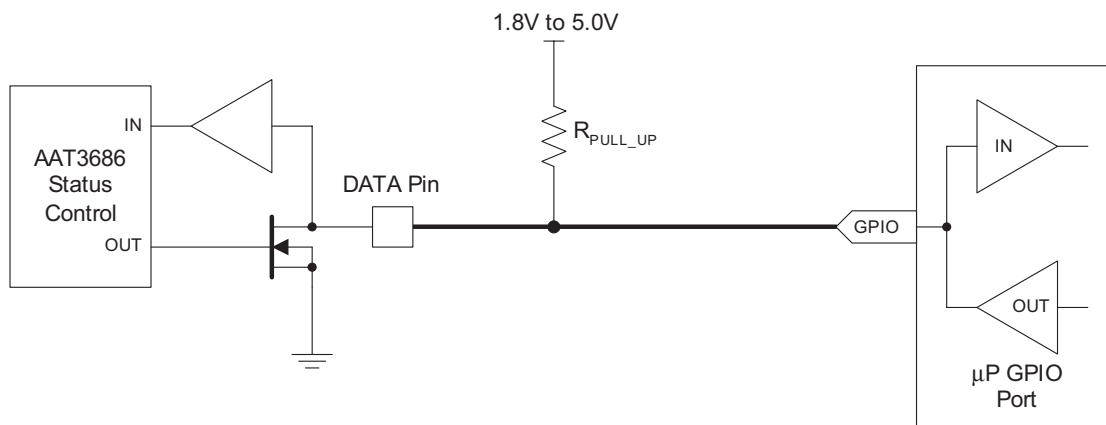

Figure 4: Data Pin Application Circuit.

Data Timing

The system microcontroller should assert an active low data request pulse for minimum duration of 200ns; this is specified by the SQ_{PULSE} . Upon sensing the rising edge of the end of the data request pulse, the AAT3686 status data control will reply the data word back to the system microcontroller after a delay defined by the data report time specification $T_{DATA(RPT)}$. The period of the following group of data pulses will be defined by the T_{DATA} specification.

Thermal Considerations

The AAT3686 is offered in a 3x4mm TDFN package and a 4x4mm TDFN package, each of which can provide up to 2.7W of power dissipation when it is properly bonded to a printed circuit board and has a maximum thermal resistance of 37°C/W. Many considerations should be taken into account when designing the printed circuit board layout, as well as the placement of the charger IC package in proximity to other heat generating devices in a given application design. The ambient temperature around the charger IC will also have an effect on the thermal limits of a battery charging application. The maximum limits that can be expected for a given ambient condition can be estimated by the following discussion.

First, the maximum power dissipation for a given situation should be calculated:

$$\text{Eq. 1: } P_D = [(V_{IN} - V_{BAT}) \cdot I_{CC} + (V_{IN} \cdot I_{OP})]$$

Where:

P_D = Total power dissipation by the device

V_{IN} = Either V_{ADP} or V_{USB} , depending on which mode is selected

V_{BAT} = Battery voltage as seen at the BAT pin

I_{CC} = Maximum constant fast charge current programmed for the application

I_{OP} = Quiescent current consumed by the charger IC for normal operation

Next, the maximum operating ambient temperature for a given application can be estimated based on the thermal resistance of the 3x4mm and 4x4mm TDFN packages when sufficiently mounted to a PCB layout and the internal thermal loop temperature threshold.

$$\text{Eq. 2: } T_A = T_J - (\theta_{JA} \cdot P_D)$$

Where:

T_A = Ambient temperature in degrees C

T_J = Maximum device junction temperature below the thermal loop threshold

P_D = Total power dissipation by the device

θ_{JA} = Package thermal resistance in °C/W

Timing Diagram

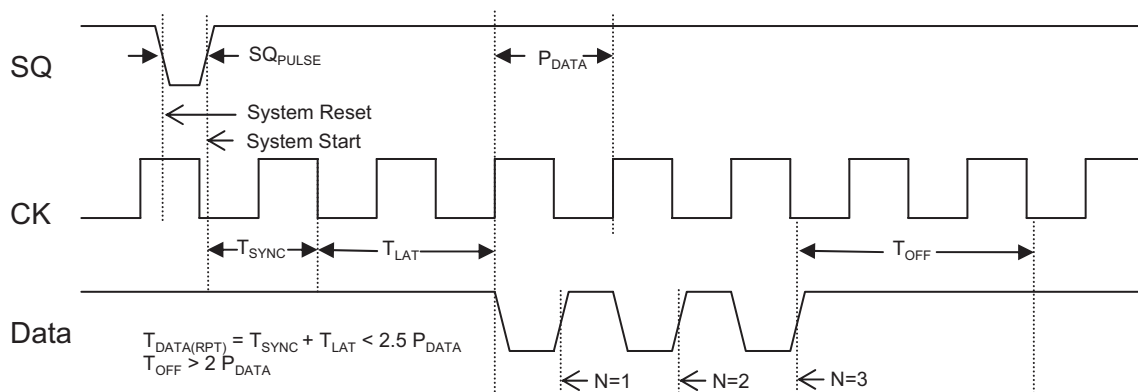

Example:

For an application where the fast charge current for the adapter mode is set to 1A, $V_{ADP} = 5.0V$, and the worst case battery voltage is 3.0V, what is the maximum ambient temperature where the thermal limiting will become active?

Given:

$$V_{ADP} = 5.0V$$

$$V_{BAT} = 3.0V$$

$$I_{CC} = 1A$$

$$I_{OP} = 0.75mA$$

$$T_j = 110^{\circ}C$$

$$\theta_{JA} = 37^{\circ}C/W$$

Using Equation 3, calculate the device power dissipation for the stated condition:

$$\begin{aligned} \text{Eq. 3: } P_D &= (5.0V - 3.0V)(1A) + (5.0V \cdot 0.75mA) \\ &= 2.00375W \end{aligned}$$

The maximum ambient temperature before the AAT3686 thermal loop becomes active can now be calculated using Equation 4:

$$\begin{aligned} \text{Eq. 4: } T_A &= 110^{\circ}C - (37^{\circ}C/W \cdot 2.00375W) = 35.86^{\circ}C \\ &= 35.86^{\circ}C \end{aligned}$$

Therefore, under the stated conditions for this worst case power dissipation example, the AAT3686 will enter the thermal loop and lower the fast charge constant current when the ambient operating temperature rises above 35.86°C.

Capacitor Selection

Input Capacitor

In general, it is good design practice to place a decoupling capacitor between the VADP and VUSB pins and ground. An input capacitor in the range of 1 μ F to 22 μ F is recommended. If the source supply is unregulated, it may be necessary to increase the capacitance to keep the input voltage above the under-voltage lockout threshold during device enable and when battery charging is initiated.

If the AAT3686 adapter input is to be used in a system with an external power supply source, such as a typical AC-to-DC wall adapter, then a C_{IN} capacitor in the range of 10 μ F should be used. A larger input capacitor in this application will minimize switching or power bounce effects when the power supply is "hot plugged." Likewise, a 10 μ F or greater input capacitor is recommended for the USB input to help buffer the effects of USB source power switching, noise, and input cable impedance.

Output Capacitor

The AAT3686 only requires a 1 μ F ceramic capacitor on the BAT pin to maintain circuit stability. This value should be increased to 10 μ F or more if the battery connection is made any distance from the charger output. If the AAT3686 is to be used in applications where the battery can be removed from the charger, such as in the case of desktop charging cradles, an output capacitor greater than 10 μ F may be required to prevent the device from cycling on and off when no battery is present.

Printed Circuit Board Layout Considerations

For the best results, it is recommended to physically place the battery pack as close to the AAT3686 BAT pin as possible. To minimize voltage drops on the PCB, keep the high current carrying traces adequately wide. For maximum power dissipation of the AAT3686 TDFN packages, the metal substrate should be solder bonded to the board. It is also recommended to maximize the substrate contact to the PCB ground plane layer to further increase local heat dissipation. Refer to the AAT3686 evaluation board for a good layout example.

AAT3686 Evaluation Board Schematic Diagram

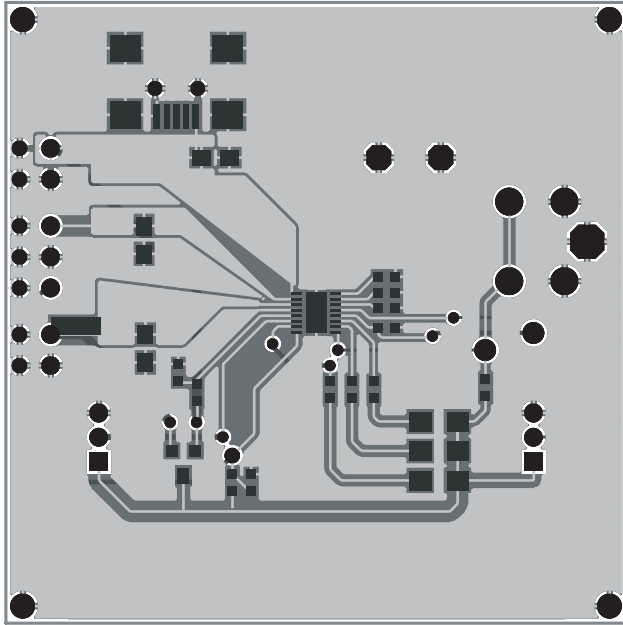

Figure 5: AAT3686 Evaluation Board Component Side Layout.

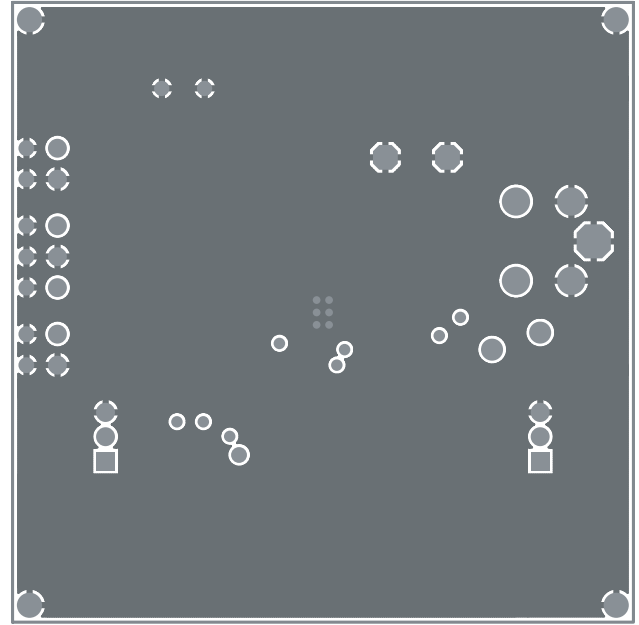

Figure 6: AAT3686 Evaluation Board Solder Side Layout.

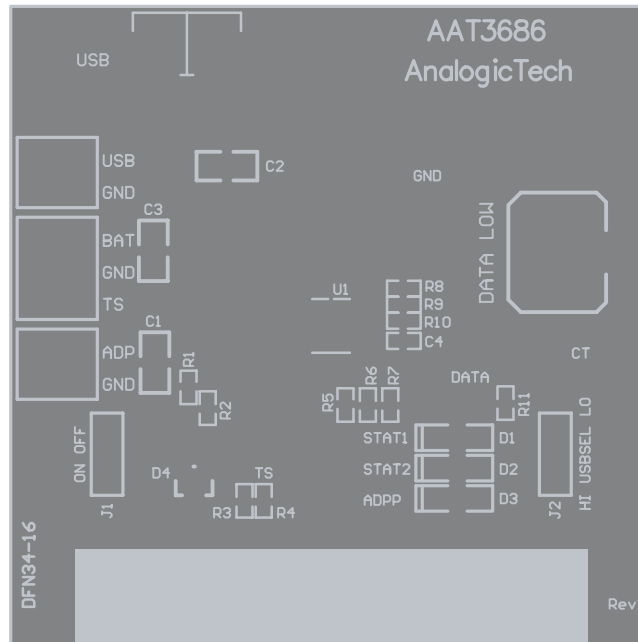

Figure 7: AAT3686 Evaluation Board Assembly Layout.

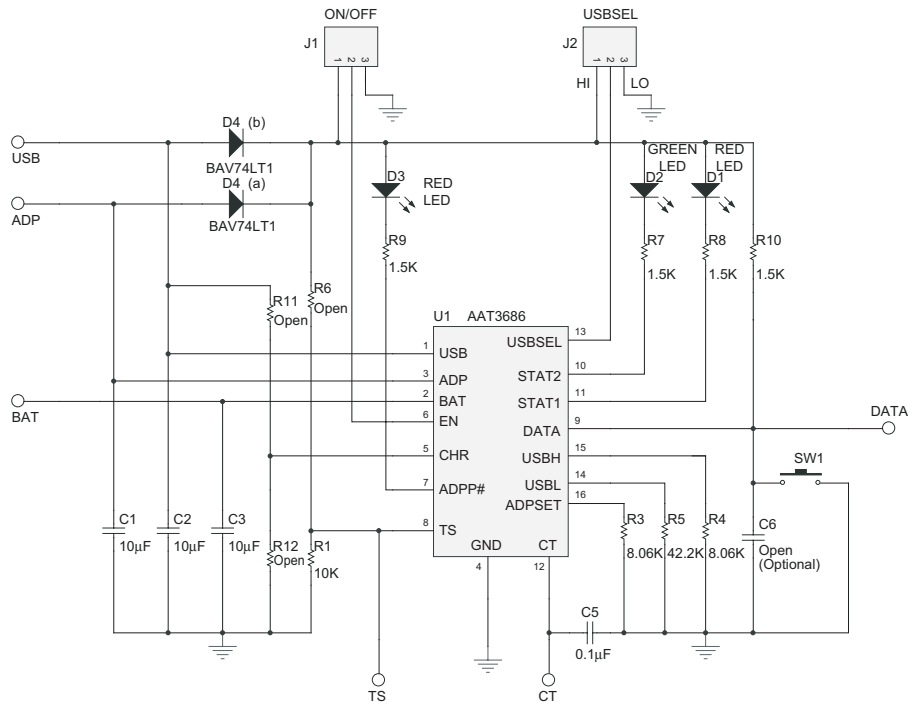

Figure 8: AAT3686 Evaluation Board Schematic Diagram.

AAT3686 Evaluation Board Bill of Materials (BOM)

Quantity	Description	Desig.	Footprint	Manufacturer	Part #
2	Test Pin	TS, CT		Mill-Max	6821-0-0001-00-00-08-0
2	Conn Term Block 2.54mm 2POS	USB, GND/ ADP, GND	TBLOK2	Phoenix Contact	277-1274-ND
1	Conn Term Block 2.54mm 3POS	BAT, TS, GND	TBLOK3	Phoenix Contact	277-1273-ND
1	USB 2.0 Receptacle, 5POS	USB	USB-MINI-B	Hirose Electronic Co., Ltd.	H2959CT-ND
3	Capacitor, Ceramic, 10µF 6.3V 10% X5R 0805	C1, 2, 3	0805	Murata	490-1717-1-ND
1	Capacitor, Ceramic, 0.1µF 25V 10% X5R 0603	C5	0603	Murata	478-1244-2-ND
2	Typical Red LED	D1, D3	1206LED	Chicago Miniature Lamp	CMD15-21SRC/TR8
1	Typical Green LED	D2	1206LED	Chicago Miniature Lamp	CMD15-21SRC/TR8
1	Switching Diode	D4 a, b	SOT23-3	On Semi	BAV74LT1
2	Header, 3-Pin	J1, 2	Header 2mm-3	Sullins	6821-0-0001-00-00-08-0
1	RES 10kW 1/16W 5% 0603 SMD	R1	0603	Panasonic/ECG	P10KJTR-ND
1	RES 8.06kW 1/16W 1% 0603 SMD	R3, 4	0603	Panasonic/ECG	P9.76KHCT-ND
1	RES 42.2kW 1/16W 1% 0603 SMD	R5	0603	Panasonic/ECG	P42.2KHTR-ND
4	RES 1.5kW 1/16W 5% 0603 SMD	R7, 8, 9, 10	0603	Panasonic/ECG	P1.5KCGCT-ND
1	Switch Tact 6mm SPST H = 5.0mm	SW1	Switch	ITT Industries/ C&K Div	CKN9012-ND
1	AAT3686 USB Port/AC Adapter Lithium-Ion/Polymer Battery Charger	U1	TDFN34-16; TDFN44-16	AnalogicTech	AAT3686IRN-4.2 AAT3686IXN-4.2

Ordering Information

Package	Marking ¹	Part Number (Tape and Reel) ²
TDFN34-16	PHXY	AAT3686IRN-4.2-T1
TDFN44-16	PHXY	AAT3686IXN-4.2-T1
TDFN44-16	SKXY	AAT3686IXN-4.2-1-T1
TDFN44-16	YCX	AAT3686IXN-4.2-3-T1



All AnalogicTech products are offered in Pb-free packaging. The term “Pb-free” means semiconductor products that are in compliance with current RoHS standards, including the requirement that lead not exceed 0.1% by weight in homogeneous materials. For more information, please visit our website at <http://www.analogictech.com/about/quality.aspx>.

Package Information³

TDFN34-16

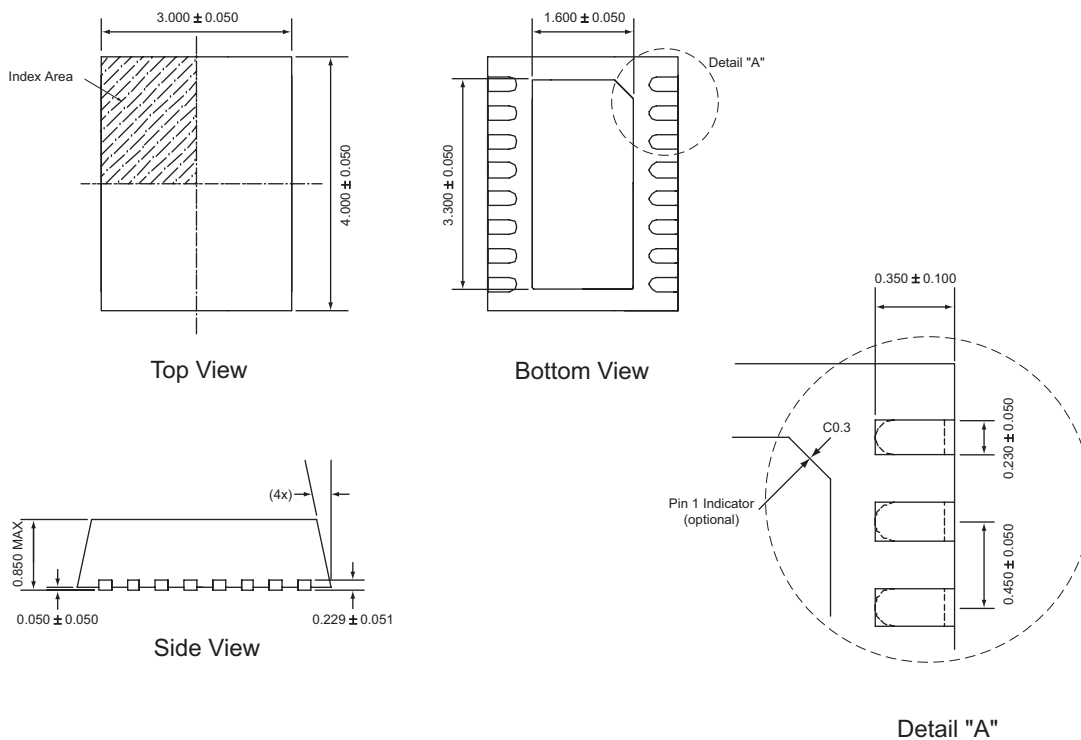

All dimensions in millimeters.

1. XYY = assembly and date code.
 2. Sample stock is generally held on part numbers listed in **BOLD**.
 3. The leadless package family, which includes QFN, TQFN, DFN, TDFN and STDFN, has exposed copper (unplated) at the end of the lead terminals due to the manufacturing process. A solder fillet at the exposed copper edge cannot be guaranteed and is not required to ensure a proper bottom solder connection.

TDFN44-16

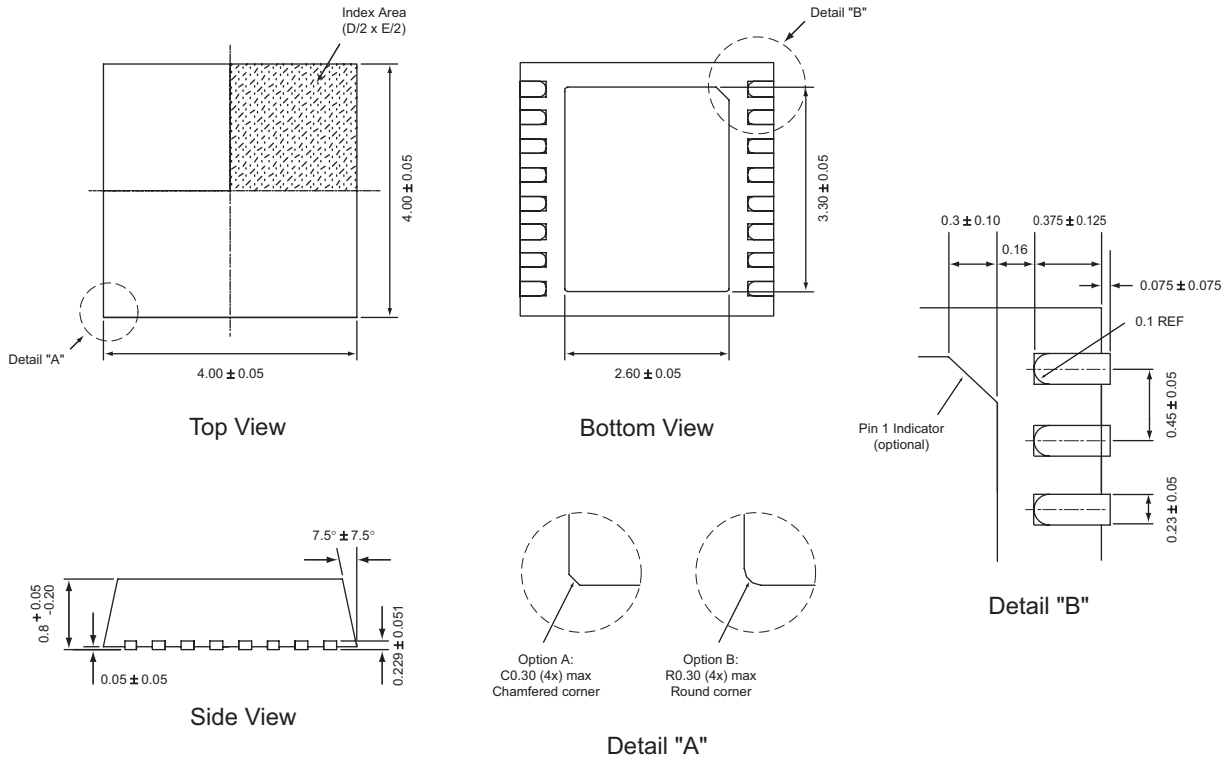

All dimensions in millimeters.

Advanced Analogic Technologies, Inc.
 3230 Scott Boulevard, Santa Clara, CA 95054
 Phone (408) 737-4600
 Fax (408) 737-4611



© Advanced Analogic Technologies, Inc. AnalogicTech cannot assume responsibility for use of any circuitry other than circuitry entirely embodied in an AnalogicTech product. No circuit patent licenses, copyrights, mask work rights, or other intellectual property rights are implied. AnalogicTech reserves the right to make changes to their products or specifications or to discontinue any product or service without notice. Except as provided in AnalogicTech's terms and conditions of sale, AnalogicTech assumes no liability whatsoever, and AnalogicTech disclaims any express or implied warranty relating to the sale and/or use of AnalogicTech products including liability or warranties relating to fitness for a particular purpose, merchantability, or infringement of any patent, copyright or other intellectual property right. In order to minimize risks associated with the customer's applications, adequate design and operating safeguards must be provided by the customer to minimize inherent or procedural hazards. Testing and other quality control techniques are utilized to the extent AnalogicTech deems necessary to support this warranty. Specific testing of all parameters of each device is not necessarily performed. AnalogicTech and the AnalogicTech logo are trademarks of Advanced Analogic Technologies Incorporated. All other brand and product names appearing in this document are registered trademarks or trademarks of their respective holders.