

### General Description

The AAT3122 is a low noise, constant frequency charge pump DC/DC converter that uses a dual mode load switch (1X) and fractional (1.5X) conversion to increase efficiency in white LED applications. With input voltages ranging from 2.7V to 5.5V, the device can produce an output current of up to 120mA. A low external parts count (two 1µF flying capacitors and two small bypass capacitors at  $V_{IN}$  and OUT) makes the AAT3122 ideally suited for small battery-powered applications.

AnalogicTech's Simple Serial Control™ (S<sup>2</sup>Cwire™) interface is used to enable, disable, and set the LED drive current with a 32-level logarithmic scale LED brightness control. The AAT3122 has a thermal management system to protect the device in the event of a short-circuit condition on any of the output pins. Built-in soft-start circuitry prevents excessive inrush current during start-up. High switching frequency enables the use of small external capacitors. A low shutdown current feature disconnects the load from  $V_{IN}$  and reduces quiescent current to less than 1µA. The AAT3122 provides a single current source output that can be used to drive up to six LEDs at 20mA each. The AAT3122 is available in a Pb-free TSOPJW-12 package.

### Features

- $V_{IN}$  Range: 2.7V to 5.5V
- <1µA of Shutdown Current
- 1 MHz Switching Frequency
- Dual Mode 1X and 1.5X Charge Pump for Maximum Efficiency
- Only Four External Components
- Simple Serial Control (S<sup>2</sup>Cwire) Interface
- Low Noise Constant Frequency Operation
- 33% Less Input Current Than Doubler Charge Pumps
- Small Application Circuit
- Regulated Output Current
- Automatic Soft Start
- No Inductors
- TSOPJW-12 Package
- -40°C to +85°C Temperature Range

### Applications

- Programmable Current Source
- White LED Backlighting

### Typical Application

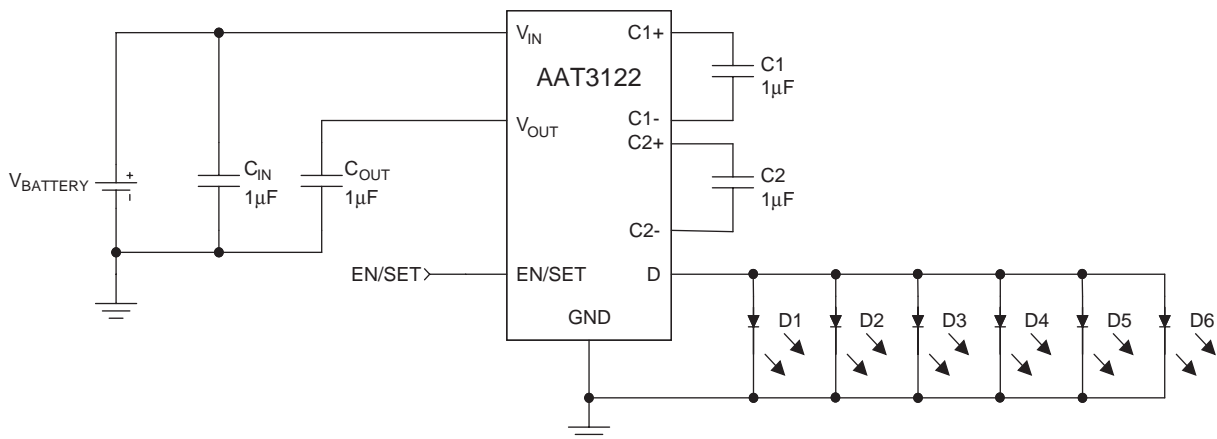

### Pin Descriptions

Pin #	Symbol	Function
1	C2+	Flying capacitor 2 positive terminal. Connect a 1 $\mu$ F capacitor between C2+ and C2-.
2	OUT	Charge pump output. Requires 1 $\mu$ F bypass capacitor to ground.
3	C1-	Flying capacitor 1 negative terminal.
4	C1+	Flying capacitor 1 positive terminal. Connect a 1 $\mu$ F capacitor between C1+ and C1-.
5, 6, 7, 8	D	Output current source with drive capability of up to 120mA.
9	EN/SET	Input control pin. Serial data interface that controls the level of output current. See Application Information for more details.
10	IN	Input power supply. Requires 1 $\mu$ F bypass capacitor to ground.
11	GND	Ground.
12	C2-	Flying capacitor 2 negative terminal.

### Pin Configuration

**TSOPJW-12**  
(Top View)

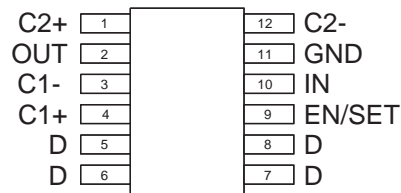

### Absolute Maximum Ratings<sup>1</sup>

Symbol	Description	Value	Units
$V_{IN}$	Input Voltage	-0.3 to 6.0	V
$V_{OUT}$	Charge Pump Output	-0.3 to 6.0	V
$V_{EN/SET}$	EN/SET to GND Voltage	-0.3 to 6.0	V
$V_{EN/SET(MAX)}$	Maximum EN/SET to Input Voltage	0.3	V
$I_{OUT}^2$	Maximum DC Output Current	150	mA
$T_J$	Operating Junction Temperature Range	-40 to 150	°C

### Thermal Information<sup>3</sup>

Symbol	Description	Value	Units
$\Theta_{JA}$	Thermal Resistance	160	°C/W
$P_D$	Maximum Power Dissipation ( $T_A = 25^\circ\text{C}$ ) <sup>4</sup>	625	mW

1. Stresses above those listed in Absolute Maximum Ratings may cause permanent damage to the device. Functional operation at conditions other than the operating conditions specified is not implied. Only one Absolute Maximum Rating should be applied at any one time.
2. Based on long-term current density limitation.
3. Mounted on an FR4 board.
4. Derate 6.25mW/°C above 25°C.

### Electrical Characteristics<sup>1</sup>

$V_{IN} = 3.5V$ ;  $C_{IN} = C_{OUT} = C_1 = C_2 = 1.0\mu F$ ;  $T_A = -40^\circ C$  to  $+85^\circ C$ . Unless otherwise noted, typical values are  $T_A = 25^\circ C$ .

Symbol	Description	Conditions	Min	Typ	Max	Units
<b>Input Power Supply</b>						
$V_{IN}$	Operation Range		2.7		5.5	V
$I_{CC}$	Operating Current	$3.0 \leq V_{IN} \leq 5.5$ , Active, No Load Current		1.8	3.5	mA
$I_{SHDN}$	Shutdown Current	EN = 0			1.0	$\mu A$
$I_D$	Maximum Output Current	$V_{IN} = 3.5V$ ; Code = 32	108	120	132	mA
<b>Charge Pump</b>						
$T_{SS}$	Soft-Start Time			200		$\mu s$
$F_{CLK}$	Clock Frequency			1000		kHz
$\eta_{CP}$	Charge Pump Efficiency	$V_{IN} = 3.6V$ , $I_{OUT(Total)} = 120mA$ ; Measured from IN to OUT		93		%
<b>EN/SET</b>						
$V_{EN(L)}$	Enable Threshold Low	$V_{IN} = 2.7V$ to $5.5V$			0.5	V
$V_{EN(H)}$	Enable Threshold High	$V_{IN} = 2.7V$ to $5.5V$	1.4			V
$T_{LO}$	EN/SET Low Time		0.3		75	$\mu s$
$T_{HI}$	Minimum EN/SET High Time			50		ns
$T_{OFF}$	EN/SET Off Timeout				500	$\mu s$
Input Current	EN/SET Input Leakage		-1.0		1.0	$\mu A$

1. The AAT3122 is guaranteed to meet performance specifications over the  $-40^\circ C$  to  $+85^\circ C$  operating temperature range and is assured by design, characterization, and correlation with statistical process controls.

### Typical Characteristics

Unless otherwise noted,  $V_{IN} = 3.6V$ ,  $C_{IN} = C_{OUT} = C_1 = C_2 = 1\mu F$ ,  $T_A = 25^\circ C$ .

**Efficiency vs.  $V_{IN}$**   
( $I_D = 80mA$ )

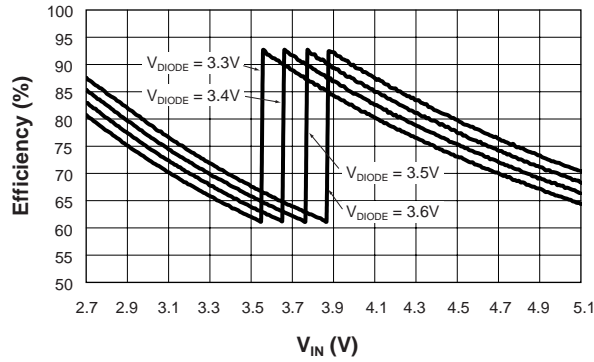

**$I_{DIODE}$  vs.  $V_{IN}$**

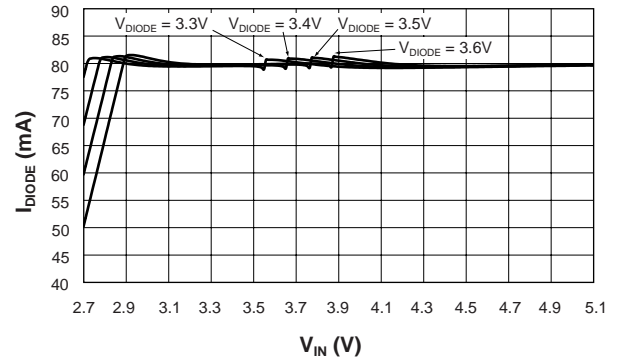

**Quiescent Current vs.  $V_{IN}$**

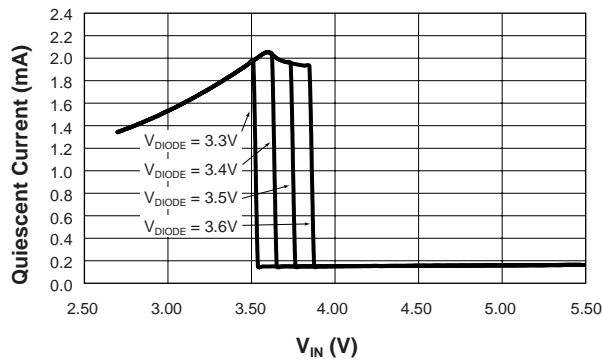

**$V_{IH}$  and  $V_{IL}$  vs.  $V_{IN}$**

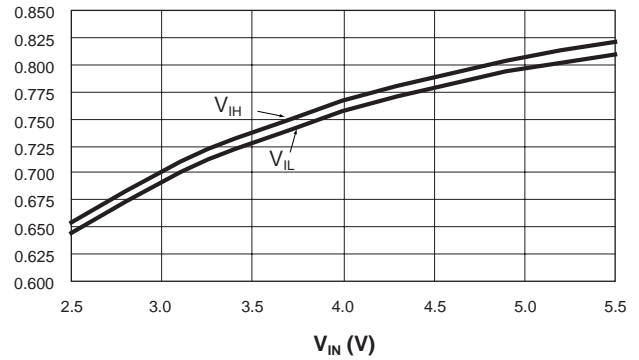

### Typical Characteristics

Unless otherwise noted,  $V_{IN} = 3.6V$ ,  $C_{IN} = C_{OUT} = C_1 = C_2 = 1\mu F$ ,  $T_A = 25^\circ C$ .

Turn-On to Full-Scale Charge Pump

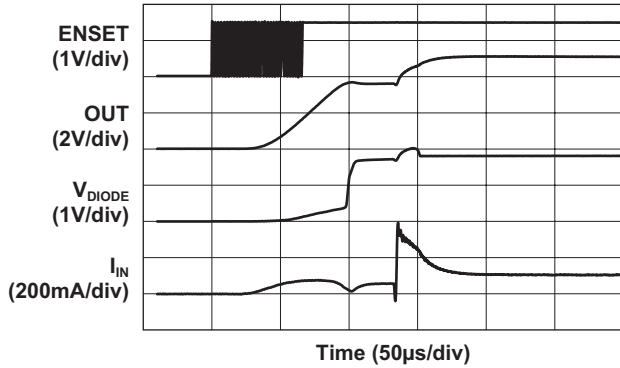

Turn-On to Full-Scale Load Switch

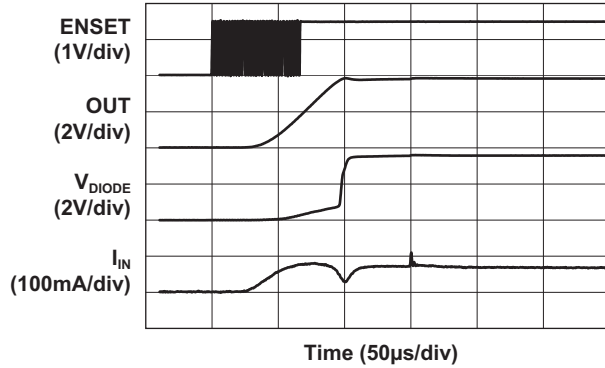

Charge Pump to Load Switch (80mA)

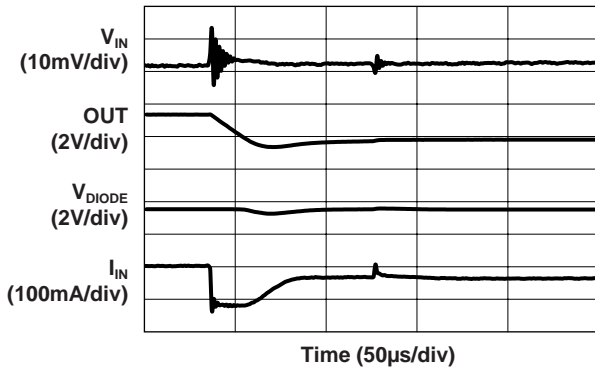

Load Switch to Charge Pump (80mA)

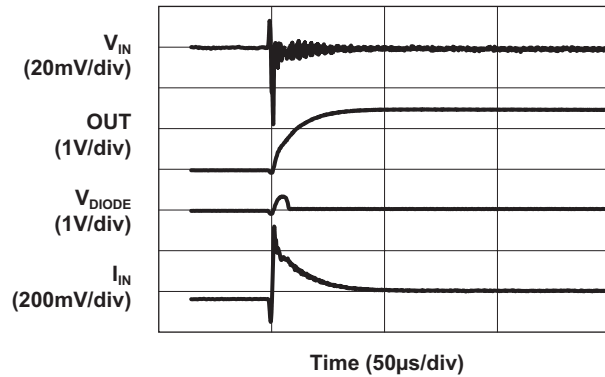

Turn-Off

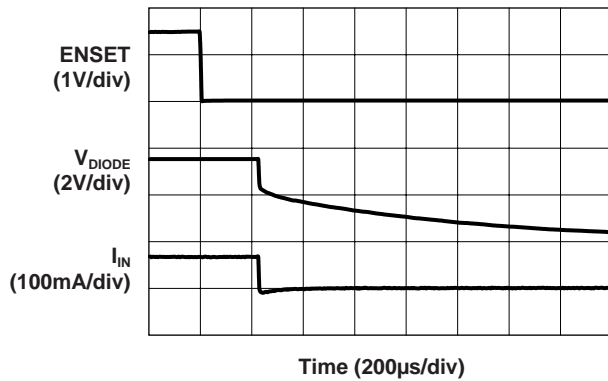

80mA Load Characteristics

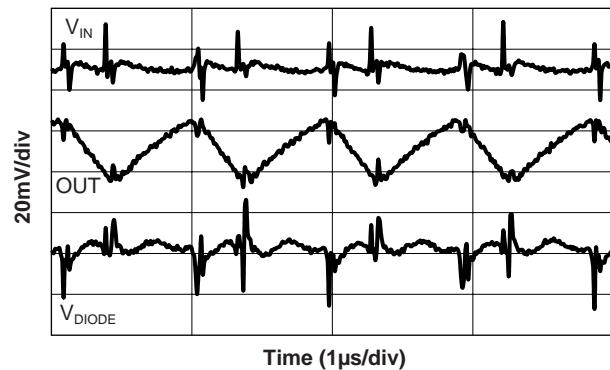

### Functional Block Diagram

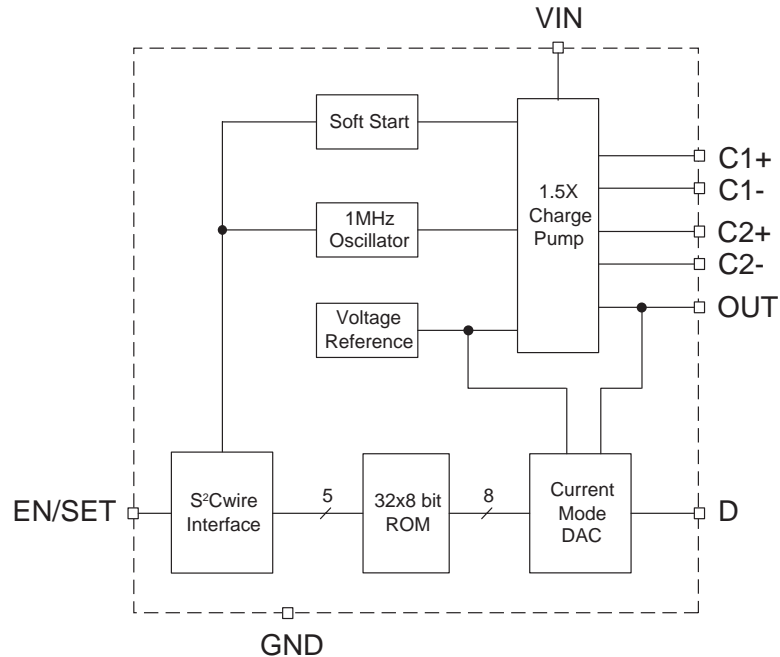

### Functional Description

The AAT3122 is a dual mode load switch (1X) and high efficiency (1.5X) fractional charge pump device intended for white LED backlight applications. The fractional charge pump consists of a low dropout linear voltage regulator followed by a 1.5X charge pump. To maximize power conversion efficiency, an internal feedback control sensing circuit monitors the voltage required on the constant current source output. This control circuit then sets the load switch and charge pump functions based upon the input voltage level versus the output voltage level needed. This function significantly enhances overall device efficiency when the input voltage level is greater than the voltage required at the constant current source output. Switchover between the 1.5X (charge pump) operating mode and the 1X (load switch) mode occurs automatically (as a function of

input and output voltages) and does not require user intervention to maintain maximum efficiency.

The AAT3122 requires only four external components: two  $1\mu\text{F}$  ceramic capacitors for the charge pump flying capacitors ( $C_1$  and  $C_2$ ), one  $1\mu\text{F}$  ceramic capacitor for  $C_{\text{IN}}$ , and one  $0.33\mu\text{F}$  to  $1\mu\text{F}$  ceramic capacitor for  $C_{\text{OUT}}$ . The LDO/1.5X charge pump output is converted into a constant current output capable of driving up to six individual LEDs with a maximum of 20mA each. The current source output magnitude is controlled by the EN/SET serial data S<sup>2</sup>Cwire interface. The interface records rising edges of the EN/SET pin and decodes them into 32 individual current level settings each 1dB apart. This is summarized in Figure 1 and Table 1. Code 32 is full scale, and Code 1 is full scale attenuated by 31dB. The modulo 32 interface wraps states back to State 1 after the 32nd clock.

### Applications Information

#### Current Level Settings

LED current level is set via the serial interface according to a logarithmic scale, where each code is 1dB greater than the previous code. In this manner, the LED brightness appears linear with each increasing code. Table 1 depicts the relationship between each rising edge of the EN/SET and the output current in mA.

Code	I <sub>OUT</sub> (mA)	Code	I <sub>OUT</sub> (mA)
1	3.3	17	21.2
2	3.8	18	24.0
3	4.2	19	26.8
4	4.7	20	30.1
5	5.2	21	33.9
6	6.1	22	38.1
7	6.6	23	42.4
8	7.5	24	47.5
9	8.5	25	53.6
10	9.4	26	60.2
11	10.8	27	67.3
12	11.8	28	75.8
13	13.6	29	84.7
14	15.1	30	95.1
15	16.9	31	106.8
16	18.8	32	120.0

**Table 1: Current Level Settings.**

#### EN/SET Serial Interface

The current source output magnitude is controlled by the EN/SET serial interface. The interface records rising edges of the EN/SET pin and decodes them into 32 individual current level settings each 1dB apart. Code 32 is full scale, and Code 1 is full scale attenuated by 31dB. The modulo 32 interface wraps states back to State 1 after the 32nd clock, so 1dB of attenuation is achieved by clocking the EN/SET pin 31 times. The counter can be clocked at speeds up to 1MHz, so intermediate states are not visible. The first rising edge of EN/SET enables the IC and initially sets the output LED current to 3.3mA, the lowest setting. Once the final clock cycle is input for the desired brightness level, the EN/SET pin is held high to maintain the device output current at the programmed level. The device is disabled 500µs after the EN/SET pin transitions to a logic low state.

The EN/SET timing is designed to accommodate a wide range of data rates. After the first rising edge of EN/SET, the charge pump is enabled and reaches full capacity after the soft-start time (T<sub>SS</sub>). During the soft-start time, multiple clock pulses may be entered on the EN/SET pin to set the final output current level with a single burst of clocks. Alternatively, the EN/SET clock pulses may be entered one at a time to gradually increase the LED brightness over any desired time period. A constant current is sourced as long as EN/SET remains in a logic high state. The current source outputs are switched off after EN/SET has remained in a low state for at least the T<sub>OFF</sub> timeout period.

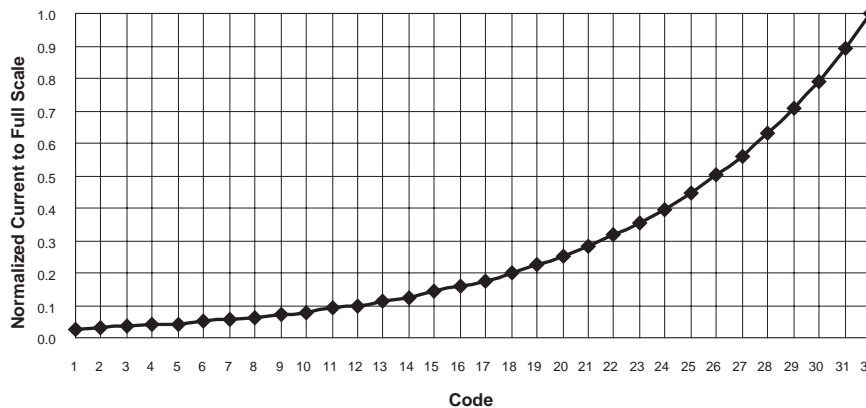

**Figure 1: Normalized Current Level Settings.**



### EN/SET Timing Diagram

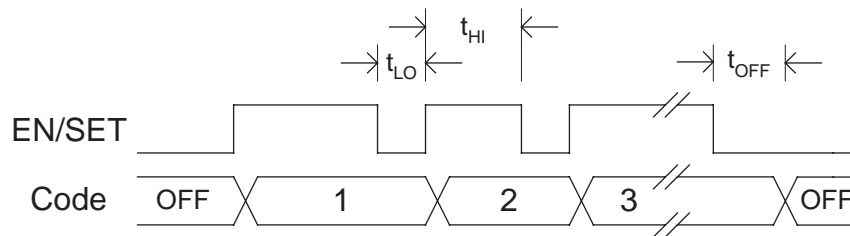

### LED Selection

The AAT3122 is specifically intended for driving white LEDs. However, the device design will allow the AAT3122 to drive most types of LEDs with forward voltage specifications ranging from 2.0V to 4.3V. LED applications may include main and sub-LCD display backlighting, camera photo-flash applications, color (RGB) LEDs, infrared (IR) diodes for remotes, and other loads benefiting from a controlled output current generated from a varying input voltage.

### Device Switching Noise Performance

The AAT3122 operates at a fixed frequency of approximately 1MHz to control noise and limit harmonics that can interfere with the RF operation of cellular telephone handsets or other communication devices. Back-injected noise appearing on the input pin of the charge pump is 20mV peak-to-peak, typically ten times less than inductor-based DC/DC boost converter white LED backlight solutions. The AAT3122 soft-start feature prevents noise transient effects associated with inrush currents during start-up of the charge pump circuit.

### Power Efficiency and Device Evaluation

Due to the unique charge pump circuit architecture and design of the AAT3122, it is very difficult to measure efficiency in terms of a percent value comparing input power over output power.

Since the AAT3122 output is purely a constant current source, it is difficult to measure the output voltage to derive an overall output power measurement. For any given application, white LED forward voltage levels can differ, yet the output drive current will be maintained as a constant.

This makes quantifying output power a difficult task when taken in the context of comparing to other white

LED driver circuit topologies. A better way to quantify total device efficiency is to observe the total input power to the device for a given LED current drive level. The best white LED driver for a given application should be based on trade-offs of size, external component count, reliability, operating range, and total energy usage...*not just % efficiency.*

### Charge Pump Efficiency

The AAT3122 is a fractional charge pump. The efficiency ( $\eta$ ) can be simply defined as a linear voltage regulator with an effective output voltage that is equal to one and a half times the input voltage. Efficiency ( $\eta$ ) for an ideal 1.5X charge pump can typically be expressed as the output power divided by the input power.

$$\eta = \frac{P_{OUT}}{P_{IN}}$$

In addition, with an ideal 1.5X charge pump, the output current may be expressed as 2/3 of the input current. The expression to define the ideal efficiency ( $\eta$ ) can be rewritten as:

$$\eta = \frac{P_{OUT}}{P_{IN}} = (V_{OUT} \times I_{OUT}) / (V_{IN} \times 1.5I_{OUT}) = \frac{V_{OUT}}{1.5V_{IN}}$$

$$\eta(\%) = 100 \left( \frac{V_{OUT}}{1.5V_{IN}} \right)$$

For a charge pump with an output of 5 volts and a nominal input of 3.5 volts, the theoretical efficiency is 95%. Due to internal switching losses and IC quiescent current consumption, the actual efficiency can be measured at 93%. These figures are in close agreement for output load conditions from 3.0mA to 120mA. Efficiency will decrease as load current drops below 0.05mA or when the level of  $V_{IN}$  approaches  $V_{OUT}$ . Refer to the Typical Characteristics section for measured plots of efficiency versus input voltage and output load current for the given charge pump output voltage options.

### Capacitor Selection

Careful selection of the four external capacitors  $C_{IN}$ ,  $C_1$ ,  $C_2$ , and  $C_{OUT}$  is important because they will affect turn-on time, output ripple, and transient performance. Optimum performance will be obtained when low ESR ceramic capacitors are used. In general, low ESR may be defined as less than 100m $\Omega$ . When choosing the four capacitors, a capacitor value of 1 $\mu$ F is a good starting point. If the LED current sources are only programmed for light current levels, then the capacitor size may be decreased.

### Capacitor Characteristics

Ceramic composition capacitors are highly recommended over all other types of capacitors for use with the AAT3122 products. Ceramic capacitors offer many advantages over their tantalum and aluminum electrolytic counterparts. A ceramic capacitor typically has very low ESR, is lowest cost, has a smaller PCB footprint, and is non-polarized. Low ESR ceramic capacitors help maximize charge pump transient response. Since ceramic capacitors are non-polarized, they are not prone to incorrect connection damage.

**Equivalent Series Resistance:** ESR is an important characteristic to consider when selecting a capacitor. ESR is a resistance internal to a capacitor

that is caused by the leads, internal connections, size or area, material composition, and ambient temperature. Capacitor ESR is typically measured in milliohms for ceramic capacitors and can range to more than several ohms for tantalum or aluminum electrolytic capacitors.

**Ceramic Capacitor Materials:** Ceramic capacitors less than 0.1 $\mu$ F are typically made from NPO or COG materials. NPO and COG materials typically have tight tolerance and are stable over temperature. Large capacitor values are typically composed of X7R, X5R, Z5U, or Y5V dielectric materials. Large ceramic capacitors, typically greater than 2.2 $\mu$ F, are often available in low-cost Y5V and Z5U dielectrics, but large capacitors are not required in the AAT3122 application.

Capacitor area is another contributor to ESR. Capacitors that are physically large will have a lower ESR when compared to an equivalent material smaller capacitor. These larger devices can improve circuit transient response when compared to an equal value capacitor in a smaller package size.

### Thermal Protection

The AAT3122 has a thermal protection circuit that will shut down the charge pump and current outputs if the die temperature rises above the thermal limit due to short-circuit conditions.

### Additional Application Circuit

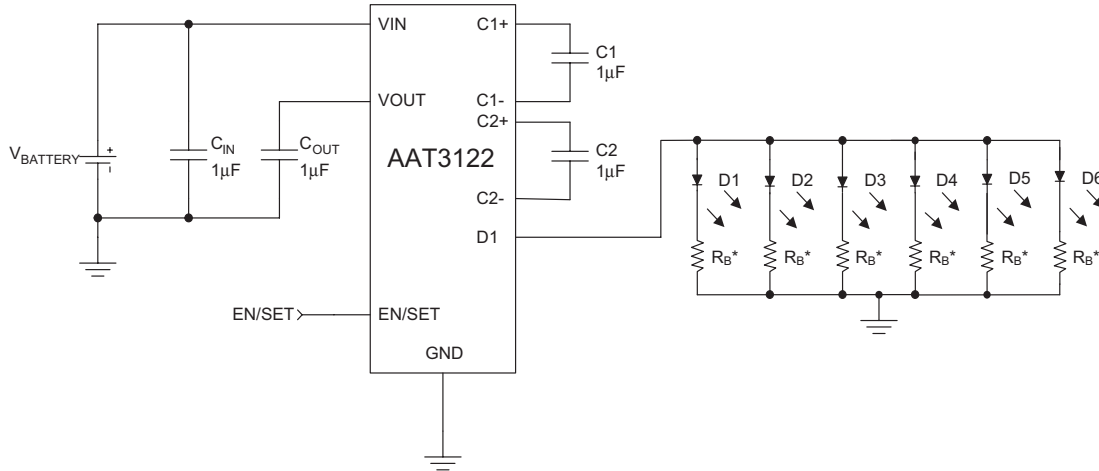

\*In some applications, white LED forward voltages ( $V_F$ ) can vary significantly. Ballast resistors between the LED cathodes and ground are recommended for balancing the forward voltage differences. The ballast resistor value may be approximated by the following equation:

$$R_B = \frac{(V_{IN(MIN)})1.5 - (V_{F(MAX)} + 250mV)}{I_{F(MAX)}}$$

$V_{F(MAX)}$  = Maximum expected LED forward voltage at the given maximum forward current level. Refer to the LED manufacturers' datasheet for maximum  $V_F$  specifications.

$I_{F(MAX)}$  = Maximum forward current used to drive an individual LED.

$V_{IN(MIN)}$  = Minimum input supply voltage for the application.

$R_B$  = Ballast resistor value in ohms.

### Ordering Information

Package	Marking <sup>1</sup>	Part Number (Tape and Reel) <sup>2</sup>
TSOPJW-12	JEXYY	AAT3122ITP-T1



All AnalogicTech products are offered in Pb-free packaging. The term “Pb-free” means semiconductor products that are in compliance with current RoHS standards, including the requirement that lead not exceed 0.1% by weight in homogeneous materials. For more information, please visit our website at <http://www.analogictech.com/pbfree>.

### Package Information

#### TSOPJW-12

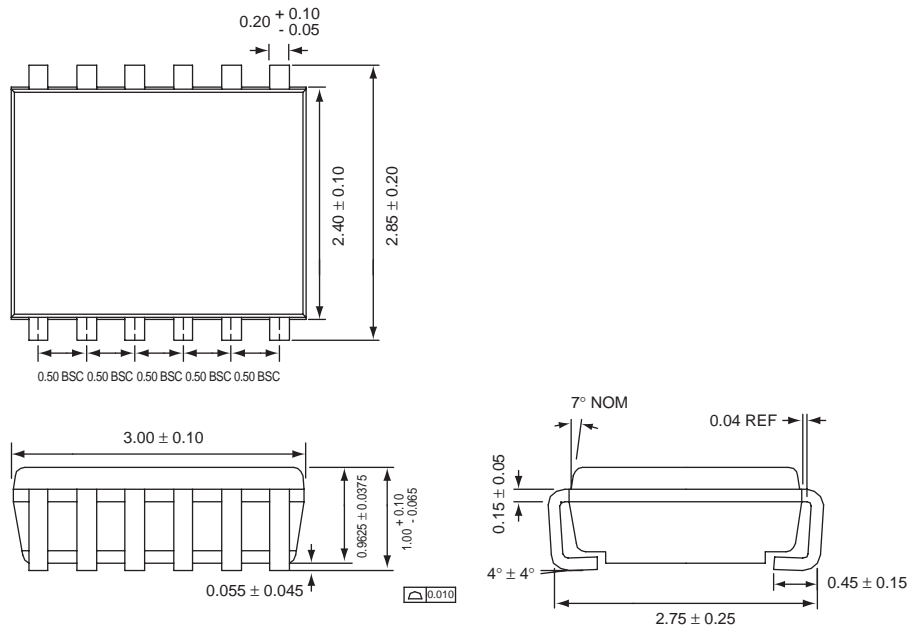

All dimensions in millimeters.

1. XXX = assembly and date code.
2. Sample stock is generally held on part numbers listed in **BOLD**.

© Advanced Analogic Technologies, Inc.

AnalogicTech cannot assume responsibility for use of any circuitry other than circuitry entirely embodied in an AnalogicTech product. No circuit patent licenses, copyrights, mask work rights, or other intellectual property rights are implied. AnalogicTech reserves the right to make changes to their products or specifications or to discontinue any product or service without notice. Customers are advised to obtain the latest version of relevant information to verify, before placing orders, that information being relied on is current and complete. All products are sold subject to the terms and conditions of sale supplied at the time of order acknowledgement, including those pertaining to warranty, patent infringement, and limitation of liability. AnalogicTech warrants performance of its semiconductor products to the specifications applicable at the time of sale in accordance with AnalogicTech's standard warranty. Testing and other quality control techniques are utilized to the extent AnalogicTech deems necessary to support this warranty. Specific testing of all parameters of each device is not necessarily performed.

**Advanced Analogic Technologies, Inc.**  
 830 E. Arques Avenue, Sunnyvale, CA 94085  
 Phone (408) 737-4600  
 Fax (408) 737-4611