

General Description

The AAT3103 is a constant frequency charge-pump based current-source white LED driver capable of driving one to three LEDs up to 30mA, each. The charge pumps automatically switch between 1x mode and 2x mode to maintain the highest efficiency and optimal LED current accuracy and matching. A low external parts count (one $1\mu\text{F}$ flying capacitor, two small $1\mu\text{F}$ capacitors at IN and OUT and one current setting resistor) makes the AAT3103 ideally suited for small battery-powered applications.

The AAT3103-1/-2 uses AnalogicTech's Simple Serial Control™ (S²Cwire™) interface to enable, disable, and program the LED driving current. The AAT3103-4 employs a Pulse Width Modulation (PWM) signal with up to 50kHz frequency, 10% to 100% duty cycle to program the LED current. A low-current shutdown feature disconnects the load from IN and reduces quiescent current to less than $1\mu\text{A}$. Built-in soft-start circuitry prevents excessive inrush current during start-up. Integrated short circuit and thermal protection circuitry protects the device from damage.

The AAT3103 is available in a 2x2.1mm thermally enhanced Pb-free 10-lead SC70JW-10 package.

Features

- Source WLED Driver, up to 3 LEDs at up to 30mA, each
- Automatic Switching Between 1x and 2x Modes
- 900KHz Switching Frequency
- Linear LED Output Current Control
 - Single-wire, S²Cwire Interface
 - AAT3103-1: 16-step
 - AAT3103-2: 8-step
 - ON/OFF or PWM Interface
 - AAT3103-4
- $\pm 10\%$ LED Output Current Accuracy
- $\pm 3\%$ LED Output Current Matching
- Low-current Shutdown Mode
- Built-in Short Circuit and Thermal Protection
- Automatic Soft-start
- 2x2.1mm SC70JW-10 Package

Applications

- Cordless Phone Handsets
- Mobile Phone Handsets
- MP3 and PMP Players
- Digital Cameras

Typical Application

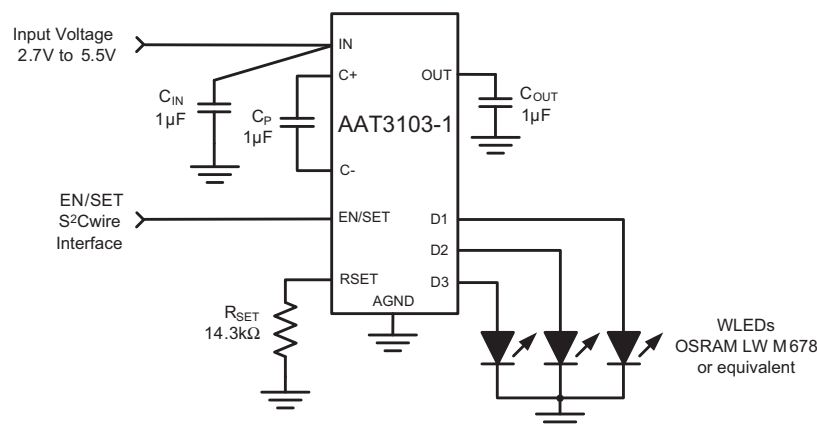

Pin Descriptions

Pin #	Symbol	Description
1	D1	LED1 Current Source Output. Connect LED1's anode to D1 and its cathode to AGND.
2	OUT	Charge Pump Output. Bypass OUT to AGND with a 1 μ F or larger ceramic capacitor.
3	C-	Charge Pump Capacitor Negative Node.
4	C+	Charge Pump Capacitor Positive Node. Connect a 1 μ F ceramic capacitor between C+ and C-.
5	IN	Power source input. Connect IN to the power source, typically the battery. Bypass IN to AGND with a 1 μ F or larger ceramic capacitor.
6	EN/SET (AAT3103-1/-2)	LED Enable and serial control input. EN/SET is the ON/OFF control for the LED and the S ² Cwire digital input for the AAT3103-1/-2 to control the LED brightness up to the maximum current set by R _{SET} .
	EN/PWM (AAT3103-4)	LED ON/OFF and PWM (Pulse Width Modulation) control input. This logic input controls the LED outputs for the AAT3103-4. A PWM signal, ranging from 10% to 100% duty cycle, controls the LED current linearly between minimum and the full-scale output set by R _{SET} .
7	RSET	A 1% tolerance resistor from this pin to AGND sets the maximum LED current value. For optimal LED output current accuracy and matching in the AAT3103-1/-2/-4, a 14.3k Ω resistor sets each full-scale output current to 20mA.
8	AGND	Analog Ground. Connect this pin to the system's analog ground plane.
9	D3	LED3 Current Source Output. Connect LED3's anode to D3 and its cathode to AGND.
10	D2	LED2 Current Source Output. Connect LED2's anode to D2 and its cathode to AGND.

Pin Configuration

**SC70JW-10
(Top View)**

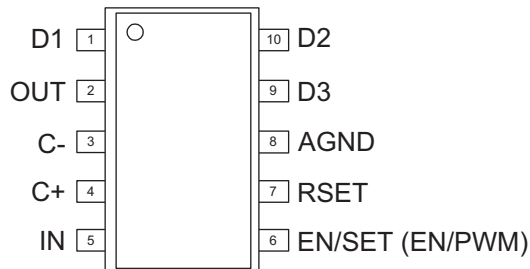

Absolute Maximum Ratings¹

Symbol	Description	Value	Units
	IN, C+, C-, OUT, D1, D2, D3, and R _{SET} Pin Voltages to AGND	-0.3 to 6.0	V
	EN/SET or EN/PWM Pin Voltage to AGND	-0.3 to V _{IN} + 0.3	V
T _J	Operating Junction Temperature Range	-40 to 150	°C
T _{LEAD}	Maximum Soldering Temperature (at leads, 10 sec)	300	°C

Thermal Information

Symbol	Description	Value	Units
P _D	Maximum Power Dissipation ^{2, 3}	625	mW
θ _{JA}	Maximum Thermal Resistance ²	160	°C/W

1. Stresses above those listed in Absolute Maximum Ratings may cause permanent damage to the device. Functional operation at conditions other than the operating conditions specified is not implied. Only one Absolute Maximum Rating should be applied at any one time.

2. Mounted on an FR4 circuit board.

3. Derate 6.25mW/°C above 40 °C ambient temperature.

Electrical Characteristics¹

IN = EN = 3.6V; C_{IN} = 1μF; C_{OUT} = 1μF; C_{CP} = 1μF; R_{SET} = 14.3kΩ; T_A = -40°C to 85°C unless otherwise noted. Typical values are at T_A = 25°C.

Symbol	Description	Conditions	Min	Typ	Max	Units
Input Power Supply						
IN	Input Voltage Range		2.7		5.5	V
I _{IN}	Input Operating Current	IN = 5.5V; EN = IN; V _{D1} = V _{D2} = V _{D3} = 0V		7.4	10	mA
		IN = 5.5V; EN = IN; I _{D1} = I _{D2} = I _{D3} = FS, excluding I _{D1} -I _{D3} ; V _{D1} = V _{D2} = V _{D3} = IN - 1.5V		1.9	3	
		Operating, I _{D1} = I _{D2} = I _{D3} = OPEN		4	6.8	
I _{IN(SHDN)}	Input Shutdown Current	EN/SET or EN/PWM = GND			1	μA
Charge Pump Section						
I _{OUT}	OUT Maximum Output Current			100		mA
f _{OSC}	Charge Pump Oscillator Frequency		0.65	0.9	1.4	MHz
V _{IN(TH)}	Charge Pump Mode Hysteresis	I _{D1} = I _{D2} = I _{D3} = 20mA		325		mV
t _{OUT}	LED Output Current Start-up Time	EN/SET or EN/PWM = IN		150		μs
AAT3103-1/-2/-4: LED Current Source Outputs						
I _{D(MAX)}	D1 - D3 Current Accuracy	DATA = 1; V _{IN} - V _F = 1.5V.	18	20	22	mA
ΔI _{D(MAX)}	D1 - D3 Current Matching	DATA = 1; V _{IN} - V _F = 1.5V		±3		%
I _{D(DATA15)}	D1 - D3 Current Accuracy (AAT3103-1 only)	DATA = 15; V _{IN} - V _F = 1.5V	1.0	1.34	1.61	mA
I _{D(DATA8)}	D1 - D3 Current Accuracy (AAT3103-2 only)	DATA = 8; V _{IN} - V _F = 1.5V	1.0	1.34	1.61	mA
I _{D(10%)}	D1 - D3 Current Accuracy (AAT3103-4 only)	DC = 10%; V _{IN} - V _F = 1.5V		2.5		mA
V _{D(TH)}	D1- D3 Charge Pump Mode Transition Threshold	I _{D1} = I _{D2} = I _{D3} = 20mA		280		mV
V _{SET}	R _{SET} Pin Voltage		1.14	1.18	1.22	V
AAT3103-1/-2: EN/SET and S²Cwire Control						
V _{ENH}	EN/SET Input High Threshold Voltage		1.4			V
V _{ENL}	EN/SET Input Low Threshold Voltage				0.4	V
I _{EN(LKG)}	EN/SET Input Leakage Current	EN/SET = IN = 5V	-1		1	μA
t _{EN/SET(OFF)}	EN/SET Input OFF Timeout				500	μs
t _{EN/SET(LAT)}	EN/SET Input Latch Timeout				500	μs
t _{EN/SET(LOW)}	EN/SET Input Low Time		0.3		75	μs
t _{ENSET(H-MIN)}	EN/SET Minimum High Time			50		ns
t _{ENSET(H-MAX)}	EN/SET Maximum High Time				75	μs
AAT3103-4: EN/PWM Current Control						
V _{ENH}	EN/PWM Input High Threshold Voltage		1.4			V
V _{ENL}	EN/PWM Input Low Threshold Voltage				0.4	V
I _{EN(LKG)}	EN/PWM Input Leakage Current	EN/PWM = IN = 5V	-1		1	μA
t _{PWM(ON)}	PWM Control Turn-on Delay			110		μs
t _{EN/PWM}	EN/PWM Input OFF Timeout		0.15		1	ms
f _{PWM}	PWM Control Frequency	Duty cycle = 80%			50	kHz

1. The AAT3103 is guaranteed to meet performance specifications over the -40°C to 85°C operating temperature range and is assured by design, characterization and correlation with statistical process controls.

Typical Characteristics

Shutdown Current vs. Temperature

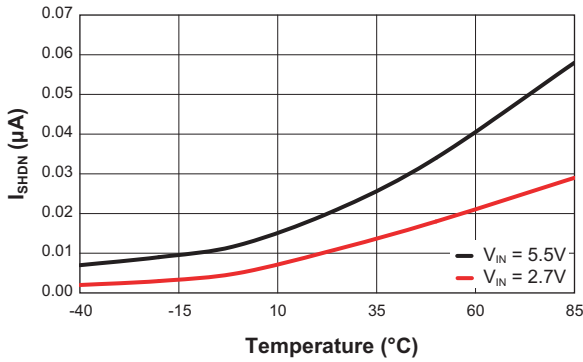

Operating Current vs. Input Voltage
($V_{D1} = V_{D2} = V_{D3} = 0V$)

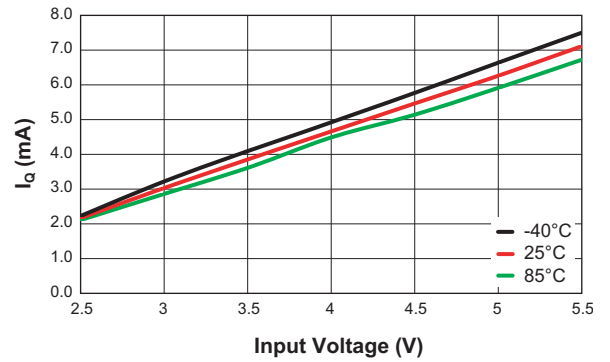

Operating Current vs. Input Voltage
(No Load; D1, D2, D3 Open)

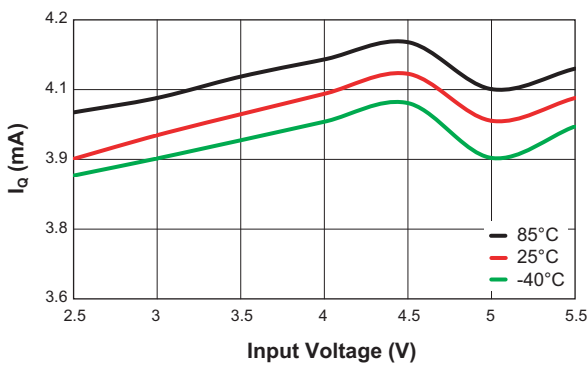

LED Current Matching vs. Temperature

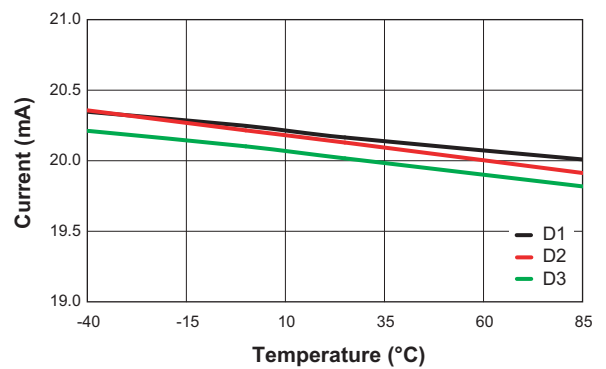

Efficiency vs. Input Voltage

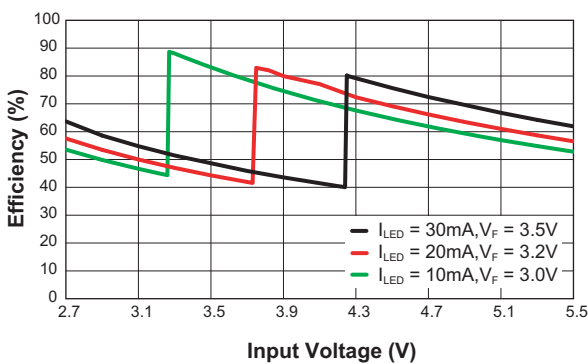

I_LED Full Scale vs. R_SET

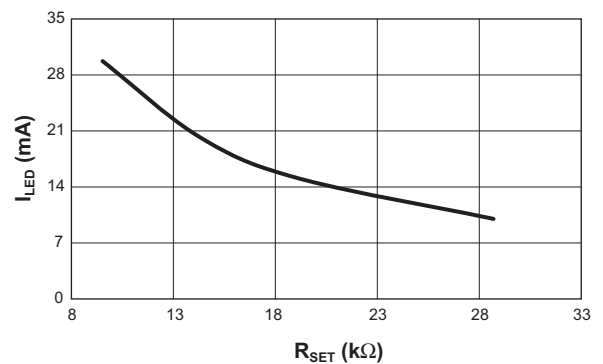

Typical Characteristics

EN Input High Threshold Voltage vs. Input Voltage

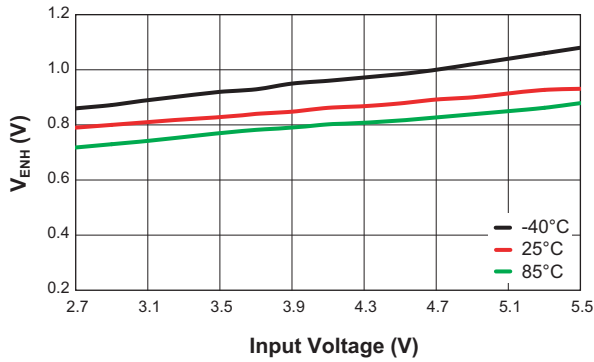

EN Input Low Threshold Voltage vs. Input Voltage

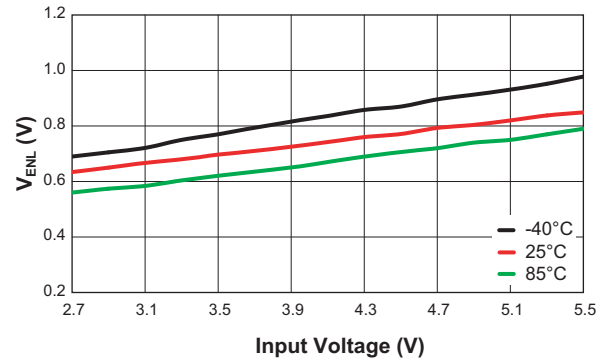

EN/SET Input Latch Timeout vs. Input Voltage

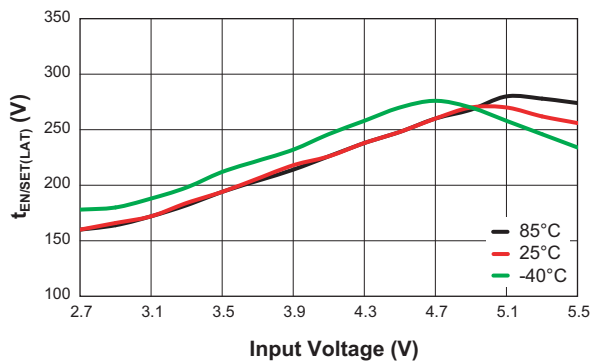

EN/SET Input Off Timeout vs. Input Voltage

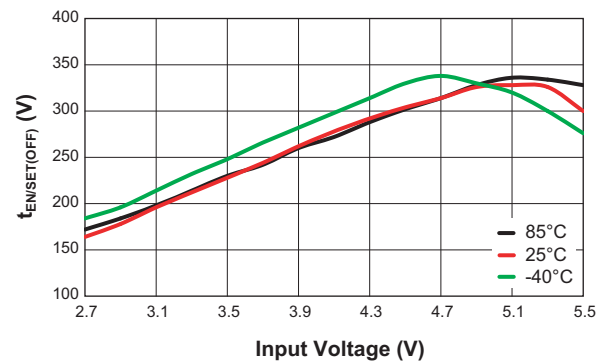

**Turn-On to 2X Mode
(V_{IN} = 3.6V; 20mA/Dx)**

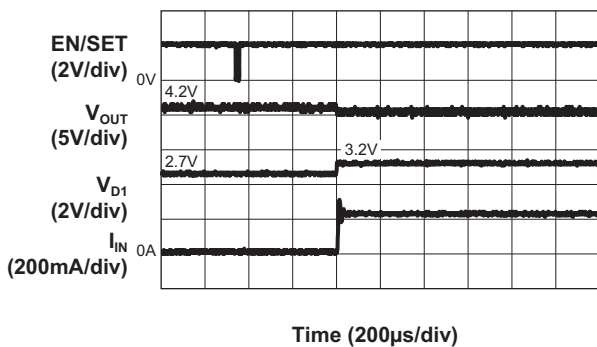

**Turn-Off from 2X Mode
(V_{IN} = 3.6V; 20mA/Dx)**

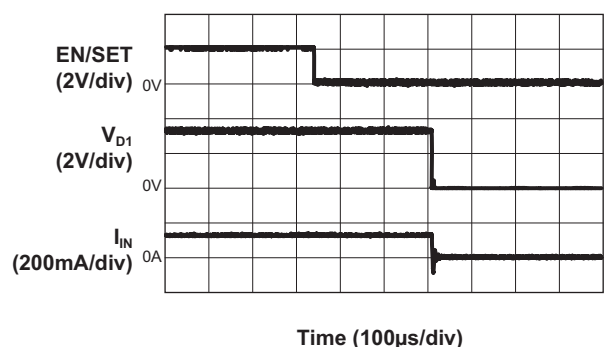

Typical Characteristics

Turn-On to 1X Mode
($V_{IN} = 4.2V$; 20mA/Dx)

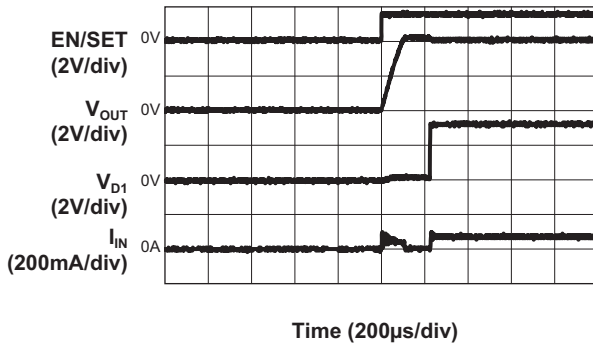

Output Ripple Waveform
(2X Mode; 20mA/Dx)

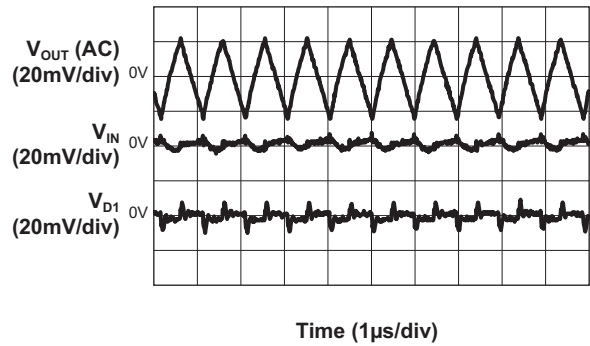

LED Current Transition
($V_{IN} = 4.2V$; 1.3mA to 20mA)

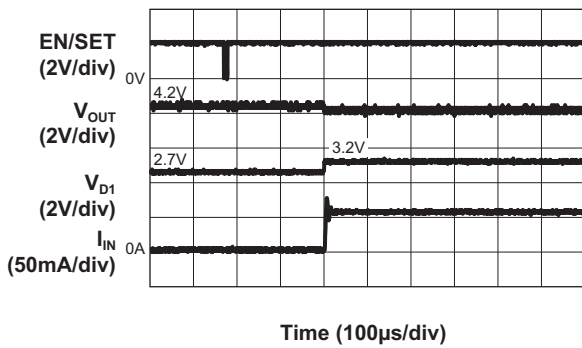

LED Current Transition
($V_{IN} = 4.2V$; 20mA to 1.3mA)

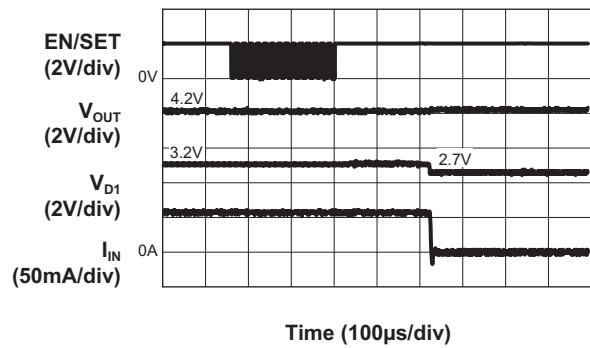

Input Current vs. Input Voltage

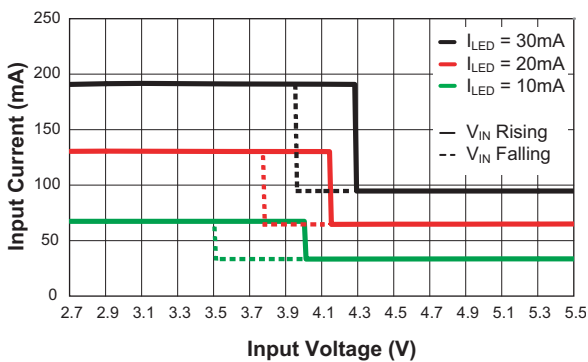

Functional Block Diagram

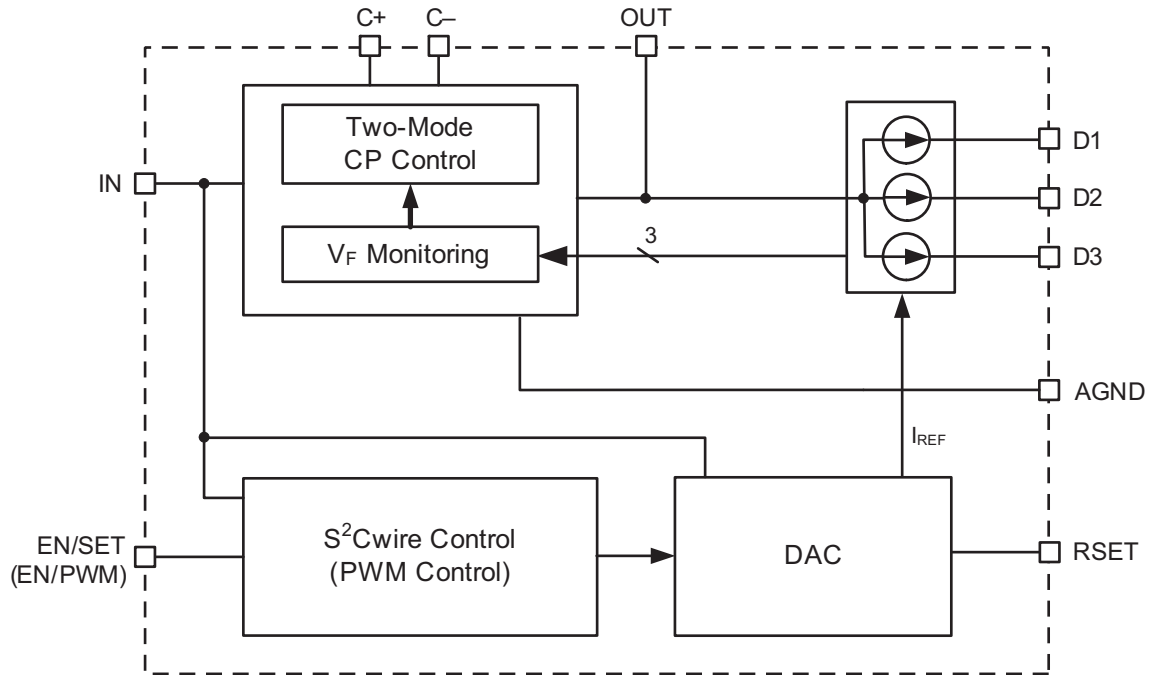

Functional Description

The AAT3103 is a low-cost charge-pump solution designed to drive up to three WLEDs. The charge pump operates from a 2.7V to 5.5V power source and converts it to voltage levels necessary to drive the LEDs. LED current is individually controlled through integrated current sources powered from the output of the charge pump. Low 1x charge-pump output resistance and low-drop voltage current sources allow the charge pump to stay in 1x mode with an input voltage as low as 3.75V and LED forward voltages as high as 3.2V with 20mA LED current. Once in 2x mode, the charge pump monitors the input supply voltage and automatically switches back to 1x mode when there is sufficient input voltage.

The AAT3103 requires only four external components: one 1 μ F ceramic capacitor for the charge pump flying capacitors (C_P), one 1 μ F ceramic input capacitor (C_{IN}), one 1 μ F ceramic output capacitor (C_{OUT}) and a resistor

(R_{SET}) to set the maximum LED current. The three constant current outputs of the AAT3103 (D1 to D3) can drive three individual LEDs with a maximum current of 30mA each. AnalogicTech's S²Cwire serial interface enables the AAT3103-1/-2 and changes the current source magnitudes through the EN/SET pin. The AAT3103-4 uses an external PWM signal to enable the IC and control the brightness of the LEDs.

Constant Current Control Using R_{SET}

The maximum current is programmed by an external resistor at the RSET pin. With a 14.3k Ω external resistor at the RSET pin, the AAT3103 includes an integrated serial LED current control that sets the full-scale LED current between 20mA and 0.67mA. The full-scale LED current can be set higher or lower than 20mA; see Table 4. For maximum accuracy, a 1% tolerance resistor is recommended.

Part Number Descriptions

Part Number	Interface	Current Control, Inverting
AAT3103IJQ-1	S ² Cwire	16-step
AAT3103IJQ-2	S ² Cwire	8-step
AAT3103IJQ-4	PWM	Linear

S²Cwire Serial Interface (AAT3103-1/-2 only)

The LED output current of the AAT3103-1/-2 is controlled by AnalogicTech's S²Cwire serial interface. Since the LED current is programmable, no PWM or additional control circuitry is needed to control the LED brightness. This feature greatly reduces the burden on a microcontroller or system IC to manage LED or display brightness, allowing the user to "set it and forget it." With its high-speed serial interface (1MHz data rate), the LED current can be

changed quickly and easily. Also the non-pulsating LED current reduces system noise and improves LED reliability. The S²Cwire interface relies on the number of rising edges to the EN/SET pin to set the register. A typical write protocol is a burst of EN/SET rising edges, followed by a pause with EN/SET held high for at least t_{LAT} (500µs). The programmed current is then seen at the current source outputs. When EN/SET is held low for an amount of time longer than t_{OFF} (500µs), the AAT3103 enters into shutdown mode and draws less than 1µA from the input and the internal data register is reset to zero.

The AAT3103-1/-2's serial interface reduces the LED current on each rising pulse of the enable input. If the AAT3103 is in shutdown, the first rising edge of the EN/SET input turns on the LED driver to the maximum current. Successive rising edges decrease the LED current as shown in Table 1 and Figure 2 for the AAT3103-1. For the AAT3103-2, Table 2 and Figure 3 illustrate an 8-step LED current control profile.

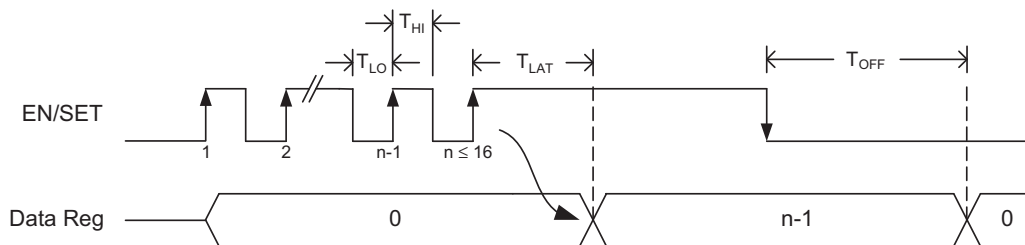

Figure 1: S²Cwire Serial Interface Timing.

S ² C Data	EN Rising Edges	D1-D3 Current (mA)
1	1	20.1
2	2	18.8
3	3	17.5
4	4	16.1
5	5	14.8
6	6	13.4
7	7	12.1
8	8	10.7
9	9	9.4
10	10	8.1
11	11	6.7
12	12	5.4
13	13	4.0
14	14	2.7
15	15	1.34
16	16	0.67

Table 1: AAT3103-1 LED Current Settings, $R_{SET} = 14.3k\Omega$.

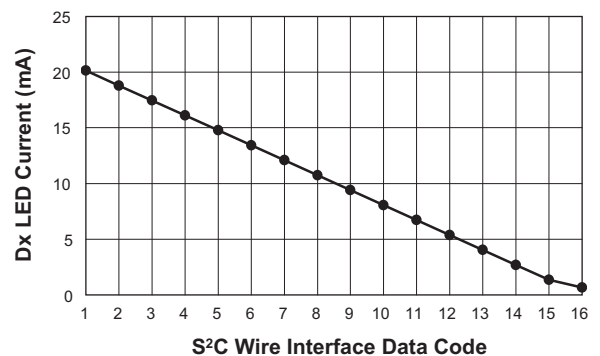

Figure 2: AAT3103-1 Current Control Profile, $R_{SET} = 14.3k\Omega$.

Data	EN Rising Edges	D1-D3 Current (mA)
1	1	20.1
2	2	17.5
3	3	14.8
4	4	12.1
5	5	9.4
6	6	6.7
7	7	4.0
8	8	1.34

Table 2: AAT3103-2 LED Current Settings,
 $R_{SET} = 14.3k\Omega$.

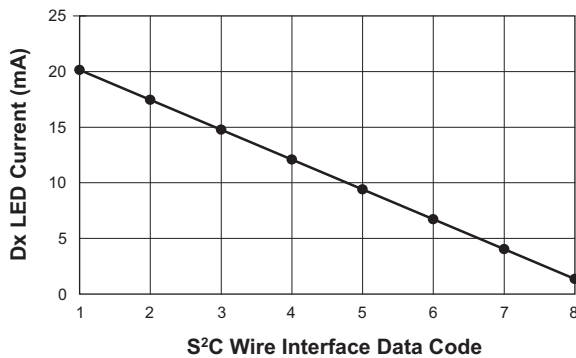

Figure 3: AAT3103-2 Current Control Profile,
 $R_{SET} = 14.3k\Omega$.

PWM Control (AAT3103-4 only)

PWM (Pulse Width Modulation) is a technique of controlling LED brightness by modulating the conduction duty cycle of the LED current. LED brightness is determined by the PWM duty cycle and FS (Full Scale) and LSB (the least LED current). The FS LED current is determined by R_{SET} . The LSB LED current value is equal to the FS value divided by 30. A PWM control signal can be applied into the EN/PWM pin of the AAT3103-4. By changing the duty

cycle of the PWM signal from 100% (logic high) to 10%, the LED current can be programmed from 20mA to 2.6mA. To save power when not used, the AAT3103-4 can be shut down by holding the EN/PWM pin low for 500µs.

Lastly, Table 3 and Figure 4 illustrate the AAT3103-4's LED current control profile as a function of a PWM control signal.

EN/PWM Duty Cycle	D1-D3 Current (mA)
100%	20.2
90%	18.2
80%	16.2
70%	14.3
60%	12.3
50%	10.4
40%	8.5
30%	6.55
20%	4.6
10%	2.6

Table 3: AAT3103-4 LED Current Settings,
 $R_{SET} = 14.3k\Omega$, $f_{PWM} = 25kHz$.

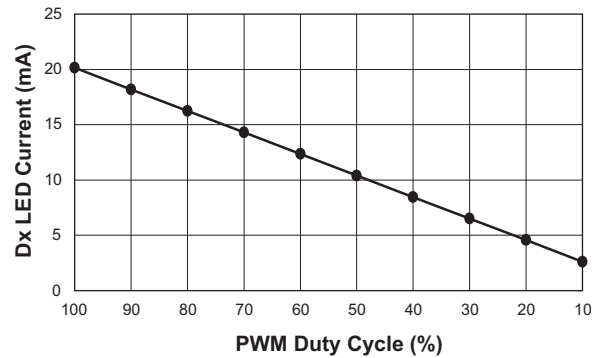

Figure 4: AAT3103-4 Current Control Profile,
 $R_{SET} = 14.3k\Omega$, $f_{PWM} = 25kHz$.

Applications Information

LED Selection

The AAT3103 is specifically intended for driving WLEDs. However, the device design will allow the AAT3103 to drive most types of LEDs with forward voltage specifications ranging from 2.2V to 4.7V. LED applications may include mixed arrangements for display backlighting, keypad display, and any other application needing a constant current sink generated from a varying input voltage. Since the D1 to D3 constant current sources are matched with negligible supply voltage dependence, the constant current channels will be matched regardless of the specific LED forward voltage (V_f) levels.

The internal charge pump and low dropout current sources in the AAT3103 maximize performance and make it capable of driving LEDs with high forward voltages. Multiple channels can be combined to obtain a higher LED drive current without complication.

Constant Current Setting

The LED full scale current is controlled by the R_{SET} resistor. The following formula can be used to calculate the AAT3103-1/2/4 full scale LED current:

$$I_{LED_FS} = \frac{1.2}{R_{SET}} \cdot 4 \cdot 60$$

Table 4 shows the R_{SET} resistor value for the AAT3103-1/2/4 for various LED full-scale current levels. For maximum accuracy, a 1% tolerance resistor is recommended.

I_{LED_FS} (mA)	R_{SET} (k Ω)
30.2	9.53
20.1	14.3
15.1	19.1
10.0	28.7

Table 4: Maximum LED Current and R_{SET} Resistor Values (1% Resistor Tolerance) for the AAT3103.

The S²C interface rising edges control the LED current from full scale to the LSB. For the AAT3103-1, 16 steps are employed. Figure 5 shows the LED current of the AAT3103-1 at different R_{SET} values.

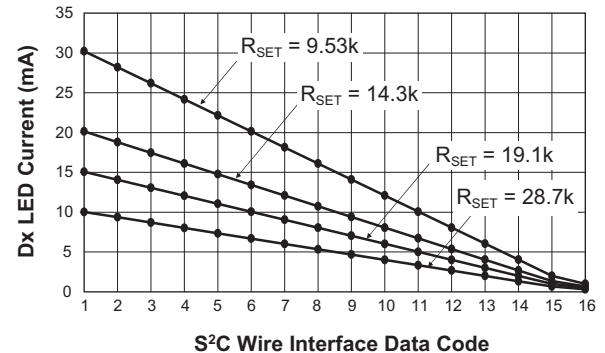

Figure 5: AAT3103-1 LED Current Control Profile at Different R_{SET} Values.

Use the following formula to calculate the AAT3103-3 full scale LED current:

$$I_{LED_FS} = \frac{1.2}{R_{SET}} \cdot 4 \cdot 48$$

For example, an 11.5k Ω 1% resistor is used to achieve 20mA full scale LED current operation.

Device Switching Noise Performance

The AAT3103 operates at a fixed frequency of approximately 0.9MHz to control noise and limit harmonics that can interfere with the RF operation of mobile communication devices. Back-injected noise appearing on the input pin of the charge pump is 20mV peak-to-peak, typically ten times less than inductor-based DC/DC boost converter WLED backlight solutions. The AAT3103's soft-start feature prevents noise transient effects associated with inrush currents during start-up of the charge pump circuit.

Shutdown

To activate the shutdown operation, the EN/SET input for the AAT3103-1/-2 should be pulsed low for longer than t_{OFF} (500 μ s). For the 3103-4 PWM options, shutdown operation is enabled when the EN/PWM input is pulsed low longer than 500 μ s. In this state, the AAT3103 typically draws less than 1 μ A from the input. Registers are reset to 0 in shutdown.

Power Efficiency and Device Evaluation

The charge pump efficiency discussion in the following sections accounts only for efficiency of the charge pump section itself. Due to the unique circuit architecture and design of the AAT3103, it is very difficult to measure efficiency in terms of a percent value comparing input power over output power.

Since the AAT3103 outputs are pure constant current sources and typically drive individual loads, it is difficult to measure the output voltage for a given output pin to derive an overall output power measurement. For any given application, WLED forward voltage levels can differ, yet the output drive current will be maintained as a constant.

This makes quantifying output power a difficult task when taken in the context of comparing to other WLED driver circuit topologies. A better way to quantify total device efficiency is to observe the total input power to the device for a given LED current drive level. The best WLED driver for a given application should be based on trade-offs of size, external component count, reliability, operating range, and total energy usage...*not just % efficiency.*

The AAT3103 efficiency may be quantified under very specific conditions and is dependent upon the input voltage versus the outputs of D1, D2 and D3 for a given constant current setting. Depending on the combination of V_{IN} and voltages sensed at the current sources, the device will operate in load switch mode. When any one of the voltages sensed at the current sources nears drop-out, the device will operate in 2x charge pump mode.

Each of these modes will yield different efficiency values. Refer to the following two sections for explanations for each operational mode.

1x Mode Efficiency

The AAT3103 1x mode is operational at all times and functions alone to enhance device power conversion efficiency when V_{IN} is higher than the voltage across the load. When in 1x mode, voltage conversion efficiency is defined as output power divided by input power.

$$\eta = \frac{P_F}{P_{IN}}$$

The ideal efficiency (η) in 1x charge-pump mode can be expressed as:

$$\eta = \frac{P_{OUT}}{P_{IN}} = \frac{V_F \cdot I_{LED}}{V_{IN} \cdot I_{IN}} = \frac{V_F \cdot I_{LED}}{V_{IN} \cdot I_{OUT}} \approx \frac{V_F}{V_{IN}}$$

-or-

$$\eta (\%) = \frac{V_F}{V_{IN}} \cdot 100$$

For a charge pump LED driver with V_F of 3.2V and 4.2V input voltage, the theoretical efficiency is 76%. Due to internal switching losses and IC quiescent current consumption, the actual efficiency can be measured at 73%.

2x Charge Pump Mode Efficiency

The AAT3103 contains a charge pump which will boost the input supply voltage in the event where V_{IN} is less than the voltage required to supply the output. The efficiency (η) can be simply defined as a linear voltage regulator with an effective output voltage that is equal to one half of the input voltage. Efficiency (η) for an ideal 2x charge pump can typically be expressed as the output power divided by the input power.

$$\eta = \frac{P_F}{P_{IN}}$$

In addition, with an ideal 2x charge pump, the output current may be expressed as 1/3 of the input current. The expression to define the ideal efficiency (η) can be rewritten as

$$\eta = \frac{P_{OUT}}{P_{IN}} = \frac{V_F \cdot I_{LED}}{V_{IN} \cdot I_{IN}} = \frac{V_F \cdot I_{LED}}{V_{IN} \cdot 2 \cdot I_{OUT}} \approx \frac{V_F}{2 \cdot V_{IN}}$$

-or-

$$\eta (\%) = \frac{V_F}{2 \cdot V_{IN}} \cdot 100$$

For a charge pump LED current source driver with V_F of 3.2V and 2.7V input voltage, the theoretical efficiency is 59%. Due to internal switching losses and IC quiescent current consumption, the actual efficiency can be measured at 57%. Efficiency will decrease substantially as load current drops below 1mA or when the voltage level at V_{IN} approaches the voltage level at V_{OUT} .

Additional Applications

The current sources of the AAT3103 can be combined to drive higher current levels through a single LED. As an example, a single LED can be driven at 60mA total by combining together the D1-D3 outputs as shown in Figure 6.

For lower-cost applications, the flying capacitor can be removed. This will force the AAT3103 to operate in 1x mode. To maintain regulated LED current, the input supply voltage must be greater than the charge pump's dropout voltage and the current source voltage drop in 1x mode. For example, to power 3.0V V_F with 20mA LED current, V_{IN} should be greater than 4.0V as shown in Figure 7.

Capacitor Selection

Careful selection of the three external capacitors C_{IN} , C_P , and C_{OUT} is important because they will affect turn-on time, output ripple, and transient performance. Optimum

performance will be obtained when low equivalent series resistance (ESR) ceramic capacitors are used; in general, low ESR may be defined as less than 100mΩ. A value of 1μF for all three capacitors is a good starting point when choosing capacitors.

Capacitor Characteristics

Ceramic composition capacitors are highly recommended over all other types of capacitors for use with the AAT3103. Ceramic capacitors offer many advantages over their tantalum and aluminum electrolytic counterparts. A ceramic capacitor typically has very low ESR, is lowest cost, has a smaller PCB footprint, and is non-polarized. Low ESR ceramic capacitors help to maximize charge pump transient response. Since ceramic capacitors are non-polarized, they are not prone to incorrect connection damage.

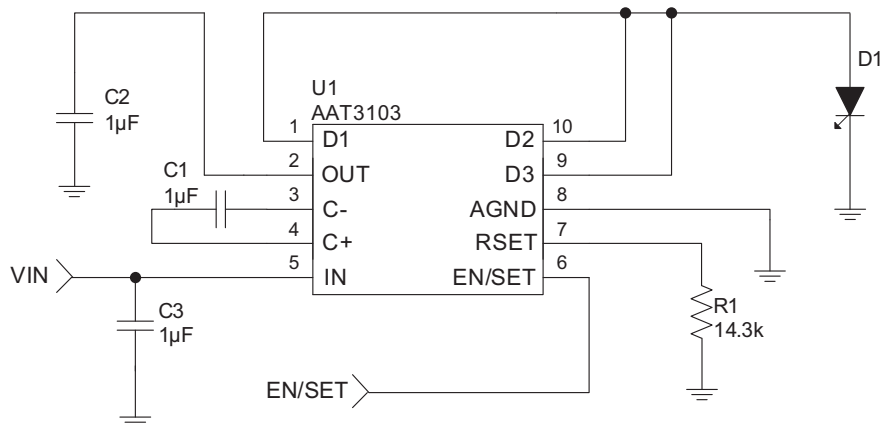

Figure 6: Higher Current, Single LED Application.

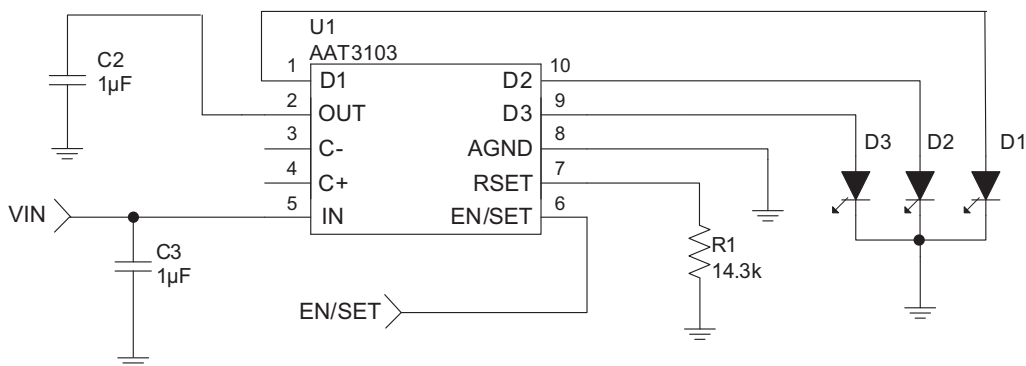

Figure 7: Lower Cost 1x Mode Application.

Evaluation Board Schematic

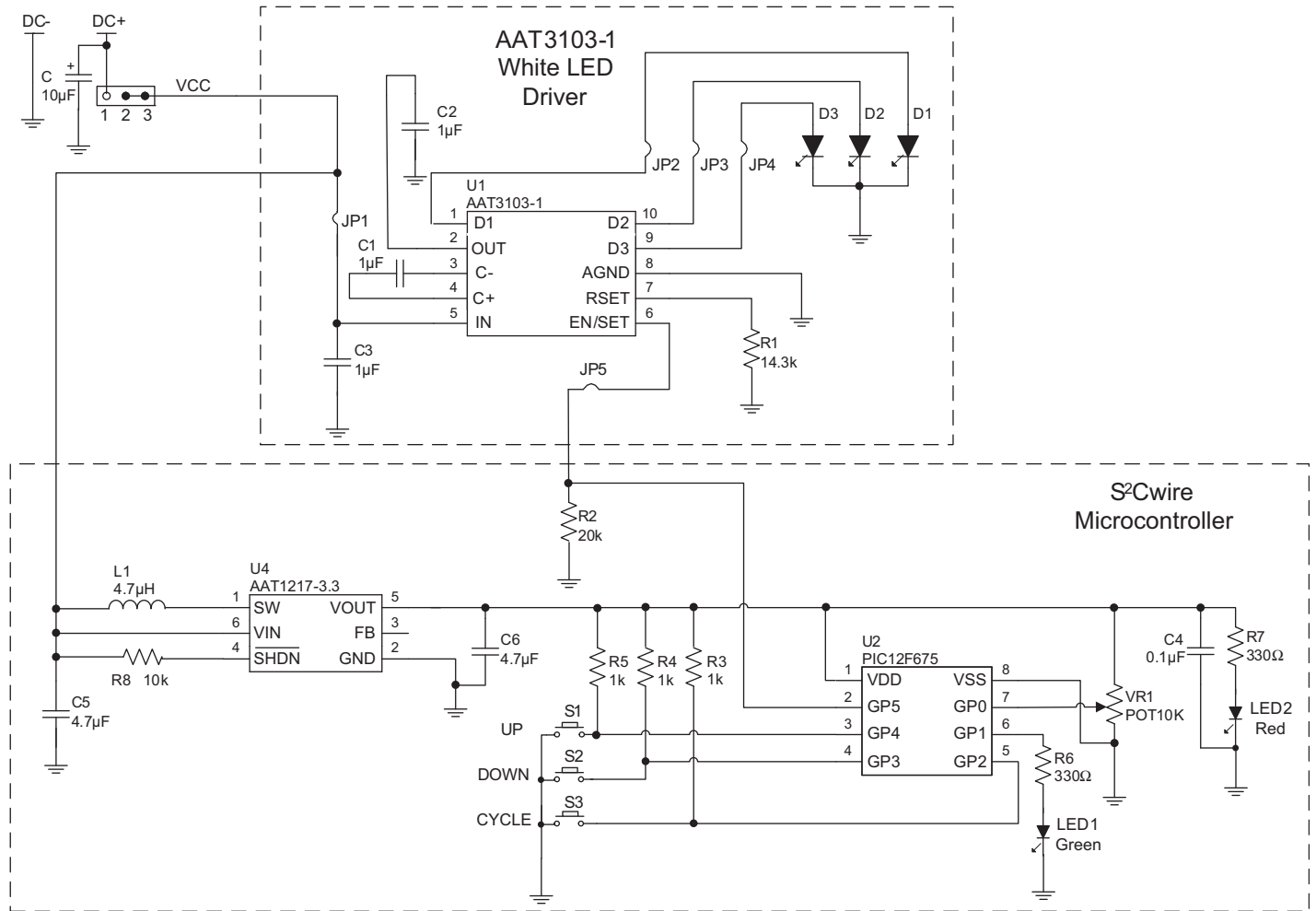

Figure 8: AAT3103 Evaluation Board Schematic.

Evaluation Board Layout

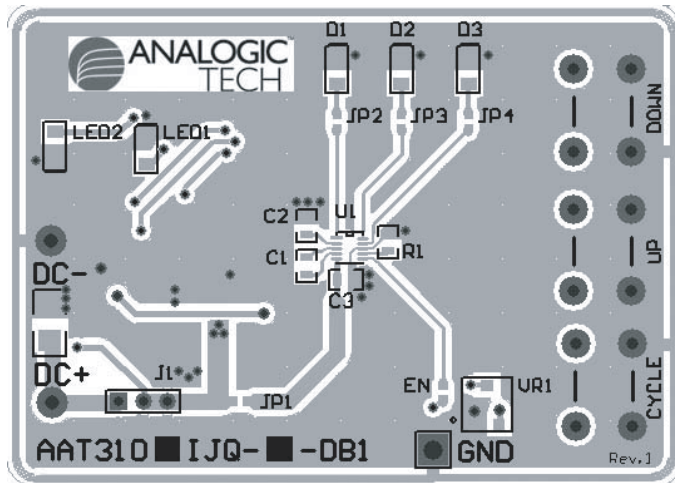

Figure 9: AAT3103 Evaluation Board Component Side PCB Layout.

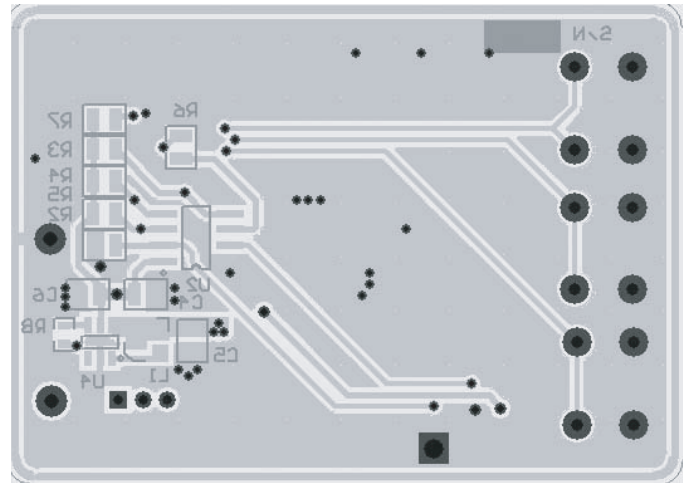

Figure 10: AAT3103 Evaluation Board Solder Side PCB Layout.

Ordering Information

Package	Interface	Current Control, Inverting	Marking ¹	Part Number (Tape and Reel) ²
SC70JW-10	S ² Cwire	16-step	1DXY	AAT3103IJQ-1-T1
SC70JW-10	S ² Cwire	8-step		AAT3103IJQ-2-T1
SC70JW-10	PWM	Linear	2TXY	AAT3103IJQ-4-T1



All AnalogicTech products are offered in Pb-free packaging. The term “Pb-free” means semiconductor products that are in compliance with current RoHS standards, including the requirement that lead not exceed 0.1% by weight in homogeneous materials. For more information, please visit our website at <http://www.analogictech.com/about/quality.aspx>.

Package Information

SC70JW-10

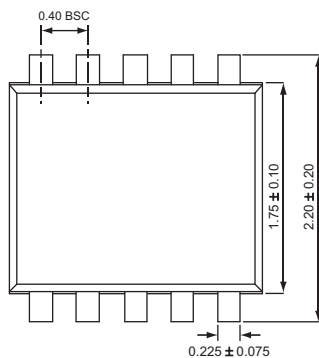

Top View

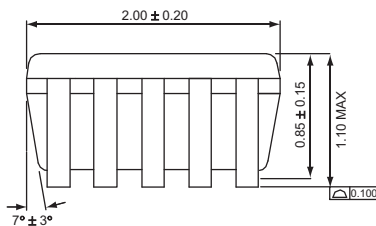

Side View

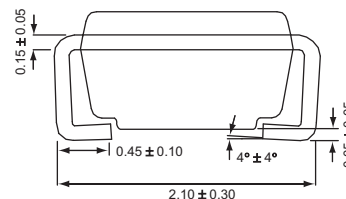

End View

All dimensions in millimeters.

1. XYY = assembly and date code.
2. Sample stock is generally held on part numbers listed in **BOLD**.



ChargePump™

3-Channel Charge-Pump LED Driver

Advanced Analogic Technologies, Inc.
3230 Scott Boulevard, Santa Clara, CA 95054
Phone (408) 737-4600
Fax (408) 737-4611



© Advanced Analogic Technologies, Inc.
AnalogicTech cannot assume responsibility for use of any circuitry other than circuitry entirely embodied in an AnalogicTech product. No circuit patent licenses, copyrights, mask work rights, or other intellectual property rights are implied. AnalogicTech reserves the right to make changes to their products or specifications or to discontinue any product or service without notice. Except as provided in AnalogicTech's terms and conditions of sale, AnalogicTech assumes no liability whatsoever, and AnalogicTech disclaims any express or implied warranty relating to the sale and/or use of AnalogicTech products including liability or warranties relating to fitness for a particular purpose, merchantability, or infringement of any patent, copyright or other intellectual property right. In order to minimize risks associated with the customer's applications, adequate design and operating safeguards must be provided by the customer to minimize inherent or procedural hazards. Testing and other quality control techniques are utilized to the extent AnalogicTech deems necessary to support this warranty. Specific testing of all parameters of each device is not necessarily performed. AnalogicTech and the AnalogicTech logo are trademarks of Advanced Analogic Technologies Incorporated. All other brand and product names appearing in this document are registered trademarks or trademarks of their respective holders.