

TC7MB3257FK

Quad 1-of-2 Multiplexer/Demultiplexer

The TC7MB3257FK is high-speed CMOS quad 1-2 multiplexer/demultiplexer. The low on resistance of the switch allows connections to be made with minimal propagation delay time.

This device consists of four individual two-inputs multiplexer/demultiplexer with common select input (S) and output enable (\overline{OE}). The A inputs is connected to the B1 or B2 outputs determined by the combination both the select input (S) and output enable (\overline{OE}). When the output enable (\overline{OE}) input is held "H" level, the switches are open with regardless the state of select inputs and a high-impedance state exists between the switches.

All inputs are equipped with protection circuits against static discharge.

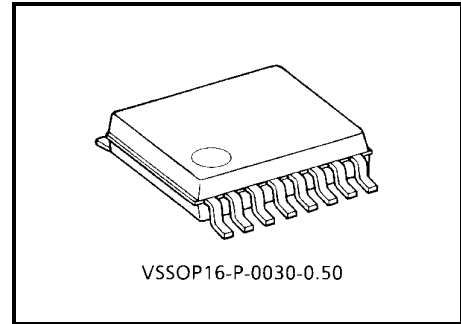

Weight: 0.02 g (typ.)

Features

- Operating voltage: $V_{CC} = 4.5\sim 5.5\text{ V}$
- High speed: $t_{pd} = 0.25\text{ ns (max)}$
- Low on resistance: $R_{ON} = 5\ \Omega\text{ (typ.)}$
- ESD performance: Machine model $\geq \pm 200\text{ V}$
Human body model $\geq \pm 2000\text{ V}$
- Compatible with TTL outputs (control inputs)
- Package: VSSOP (US16)
- Pin compatible with the 74xx257 type.
Functionally equivalent to (FST/CBT) 3257.

Pin Assignment (top view)

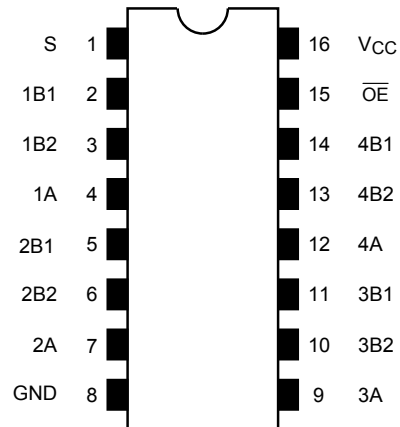

Truth Table

Inputs		Function
\overline{OE}	S	
L	L	A port = B1 port
L	H	A port = B2 port
H	X	Disconnect

System Diagram

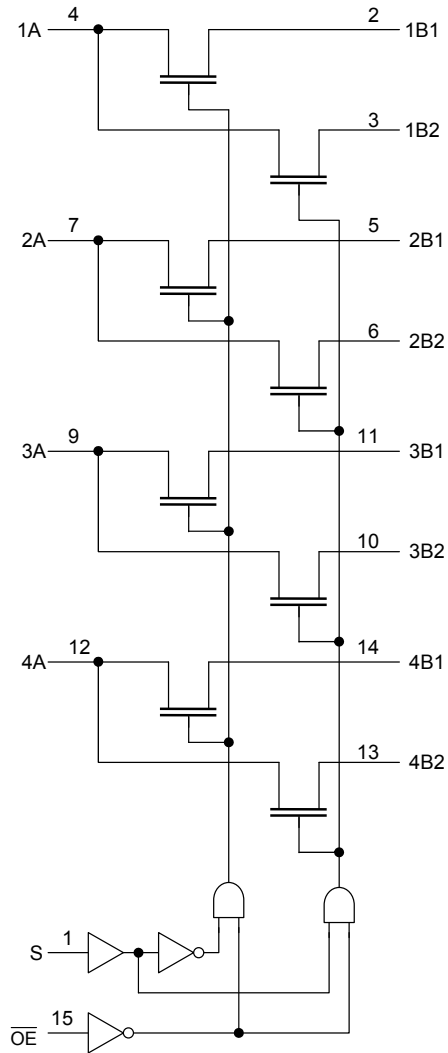

Absolute Maximum Ratings (Note)

Characteristics	Symbol	Rating	Unit
Power supply range	V_{CC}	-0.5~7.0	V
DC input voltage	V_{IN}	-0.5~7.0	V
DC switch voltage	V_S	-0.5~7.0	V
Input diode current	I_{IK}	-50	mA
Continuous channel current	I_S	128	mA
Power dissipation	P_D	180	mW
DC V_{CC}/GND current	I_{CC}/I_{GND}	± 100	mA
Storage temperature	T_{stg}	-65~150	$^{\circ}C$

Note: Exceeding any of the absolute maximum ratings, even briefly, lead to deterioration in IC performance or even destruction.

Using continuously under heavy loads (e.g. the application of high temperature/current/voltage and the significant change in temperature, etc.) may cause this product to decrease in the reliability significantly even if the operating conditions (i.e. operating temperature/current/voltage, etc.) are within the absolute maximum ratings and the operating ranges.

Please design the appropriate reliability upon reviewing the Toshiba Semiconductor Reliability Handbook ("Handling Precautions"/"Derating Concept and Methods") and individual reliability data (i.e. reliability test report and estimated failure rate, etc).

Operating Ranges (Note)

Characteristics	Symbol	Rating	Unit
Supply voltage	V_{CC}	4.5~5.5	V
Input voltage	V_{IN}	0~5.5	V
Switch voltage	V_S	0~5.5	V
Operating temperature	T_{opr}	-40~85	$^{\circ}C$
Input rise and fall time	dt/dv	0~10	ns/V

Note: The operating ranges must be maintained to ensure the normal operation of the device.
Unused inputs must be tied to either VCC or GND.

Electrical Characteristics

DC Characteristics (Ta = -40~85°C)

Characteristics	Symbol	Test Condition	V _{CC} (V)	Min	Typ. (Note 1)	Max	Unit	
Input voltage	"H" level	V _{IH}	—	4.5~5.5	2.0	—	—	V
	"L" level	V _{IL}	—	4.5~5.5	—	—	0.8	
Input leakage current (\overline{OE} , S)	I _{IN}	V _{IN} = 0~5.5 V		4.5~5.5	—	—	±1.0	μA
Power off leakage current	I _{OFF}	A, B, \overline{OE} = 0~5.5 V		0	—	—	±1.0	μA
Off-state leakage current (switch off)	I _{SZ}	A, B = 0~5.5 V, \overline{OE} = V _{CC}		4.5~5.5	—	—	±1.0	μA
ON resistance (Note 2)	R _{ON}	V _{IS} = 0 V	I _{IS} = 64 mA	4.5	—	5	7	Ω
			I _{IS} = 30 mA	4.5	—	5	7	
		V _{IS} = 2.4 V, I _{IS} = 15 mA		4.5	—	10	15	
Increase in I _{CC} per input	I _{CC}	V _{IN} = V _{CC} or GND, I _{OUT} = 0		5.5	—	—	10	μA
	ΔI _{CC}	V _{IN} = 3.4 V (one input)		5.5	—	—	2.5	mA

Note 1: Typical values are at V_{CC} = 5 V, Ta = 25°C.

Note 2: Measured by the voltage drop between A and B pins at the indicated current through the switch.
ON resistance is determined by the lower of the voltages on the two (A or B) pins.

AC Characteristics (Ta = -40~85°C)

Characteristics	Symbol	Test Condition	V _{CC} (V)	Min	Max	Unit
Propagation delay time (bus to bus)	t _{pLH} t _{pHL}	Figure 1, Figure 2 (Note)	4.5	—	0.25	ns
Propagation delay time (S to bus)	t _{pLH} t _{pHL}	Figure 1, Figure 2	4.5	—	5.0	ns
Output enable time (\overline{OE} to bus)	t _{pZL} t _{pZH}	Figure 1, Figure 3	4.5	—	5.5	ns
Output enable time (S to bus)	t _{pZL} t _{pZH}	Figure 1, Figure 3	4.5	—	5.5	ns
Output disable time (\overline{OE} to bus)	t _{pLZ} t _{pHZ}	Figure 1, Figure 3	4.5	—	5.0	ns
Output disable time (S to bus)	t _{pLZ} t _{pHZ}	Figure 1, Figure 3	4.5	—	5.0	ns

Note: This parameter is guaranteed by design but is not tested. The bus switch contributes no propagation delay other than the RC delay of the typical on resistance of the switch and the 50 pF load capacitance, when driven by an ideal voltage the source (zero output impedance).

Capacitive Characteristics (Ta = 25°C)

Characteristics	Symbol	Test Condition	V _{CC} (V)	Typ.	Unit	
Control pin input capacitance (\overline{OE} , S)	C _{IN}	(Note)	5.0	3	pF	
Switch terminal capacitance (B1~2)	C _{I/O}	\overline{OE} = V _{CC}	(Note)	5.0	10	pF
Switch terminal capacitance (A)	C _{I/O}	\overline{OE} = V _{CC}	(Note)	5.0	17	pF

Note: This parameter is guaranteed by design.

AC Test Circuit

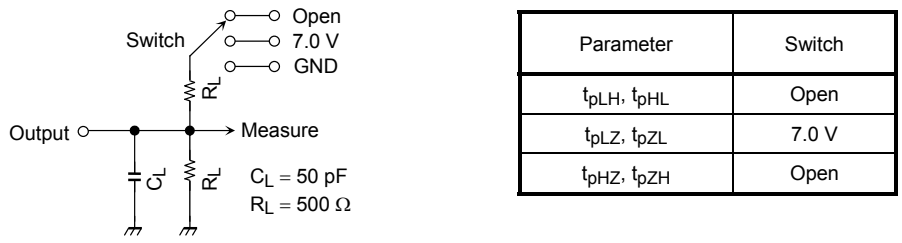

Figure 1

AC Waveform

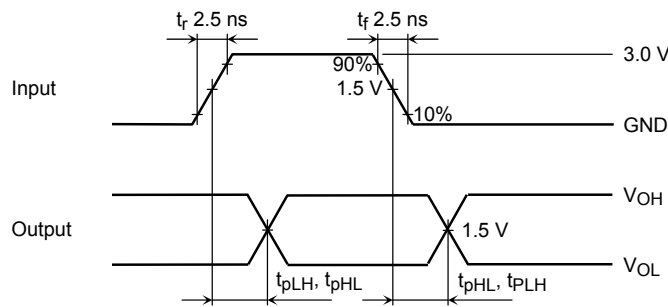

Figure 2 t_{pLH}, t_{pHL}

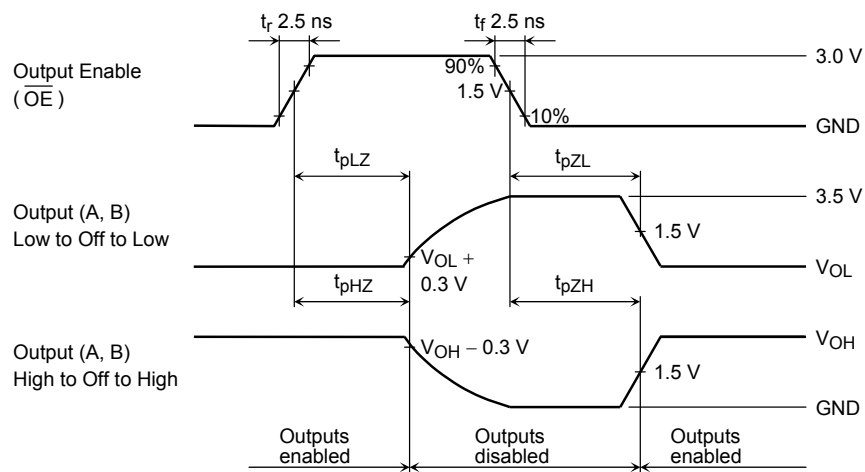
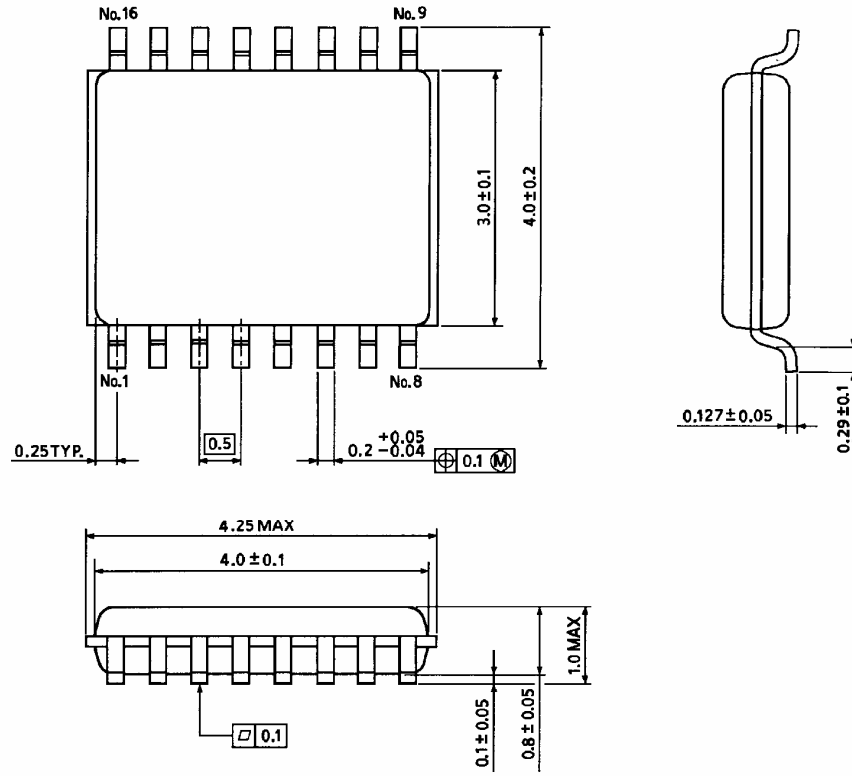

Figure 3 $t_{pLZ}, t_{pHZ}, t_{pZL}, t_{pZH}$

Package Dimensions

VSSOP16-P-0030-0.50

Unit : mm



Weight: 0.02 g (typ.)

RESTRICTIONS ON PRODUCT USE

20070701-EN GENERAL

- The information contained herein is subject to change without notice.
- TOSHIBA is continually working to improve the quality and reliability of its products. Nevertheless, semiconductor devices in general can malfunction or fail due to their inherent electrical sensitivity and vulnerability to physical stress. It is the responsibility of the buyer, when utilizing TOSHIBA products, to comply with the standards of safety in making a safe design for the entire system, and to avoid situations in which a malfunction or failure of such TOSHIBA products could cause loss of human life, bodily injury or damage to property.
In developing your designs, please ensure that TOSHIBA products are used within specified operating ranges as set forth in the most recent TOSHIBA products specifications. Also, please keep in mind the precautions and conditions set forth in the "Handling Guide for Semiconductor Devices," or "TOSHIBA Semiconductor Reliability Handbook" etc.
- The TOSHIBA products listed in this document are intended for usage in general electronics applications (computer, personal equipment, office equipment, measuring equipment, industrial robotics, domestic appliances, etc.). These TOSHIBA products are neither intended nor warranted for usage in equipment that requires extraordinarily high quality and/or reliability or a malfunction or failure of which may cause loss of human life or bodily injury ("Unintended Usage"). Unintended Usage include atomic energy control instruments, airplane or spaceship instruments, transportation instruments, traffic signal instruments, combustion control instruments, medical instruments, all types of safety devices, etc.. Unintended Usage of TOSHIBA products listed in this document shall be made at the customer's own risk.
- The products described in this document shall not be used or embedded to any downstream products of which manufacture, use and/or sale are prohibited under any applicable laws and regulations.
- The information contained herein is presented only as a guide for the applications of our products. No responsibility is assumed by TOSHIBA for any infringements of patents or other rights of the third parties which may result from its use. No license is granted by implication or otherwise under any patents or other rights of TOSHIBA or the third parties.
- Please contact your sales representative for product-by-product details in this document regarding RoHS compatibility. Please use these products in this document in compliance with all applicable laws and regulations that regulate the inclusion or use of controlled substances. Toshiba assumes no liability for damage or losses occurring as a result of noncompliance with applicable laws and regulations.