



DATA SHEET

SB820FCT~SB8150FCT

ISOLATION SCHOTTKY BARRIER RECTIFIERS

VOLTAGE 20 to 150 Volts **CURRENT** 8 Amperes

ITO-220AB

Unit : inch (mm)

FEATURES

- Plastic package has Underwriters Laboratory Flammability Classification 94V-O utilizing Flame Retardant Epoxy Molding Compound.
- Exceeds environmental standards of MIL-S-19500/228
- Low power loss, high efficiency.
- Low forward voltage, high current capability
- High surge capacity.
- For use in low voltage, high frequency inverters free wheeling, and polarity protection applications.
- Both normal and Pb free product are available :
Normal : 80~95% Sn, 5~20% Pb
Pb free: 99% Sn above

MECHANICAL DATA

Case: ITO-220AB full molded plastic package
Terminals: Lead solderable per MIL-STD-202G, Method 208
Polarity: As marked.
Mounting Position: Any
Weight: 0.08 ounces, 2.24grams.

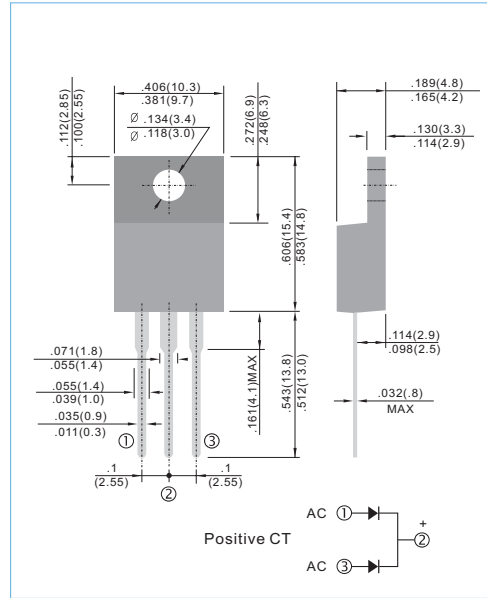

MAXIMUM RATINGS AND ELECTRICAL CHARACTERISTICS

Ratings at 25°C ambient temperature unless otherwise specified. Single phase, half wave, 60 Hz, resistive or inductive load.
For capacitive load, derate current by 20%

PARAMETER	SYMBOL	SB820 FCT	SB830 FCT	SB840 FCT	SB850 FCT	SB860 FCT	SB880 FCT	SB8100 FCT	SB8150 FCT	UNITS
Maximum Recurrent Peak Reverse Voltage	V _{RRM}	20	30	40	50	60	80	100	150	V
Maximum RMS Voltage	V _{RMS}	14	21	28	35	42	56	70	105	V
Maximum DC Blocking Voltage	V _{DC}	20	30	40	50	60	80	100	150	V
Maximum Average Forward Current .375"(9.5mm) lead length at T _c =100°C	I _{AV}	8								A
Peak Forward Surge Current :8.3ms single half sine-wave superimposed on rated load(JEDEC method)	I _{FSM}	150								A
Maximum Forward Voltage at 4.0A	V _F	0.55		0.75		0.85		0.92		V
Maximum DC Reverse Current T _A =25°C at Rated DC Blocking Voltage T _A =100°C	I _R	0.5 50								mA
Typical Thermal Resistance	R _{θJC}	6								°C / W
Operating Junction Temperature Rang	T _J	-50 to +125								°C
Storage Temperature Rang	T _J , T _{STG}	-50 to +150								°C

Note.

Both Bonding and Chip structure are available.



RATING AND CHARACTERISTIC CURVES

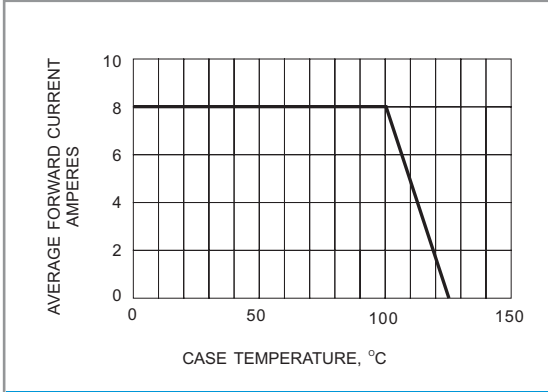

Fig.1- FORWARD CURRENT DERATING CURVE

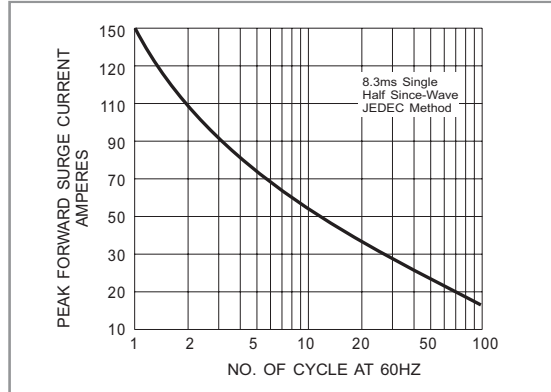

Fig.2- MAXIMUM NON - REPETITIVE SURGE CURRENT

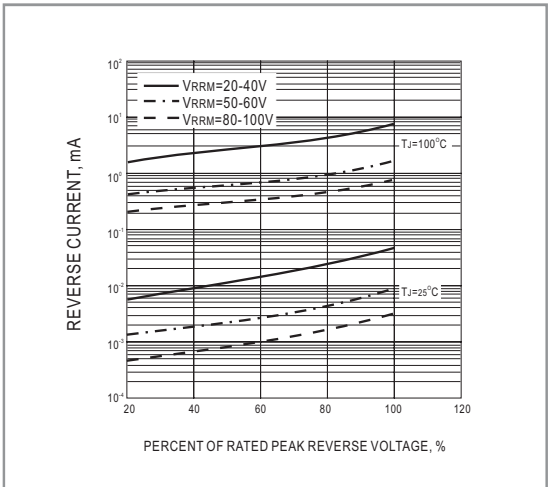

Fig.3- TYPICAL REVERSE CHARACTERISTIC

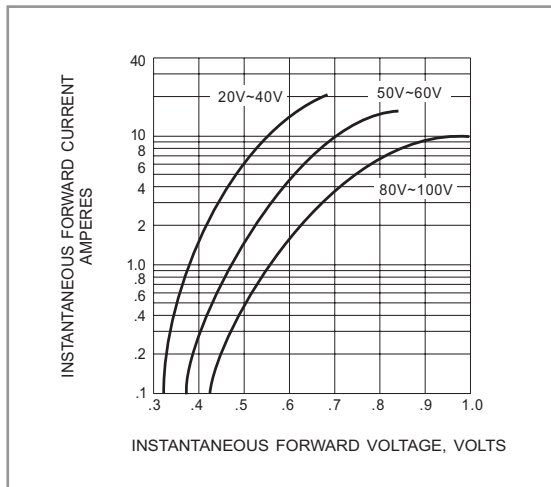

Fig.4- TYPICAL INSTANTANEOUS FORWARD CHARACTERISTICS