



FLC21 FAMILY

Application Specific Discretes
A.S.D.TM

LOW POWER
FIRE LIGHTER CIRCUIT

FEATURES

- DEDICATED THYRISTOR STRUCTURE FOR CAPACITIVE DISCHARGE IGNITION OPERATION
- HIGH PULSE CURRENT CAPABILITY
 $I_{FRM} = 90A @ t_p = 10\mu S$
- AC OR DC OPERATION CAPABILITY WITH SUPPLY FROM THE AC MAINS OR A DC BATTERY.

BENEFITS

- SPACE SAVING THANKS TO MONOLITHIC FUNCTION INTEGRATION
- HIGH RELIABILITY WITH PLANAR TECHNOLOGY

DESCRIPTION

The FLC21 series have been developed especially for capacitance discharge operation. The main applications are: fuel ignitor, fuel or gas heater, gas range, cook top, barbecue, water heater, HVAC, portable ignitor, insect killers.

It uses a high performance planar diffused technology device adapted to high temperature in rugged environmental conditions.

The typical supply of the FLC21 fire lighter circuit is a DC battery or the AC mains.

Th: Thyristor for the switching operation.

Z: Zener diode to set the igniting threshold voltage.

D: Diode for the reverse conduction.

R: 2 k Ω resistor.

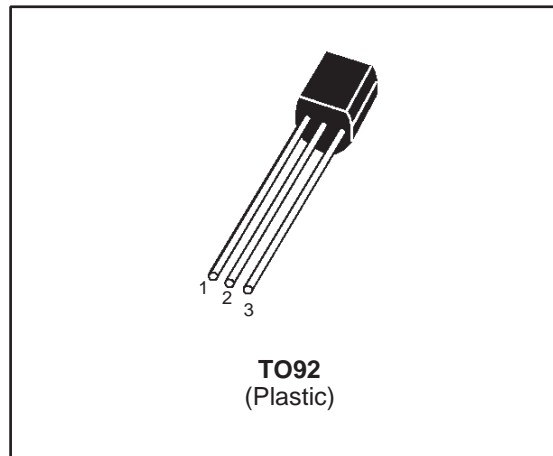

FUNCTIONAL DIAGRAM

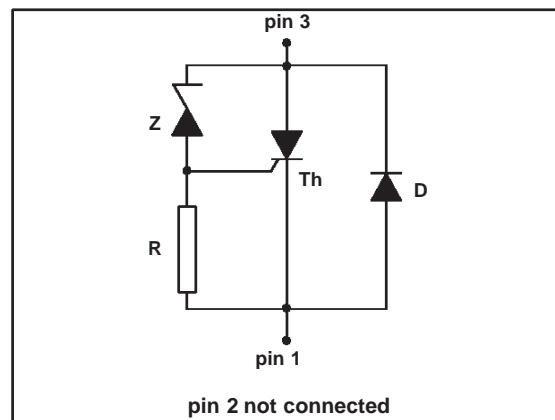

DEVICE TYPE	APPLICATION	MODE
FLC21-135A	BATTERY OPERATION	Ignition
FLC21-65A	100V Mains	Ignition

FLC21 FAMILY

ABSOLUTE RATINGS (limiting values)

Symbol	Parameter	Value	Unit
I_{TRM}	Repetitive surge peak on state current for thyristor $-30^{\circ}\text{C} \leq T_{amb} \leq 120^{\circ}\text{C}$	90 $t_p = 10\mu\text{s}$ (note 1)	A
I_{FRM}	Repetitive surge peak on state current for diode $-30^{\circ}\text{C} \leq T_{amb} \leq 120^{\circ}\text{C}$		
di/dt	Critical rate of rise on state current $-30^{\circ}\text{C} \leq T_{amb} \leq 120^{\circ}\text{C}$	50	A/ μs
T_{stg} T_j	Storage junction temperature range Maximum junction temperature	- 40 to + 150 125	$^{\circ}\text{C}$
T_{amb}	Operating temperature range	- 30 to + 120	$^{\circ}\text{C}$
T_L	Maximum lead temperature for soldering during 10s	260	$^{\circ}\text{C}$

Note 1 : Test current waveform

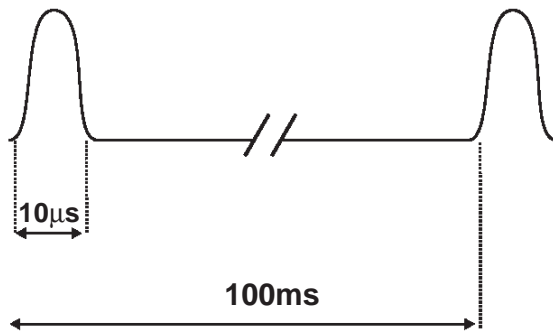

THERMAL RESISTANCE

Symbol	Parameter	Value	Unit
$R_{th(j-a)}$	Junction to ambient	150	$^{\circ}\text{C}/\text{W}$

ORDERING INFORMATION

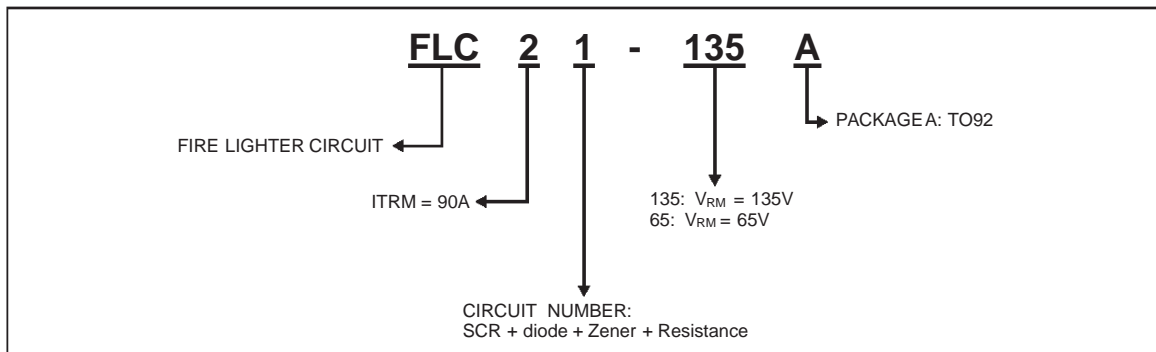

ELECTRICAL CHARACTERISTICS

Symbol	Parameters
V_{RM}	Stand-off voltage
V_{BO}	Breakover voltage
V_T	On-state voltage
V_F	Diode forward voltage drop
I_{BO}	Breakover current
I_{RM}	Leakage current
αT	Temperature coefficient for V_{BO}

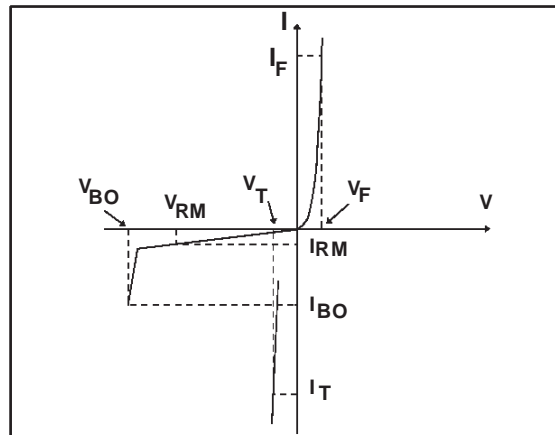

DIODE (D) PARAMETER

Symbol	Test Conditions				Value	Unit
V_F	$I_F = 1A$	$tp \leq 500\mu s$	$T_j = 25^\circ C$	Max.	1.7	V

THYRISTOR (Th) and ZENER (Z) PARAMETERS

Symbol	Test conditions		Value						Unit
			FLC21-65A			FLC21-135A			
			Min.	Typ.	Max.	Min.	Typ.	Max.	
I_{RM}	$V_{RM} = 65V$ for FLC21-65A	$T_j = 25^\circ C$			1			1	μA
	$V_{RM} = 135V$ for FLC21-135A	$T_j = 125^\circ C$			10			10	μA
V_{BO}	at I_{BO}	$T_j = 25^\circ C$	70		80	140		160	V
I_{BO}	at V_{BO}	$T_j = 25^\circ C$			500			500	μA
V_T	$I_T = 2A$	$tp \leq 500\mu s$			1.7			1.7	V
αT				0.07			0.16		$V/^\circ C$

Fig.1: Relative variation of breakover current versus junction temperature.

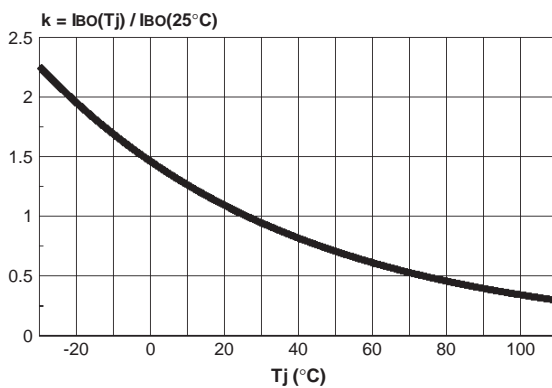

FLC21 FAMILY

Fig. 2: BASIC AC MAINS APPLICATION

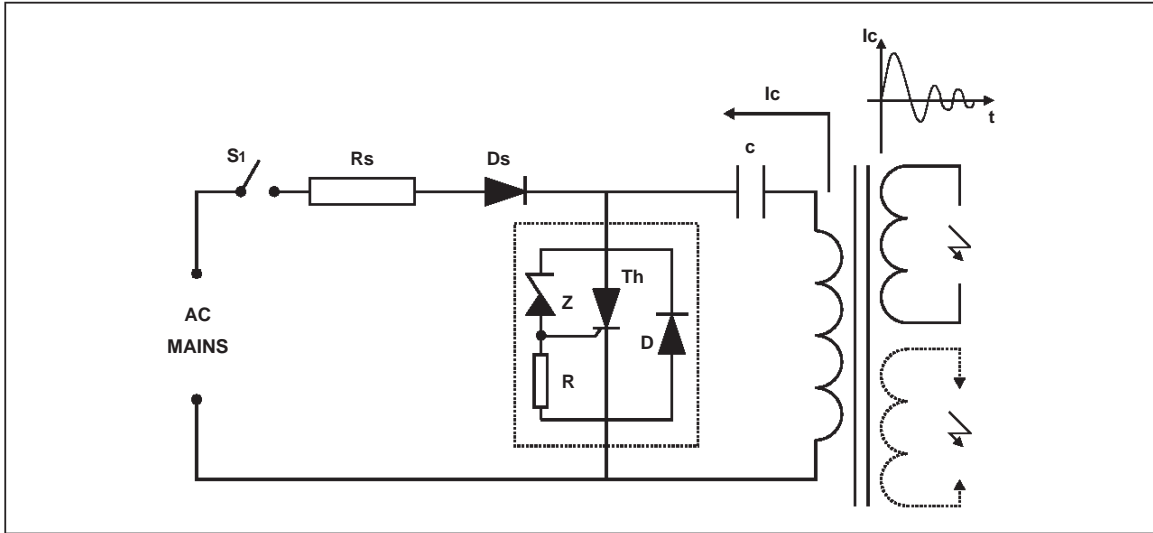
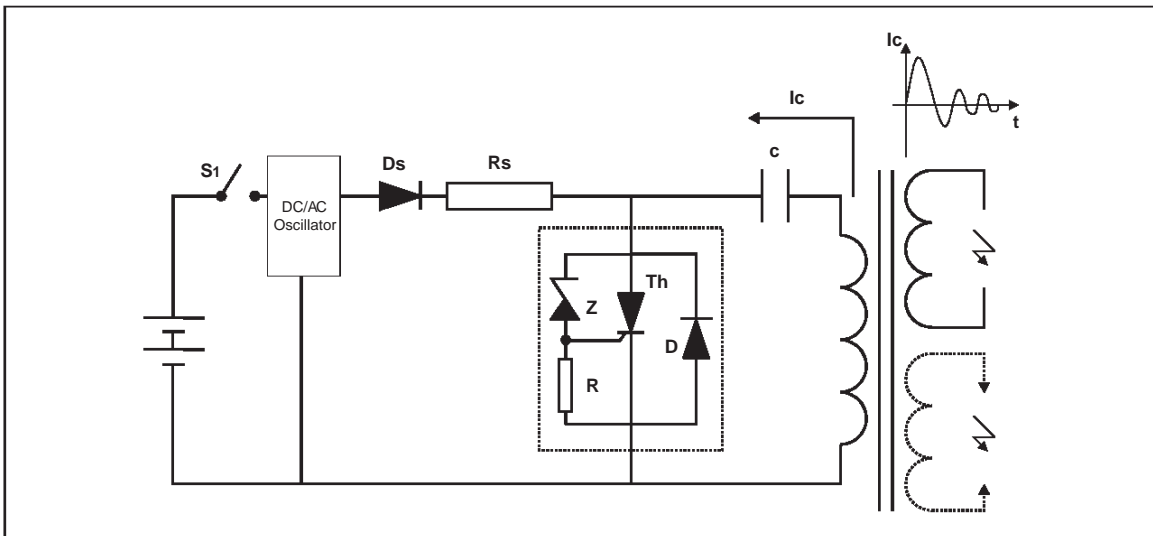

Fig. 3: BASIC DC APPLICATION



1/ IGNITION MODE

PHASE 1

The AC voltage is rectified by the diode Ds. The ignition energy is supplied by the mains and stored into the capacitor C.

PHASE 2

At the end of the phase 1, the voltage across the capacitor C reaches the avalanche threshold of the Zener diode Z. Then, a current flows through this Zener diode into the gate of the thyristor Th which is triggered.

The thyristor turn on generates an alternating current through the capacitor C. Its positive parts flow through the capacitor C, the primary of the HV transformer and the thyristor Th. Its negative parts of the current flow through C, D and the primary of the H.V transformer.

RS RESISTANCE CALCULATION

The Rs resistance allows, in addition with the capacitance C, to adjust the spark frequency and to limit the current supplied by the mains. This resistance allows the thyristor triggering in any

requested cases. In worst cases, the system must fire when the a.c. line voltage is minimum while the breakdown voltage V_{BO} and the current I_{BO} of the FLC are maximum.

The maximum Rs value is equal to:

$$R_{smax} = \frac{(V_{AC} \min. \sqrt{2}) - [V_{BO} \max. (1 + \alpha T. (T_{amb} - 25))]}{k \cdot I_{BO}^*}$$

* : see fig 1

Fig. 4: Spark frequency versus Rs and C

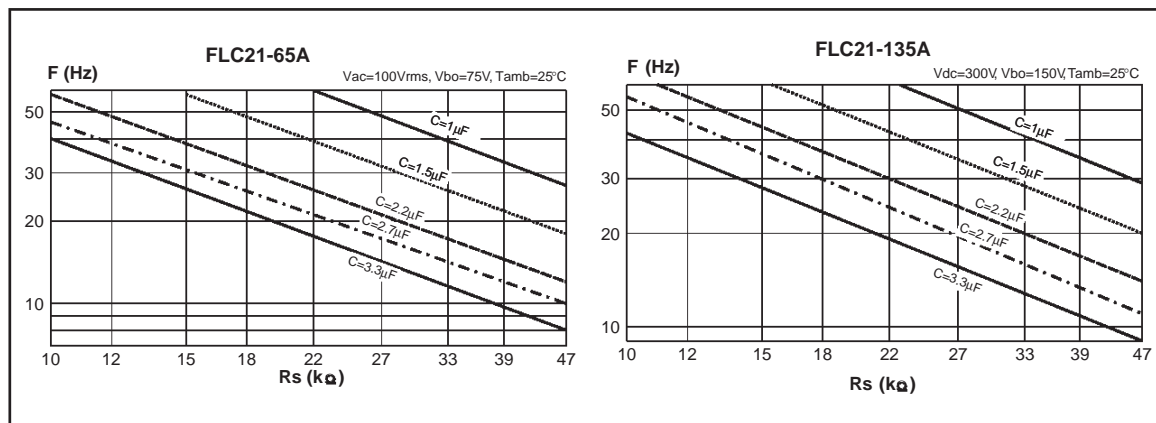

The couple Rs/C can be chosen with the previous curve. Keep in mind the Rs maximum limit for which the system would not work when the AC mains is minimum.

FLC21 FAMILY

PACKAGE MECHANICAL DATA TO92 (Plastic)

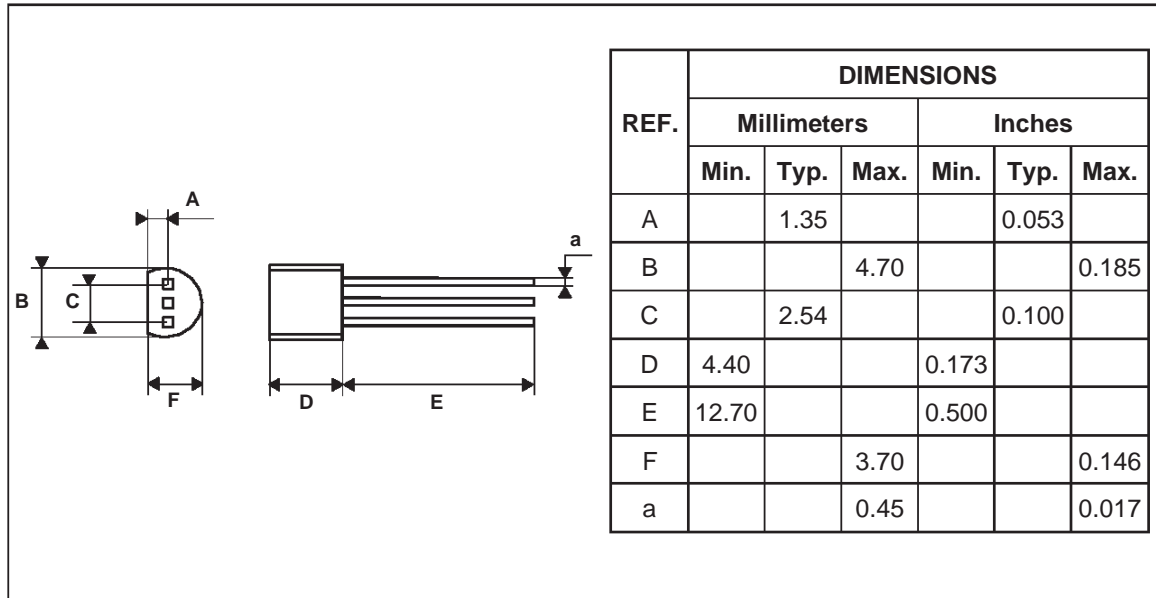

• Epoxy meets UL94, VO at 1/8"

Type	Marking	Package	Weight	Base qty	Delivery mode
FLC21-65A	FLC21-65A	TO-92	0.200g	2500	Bulk
FLC21-135A	FLC21-135A	TO-92	0.200g	2500	Bulk

Information furnished is believed to be accurate and reliable. However, STMicroelectronics assumes no responsibility for the consequences of use of such information nor for any infringement of patents or other rights of third parties which may result from its use. No license is granted by implication or otherwise under any patent or patent rights of STMicroelectronics. Specifications mentioned in this publication are subject to change without notice. This publication supersedes and replaces all information previously supplied. STMicroelectronics products are not authorized for use as critical components in life support devices or systems without express written approval of STMicroelectronics.

The ST logo is a registered trademark of STMicroelectronics

© 2000 STMicroelectronics - Printed in Italy - All rights reserved.

STMicroelectronics GROUP OF COMPANIES

Australia - Brazil - China - Finland - France - Germany - Hong Kong - India - Italy - Japan - Malaysia
Malta - Morocco - Singapore - Spain - Sweden - Switzerland - United Kingdom - U.S.A.

<http://www.st.com>