

HIGH FREQUENCY AMPLIFIER
NPN SILICON EPITAXIAL TRANSISTOR
MINI MOLD

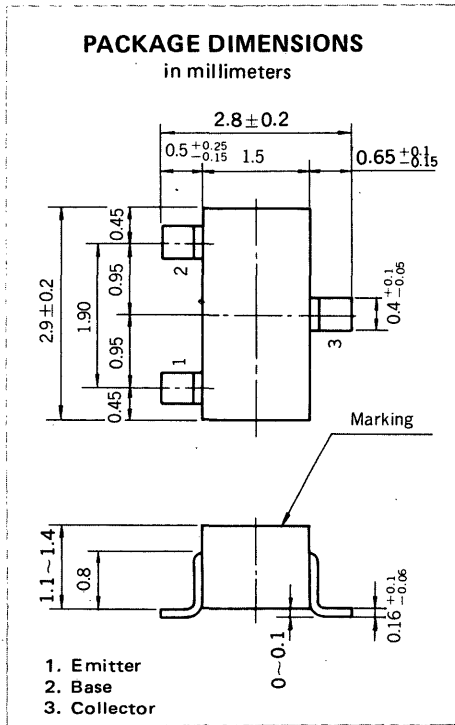

DESCRIPTION

The 2SC2223 is designed for use in small type equipments especially recommended for Hybrid Integrated Circuit and other applications.

FEATURES

- Micro package.
- High gain bandwidth product. $f_T = 600 \text{ MHz TYP.}$
- Low output capacitance. $C_{ob} = 1.0 \text{ pF TYP.}$

ABSOLUTE MAXIMUM RATINGS ($T_a = 25^\circ\text{C}$)

Maximum Voltages and Current

Collector to Base Voltage	V_{CB0}	30	V
Collector to Emitter Voltage	V_{CEO}	20	V
Emitter to Base Voltage	V_{EBO}	4.0	V
Collector Current	I_C	20	mA

Maximum Power Dissipation

Total Power Dissipation	P_T	150	mW
-------------------------	-------	-----	----

Maximum Temperatures

Storage Temperature	T_{stg}	-55 to +125	$^\circ\text{C}$
Junction Temperature	T_j	125	$^\circ\text{C}$

ELECTRICAL CHARACTERISTICS ($T_a = 25^\circ\text{C}$)

CHARACTERISTIC	SYMBOL	MIN.	TYP.	MAX.	UNIT	TEST CONDITIONS
Collector Cutoff Current	I_{CBO}			100	nA	$V_{CB} = 25 \text{ V, } I_E = 0$
Emitter Cutoff Current	I_{EBO}			100	nA	$V_{EB} = 3.0 \text{ V, } I_C = 0$
DC Current Gain	h_{FE}	40	90	180		$V_{CE} = 6.0 \text{ V, } I_C = 1.0 \text{ mA}$
Base to Emitter Voltage	V_{BE}		0.72		V	$V_{CE} = 6.0 \text{ V, } I_C = 1.0 \text{ mA}$
Collector Saturation Voltage	$V_{CE(sat)}$		0.1	0.3	V	$I_C = 10 \text{ mA, } I_B = 1.0 \text{ mA}$
Gain Bandwidth Product	f_T	400	600		MHz	$V_{CE} = 6.0 \text{ V, } I_E = -1.0 \text{ mA}$
Output Capacitance	C_{ob}		1.0		pF	$V_{CB} = 6.0 \text{ V, } I_E = 0, f = 1.0 \text{ MHz}$
Collector to Base Time Constant	$C_c \cdot r_{b'b}$		12		ps	$V_{CE} = 6.0 \text{ V, } I_E = -1.0 \text{ mA, } f = 31.9 \text{ MHz}$
Noise Figure	NF		3.0		dB	$V_{CE} = 6.0 \text{ V, } I_E = -1.0 \text{ mA, } R_G = 50 \Omega, f = 100 \text{ MHz}$ See Test Circuit

Classification of h_{FE}

Marking	F12	F13	F14
h_{FE} Range	40 to 80	60 to 120	90 to 180

TYPICAL CHARACTERISTICS ($T_a = 25^\circ\text{C}$ unless otherwise noted)

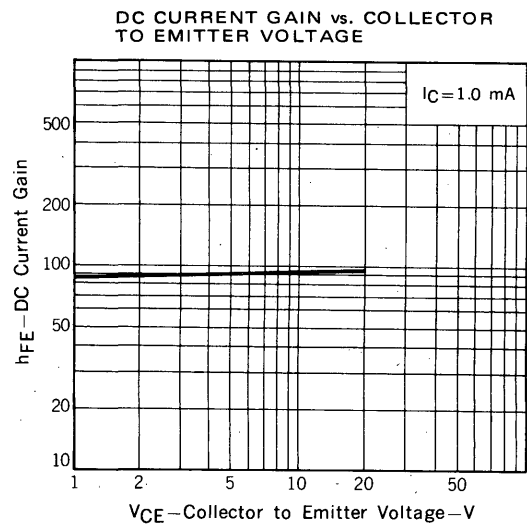
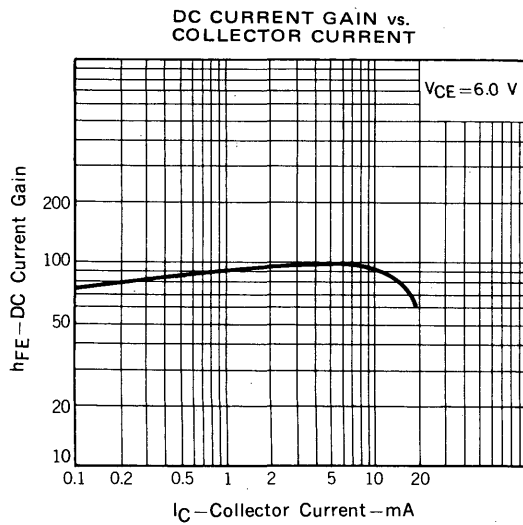
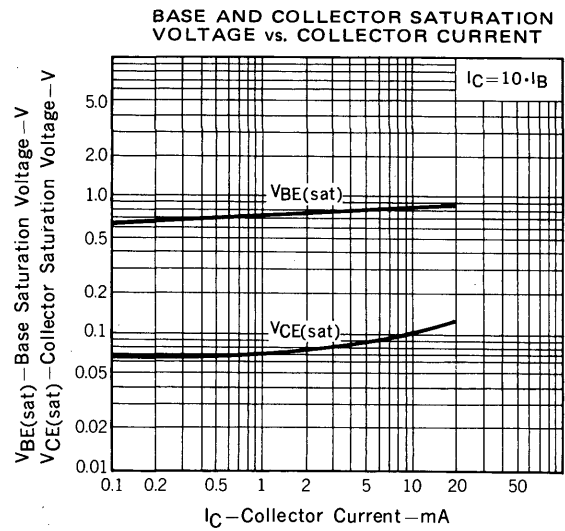
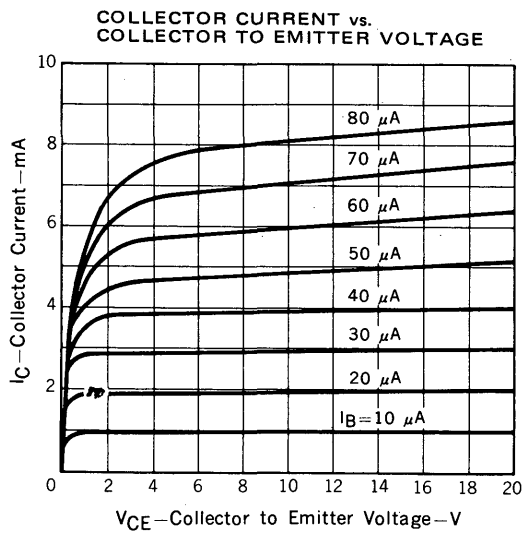
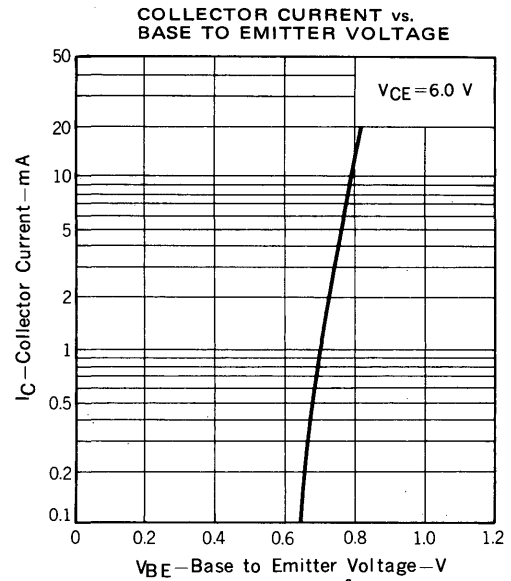
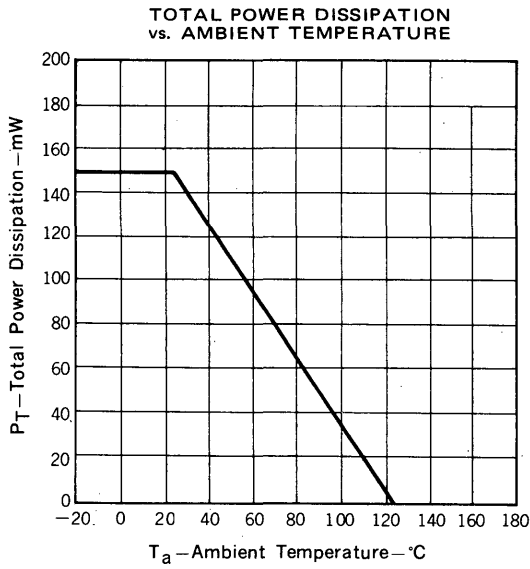

GAIN BANDWIDTH PRODUCT vs. EMITTER CURRENT

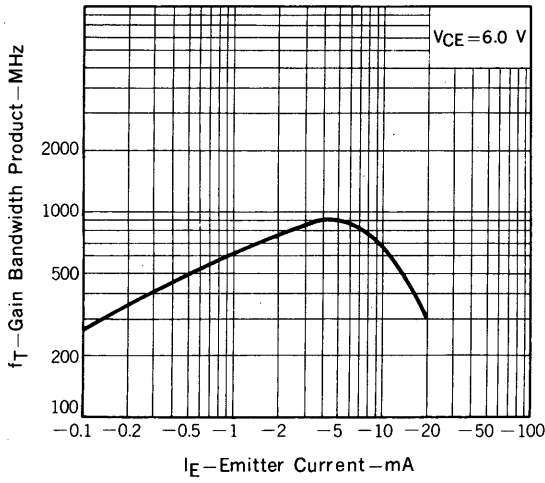

INPUT CAPACITANCE vs. EMITTER TO BASE VOLTAGE, OUTPUT CAPACITANCE vs. COLLECTOR TO BASE VOLTAGE

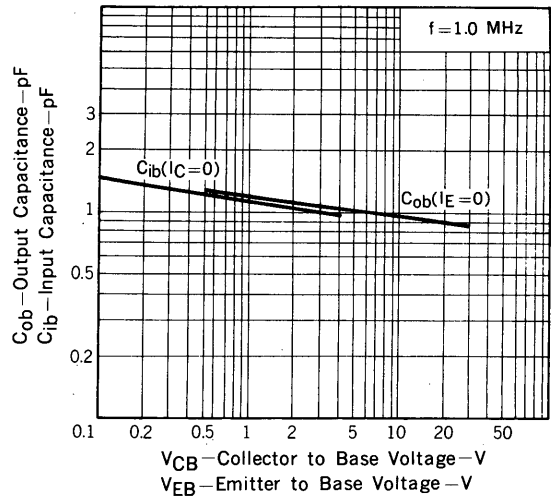

COLLECTOR TO BASE TIME CONSTANT vs. EMITTER CURRENT

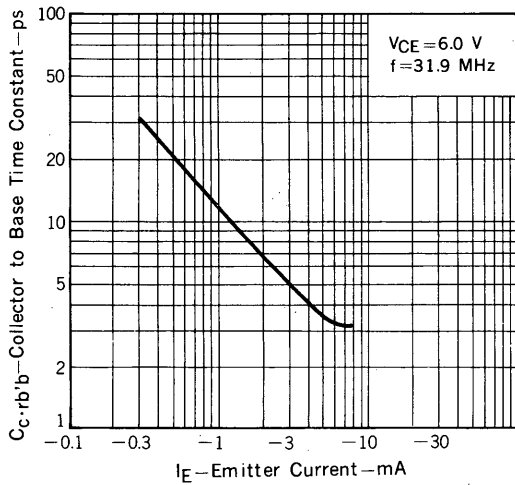

POWER GAIN, NOISE FIGURE vs. EMITTER CURRENT

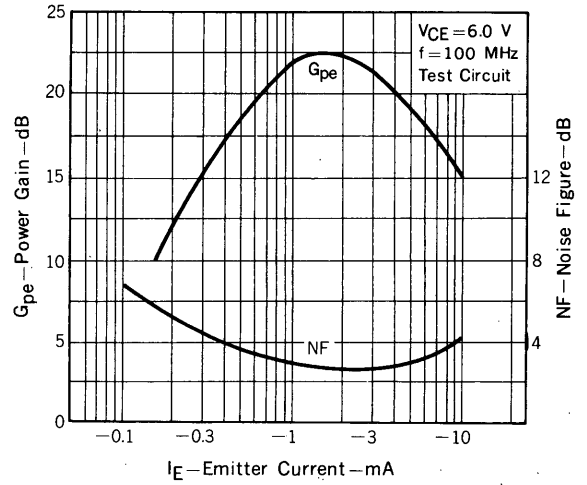

100 MHz G_{pe} , NF TEST CIRCUIT

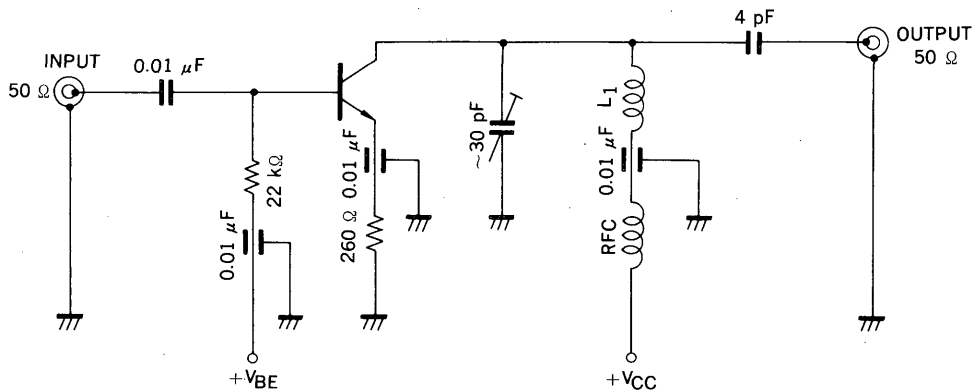

[MEMO]

No part of this document may be copied or reproduced in any form or by any means without the prior written consent of NEC Corporation. NEC Corporation assumes no responsibility for any errors which may appear in this document.

NEC Corporation does not assume any liability for infringement of patents, copyrights or other intellectual property rights of third parties by or arising from use of a device described herein or any other liability arising from use of such device. No license, either express, implied or otherwise, is granted under any patents, copyrights or other intellectual property rights of NEC Corporation or of others.