

Super FAP-G Series

N-CHANNEL SILICON POWER MOSFET

■ Features

- High speed switching
- No secondary breakdown
- Avalanche-proof
- Low on-resistance
- Low driving power

■ Applications

- Switching regulators
- UPS (Uninterruptible Power Supply)
- DC-DC converters

■ Maximum ratings and characteristic Absolute maximum ratings (Tc=25°C unless otherwise specified)

Item	Symbol	Ratings	Unit	Remarks
Drain-source voltage	V _{DS}	120	V	
	V _{DSSX}	90	V	V _{GS} =-30V
Continuous drain current	I _D	67	A	
Pulsed drain current	I _{D(puls)}	±268	A	
Gate-source voltage	V _{GS}	±30	V	
Repetitive or non-repetitive	I _{AR}	67	A	Note *1
Non-repetitive Maximum avalanche energy	E _{AS}	719.1	mJ	Note *2
Repetitive Maximum avalanche energy		27.0	mJ	Note *3
Maximum drain-source dV/dt	dV _{DS} /dt	20	kV/μs	V _{DS} ≤ 120V
Peak diode recovery dV/dt	dV/dt	5	kV/μs	Note *4
Maximum power dissipation	P _d	2.02	W	T _a =25°C
		270	W	T _c =25°C
Operating and storage temperature range	T _{ch}	+150	°C	
	T _{stg}	-55 to +150	°C	

Note *1 T_{ch} ≤ 150°C

Note *2 Starting T_{ch}=25°C, I_{AS}=27A, L=1.32mH, V_{CC}=48V, R_G=50Ω
E_{AS} limited by maximum channel temperature and avalanche current.
See to 'Avalanche Energy' graph.

Note *3 Repetitive rating : Pulse width limited by maximum channel temperature.
See to 'Transient Thermal impedance' graph.

Note *4 I_r ≤ -I_D, -di/dt=50A/μs, V_{CC} ≤ BV_{DSS}, T_{ch} ≤ 150°C

■ Outline Drawings [mm]

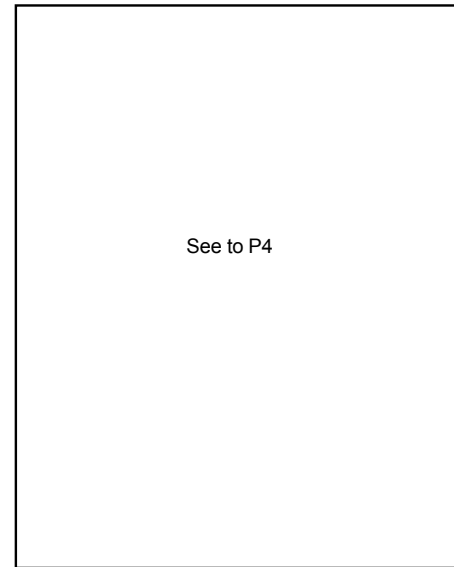

■ Equivalent circuit schematic

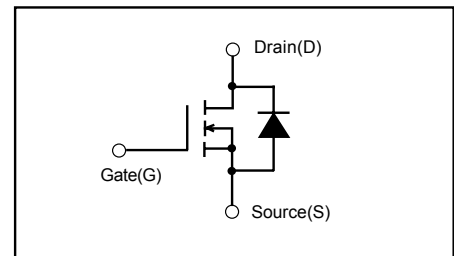

● Electrical characteristics (T_c =25°C unless otherwise specified)

Item	Symbol	Test Conditions	Min.	Typ.	Max.	Units
Drain-source breakdown voltage	V _{(BR)DSS}	I _D = 250μA V _{GS} =0V	120			V
Gate threshold voltage	V _{GS(th)}	I _D = 250μA V _{DS} =V _{GS}	3.0		5.0	V
Zero gate voltage drain current	I _{DSS}	V _{DS} =120V V _{GS} =0V T _{ch} =25°C			25	μA
		V _{DS} =96V V _{GS} =0V T _{ch} =125°C			250	
Gate-source leakage current	I _{GSS}	V _{GS} =±30V V _{DS} =0V			100	nA
Drain-source on-state resistance	R _{DS(on)}	I _D =33.5A V _{GS} =10V		24.6	30.0	mΩ
Forward transconductance	g _{fs}	I _D =33.5A V _{DS} =25V	14	28		S
Input capacitance	C _{iss}	V _{DS} =75V		1880	2820	pF
Output capacitance	C _{oss}	V _{GS} =0V		360	540	
Reverse transfer capacitance	C _{rss}	f=1MHz		30	45	
Turn-on time t _{on}	td(on)	V _{CC} =48V I _D =33.5A		20	30	ns
	t _r	V _{GS} =10V		35	53	
Turn-off time t _{off}	td(off)	R _{GS} =10 Ω		50	75	
	t _r			23	35	
Total Gate Charge	Q _G	V _{CC} =60V		52	78	nC
Gate-Source Charge	Q _{GS}	I _D =67A		16	24	
Gate-Drain Charge	Q _{GD}	V _{GS} =10V		18	27	
Diode forward on-voltage	V _{SD}	I _F =67A V _{GS} =0V T _{ch} =25°C		1.10	1.50	V
Reverse recovery time	t _{rr}	I _F =67A V _{GS} =0V		150		ns
Reverse recovery charge	Q _{rr}	-di/dt=100A/μs T _{ch} =25°C		0.9		μC

● Thermal characteristics

Item	Symbol	Test Conditions	Min.	Typ.	Max.	Units
Thermal resistance	R _{th(ch-c)}	channel to case			0.463	°C/W
	R _{th(ch-a)}	channel to ambient			62.0	°C/W

Characteristics

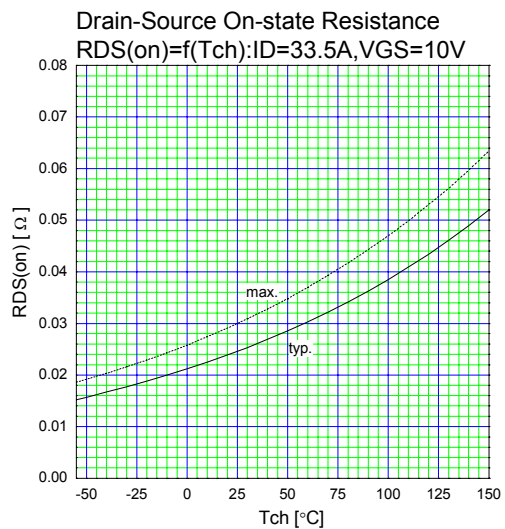
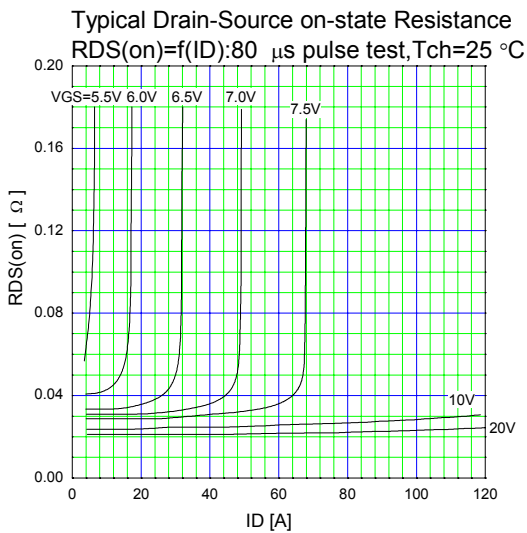
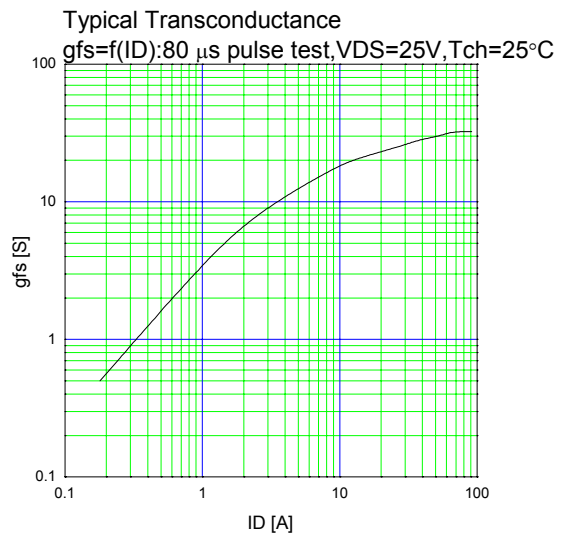
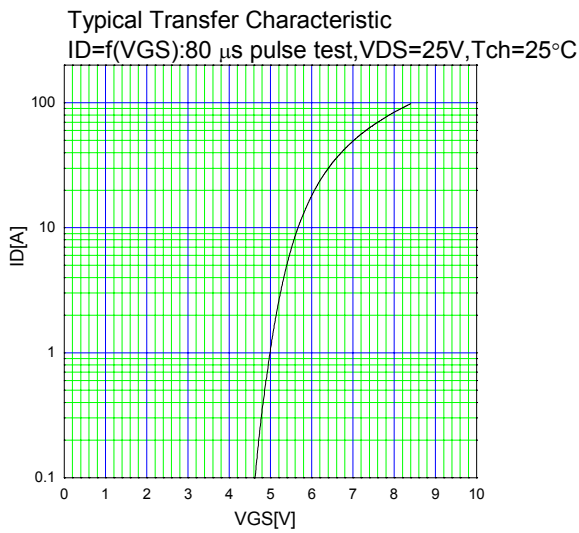
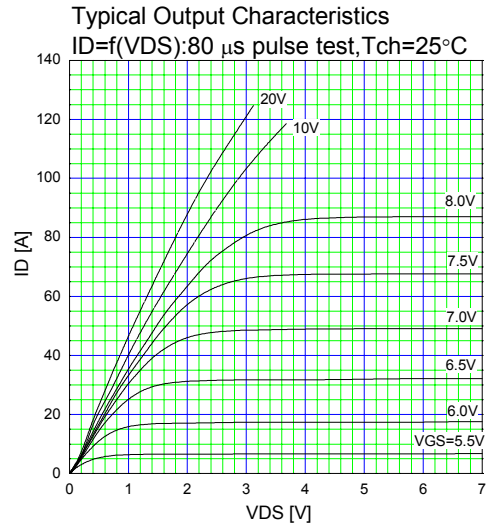
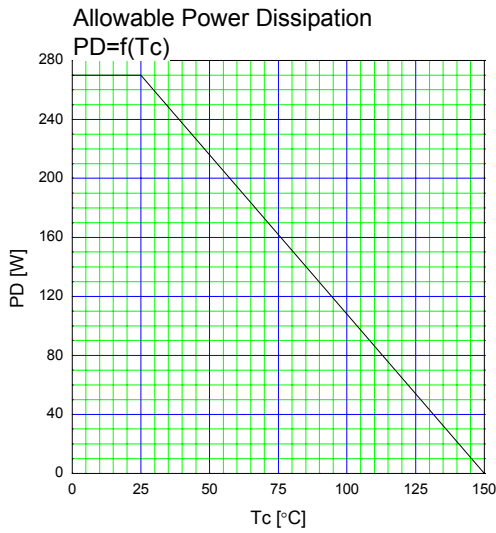

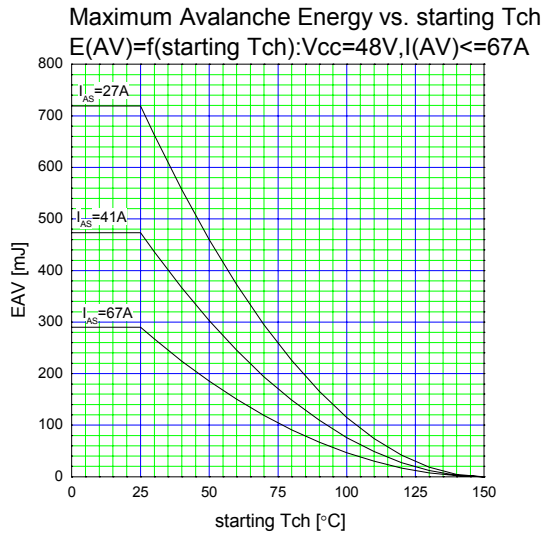
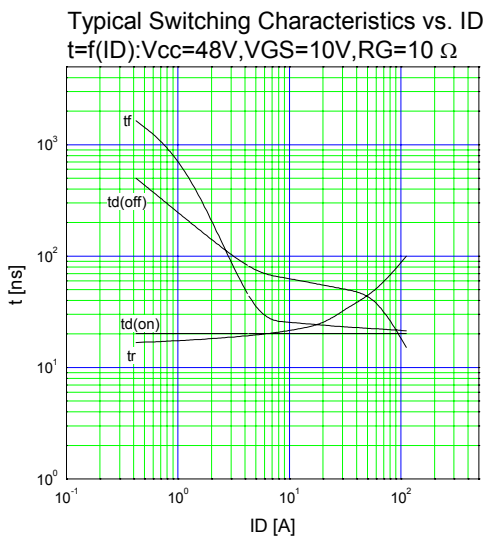
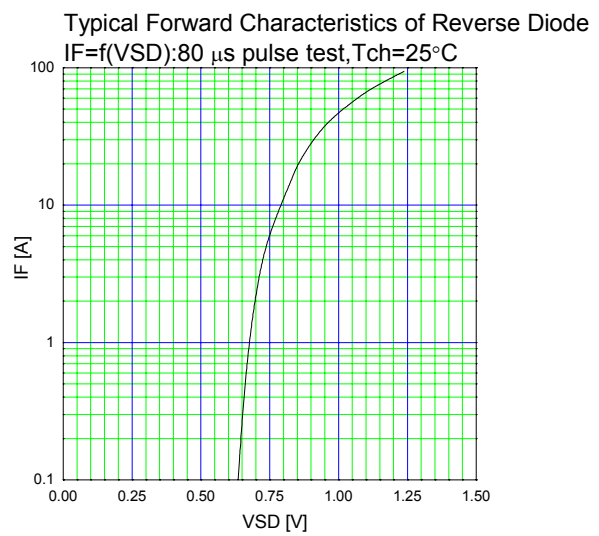
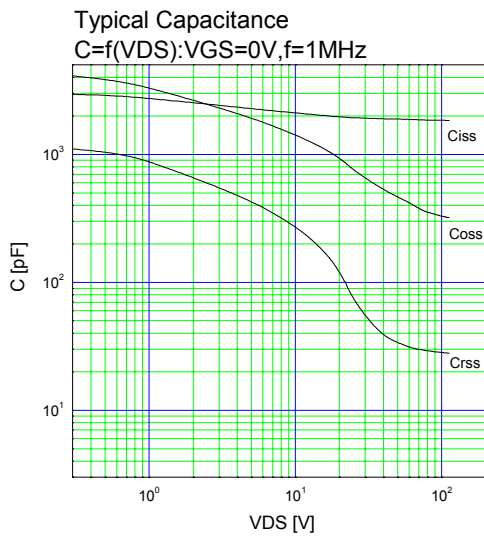
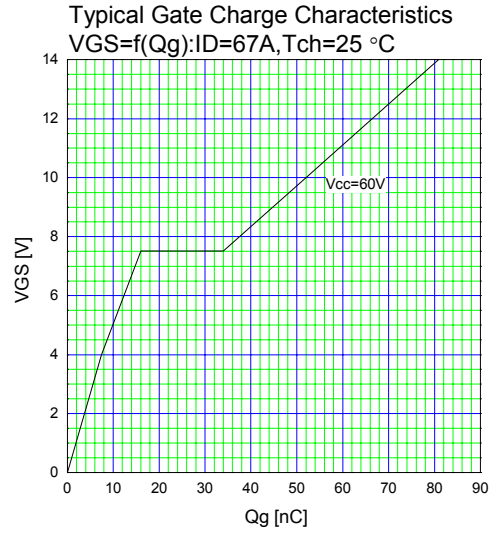
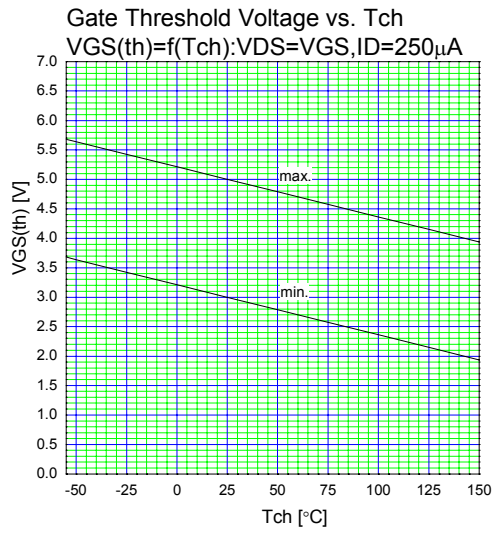

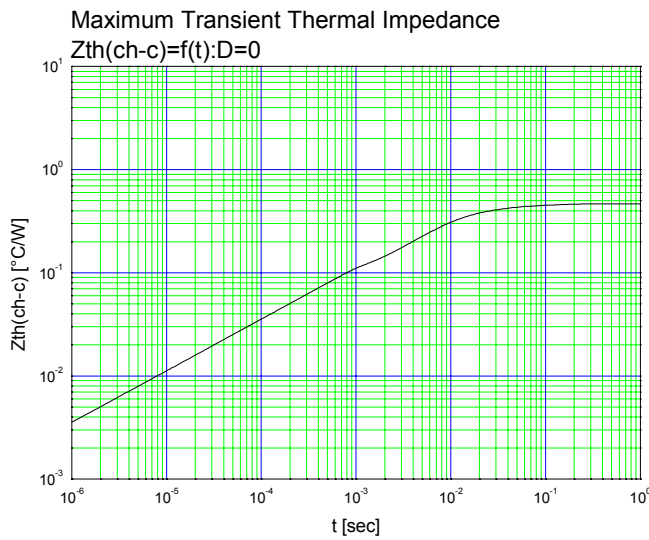
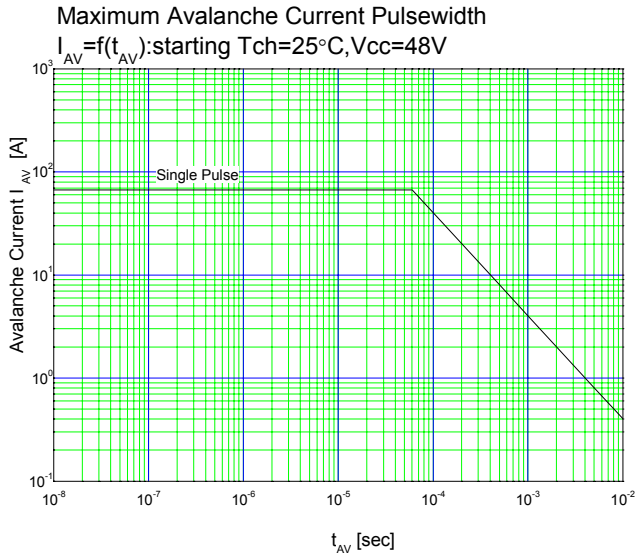

■ Outline Drawings [mm]

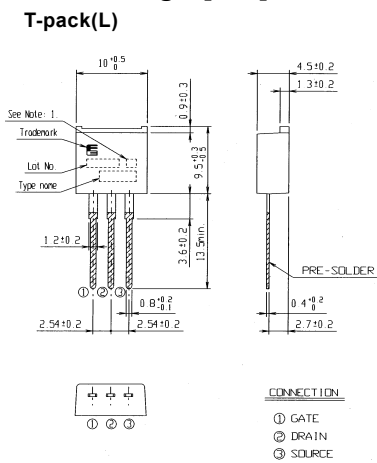

Note: 1. Guaranteed mark of avalanche ruggedness.

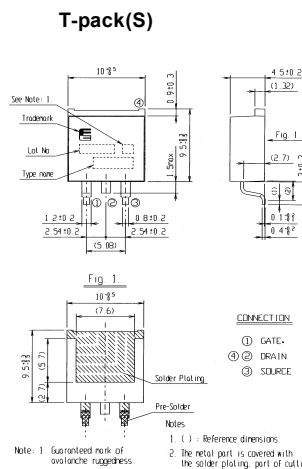

Note: 1. Guaranteed mark of avalanche ruggedness.

T-pack(SJ) [D2-pack]

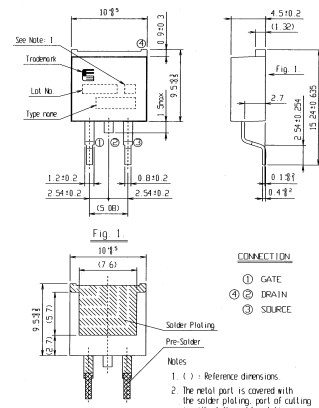

Note: 1. Guaranteed mark of avalanche ruggedness.

DIMENSIONS ARE IN MILLIMETERS.