

## Precision Adjustable Shunt Regulator

### FEATURES

- Trimmed Bandgap to 0.5%, 1% and 2%
- Wide Operating Current 1mA to 150mA
- Extended Temperature Range:  
0°C to 105°C
- Low Temperature Coefficient 30 ppm/°C
- Offered in TO-92, SOIC, SOT-89,  
SOT-23-5
- Improved Replacement in Performance for  
TL431
- Low Cost Solution

### APPLICATIONS

- Battery Operating Equipment
  - Adjustable Supplies
  - Switching Power Supplies
  - Error Amplifiers
  - Single Supply Amplifier
  - Monitors / VCRs / TVs
  - Personal Computers
- Now Available in Lead Free Packaging*

Refer to page 3 for pinouts.

### DESCRIPTION

The SPX431 is a 3-terminal adjustable shunt voltage regulator providing a highly accurate bandgap reference. The SPX431 acts as an open-loop error amplifier with a 2.5V temperature compensation reference. The SPX431's thermal stability, wide operating current (150mA) and temperature range (0°C to 105°C) makes it suitable for a variety of applications that require a low cost, high performance solution. SPX431A tolerance of 0.5% is proven to be sufficient to overcome all of the other errors in the system to virtually eliminate the need for trimming in the power supply manufacturer's assembly line and contribute a significant cost savings.

The output voltage may be adjusted to any value between  $V_{REF}$  and 36 volts with two external resistors. The SPX431 is available in TO-92, SOIC-8, SOT-89, and SOT-23-5 packages.

### TYPICAL APPLICATIONS CIRCUIT

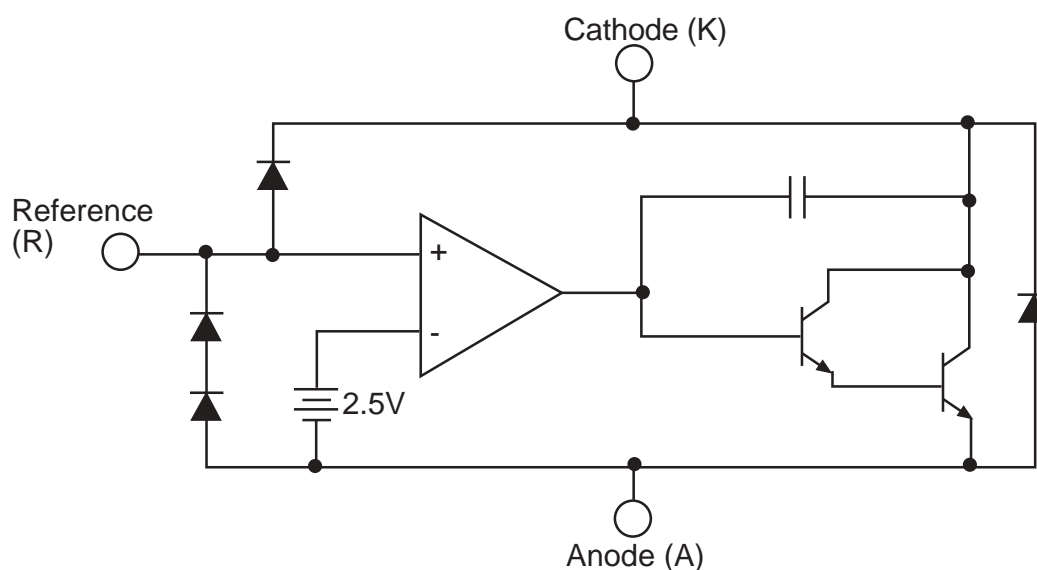

## ABSOLUTE MAXIMUM RATINGS

Cathode-Anode Reverse Breakdown $V_{KA}$	37V
Anode-Cathode Forward Current, (<10ms) $I_{AK}$	1A
Operating Cathode Current $I_{KA}$	150mA
Reference Input Current $I_{REF}$	10mA
Continuous Power Dissipation at 25°C $P_D$	
TO-92	775mW
SOT-23	200 mW
SOIC-8	750mW
SOT-89	1000mW

Junction Temperature $T_J$	150 °C
Storage Temperature $T_{STG}$	-65 to 150 °C

**NOTE:** Stresses greater than those listed under ABSOLUTE MAXIMUM RATINGS may cause permanent damage to the device. This is a stress rating only and functional operation of the device at these or any other conditions above those indicated in the operational sections of this specification is not implied. Exposure to absolute maximum rating conditions for extended periods may affect reliability.

## RECOMMENDED CONDITIONS

PARAMETER	SYMBOL	RATING	UNIT
Cathode Voltage	$V_{KA}$	$V_{REF}$ to 36	V
Cathode Current	$I_K$	10	mA

## TYPICAL THERMAL RESISTANCES

PACKAGE	$\theta_{JA}$	$\theta_{JC}$	TYPICAL DERATING
TO-92	160°C/W	80°C/W	6.3 mW/°C
SOT-23	575°C/W	150°C/W	1.7 mW/°C
SOIC-8	175°C/W	45°C/W	5.7 mW/°C
SOT-89	110°C/W	8°C/W	9.1 mW/°C

Typical deratings of the thermal resistances are given for ambient temperature >25°.

## ELECTRICAL CHARACTERISTICS

Electrical characteristics at 25°C  $I_K = 10mA$   $V_K = V_{REF}$ , unless otherwise specified.

PARAMETER	SYMBOL	FIGURE	CONDITIONS	MIN	TYP	MAX	UNITS
<b>SPX431A</b>							
Reference Voltage	$V_{REF}$	2	$T_J = 0^\circ\text{C to } 105^\circ\text{C}$	2.490	2.503	2.515	V
		2		2.469		2.536	V
$\Delta V_{REF}$ withTemp.*	TC	2			0.07	0.20	mV/°C
Ratio of Change in $V_{REF}$ to Cathode Voltage	$\frac{\Delta V_{REF}}{\Delta V_K}$	3	$V_{REF}$ to 10V 10V to 36V	-2.7 -2.0	-1.0 -0.4	0.3	mV/V
Reference Input Current	$I_{REF}$	3			0.7	4.0	$\mu\text{A}$
$I_{REF}$ Temp Deviation	$\Delta I_{REF}$	3	$T_J = 0^\circ\text{C to } 105^\circ\text{C}$		0.4	1.2	$\mu\text{A}$
Min $I_K$ for Regulation	$I_{K(MIN)}$	2			0.4	1.0	mA
Off State Leakage	$I_{K(OFF)}$	4	$V_{REF} = 0V, V_{KA} = 36V$		0.04	250	nA
Dynamic Output Impedance	$Z_{KA}$	2	$f_z = 1\text{kHz}$ $I_K = 1$ to 150mA		0.15	0.5	$\Omega$
<b>SPX431B</b>							
Reference Voltage	$V_{REF}$	2	$T_J = 0^\circ\text{C to } 105^\circ\text{C}$	2.470	2.495	2.520	V
		2		2.449		2.541	V
$\Delta V_{REF}$ withTemp.*	TC	2			0.07	0.20	mV/°C
Ratio of Change in $V_{REF}$ to Cathode Voltage	$\frac{\Delta V_{REF}}{\Delta V_K}$	3	$V_{REF}$ to 10V 10V to 36V	-2.7 -2.0	-1.0 -0.4	0.3	mV/V
Reference Input Current	$I_{REF}$	3			0.7	4.0	$\mu\text{A}$
$I_{REF}$ Temp Deviation	$\Delta I_{REF}$	3	$T_J = 0^\circ\text{C to } 105^\circ\text{C}$		0.4	1.2	$\mu\text{A}$
Min $I_K$ for Regulation	$I_{K(MIN)}$	2			0.4	1.0	mA
Off State Leakage	$I_{K(OFF)}$	4	$V_{REF} = 0V, V_{KA} = 36V$		0.04	500	nA
Dynamic Output Impedance	$Z_{KA}$	2	$f_z = 1\text{kHz}$ $I_K = 1$ to 150mA		0.15	0.5	$\Omega$

PARAMETER	SYMBOL	FIGURE	CONDITIONS	MIN	TYP	MAX	UNITS
<b>SPX431C</b>							
Reference Voltage	$V_{REF}$	2	$T_J = 0^\circ\text{C to } 105^\circ\text{C}$	2.445	2.495	2.545	V
$\Delta V_{REF}$ with Temp.*	TC	2				0.07	0.20
Ratio of Change in $V_{REF}$ to Cathode Voltage	$\frac{\Delta V_{REF}}{\Delta V_K}$	3	$V_{REF}$ to 10V 10V to 36V	-2.7 -2.0	-1.0 -0.4	0.3	mV/V
Reference Input Current	$I_{REF}$	3			0.7	4.0	$\mu\text{A}$
$I_{REF}$ Temp Deviation	$\Delta I_{REF}$	3	$T_J = 0^\circ\text{C to } 105^\circ\text{C}$		0.4	1.2	$\mu\text{A}$
Min $I_K$ for Regulation	$I_{K(MIN)}$	2			0.4	1.0	mA
Off State Leakage	$I_{K(OFF)}$	4	$V_{REF} = 0\text{V}, V_{KA} = 36\text{V}$		0.04	1000	nA
Dynamic Output Impedance	$Z_{KA}$	2	$f_z = 1\text{kHz}$ $I_K = 1 \text{ to } 150\text{mA}$		0.15	0.5	$\Omega$

Operating Range ( $T_J$ ) =  $-40^\circ\text{C to } 125^\circ\text{C}$ .

\* See appropriate test circuit (Figure 2)

### CALCULATING AVERAGE TEMPERATURE COEFFICIENT (TC)

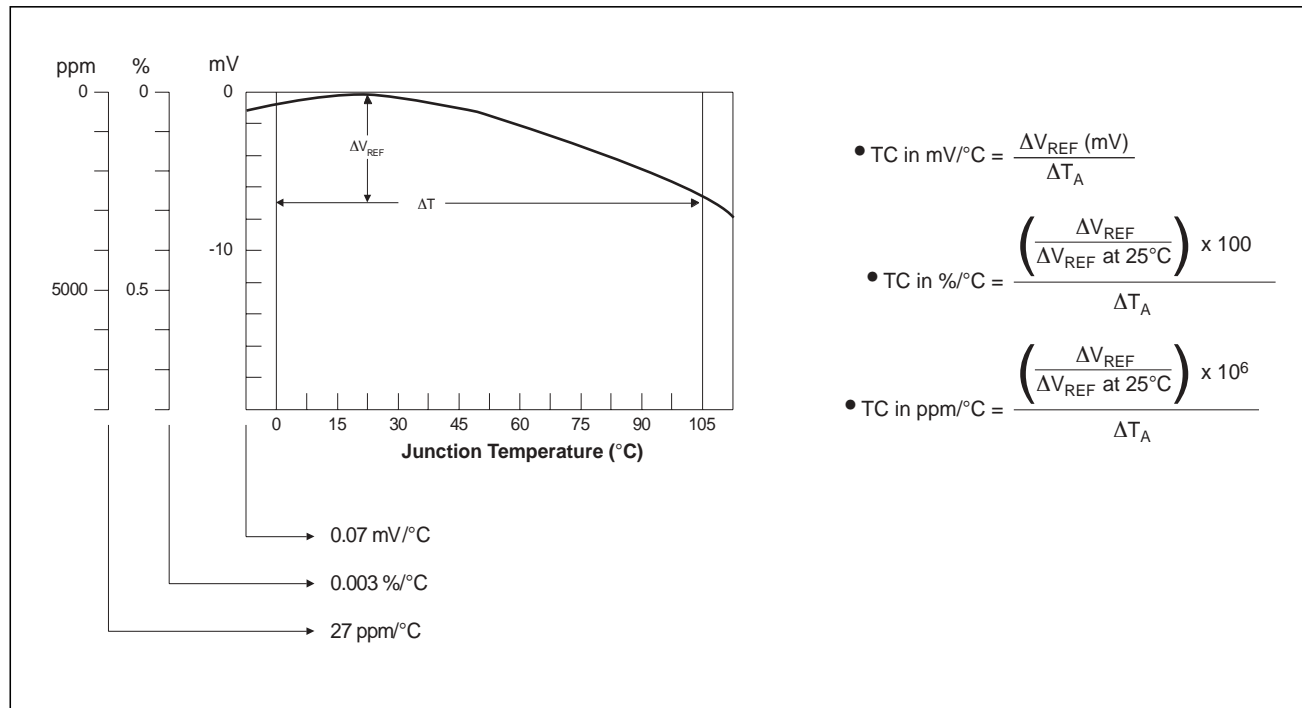
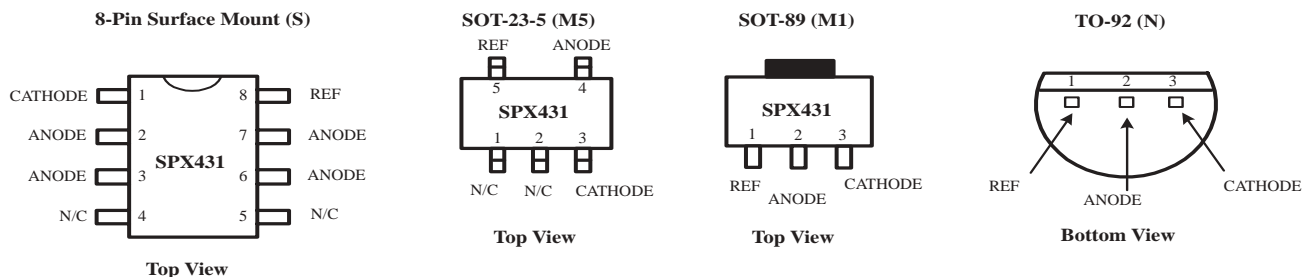

Figure 1.  $V_{REF}$  VS Temperature.

### PACKAGE PINOUTS



## TEST CIRCUITS

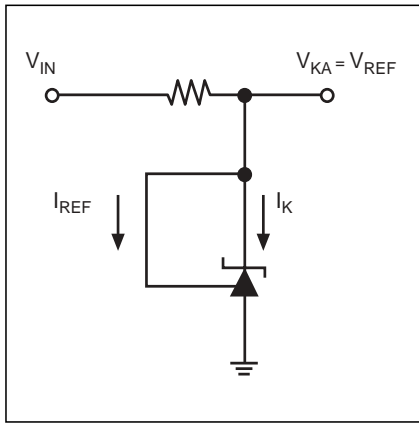

Figure 2. Test Circuit for  $V_{KA} = V_{REF}$

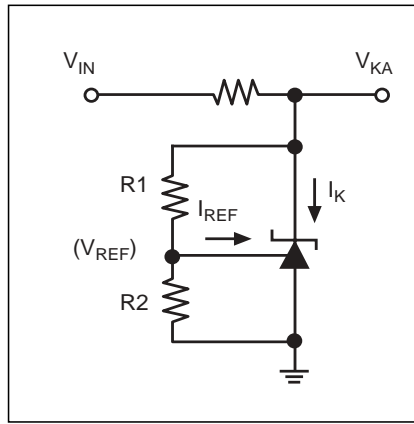

Figure 3. Test Circuit for  $V_{KA} > V_{REF}$

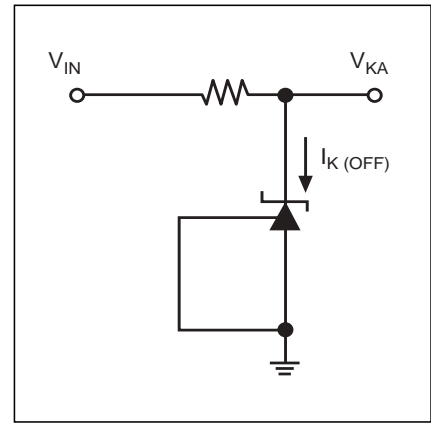

Figure 4. Test Circuit for  $I_{K(OFF)}$

## TYPICAL PERFORMANCE CHARACTERISTICS

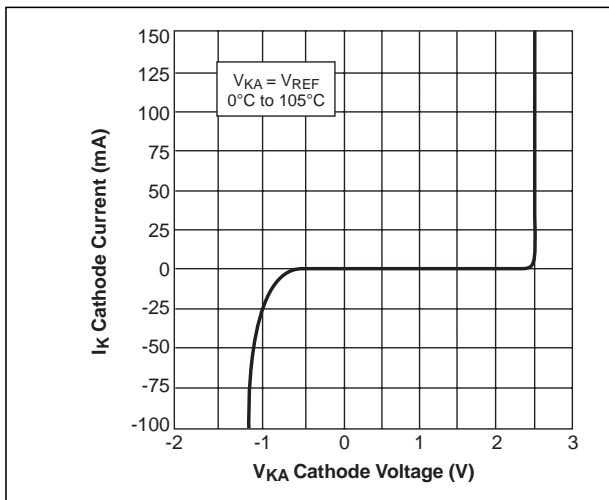

Figure 5. High Current Operating Characteristics

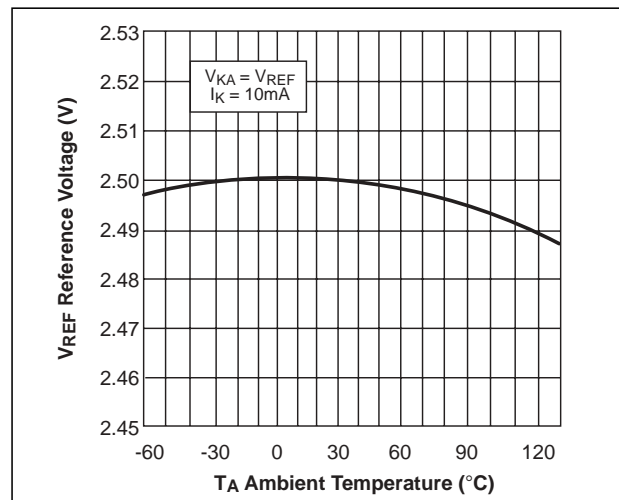

Figure 6. Reference Voltage VS Ambient Temperature

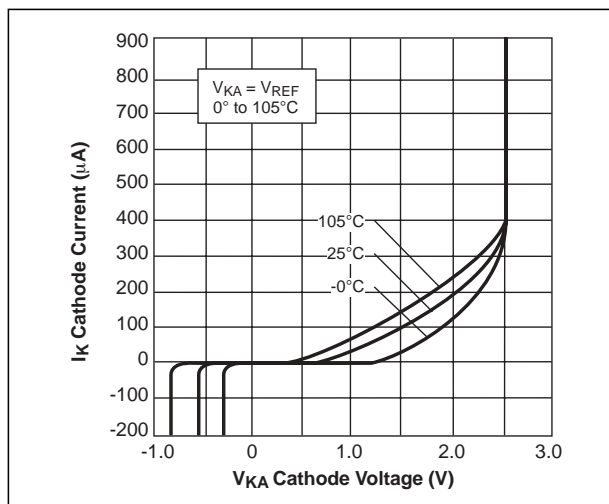

Figure 7. Low Current Operating Characteristics

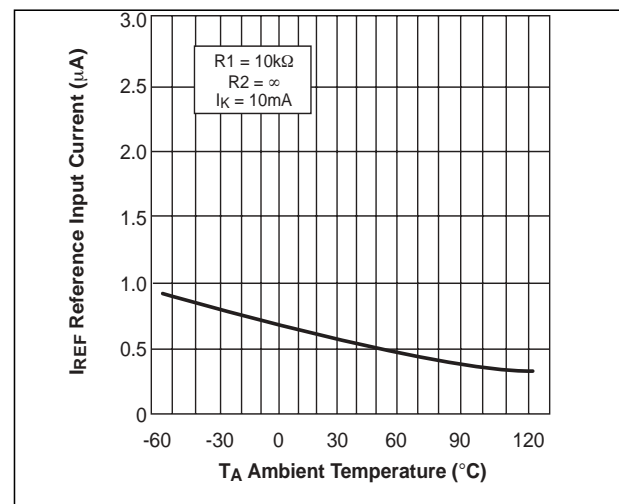

Figure 8. Reference Input Current VS Ambient Temperature

# TYPICAL PERFORMANCE CHARACTERISTICS (continued)

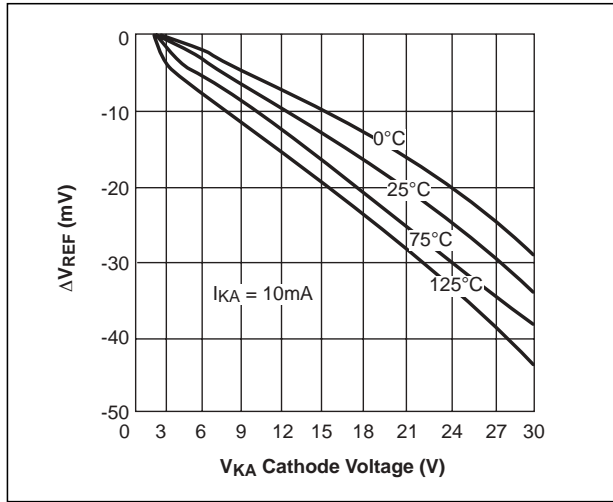

Figure 9. Reference Voltage Line Regulation VS Cathode Voltage and  $T_{AMBIENT}$

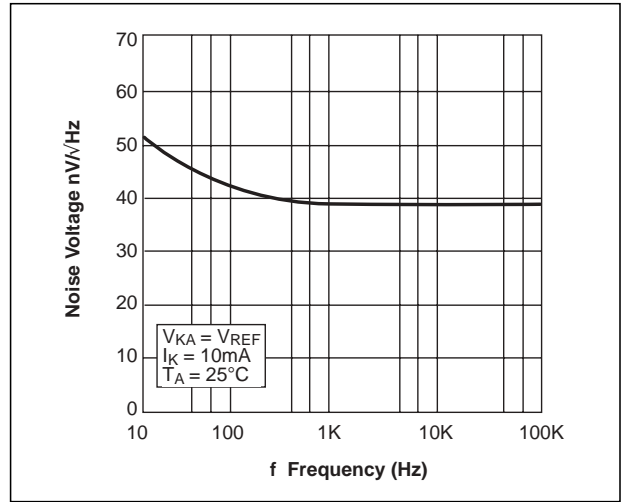

Figure 10. Noise Voltage VS Frequency

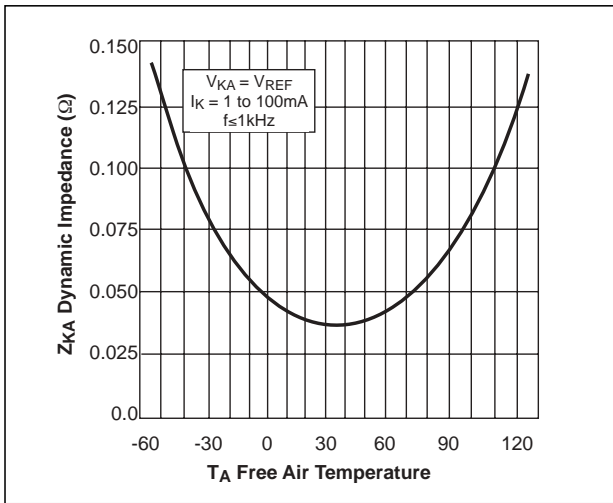

Figure 11. Low Frequency Dynamic Output Impedance VS  $T_{AMBIENT}$

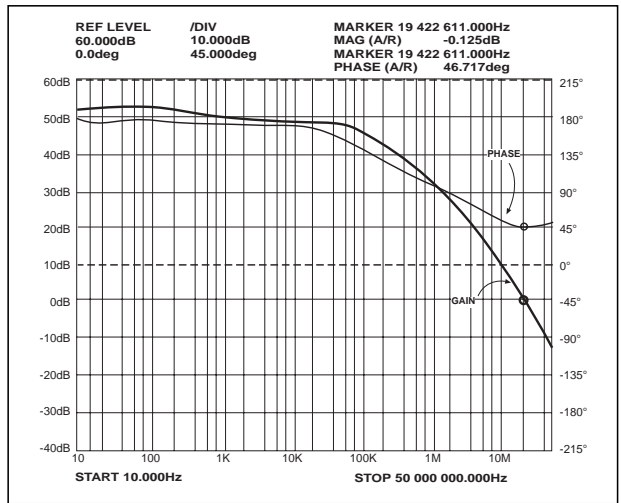

Figure 12. Small Signal Gain and Phase VS Frequency;  $I_K = 10mA, T_A = 25^\circ C$

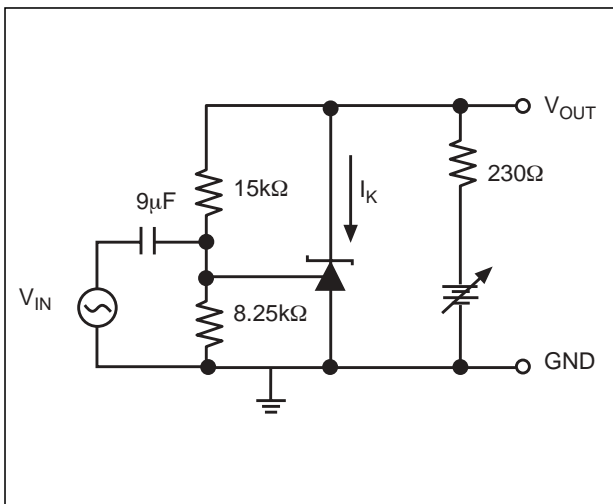

Figure 13. Test Circuit for Gain and Phase Frequency Response

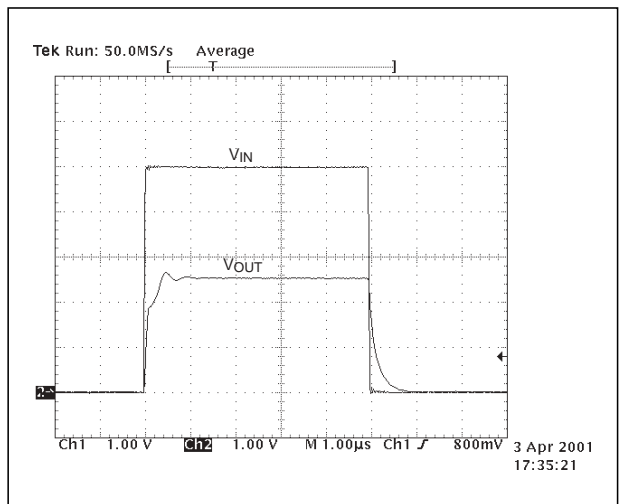

Figure 14.  $F_z = 100kHz, I_K = 10mA, T_A = 25^\circ C$

# TYPICAL PERFORMANCE CHARACTERISTICS (continued)

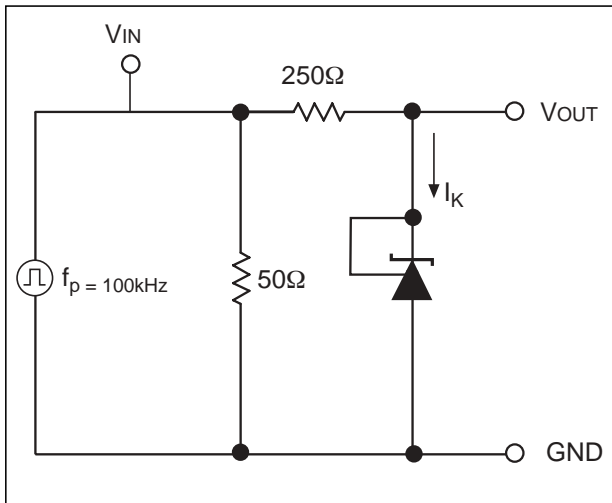

Figure 15. Test Circuit for Pulse Response

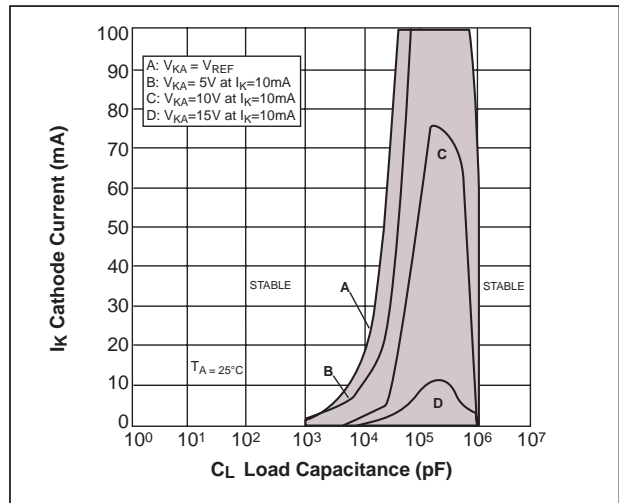

Figure 16. Stability Boundary Conditions

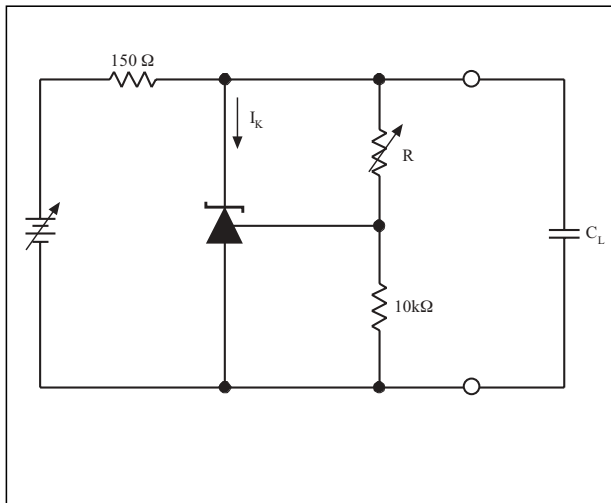

Figure 17. Test Circuit for Stability

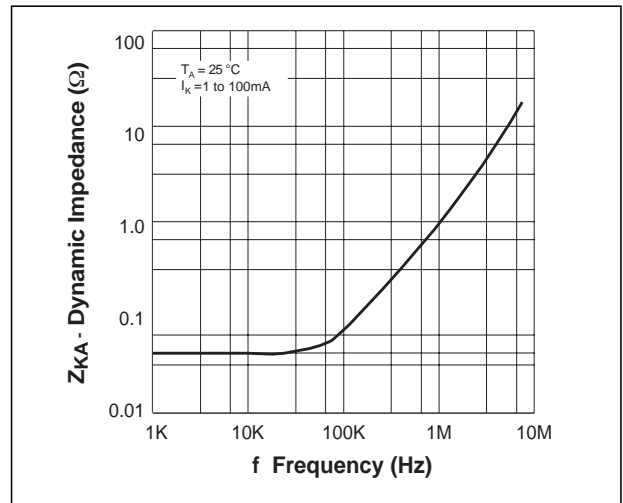

Figure 18. Dynamic Output Impedance  $T_A = 25^\circ\text{C}$ ,  $I_K = 1$  to  $100\text{mA}$

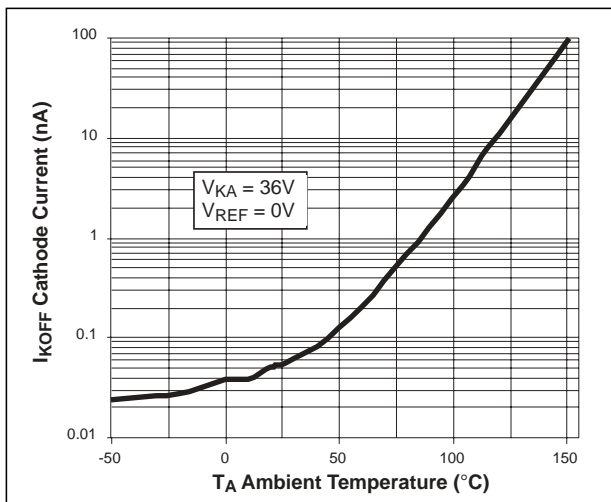

Figure 19. Off State Leakage

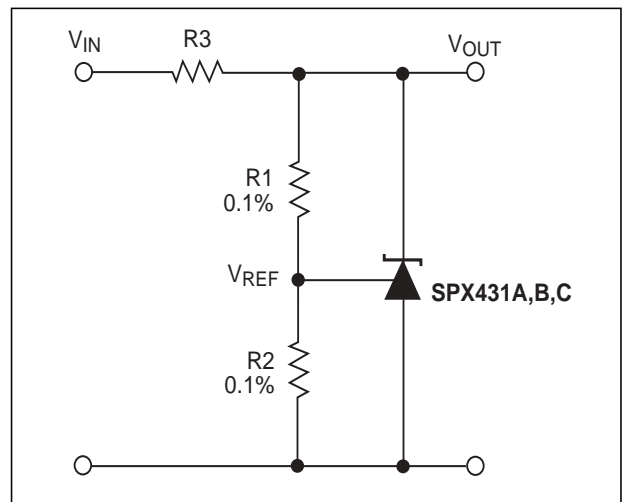

Figure 20. Shunt Regulator  $V_{OUT} = (1+R1/R2)V_{REF}$

## TYPICAL PERFORMANCE CHARACTERISTICS (continued)

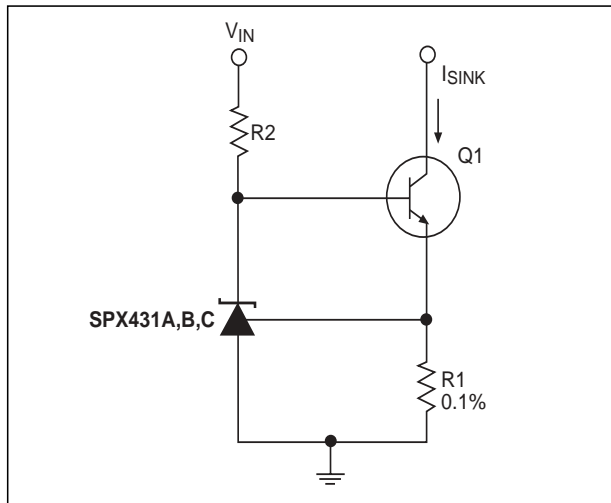

Figure 21. Constant Current Sink,  $I_{SINK} = V_{REF}/R1$

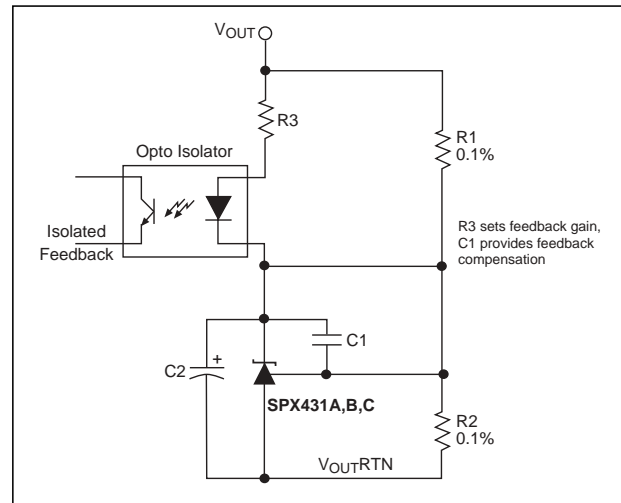

Figure 22. Reference Amplifier for Isolated Feedback in Off-Line DC-DC Converters  
R3 sets feedback gain, C1 provides feedback compensation

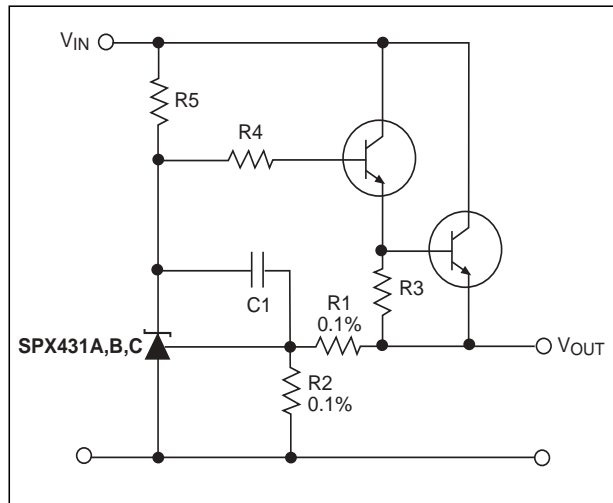

Figure 23. Precision High Current Series Regulator  
 $V_{OUT} = (1+R1/R2)V_{REF}$

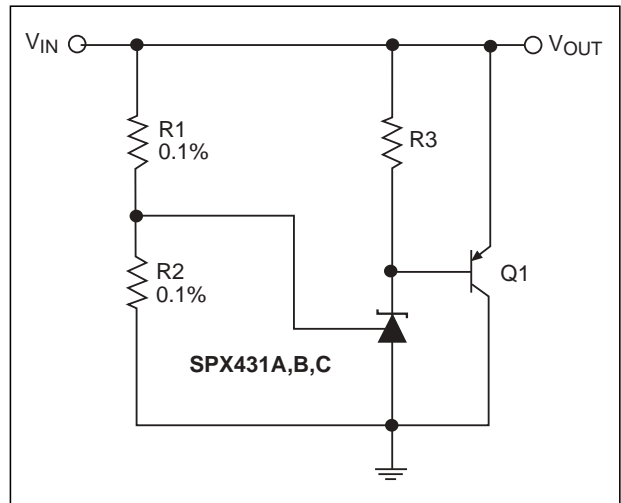

Figure 24. High Current Shunt regulator  
 $V_{OUT} = (1+R1/R2)V_{REF}$

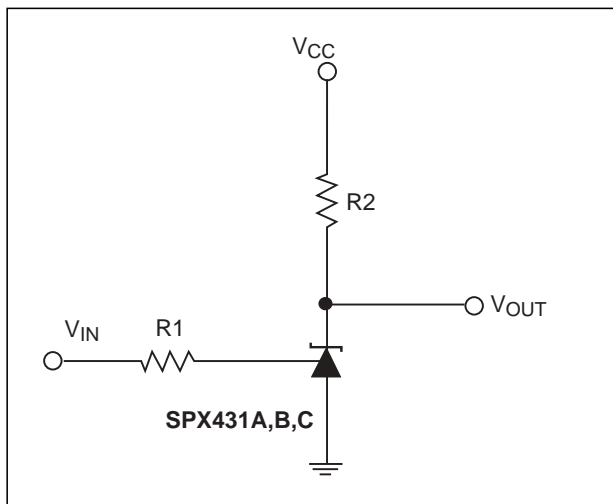
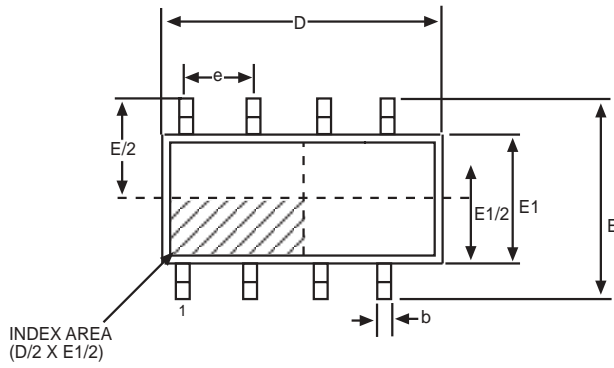
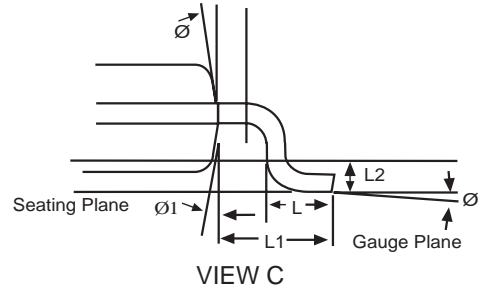

Figure 25. Single Supply Comparator with Temperature Compensated Threshold.  $V_{IN}$  threshold = 2.5V

\* Resistor values are chosen such that the effect to  $I_{REF}$  is negligible.



TOP VIEW



VIEW C

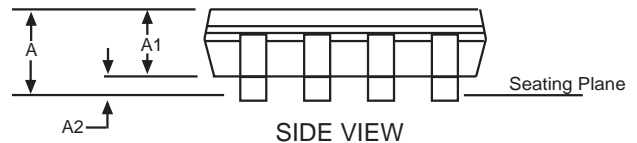

SIDE VIEW

8 Pin NSOIC JEDEC MO-012 (AA) Variation			
SYMBOL	MIN	NOM	MAX
A	1.35	-	1.75
A1	0.1	-	0.25
A2	1.25	-	1.65
b	0.31	-	0.51
c	0.17	-	0.24
D	4.90 BSC		
E	6.00 BSC		
E1	3.90 BSC		
e	1.27 BSC		
L	0.4	-	1.27
L1	1.04 REF		
L2	0.25 BSC		
Ø	0°	-	8°
Ø1	5°	-	15°

Note: Dimensions in (mm)

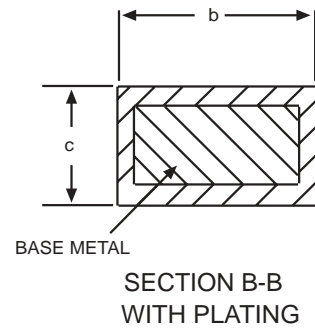
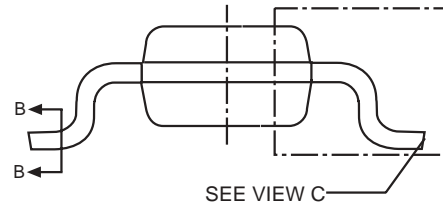

SECTION B-B WITH PLATING



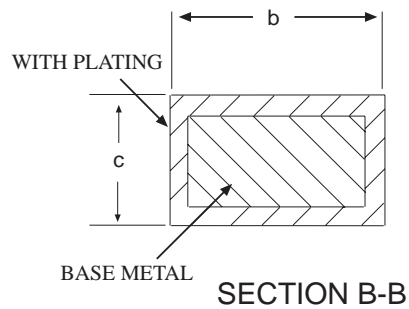
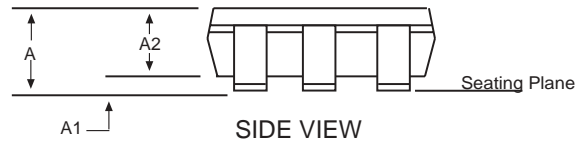
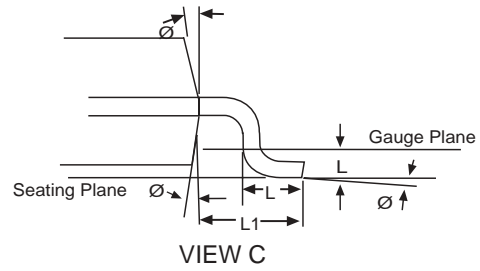
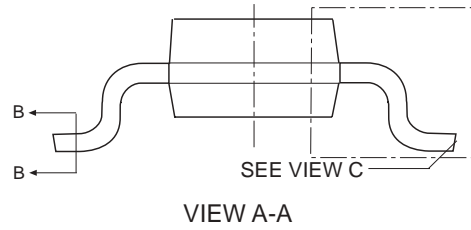
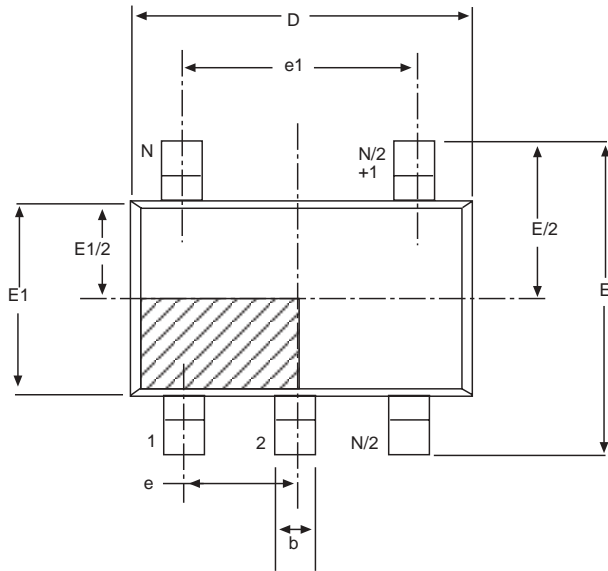

5 Pin SOT-23 JEDEC MO-178 (AA) Variation			
SYMBOL	MIN	NOM	MAX
A	-	-	1.45
A1	0	-	0.15
A2	0.9	1.15	1.3
b	0.3	-	0.5
c	0.08	-	0.22
D	2.90 BSC		
E	2.80 BSC		
E1	1.60 BSC		
e	0.95 BSC		
e1	1.90 BSC		
L	0.3	0.45	0.6
L1	0.60 REF		
L2	0.25 BSC		
$\theta$	0°	4°	8°
$\phi$	5°	10°	15°

Note: Dimensions in (mm)

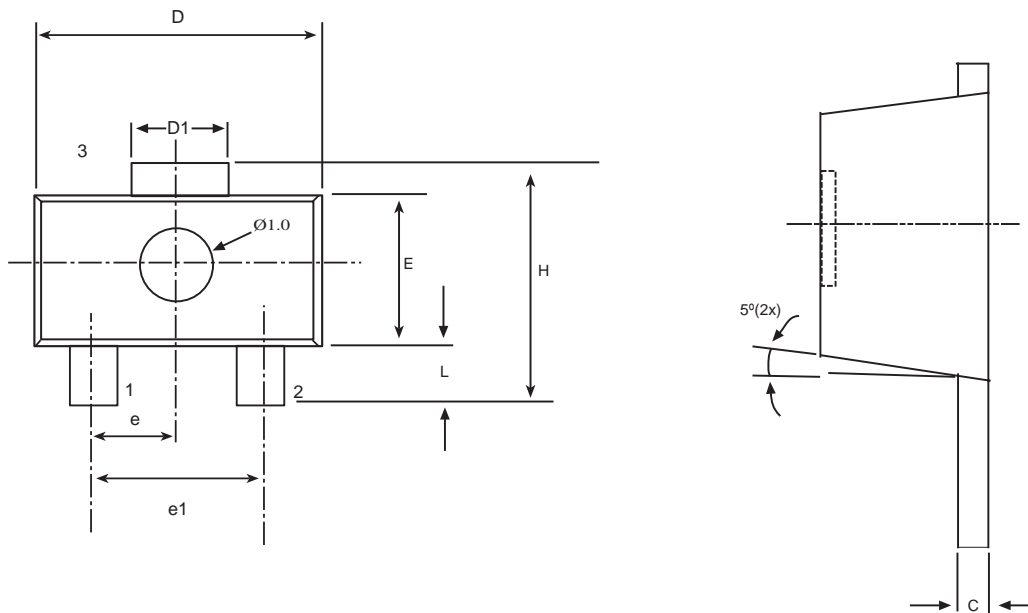

3 Pin SOT-89			
SYMBOL	MIN	NOM	MAX
b	0.36	0.42	0.48
L	0.8	-	1.2
b1	0.41	0.47	0.53
C	0.38	0.4	0.43
D	4.4	4.5	4.6
D1	1.4	1.6	1.75
H	3.94	-	4.25
E	2.4	2.5	2.6
e	1.45	1.5	1.55
e1	2.9	3	3.1

Note: Dimensions in (mm)

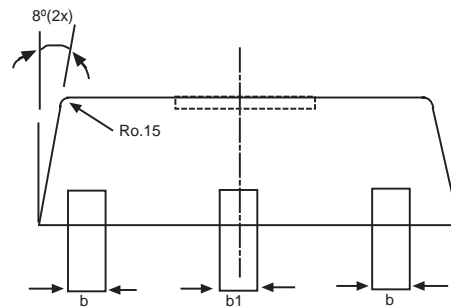

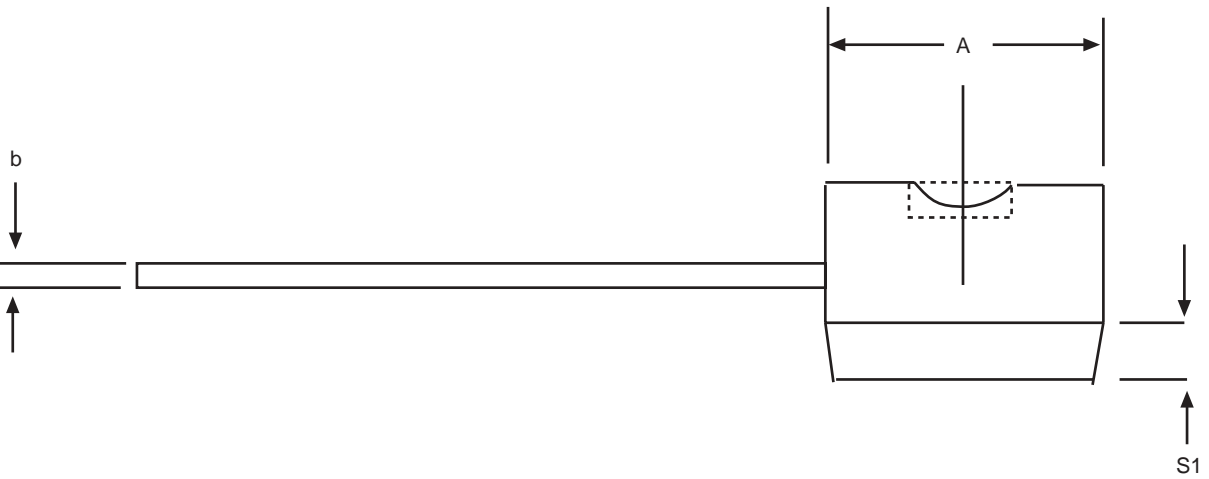
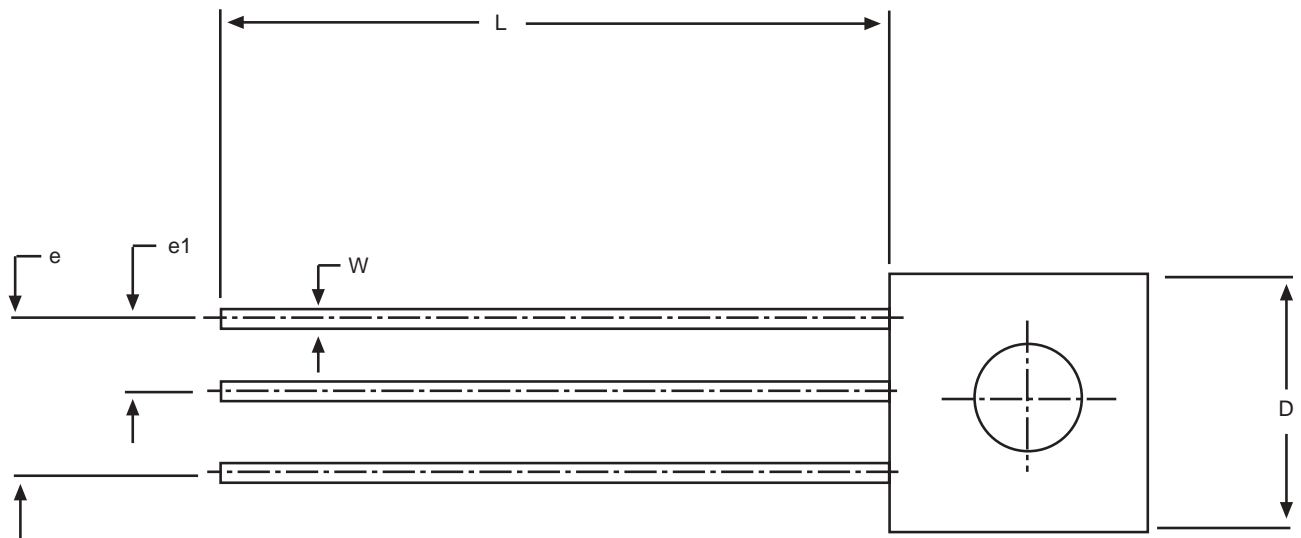

3 Pin TO-92			
SYMBOL	MIN	NOM	MAX
A	0.17	-	0.195
b	0.014	-	0.02
E	0.13	-	0.155
e	0.95	-	0.105
e1	0.045	-	0.055
L	0.5	-	0.61
R	0.085	-	0.095
S1	0.045	-	0.06
W	0.016	-	0.022
D	0.175	-	0.195
a	4°	-	6°

Note: Dimensions in (inches)

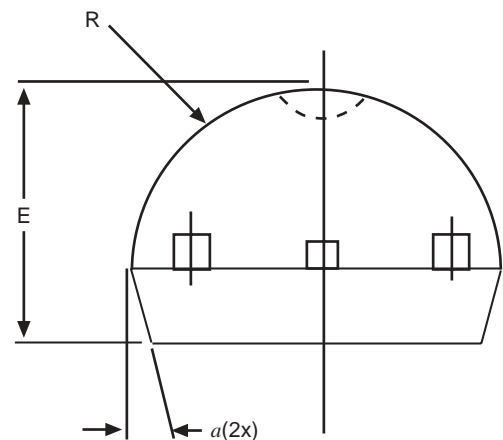

## ORDERING INFORMATION

PART NUMBER	ACCURACY	OUTPUT VOLTAGE	PACKAGES
SPX431AM5 .....	0.5% .....	2.503V .....	5-Pin SOT-23
SPX431AM5/TR .....	0.5% .....	2.503V .....	5-Pin SOT-23
SPX431AM1 .....	0.5% .....	2.503V .....	3-Pin SOT-89
SPX431AM1/TR .....	0.5% .....	2.503V .....	3-Pin SOT-89
SPX431AS .....	0.5% .....	2.503V .....	8-Pin SOIC
SPX431AS/TR .....	0.5% .....	2.503V .....	8-Pin SOIC
SPX431AN .....	0.5% .....	2.503V .....	3-Pin TO-92
SPX431AN/TR .....	0.5% .....	2.503V .....	3-Pin TO-92
SPX431BM5 .....	1.0% .....	2.495V .....	5-Pin SOT-23
SPX431BM5/TR .....	1.0% .....	2.495V .....	5-Pin SOT-23
SPX431BM1 .....	1.0% .....	2.495V .....	3-Pin SOT-89
SPX431BM1/TR .....	1.0% .....	2.495V .....	3-Pin SOT-89
SPX431BS .....	1.0% .....	2.495V .....	8-Pin SOIC
SPX431BS/TR .....	1.0% .....	2.495V .....	8-Pin SOIC
SPX431BN .....	1.0% .....	2.495V .....	3-Pin TO-92
SPX431BN/TR .....	1.0% .....	2.495V .....	3-Pin TO-92
SPX431CM5 .....	2.0% .....	2.495V .....	5-Pin SOT-23
SPX431CM5/TR .....	2.0% .....	2.495V .....	5-Pin SOT-23
SPX431CM1 .....	2.0% .....	2.495V .....	3-Pin SOT-89
SPX431CM1/TR .....	2.0% .....	2.495V .....	3-Pin SOT-89
SPX431CS .....	2.0% .....	2.495V .....	8-Pin SOIC
SPX431CS/TR .....	2.0% .....	2.495V .....	8-Pin SOIC
SPX431CN .....	2.0% .....	2.495V .....	3-Pin TO-92
SPX431CN/TR .....	2.0% .....	2.495V .....	3-Pin TO-92

Available in lead free packaging. To order add "-L" suffix to part number.

Example: SPX431AM5/TR = standard; SPX431AM5-L/TR = lead free

/TR = Tape and Reel

Pack quantity is 2,000 for TO-92 and 2,500 for SOT-23, SOT-89 and NSOIC.

[CLICK HERE TO ORDER SAMPLES](#)



### ANALOG EXCELLENCE

#### Sipex Corporation

**Headquarters and  
Sales Office**  
22 Linnell Circle  
Billerica, MA 01821  
TEL: (978) 667-8700  
FAX: (978) 670-9001  
e-mail: sales@sipex.com