

Precision 1.24V Shunt Voltage Reference

FEATURES

- Voltage Tolerance.....1% and 2%
- Wide Operating Current.....100 μ A to 15mA
- Low Temperature Coefficient.....50ppm/ $^{\circ}$ C
- Fixed Reverse Breakdown Voltage.....1.24V
- No Output Capacitance Required
- Two Terminal "Zener" Operation
- Improved Replacement for TL431

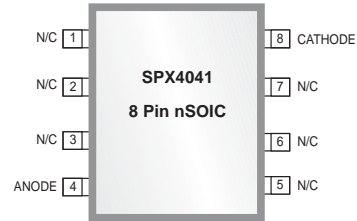

Now Available in Lead Free Packaging

APPLICATIONS

- Constant Current Source
- Digital Voltmeter
- Power Management
- Precision Regulators
- Battery Powered Equipment
- Instrumentation
- Automotive Electronics
- Data Acquisition Systems

DESCRIPTION

The SPX4041 is a 2-terminal, temperature compensated, band-gap voltage reference which provides a fixed 1.24V output for input currents between 160 μ A and 15mA. The bandgap voltage (1.24V) is independently laser trimmed from the output voltage to achieve a very low temperature coefficient, then the output voltage is trimmed to 1.24V. This trimming technique and the low temperature coefficient (A grade: 50 ppm/ $^{\circ}$ C) thin film resistor process gives a very stable device over the full temperature range. The SPX4041 is available in the sub miniature 3 pin SOT-23, 3 pin TO-92 or 8 pin NSOIC packages. The operating temperature is -40 $^{\circ}$ C to 85 $^{\circ}$ C. The SPX4041 advanced design eliminates the need for an external stabilized capacitor while insuring stability with any capacitive load, making it easy to use.

TYPICAL APPLICATIONS CIRCUIT

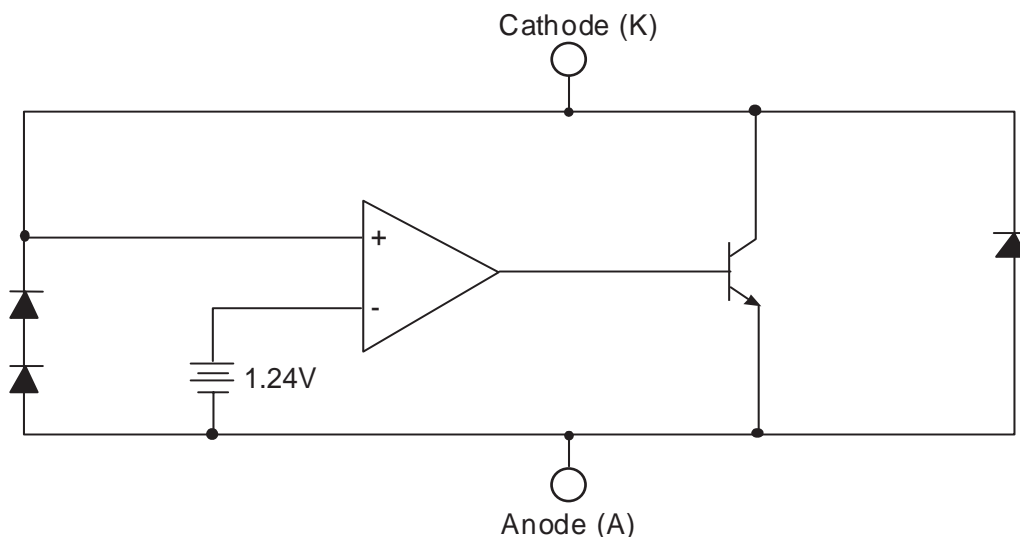

Figure 1: Block Diagram

ABSOLUTE MAXIMUM RATINGS

Stresses greater than those listed under ABSOLUTE MAXIMUM RATINGS may cause permanent damage to the device. This is a stress rating only and functional operation of the device at these or any other conditions above those indicated in the operational sections of this specification is not implied. Exposure to absolute maximum rating conditions for extended periods may affect reliability.

Reverse Current (I_{KA}) 20mA
 Forward Current (I_{AK}) 10mA
 Operating Temperature Range (T_A) -40 to +85°C
 Junction Temperature (T_J) 150°C
 Storage Temperature (T_{STG}) - 65 to 150°C
 Lead Temperature (Soldering 10 sec.), T_L 300°C

ELECTRICAL CHARACTERISTICS $I_{IN} = 1000\mu A, T_A = 25^\circ C$, unless otherwise specified.

PARAMETER	CONDITIONS	SPX4041A			SPX4041			UNIT
		MIN.	TYP.	MAX.	MIN.	TYP.	MAX.	
Reverse Breakdown Voltage	$I_R=500\mu A$		1.24			1.24		V
Reverse Breakdown Tolerance	$I_R=500\mu A$ $-40^\circ C \leq T_A \leq 85^\circ C$			± 12 ± 29			± 25 ± 49	mV
Dynamic Output Impedance			0.60	2.00		0.60	2.00	Ω
Noise Voltage	$0.1kHz \leq f \leq 10Hz$		15			15		μV_{PP}
Temperature Coefficient	Note 1			100			100	ppm/°C
Turn-on Setting	0.1% of V_{OUT}		30			30		μs
Temperature Range (T_A)		-40		85	-40		85	°C
Operating Current Range		0.5		5.0 15.0	0.5		5.0 15.0	mA
Thermal Resistance	TO-92 θ_{JA} TO-92 θ_{JC} SOIC-8 θ_{JA} SOIC-8 θ_{JC} SOT-23 θ_{JA} SOT-23 θ_{JC}		160 80 175 45 575 150			160 80 175 45 575 150		°C/W

Note 1. Three-point measurement guarantees the error band over the specified temperature range.

*CALCULATING AVERAGE TEMPERATURE COEFFICIENT (TC)

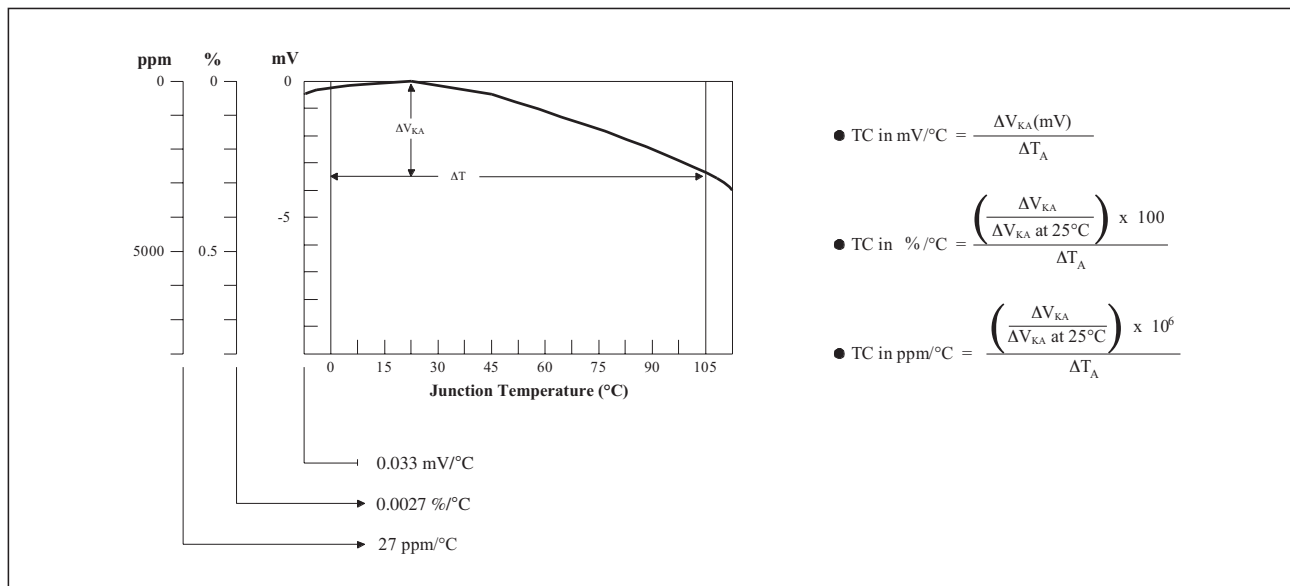

Figure 2. V_{REF} vs. Temperature

TYPICAL PERFORMANCE CHARACTERISTICS

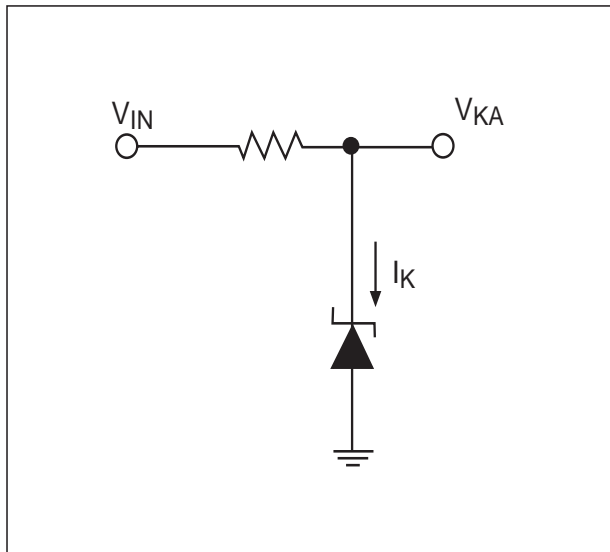

Figure 3. Test Circuit for $V_{KA} = V_{REF}$

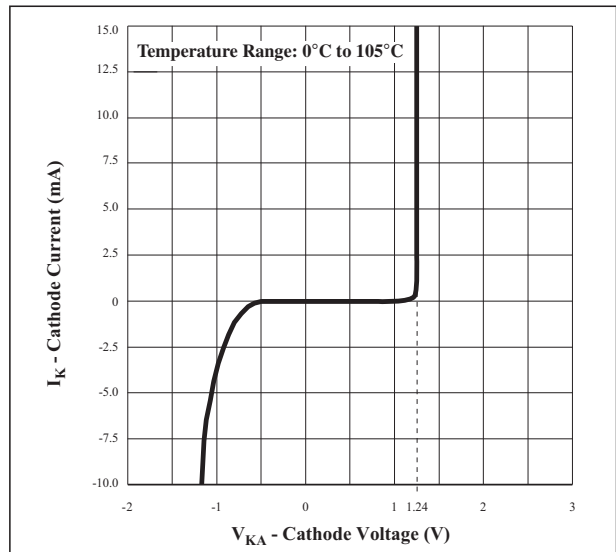

Figure 4. High Current Operating Characteristics

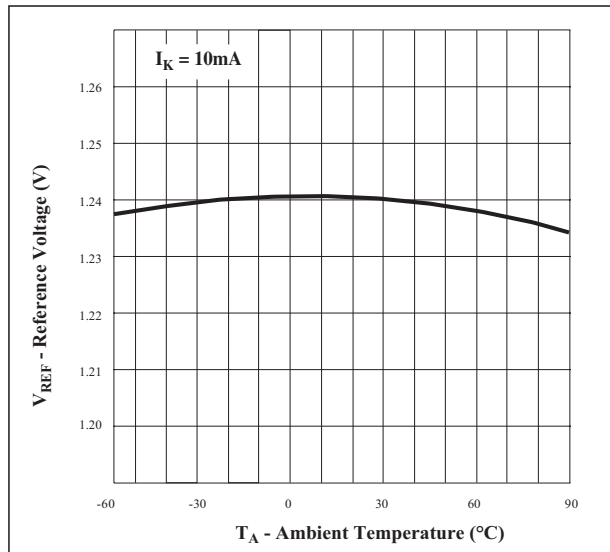

Figure 5. Reference Voltage vs. Ambient Temperature

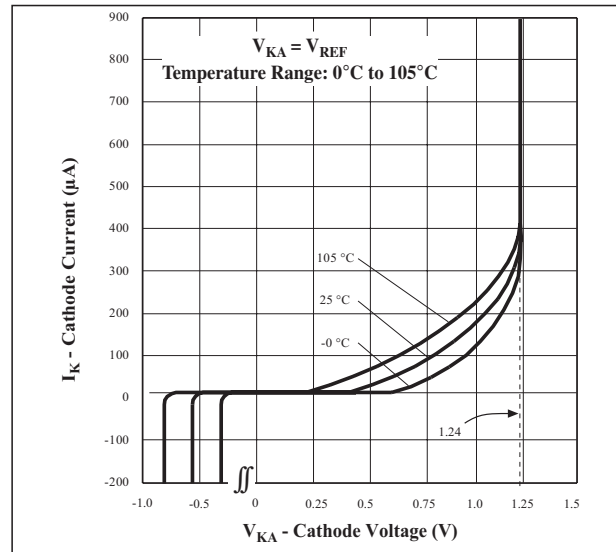

Figure 6. Low Current Operating Characteristics

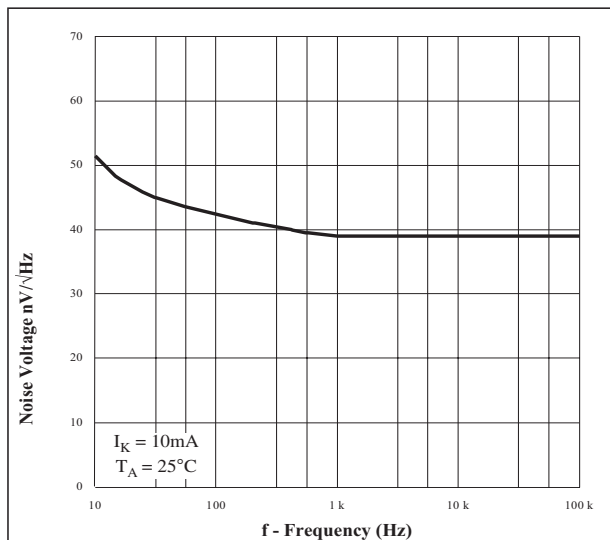

Figure 7. Noise Voltage vs Frequency

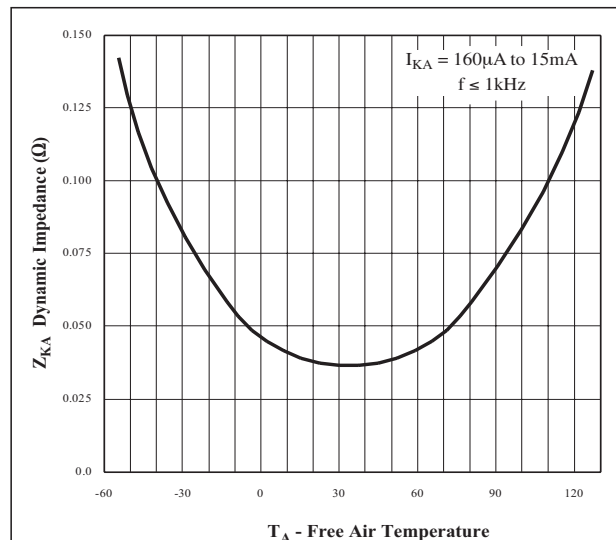

Figure 8. Low Frequency Dynamic Output Impedance vs T_A

TYPICAL PERFORMANCE CHARACTERISTICS

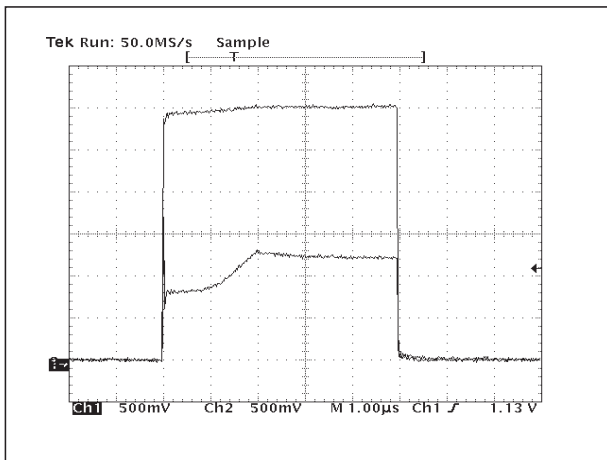

Figure 9. Frequency=100kHz, $I_K=10\text{mA}$, $T_A=25^\circ\text{C}$

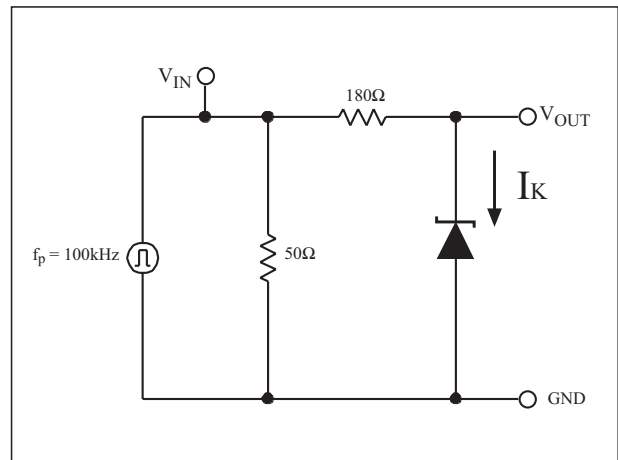

Figure 10. Test Circuit for Pulse Response

APPLICATION INFORMATION

This device is designed for stable operation and has no need of an external capacitor. The reference remains stable if a bypass capacitor is used.

SOT-23

The SPX4041 in the SOT-23 package has a parasitic Schottky diode between pin 3 and pin 1. Pin 1 of SOT-23 must float or be connected to pin 3.

Conventional Shunt Regulator

In a conventional shunt regulator application (see Figure 11), an external series resistor (R_S) is connected between the supply voltage and the SPX4041. R_S determines the current that flows through the load (I_L) and the reference (I_Q). Since

load current and supply voltage may vary, R_S should be small enough to supply at least the minimum acceptable I_Q to the reference even when the supply voltage is at its minimum and the load current is at its maximum value. When the supply voltage is at its maximum and I_L is at its minimum, R_S should be large enough so that the current flowing through the SPX4041 is less than 15mA.

R_S is determined by the supply voltage (V_S), the load and operating current (I_L and I_Q), reference's reverse breakdown voltage (V_R).

$$R_S = (V_S - V_R)/(I_L + I_Q)$$

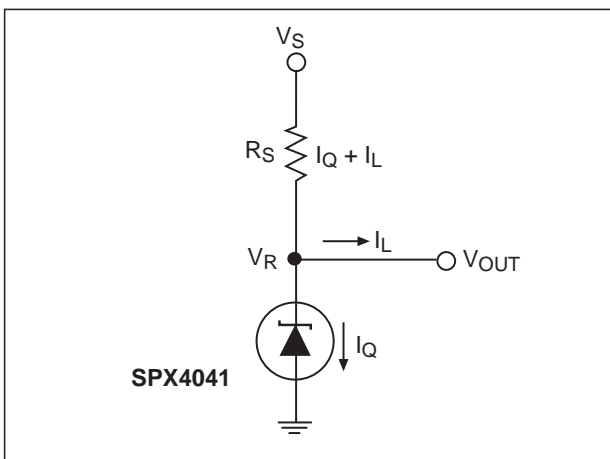

Figure 11. SPX4041 Fixed Shunt Regulator

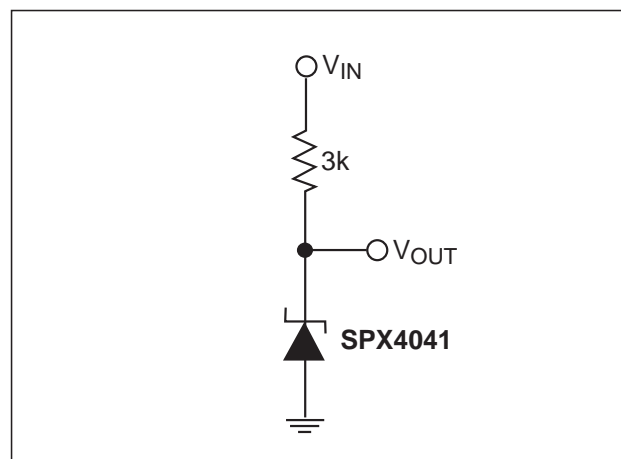

Figure 12 1.24V Reference Circuit

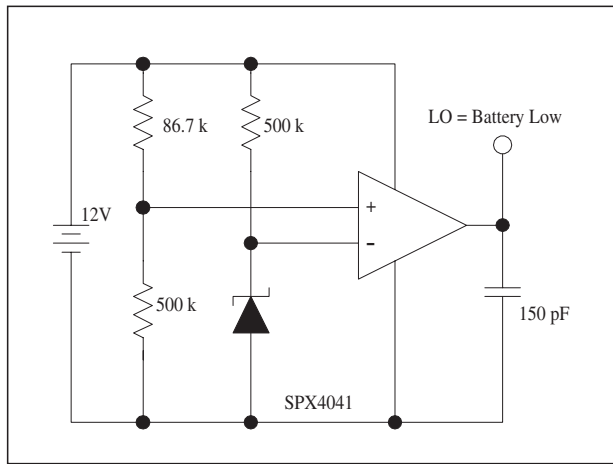

Figure 13. Low Battery Detector

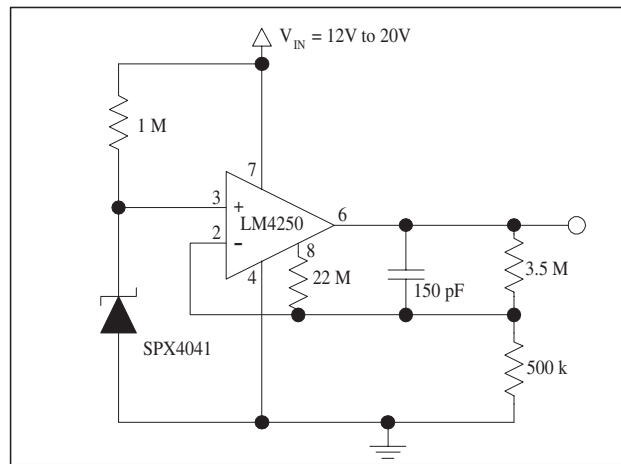
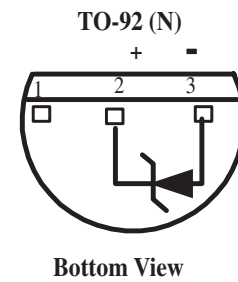
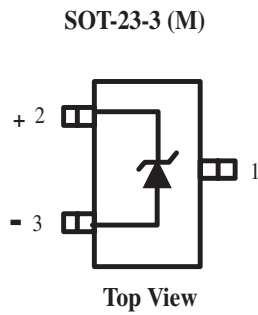
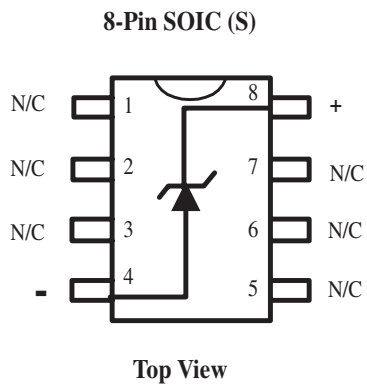
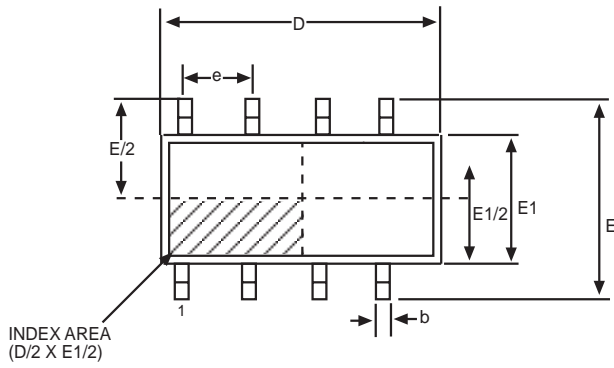

Figure 14. Micropower 10V Reference

PACKAGE PINOUTS





TOP VIEW

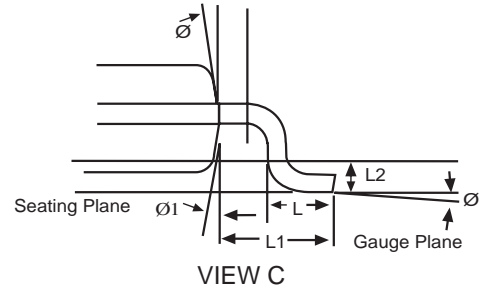

VIEW C

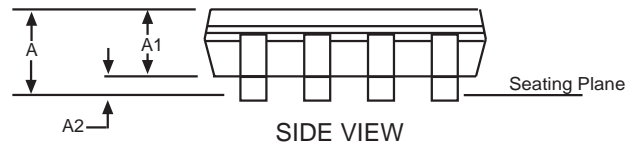

SIDE VIEW

8 Pin NSOIC JEDEC MO-012 (AA) Variation			
SYMBOL	MIN	NOM	MAX
A	1.35	-	1.75
A1	0.1	-	0.25
A2	1.25	-	1.65
b	0.31	-	0.51
c	0.17	-	0.24
D	4.90 BSC		
E	6.00 BSC		
E1	3.90 BSC		
e	1.27 BSC		
L	0.4	-	1.27
L1	1.04 REF		
L2	0.25 BSC		
Ø	0°	-	8°
Ø1	5°	-	15°

Note: Dimensions in (mm)

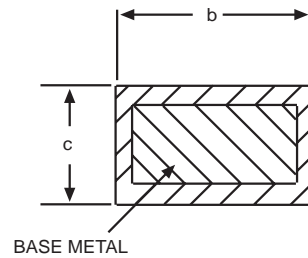
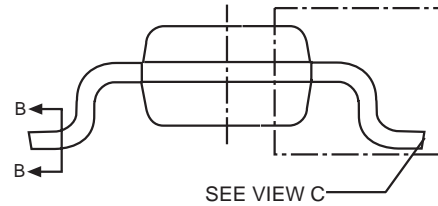

SECTION B-B WITH PLATING

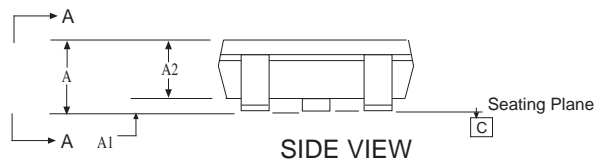
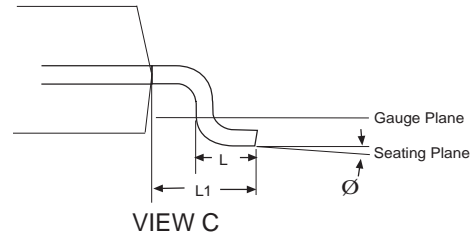
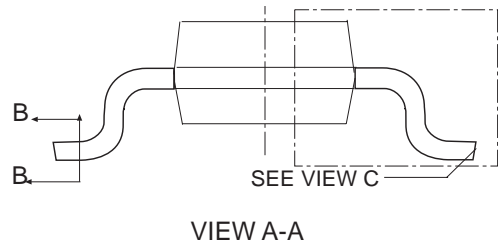
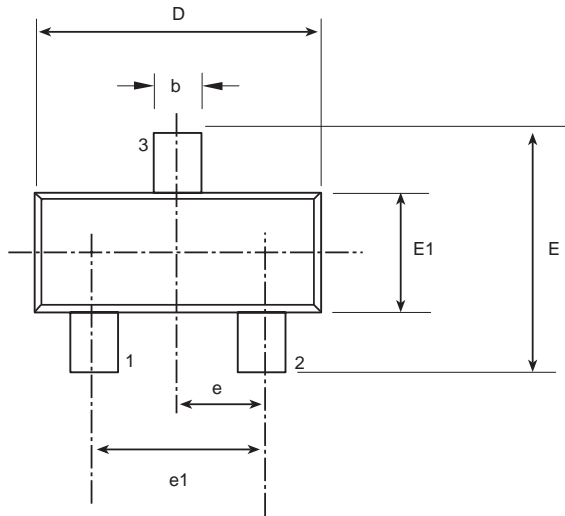

3 Pin SOT-23 JEDEC TO-236 (AB) Variation			
SYMBOL	MIN	NOM	MAX
A	0.89	-	1.12
A1	0.01	-	0.1
A2	0.88	0.95	1.02
b	0.3	-	0.5
c	0.08	-	0.2
D	2.8	2.9	3.04
e	0.95 BSC		
e1	1.90 BSC		
E	0.95	-	2.64
E1	1.2	1.3	1.4
L	0.4	0.5	0.6
L1	0.54 REF		
Ø	0°	-	8°

Note: Dimensions in (mm)

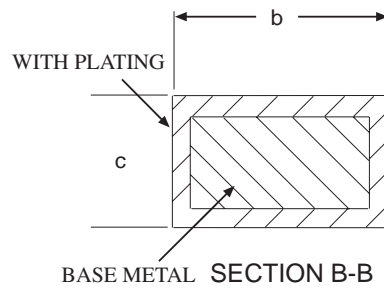

PACKAGE: 3 PIN TO-92

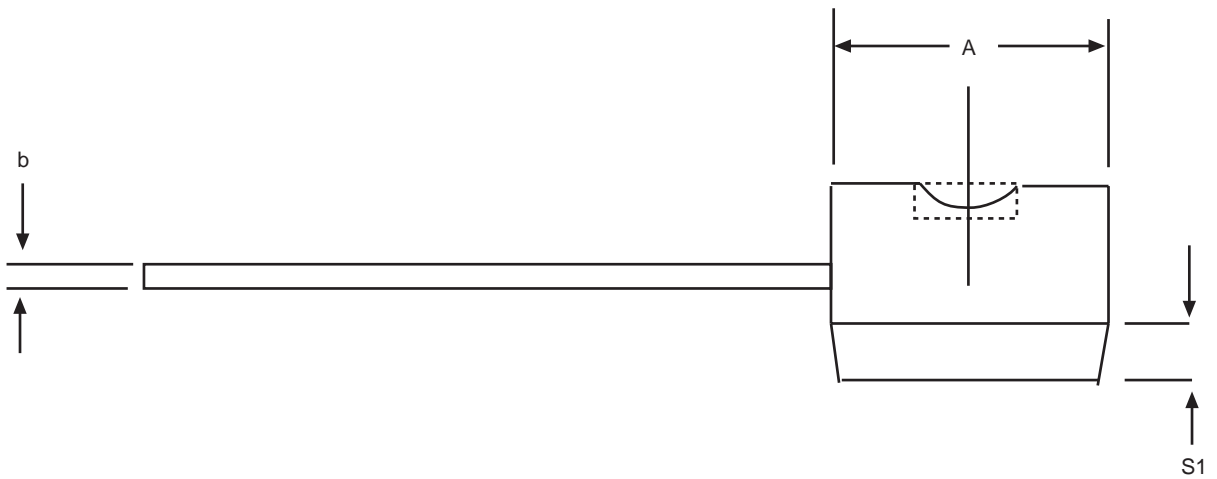
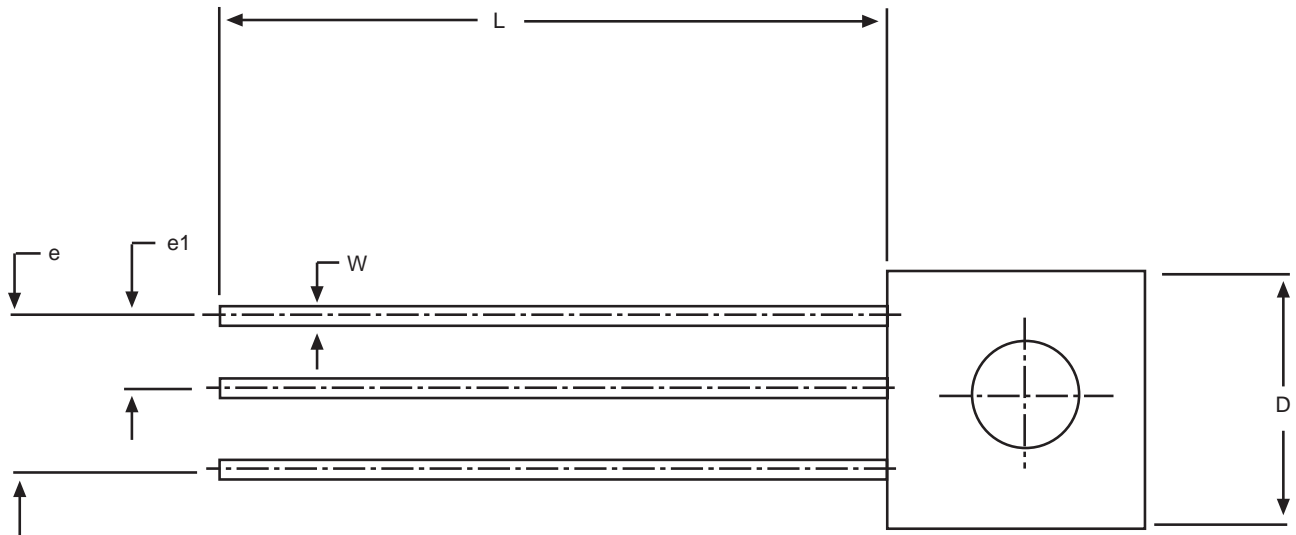

3 Pin TO-92			
SYMBOL	MIN	NOM	MAX
A	0.17	-	0.195
b	0.014	-	0.02
E	0.13	-	0.155
e	0.95	-	0.105
e1	0.045	-	0.055
L	0.5	-	0.61
R	0.085	-	0.095
S1	0.045	-	0.06
W	0.016	-	0.022
D	0.175	-	0.195
a	4°	-	6°

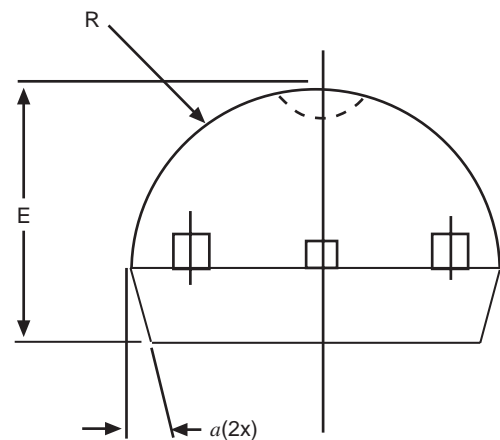

Note: Dimensions in (inches)

ORDERING INFORMATION

Part Number	Accuracy	Output Voltage	Package Type
SPX4041AM	1.0%	1.24V	3-Pin SOT-23
SPX4041AM/TR	1.0%	1.24V	3-Pin SOT-23
SPX4041AS	1.0%	1.24V	8-Pin NSOIC
SPX4041AS/TR	1.0%	1.24V	8-Pin NSOIC
SPX4041AN	1.0%	1.24V	3-Pin TO-92
SPX4041AN/TR	1.0%	1.24V	3-Pin TO-92
SPX4041M	2.0%	1.24V	3-Pin SOT-23
SPX4041M/TR	2.0%	1.24V	3-Pin SOT-23
SPX4041S	2.0%	1.24V	8-Pin NSOIC
SPX4041S/TR	2.0%	1.24V	8-Pin NSOIC
SPX4041N	2.0%	1.24V	3-Pin TO-92
SPX4041N/TR	2.0%	1.24V	3-Pin TO-92

Available in lead free packaging. To order add "-L" suffix to part number.

Example: SPX4041S/TR = standard; SPX4041S-L/TR = lead free

/TR = Tape and Reel

Pack quantity is 2,000 for TO-92, 2,500 for NSOIC and SOT-23.

→ [CLICK HERE TO ORDER SAMPLES](#) ←



ANALOG EXCELLENCE

Sipex Corporation

Headquarters and Sales Office:

233 Hillview Dr
Milpitas, CA 95035
TEL: (408) 934-7500
FAX: (408) 935-7600