

RS-232/RS-422 Line Drivers/Receivers

- RS-232 and RS-422 on One Chip
- Multiple Drivers and Receivers
- Software-selectable Modes
- Loopback for Self-Testing
- Short-circuit Protected
- Single-width 24-pin DIP and 28-pin SOIC Packages



DESCRIPTION...

The **SP304** is an enhanced-performance version of the **Sipex SP302** RS-232 and RS-422 protocol line drivers and receivers. It is pin-for-pin compatible with the **SP302**, and in any configuration, fully meets the requirements of the EIA RS-232D and RS-422 data communication standards. A loopback test mode is provided. The **SP304** is available in 24-pin single width plastic DIP, and 28-pin SOIC packages for commercial and industrial temperature range operation.

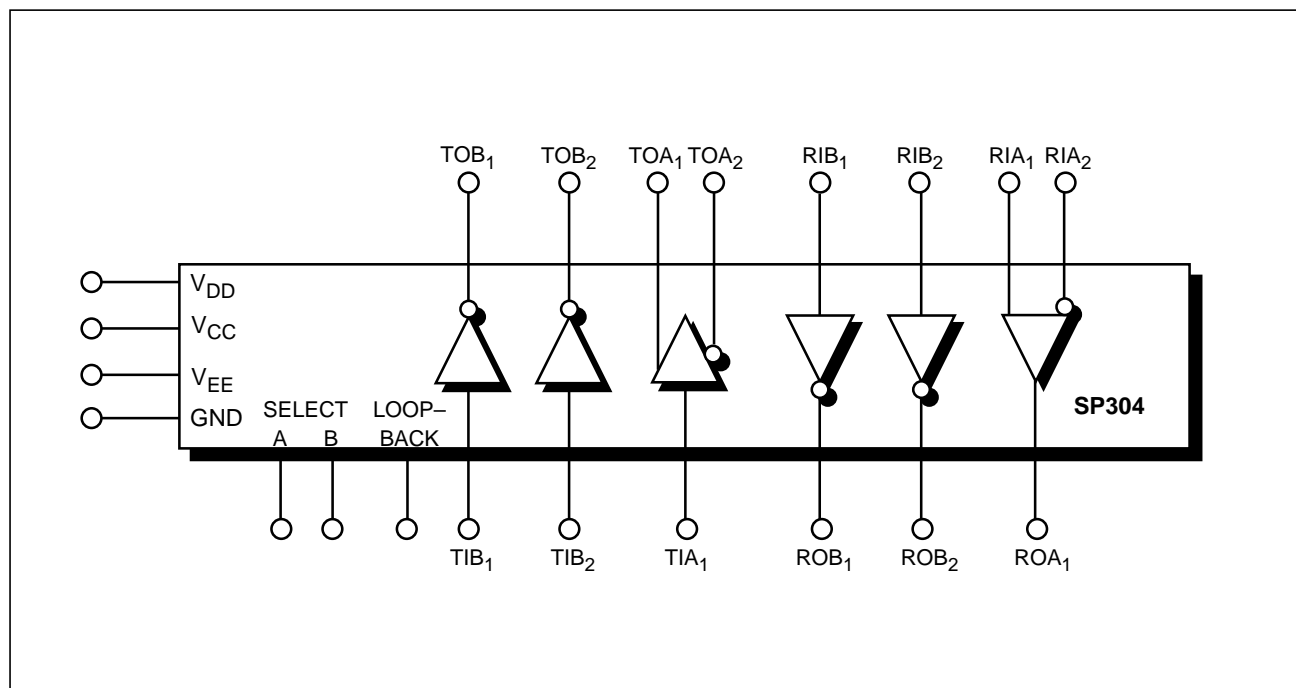

SPECIFICATIONS

($T_{MIN} \leq T_A \leq T_{MAX}$ and nominal supply voltages unless otherwise noted)

PARAMETER	MIN.	TYP.	MAX.	UNITS	CONDITIONS
RS-232 DRIVER					
TTL Input Level					
V_{IL}	0		0.8	V	
V_{IH}	2.0			V	
High Level Output	+5.0			V	$R_L = 3k\Omega, V_{IN} = 0.8V$
Low Level Output			-5.0	V	$R_L = 3k\Omega, V_{IN} = 2.0V$
Short Circuit Current			± 30	mA	$V_{OUT} = 0V$
Loopback Output Voltage		-1.5		V	$R_L = 3k\Omega, V_{EE} = -12.0V$; Note 1
Slew rate			30	V/ μs	$C_L = 50pF, R_L = 3k\Omega; T_A = 25^\circ C$
Transition Time		3		μs	V_{OUT} from +3V to -3V or -3V to +3V
Maximum Transmission Rate	200			kbps	
RS-232 RECEIVER					
Input Voltage Range	-15		+15	V	Note 6
Input High Threshold	+1.75		+2.5	V	Positive-going
Input Low Threshold	+0.75		+1.35	V	Negative-going
Input Impedance	3		7	k Ω	
TTL Output Level					
V_{OL}			0.4	V	$V_{CC} = +4.75V, I_{OUT} = +1.6mA$
V_{OH}	2.4			V	$V_{CC} = +4.75V, I_{OUT} = -0.5mA$
Maximum Receiving Rate	200			kbps	
RS-422 DRIVER					
TTL Input Level					
V_{IL}	0		0.8	V	
V_{IH}	2.0			V	
High Level Output	2.75		6.0	V	$I_{OH} = -20mA$
Low Level Output			1.0	V	$I_{OL} = +20mA$
Differential Output	± 2			V	$R_L = 100\Omega$
			± 6	V	$R_L = \infty$
Short Circuit Current			± 100	mA	Note 2
Output Current			± 500	μA	$-0.25V \leq V_o \leq 6V$; power off
Transition Time			400	ns	$R_L = 100\Omega, C_L = 15pF$; Note 3
Maximum Transmission Rate	1,000			kbps	
RS-422 RECEIVER					
Common Mode Range			± 7	V	Note 4
Differential Input			± 15	V	Note 4
Differential Input Threshold	-0.2		+0.2	V	$T_A = 25^\circ C$
Input Voltage Hysteresis	30			mV	$V_{CM} = 0V; T_A = 25^\circ C$
Input Resistance	3			k Ω	$-7V \leq V_{CM} \leq +7V$
TTL Output Level					
V_{OL}			0.4	V	$V_{CC} = +4.75V, I_{OUT} = +1.6mA$
V_{OH}	2.4			V	$V_{CC} = +4.75V, I_{OUT} = -0.5mA$
Maximum Receiving Rate	1,000			kbps	
Short Circuit Output Current			± 120	mA	$V_{OUT} = 0V$
POWER REQUIREMENTS					
$V_{DD} = +12V, \pm 10\%$		7	15	mA	Note 5
$V_{CC} = +5V, \pm 10\%$		5	7	mA	Note 5
$V_{EE} = -12V, \pm 10\%$		11	20	mA	Note 5
ENVIRONMENTAL					
Operating Temperature					
-CS	0		+70	$^\circ C$	
-MR	-55		+125	$^\circ C$	
Storage Temperature	-65		+150	$^\circ C$	

Notes:

1. In Loopback mode
 2. Only one output drive pin per package will be shorted at any time
 3. From 10% to 90% of steady-state
 4. This is an absolute maximum rating; normal operating levels are $V_{in} < 5V$
 5. Outputs unloaded; Inputs tied to GND; $T_c = +25^\circ C$; $V_L = 0V$; LB=0
- Typical **SP304** current drains under full load are:
18mA (+12V), 10mA (-12V) and 7mA (+5V) in RS-232 mode only;
5mA (+12V), 7mA (-12V) and 56mA (+5V) in RS-422 mode only;
12mA (+12V), 14mA (-12V) and 31mA (+5V) in RS-232 and RS-422 modes;
RS232 loads 3k Ω , 2500pF, 20kHz; RS422 outputs across 100 Ω , 500kHz.

TYPICAL PERFORMANCE CURVES

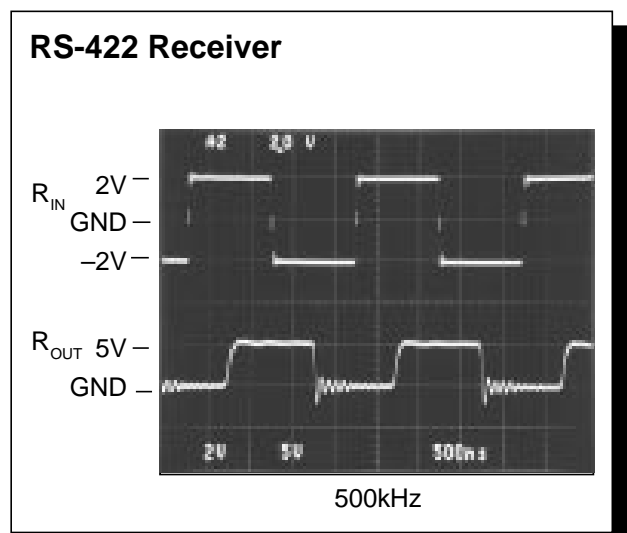
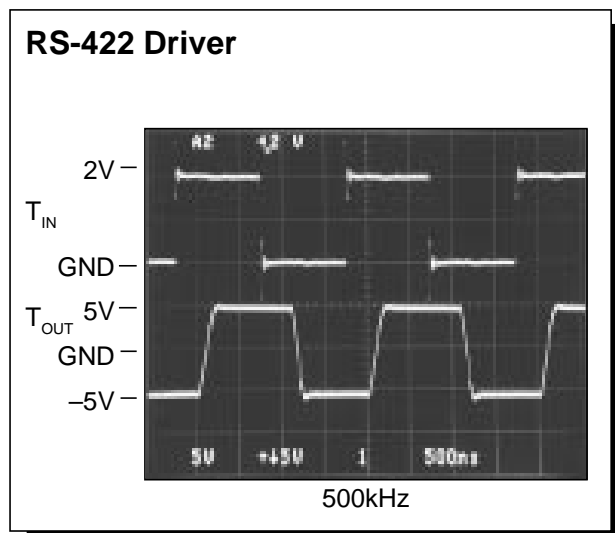
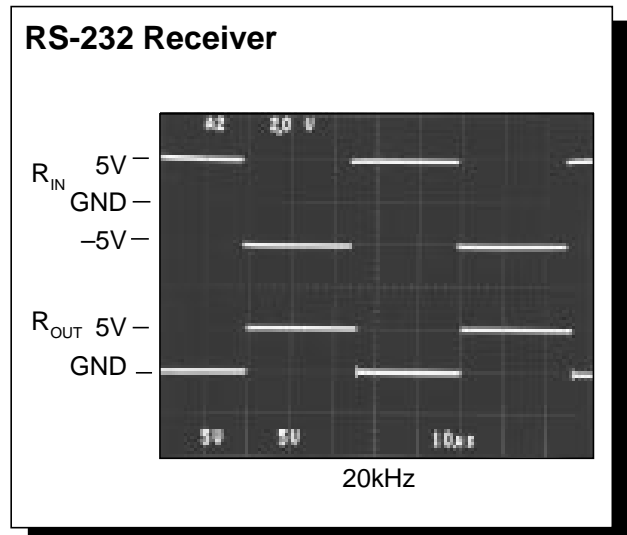
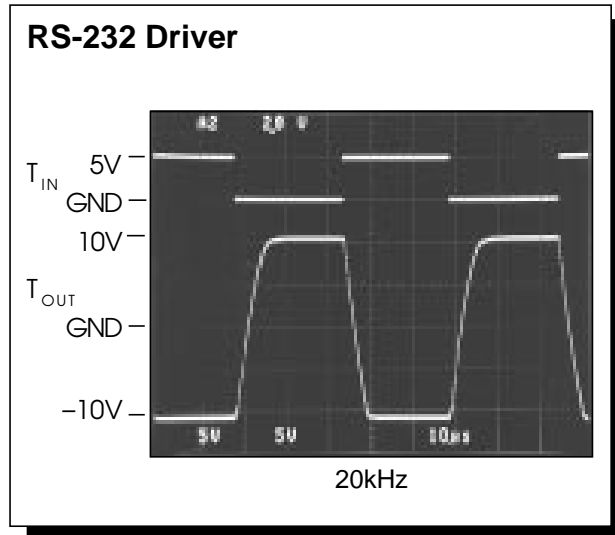

PIN ASSIGNMENTS

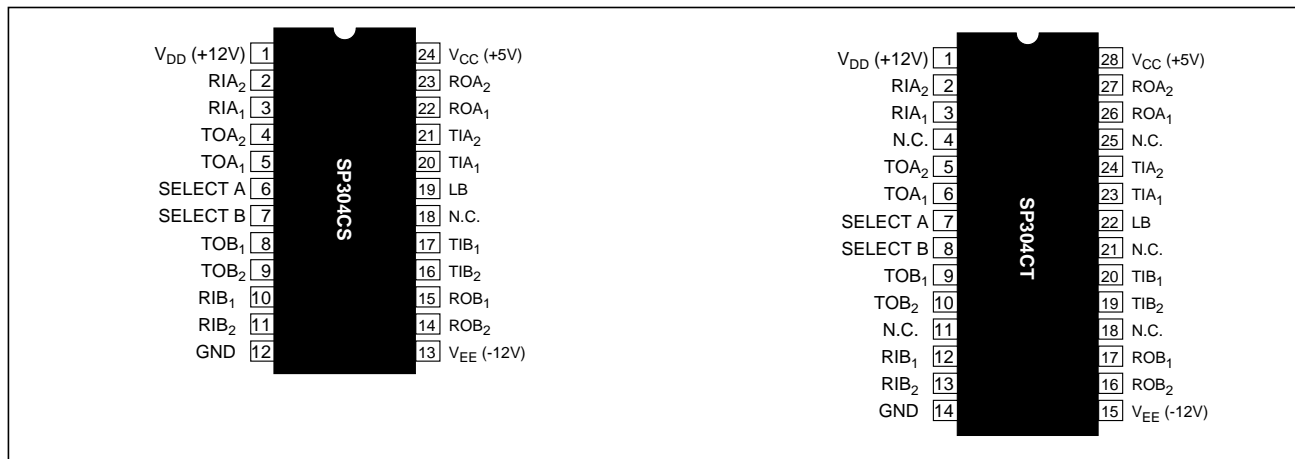

FEATURES...

The **SP304** is a proprietary single-chip device that contain both RS-232 and RS-422 protocol line drivers and receivers. It is pin-for-pin compatible with the **Sipex SP302**. Like the **SP302**, its configuration may be changed at any time by logic levels on two control lines. In any configuration, the **SP304** fully meets the requirements of both the EIA RS-232D and RS-422 data communication standards. The **SP304** enhancements include improved isolation from external signals and a true high-impedance driver output in the loopback test mode, and no power up sequence requirements.

The RS-232 line driver circuits convert TTL logic level inputs into inverted RS-232 output signals. The RS-422 line drivers convert TTL logic levels into RS-422 differential output signals. The RS-422 line driver outputs feature high source and sink current capability. All line drivers are internally protected against short circuits on their outputs.

The RS-232 receivers convert the EIA RS-232 input signals to inverted TTL output logic levels. The RS-422 receivers convert the EIA RS-422 differential input signals into non-inverted TTL output logic levels. Receiver input filtering provides excellent high frequency noise immunity. Input pulses with widths less than 1μs are completely ignored. The RS-232 receivers have the additional feature of voltage hysteresis, which helps eliminate spurious output transitions that

might result from low amplitude noise voltages during slower-speed signal transitions.

A loopback test mode is provided that puts the driver outputs to a high impedance tri-state level, and routes the driver outputs to their associated receiver inputs. In this configuration, the signal path is non-inverting from the TTL driver input to the receiver TTL output. This operating mode allows the controlling system to perform diagnostic self-test of the RS-232/RS-422 driver/receiver circuitry at speeds up to 3,000 bits per second. In the loopback mode a ±13.2V input range may be applied to the receiver inputs with no interference to the loopback test. In addition, the driver outputs are in a true high-impedance state during loopback.

The **SP304** is available in 24-pin single width (0.300") plastic DIP and 28-pin SOIC packages, for operation over the commercial and industrial temperature ranges.

USING THE SP304 POWER SUPPLIES

The **SP304** requires ±12V and +5V for full RS-232 and RS-422 operation. The ±12V supplies set up the RS-232 ±9V voltage swings, and the +5V is used for the internal logic that formats the communications mode and controls the loopback function. The supply voltages can be decreased to as low as ±7V for V_{DD} and V_{EE}, and

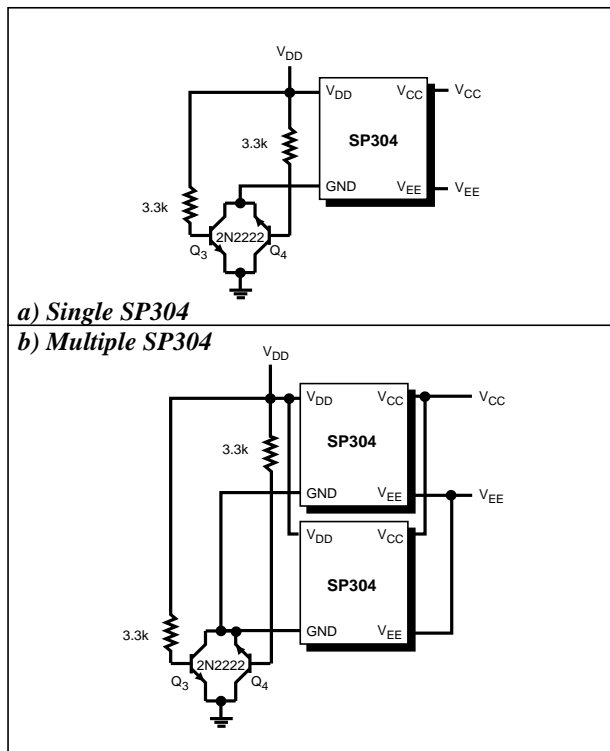

Figure 1. Isolating the SP304 from Ground.

+4.0V for V_{CC} . Under these supply conditions, derated performance can be expected.

POWER SUPPLY SEQUENCING

There are no special power-up sequencing requirements for the **SP304**.

GENERAL USAGE

RS-232 Operation

The **SP304** is a fully compliant RS-232 device. Its outputs are fully protected against shorts to $\pm 20V$ with no external circuitry. If the potential exists for momentary shorts to voltages greater than $\pm 20V$, it is recommended that a 220Ω resistor be wired in series with each driver output. This will limit any damage from the higher short-circuit current from these higher voltage potentials. Voltage clamps such as back-to-back Zener diodes can be used to clamp the driver outputs to “safe” levels. Short circuit current to ground is internally limited, and can therefore be sustained infinitely. Under normal operating conditions, the drivers can typically source 7mA at $\pm 5V$ output, which exceeds the minimum RS-232 standards requirement.

If an **SP304** transmitter output occupies a data

transmission line with other RS-232 devices which are not powered by the same power supplies, it is possible that a device that is not powered will have a low impedance path to ground at its driver output. The RS-232 standards require that with no power applied to the device, the impedance from a transmitter output to ground must be greater than 300Ω . This can be easily achieved as shown in *Figure 1a*, where an external transistor is used as a switch to isolate an **SP304** from ground in the power off condition. With V_{DD} turned on, the transistor switch is on, connecting ground (GND) for the device to the circuit ground. In a power-off condition, this transistor is switched off, thus isolating the unit from circuit ground, and thereby leaving the driver in a high impedance state. Multiple **SP304s** can be connected as shown in *Figure 1b*.

RS-422 OPERATION

The **SP304** is a fully compliant RS-422 device when operating in the RS-422 mode. Baud rate and drive capability have been balanced to provide as much versatility as possible. The **SP304** is both guaranteed for a 1Mbps data rate,

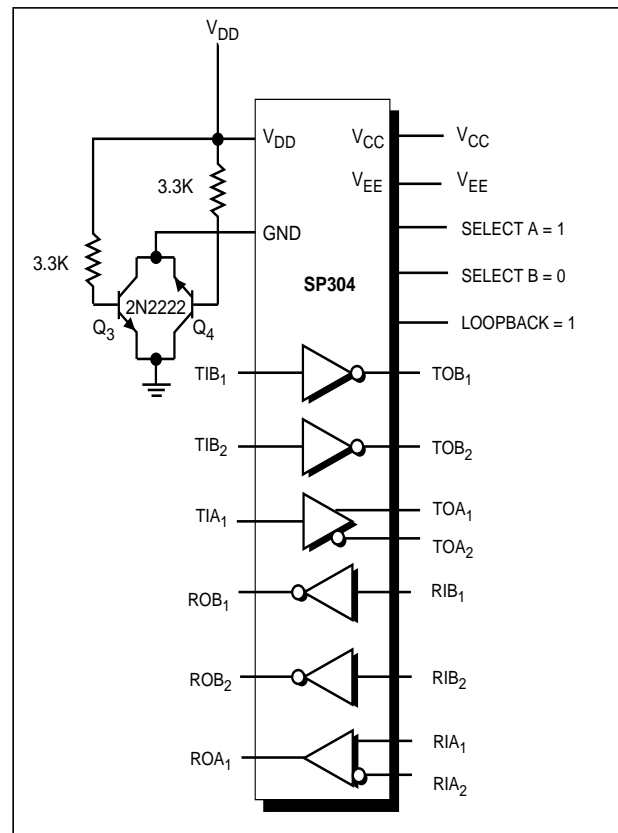

Figure 2. Typical Circuit

supplying $\pm 2\text{V}$ minimum into a 100Ω load. Short circuit protection for the RS-422 operating mode is the same as in the RS-232 mode. The driver outputs can be shorted to ground for an infinite duration, with a maximum current of $\pm 100\text{mA}$.

The RS-422 receivers accept differential signals at a 1Mbps rate, and translate them to a non-inverted TTL output. The receivers are specified with a $\pm 15\text{V}$ differential input voltage, which means that to operate normally, the difference between the voltages at the inputs cannot exceed $\pm 15\text{V}$. The common mode voltage is specified as $\pm 7\text{V}$. This identifies the midpoint of the range about which the differential input must lie so that the receiver can detect a change of state. Within this $\pm 7\text{V}$ range, the receivers will recognize a change in state with a $\pm 200\text{mV}$ differential threshold voltage. Since the RS-232 and RS-422 inputs are shared, all receiver inputs are protected to $\pm 30\text{V}$ to guard against inadvertently applying an RS-232 signal to an input that is configured for RS-422.

Figure 2 shows a typical circuit for the **SP304**. In this case the **SP304** is shown configured for one (1) duplex RS-422 and two (2) duplex RS-232 communication paths.

CONFIGURING THE SP304

Figures 3, 4 and 5 show the various combinations of simultaneous RS-232 and RS-422 operation that can be achieved with the **SP304**. Each of these configurations are software selectable by logic level on the SELECT A and SELECT B control lines. Configuration can be changed “on-the-fly”.

FIGURE 3: SP304 CONTROL LOGIC CONFIGURATION

SELECTION	LOGIC VALUE	LOGIC VALUE	LOGIC VALUE	LOGIC VALUE
SELECT A: SELECT B:	0 0	0 1	1 0	1 1
NON- LOOPBACK (LB = 1)				
LOOPBACK (LB=0)				

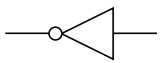
RS-232 DRIVER
* Tri-state Output

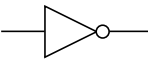
RS-232 RECEIVER

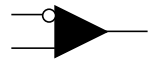

RS-422 RECEIVER

RS-422 DRIVER

FIGURE 4: SP304 CONFIGURATIONS

Four-Channel Duplex RS-232

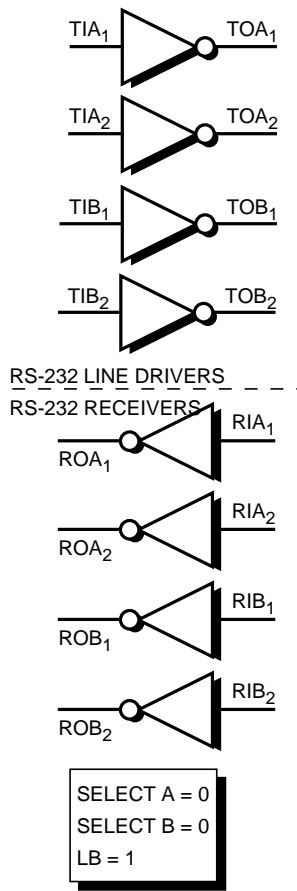
Four independent channels of RS-232 line driver and four channels of RS-232 receiver.



Two-Channel Duplex RS-232 & One-Channel Duplex RS-422

Two RS-232 line drivers and receivers, and a single RS-422 line driver and receiver.

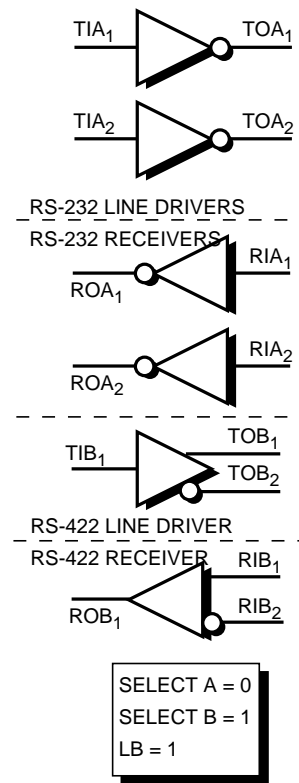

FIGURE 5: SP304 CONFIGURATIONS

Two-Channel Duplex RS-232 & One-Channel Duplex RS-422 Opposite Drivers

Two RS-232 line drivers and receivers, and a single RS-422 line driver and receiver. At first glance, this is the same configuration as that in *Figure 4*. Note however that functions are activated on the opposite channels.

Two-Channel Duplex RS-422

Two RS-422 line drivers and two RS-422 receivers.

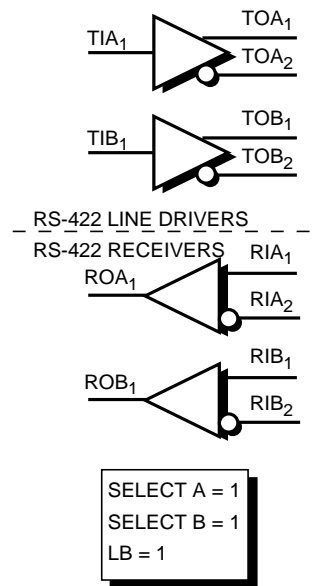
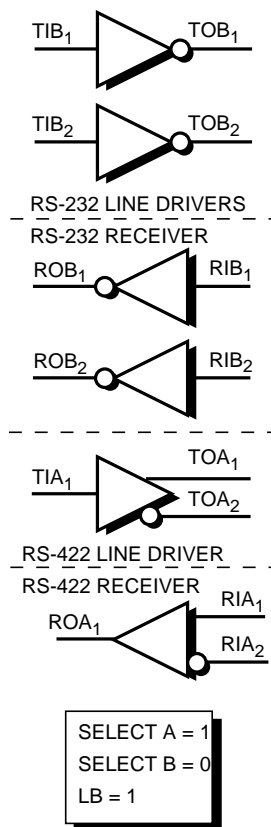

LOOPBACK

The **SP304** has a function called loopback, which is essentially a chip self-test. However, by connecting system test loops with the inputs and outputs of the **SP304**, a system-level diagnostic can be run on power-up or on command. The test loops can be

enabled and disabled allowing both system test and operation with the same components. A maximum data rate for loopback of 3kbps is recommended. Loopback is a pin-programmable function, activated by a logic low on the **LB** pin (19). As shown in these figures, the loopback function internally con-

SP304 CONFIGURATIONS IN LOOPBACK MODE

Two -Channel Full Duplex RS-232

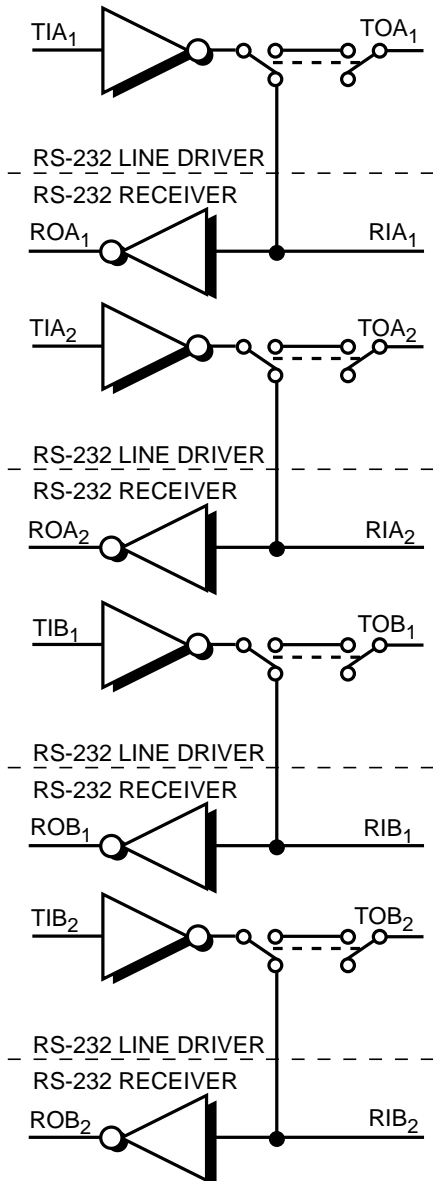

SELECT A = 0
SELECT B = 0
LB = 0 (ACTIVE)

One-Channel Full Duplex RS-232 & One-Channel Full Duplex RS-422

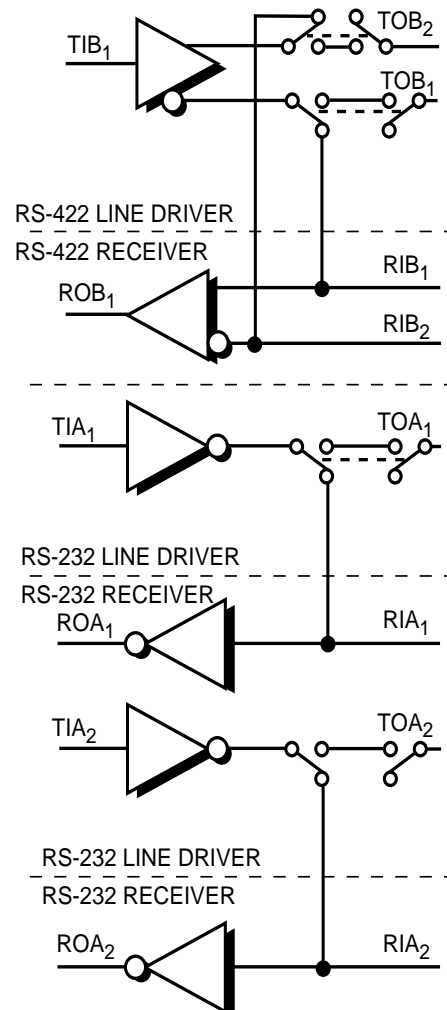

SELECT A = 0
SELECT B = 1
LB = 0 (ACTIVE)

nects the driver outputs to the corresponding receiver inputs, and switches the output pin to a high impedance from V_{EE} to ground. Receiver outputs are left active for signal verification.

During loopback, the receiver inputs are tied to ground via a 5kΩ pull-down resistor. The receiver inputs can accept the full ±15V swings with no interference to the loopback function.

SP304 CONFIGURATIONS IN LOOPBACK MODE

One-Channel Full Duplex RS-232 & One-Channel Full Duplex RS-422 Opposite Drivers

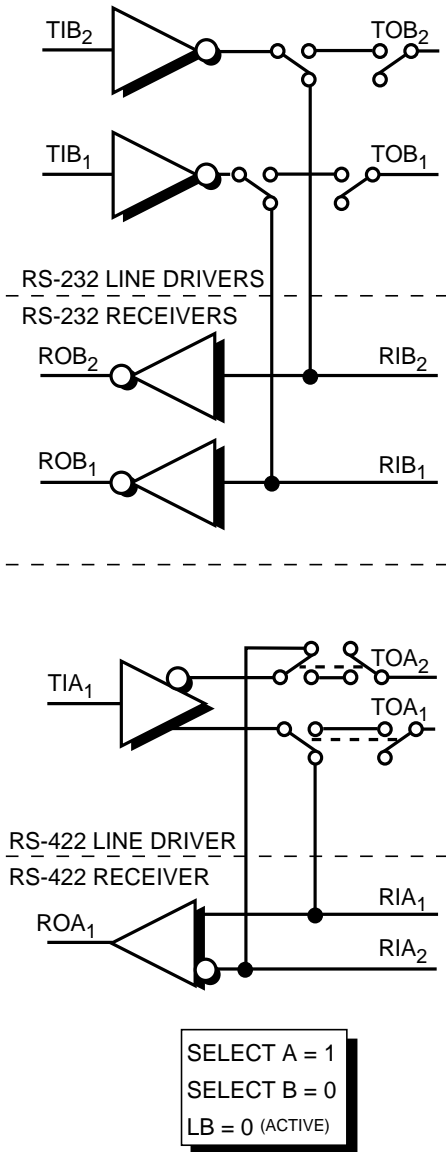

Two-Channel Full Duplex RS-422

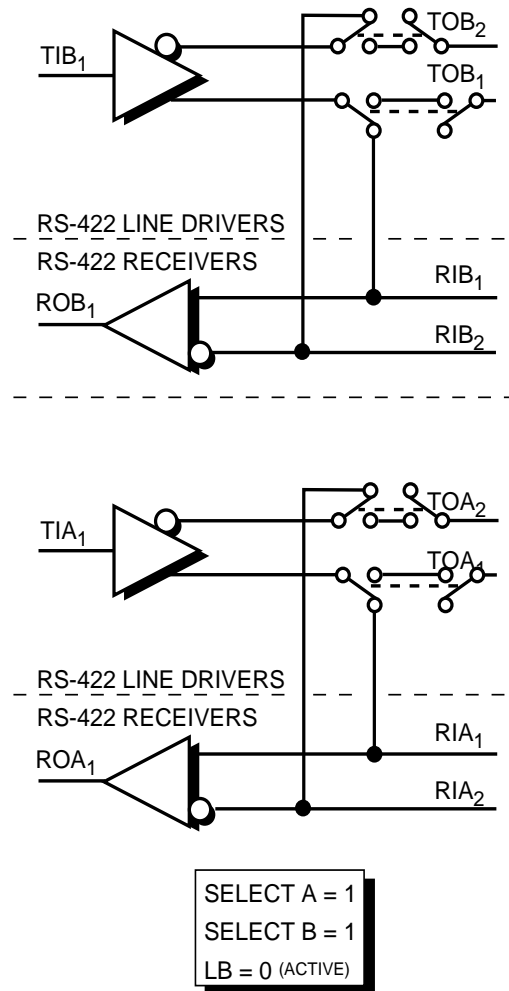

ORDERING INFORMATION

Model	Max # of Duplex Channels		Temperature	Package
	RS-232	RS-422		
SP304CS	4	2	0°C to 70°C	24-pin Single-Width Plastic DIP
SP304CT	4	2	0°C to 70°C	28-pin SOIC
SP304ES	4	2	-40°C to 85°C	24-pin Single-Width Plastic DIP
SP304ET	4	2	-40°C to 85°C	28-pin SOIC