

## 3V RS-232 Serial Transceiver with Logic Selector

- 3 Driver/ 2 Receiver Architecture
- Logic selector function ( $V_L$ ) sets TTL input/output levels for mixed logic systems
- Meets true EIA/TIA-232-F Standards from a +3.0V to +5.5V power supply
- Interoperable with EIA/TIA-232 and adheres to EIA/TIA-562 down to a +2.7V power source
- Minimum 250Kbps data rate under load
- Regulated Charge Pump Yields Stable RS-232 Outputs Regardless of  $V_{CC}$  Variations
- ESD Specifications:
  - ±2kV Human Body Model
- Applications
  - Palmtops
  - Cell phone Data Cables
  - PDA's



### DESCRIPTION

The SP3203 provides a RS-232 transceiver solution for portable and hand-held applications such as palmtops, PDA's and cell phones. The SP3203 uses an internal high-efficiency, charge-pump that requires only 0.1 $\mu$ F capacitors during 3.3V operation. This charge pump and Sipex's driver architecture allow the SP3203 to deliver compliant RS-232 performance from a single power supply ranging from +3.0V to +5.5V.

The SP3203 is a 3-driver/2-receiver device, with a unique  $V_L$  pin to program the TTL input and output logic levels to allow interoperation in mixed-logic voltage systems such as PDA's and cell phones. Receiver outputs will not exceed  $V_L$  for  $V_{OH}$  and transmitter input logic levels are scaled by the magnitude of the  $V_L$  input.

## ABSOLUTE MAXIMUM RATINGS

These are stress ratings only and functional operation of the device at these ratings or any other above those indicated in the operation sections of the specifications below is not implied. Exposure to absolute maximum rating conditions for extended periods of time may affect reliability and cause permanent damage to the device.

$V_{CC}$ .....	-0.3V to +6.0V
$V_+$ (NOTE 1).....	-0.3V to +7.0V
$V_-$ (NOTE 1).....	+0.3V to -7.0V
$V_+ +  V_- $ (NOTE 1).....	+13V
$I_{CC}$ (DC $V_{CC}$ or current).....	$\pm 100$ mA

**Input Voltages**

TxIN, SHUTDOWN = GND.....	-0.3V to +6.0V
RxIN.....	+25V

## Output Voltages

TxOUT.....	$\pm 13.2$ V
RxOUT.....	-0.3V to ( $V_L + 0.3$ V)

## Short-Circuit Duration

TxOUT.....	Continuous
Storage Temperature.....	-65°C to +150°C
Power Dissipation per Packages	
20-Pin TSSOP	
(derate 7.0mW/°C above +70°C).....	560mW

**NOTE 1:**  $V_+$  and  $V_-$  can have maximum magnitudes of 7V, but their absolute difference cannot exceed 13V.

## SPECIFICATIONS

( $V_{CC} = V_L = +3$ V to +5.5V, C1-C4 = 0.1 $\mu$ F, tested at +3.3V  $\pm 10\%$ , C1 = 0.047 $\mu$ F, C2-C4 = 0.33 $\mu$ F, tested at +5.0V  $\pm 10\%$ ,  $T_A = T_{MIN}$  to  $T_{MAX}$ , unless otherwise noted. Typical values are at  $V_{CC} = V_L = +3.3$ V,  $T_A = +25^\circ$ C.)

PARAMETER	MIN.	TYP.	MAX.	UNITS	CONDITIONS	
<b>DC CHARACTERISTICS</b> ( $V_{CC} = +3.3$ V or +5V, $T_A = +25^\circ$ C)						
Supply Current		0.3	1	mA	Shutdown = $V_{CC}$ , no load	
Shutdown Supply Current		1	10	$\mu$ A	Shutdown = GND	
<b>LOGIC INPUTS</b>						
Input Logic Threshold Low			0.8	V	TxIN, Shutdown	$V_L = 3.3$ V or 5.0V
			0.6			$V_L = 2.5$ V
Input Logic Threshold High	2.4			V	TxIN, Shutdown	$V_L = 5.0$ V
	2.0					$V_L = 3.3$ V
	1.4					$V_L = 2.5$ V
		0.9				$V_L = 1.8$ V
Transmitter Input Hysteresis		0.5		V		
Input Leakage Current		$\pm 0.01$	$\pm 1$	$\mu$ A	TxIN, Shutdown	
<b>RECEIVER OUTPUTS</b>						
Output Leakage Currents		$\pm 0.05$	$\pm 10$	$\mu$ A	RxOUT, receivers disabled	
Output Voltage Low			0.4	V	$I_{OUT} = 1.6$ mA	
Output Voltage High	$V_L - 0.6$	$V_L - 0.1$		V	$I_{OUT} = -1$ mA	

## SPECIFICATIONS (continued)

( $V_{CC} = V_L = +3V$  to  $+5.5V$ ,  $C1-C4 = 0.1\mu F$ , tested at  $+3.3V \pm 10\%$ ,  $C1 = 0.047\mu F$ ,  $C2-C4 = 0.33\mu F$ , tested at  $+5.0V \pm 10\%$ ,  $T_A = T_{MIN}$  to  $T_{MAX}$ , unless otherwise noted. Typical values are at  $V_{CC} = V_L + 3.3V$ ,  $T_A = +25^\circ C$ .)

PARAMETER	MIN.	TYP.	MAX.	UNITS	CONDITIONS	
<b>RECEIVER INPUTS</b>						
Input Voltage Range	-25		+25	V		
Input Threshold Low	0.8	1.5		V	$T_A = +25^\circ C$	$V_L = 5.0V$
	0.6	1.2				$V_L = 2.5V$ or $3.3V$
Input Threshold High		1.8	2.4	V	$T_A = +25^\circ C$	$V_L = 5.0V$
		1.5	2.4			$V_L = 2.5V$ or $3.3V$
Input Hysteresis		0.5		V		
Input Resistance	3	5	7	k $\Omega$	$T_A = +25^\circ C$	
<b>TRANSMITTER OUTPUTS</b>						
Output Voltage Swing	$\pm 5$	$\pm 5.4$		V	All transmitter outputs loaded with $3k\Omega$ to $T_A = 25^\circ C$	
Output Resistance	300	10M		$\Omega$	$V_{CC} = V_+ = V_- = 0$ , transmitter output = $\pm 2V$	
Output Short-Circuit Current			$\pm 60$	mA	$V_{TXOUT} = 0$	
Output Leakage Current			$\pm 25$	$\mu A$	$V_{TXOUT} = \pm 12$ , transmitter disabled; $V_{CC} = 0$ or $3.0V$ to $5.5V$	

PARAMETER	MIN.	TYP.	MAX.	UNITS	CONDITIONS
Maximum Data Rate	250			kbps	$R_L = 3k\Omega$ , $C_L = 1000pF$ , one transmitter switching
Receiver Propagation Delay	$t_{PHL}$	0.15		$\mu s$	Receiver input to receiver output $C_L = 150pF$
	$t_{PLH}$	0.15			
Receiver Output Enable Time		200		ns	normal operation
Receiver Output Disable Time		200		ns	normal operation
Time to Exit Shutdown		100		$\mu s$	$ V_{TXOUT}  > 3.7V$
Transmitter Skew $ t_{PHL} - t_{PLH} $		100		ns	(Note 2)
Receiver Skew $ t_{PHL} - t_{PLH} $		50		ns	
Transition-Region Slew Rate	6		30	V/ $\mu s$	$V_{CC} = 3.3V$ $T_A = +25^\circ C$ $R_L = 3k\Omega$ to $7k\Omega$ , measured from $+3V$ to $-3V$ or $-3V$ to $+3V$
	4		30		

**Note 2.** Transmitter skew is measured at the transmitter zero crosspoint.

NAME	FUNCTION	PIN NUMBER
		SP3203
C1+	Positive terminal of the symmetrical charge-pump capacitor, C1.	1
V+	Regulated +5.5V output generated by the charge pump.	2
C1-	Negative terminal of the symmetrical charge-pump capacitor, C1.	3
C2+	Positive terminal of the symmetrical charge-pump capacitor, C2.	4
C2-	Negative terminal of the symmetrical charge-pump capacitor, C2.	5
V-	Regulated -5.5V output generated by the charge pump.	6
R <sub>1</sub> IN	RS-232 receiver input.	14
R <sub>2</sub> IN	RS-232 receiver input.	13
R <sub>1</sub> OUT	TTL/CMOS receiver output.	11
R <sub>2</sub> OUT	TTL/CMOS receiver output.	10
T <sub>1</sub> IN	TTL/CMOS driver input.	7
T <sub>2</sub> IN	TTL/CMOS driver input.	8
T <sub>3</sub> IN	TTL/CMOS driver input.	9
T <sub>1</sub> OUT	RS-232 driver output.	17
T <sub>2</sub> OUT	RS-232 driver output.	16
T <sub>3</sub> OUT	RS-232 driver output.	15
GND	Ground.	18
V <sub>CC</sub>	+3.0V to +5.5V supply voltage.	19
$\overline{\text{SHUTDOWN}}$	Apply logic LOW to shut down drivers and charge pump.	20
V <sub>L</sub>	Logic-Level Supply Voltage Selection	12

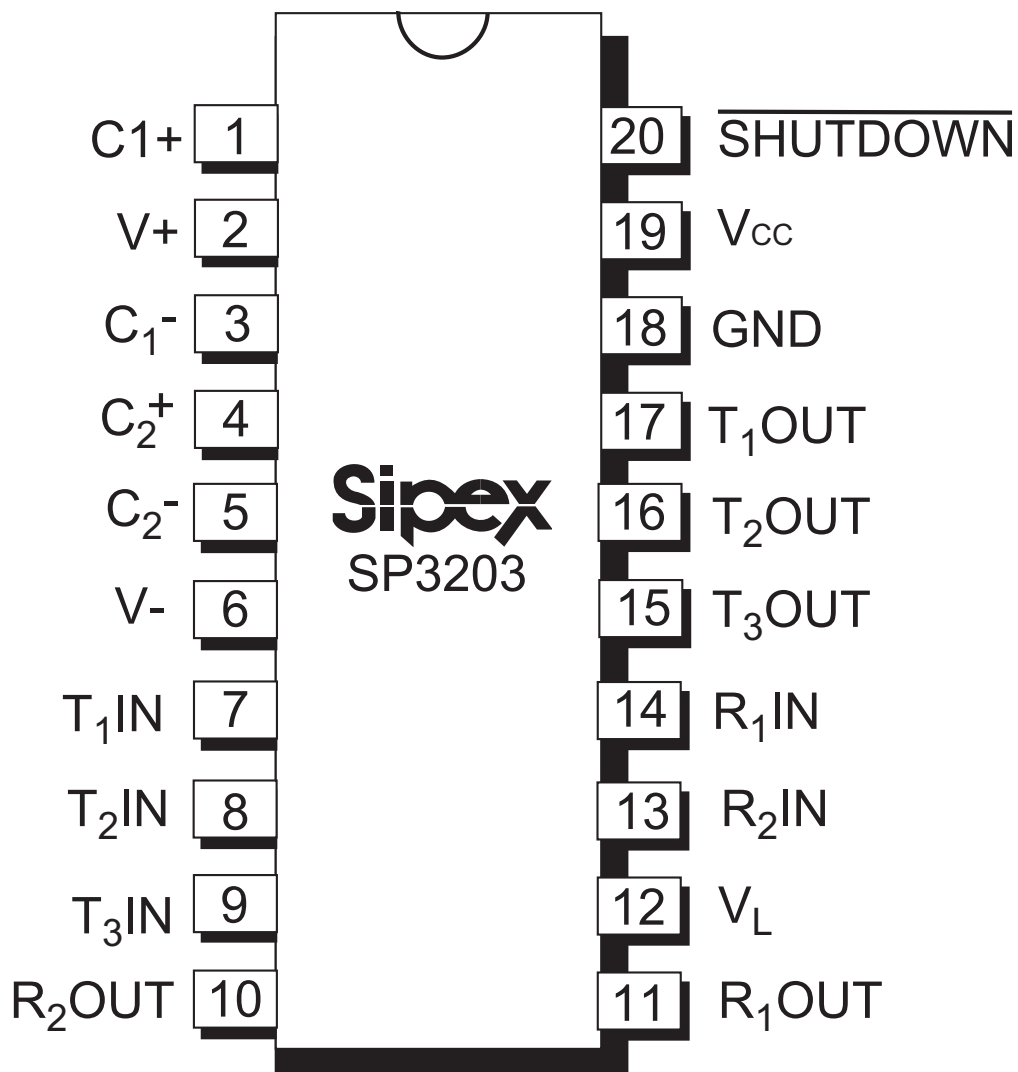

Figure 7. SP3203 Pinout Configuration

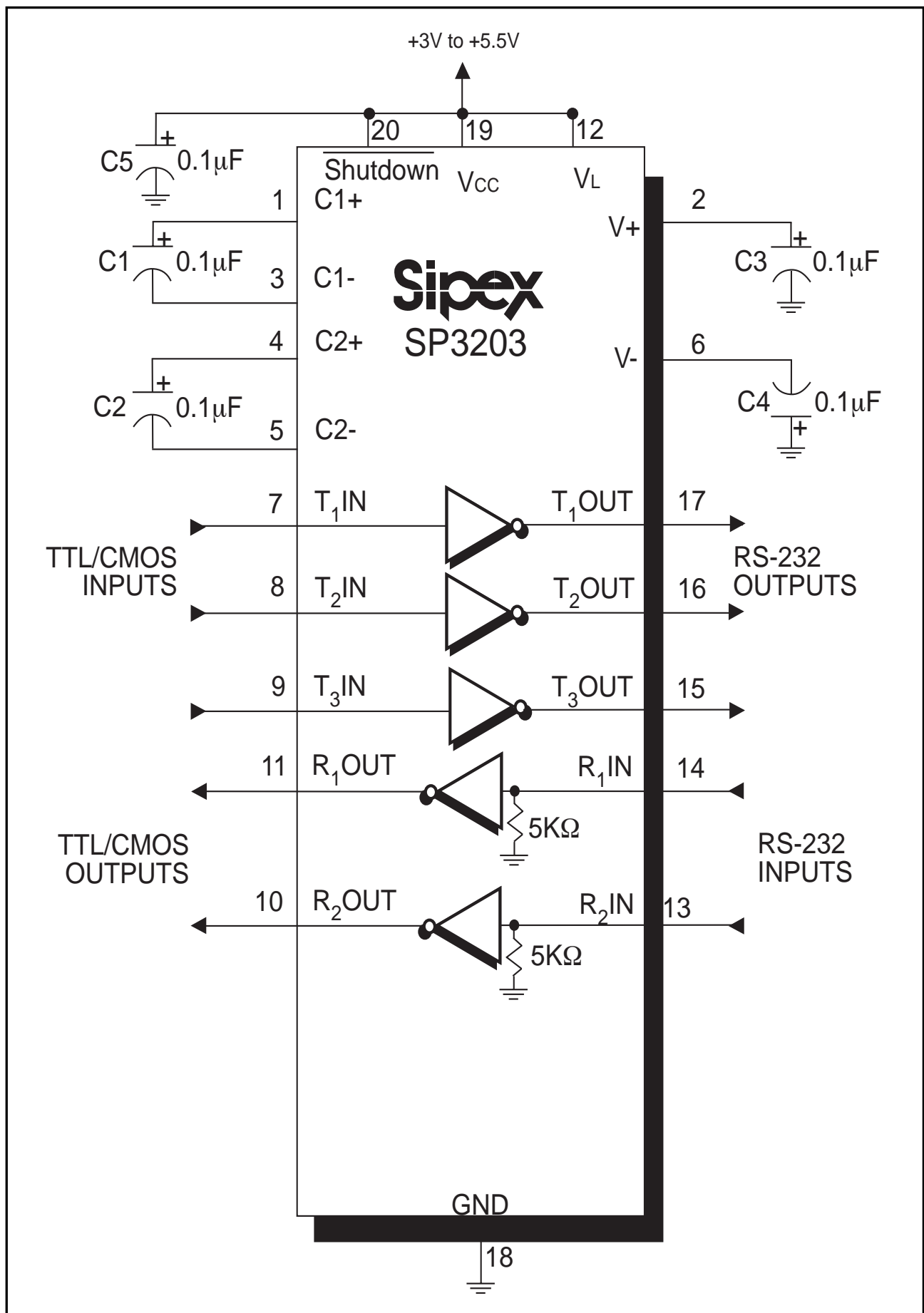

Figure 8. SP3203 Typical Operating Circuit

## DESCRIPTION

The SP3203 is a 3-driver/2-receiver device that can be operated as a full duplex, RS-232 serial transceiver with the 3rd driver acting as a control line allowing a Ring Indicator (RI) signal to alert the UART on the PC.

This transceiver meet the EIA/TIA-232 and ITU-T V.28/V.24 communication protocols and can be implemented in battery-powered, portable, or hand-held applications such as notebook or palmtop computers, PDA's and cell phones. The SP3203 devices feature Sipex's proprietary and patented (U.S.#5,306,954) on-board charge pump circuitry that generates  $\pm 5.5V$  RS-232 voltage levels from a single +3.0V to +5.5V power supply. The SP3203 devices can operate at a minimum data range of 250kbps, driving a single driver. The SP3203 is a 3-driver/2-receiver device.

## THEORY OF OPERATION

The SP3203 contains four basic circuit blocks: 1. drivers, 2. receivers, 3. a Sipex proprietary charge pump and 4.  $V_L$  circuitry.

### Drivers

The drivers are inverting level transmitters that convert TTL or CMOS logic levels to 5.0V EIA/TIA-232 levels with an inverted sense relative to the input logic levels. Typically, the RS-232 output voltage swing is  $\pm 5.4V$  with no load and  $\pm 5V$  minimum fully loaded. The driver outputs are protected against infinite short-circuits to ground without degradation in reliability. These drivers comply with the EIA-TIA-232F and all previous RS-232 versions. The driver output stages are turned off (High Impedance) when the device is in shutdown mode.

The drivers typically can operate at a data rate of 250Kbps. The drivers can guarantee a data rate of 120Kbps fully loaded with  $3K\Omega$  in parallel with 1000pF, ensuring compatibility with PC-to-PC communication software.

The slew rate of the driver output is internally limited to a maximum of  $30V/\mu s$  in order to meet the EIA standards (EIA RS-232D 2.1.7, Paragraph 5). The transition of the loaded output from HIGH to LOW also meets the monotonicity requirements of the standard.

The SP3203 driver can maintain high data rates up to 250Kbps with a single driver loaded. Figure 9 shows a loopback test circuit used to test the RS-232 Drivers. Figure 10 shows the test results of the loopback circuit with all three drivers active at 120Kbps with typical RS-232 loads in parallel with 1000pF capacitors. Figure 11 shows the test results where one driver was active at 250Kbps and all three drivers loaded with an RS-232 receiver in parallel with a 1000pF capacitor. The transmitter inputs do not have pull-up resistors. Connect unused inputs to ground or  $V_L$ .

### Receivers

The receivers convert  $\pm 5.0V$  EIA/TIA-232 levels to TTL or CMOS logic output levels. Receivers are disabled when in shutdown. The truth table logic of the SP3203 driver and receiver outputs can be found in Table 1.

Since receiver input is usually from a transmission line where long cable lengths and system interference can degrade the signal, the inputs have a typical hysteresis margin of 500mV. This ensures that the receiver is immune to noisy transmission lines. Should an input be left unconnected, an internal  $5K\Omega$  pulldown resistor to ground will commit the output of the receiver to a HIGH state.

### Charge Pump

The charge pump is a Sipex-patented design (U.S. #5,306,954) and uses a unique approach compared to older less-efficient designs. The charge pump still requires four external capacitors, but uses a four-phase voltage shifting technique to attain symmetrical 5.5V power supplies. The internal power supply

DEVICE: SP3203			
SHUTDOWN	T <sub>X</sub> OUT	R <sub>X</sub> OUT	Charge Pump
0	High-Z	High-Z	Inactive
1	Active	Active	Active

Table 1. SHUTDOWN Truth Table.

(Note: When device in shutdown, the SP3203's charge pump is turned off and V<sub>+</sub> decays to V<sub>CC</sub>. V<sub>-</sub> is pulled to ground and the transmitter outputs are disabled as High Impedance).

consists of a regulated dual charge pump that provides output voltages of 5.5V regardless of the input voltage (V<sub>CC</sub>) over the +3.0V to +5.5V range. This is important to maintain compliant RS-232 levels regardless of power supply fluctuations.

The charge pump operates in a discontinuous mode using an internal oscillator. If the output voltages are less than a of 5.5V, the charge pump is enabled. If the output voltages exceed a of 5.5V, the charge pump is disabled. This oscillator controls the four phases of the voltage shifting (Figure 12). A description of each phase follows.

### V<sub>SS</sub> Charge Storage-Phase 1 (Figure 13)

During this phase of the clock cycle, the positive side of capacitors C<sub>1</sub> and C<sub>2</sub> are initially charged to V<sub>CC</sub>. C<sub>1</sub><sup>+</sup> is then switched to GND and the charge in C<sub>1</sub><sup>-</sup> is transferred to C<sub>2</sub><sup>-</sup>. Since C<sub>2</sub><sup>+</sup> is connected to V<sub>CC</sub>, the voltage potential across capacitor C<sub>2</sub> is now 2 times V<sub>CC</sub>.

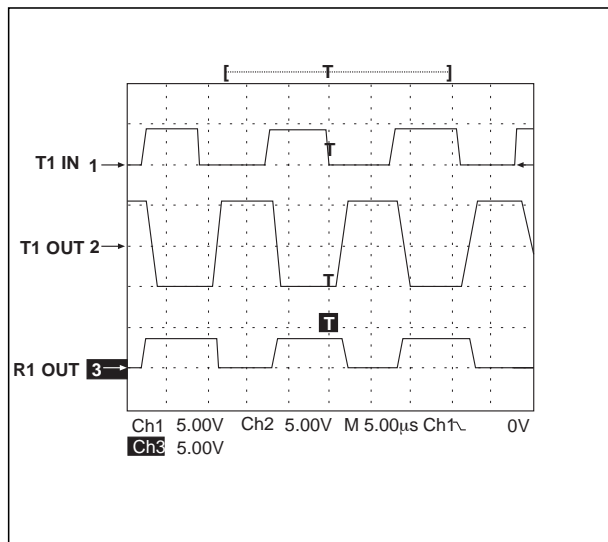

Figure 10. Loopback Test Circuit Result at 120Kbps (All Drivers Fully Loaded)

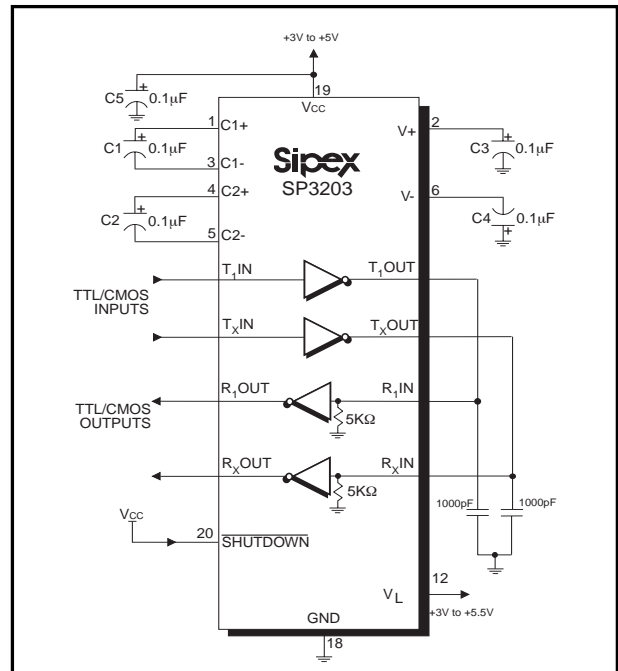

Figure 9. Loopback Test Circuit for RS-232 Driver Data Transmission Rates

### V<sub>SS</sub> Transfer-Phase 2 (Figure 14)

Phase two of the clock connects the negative terminal of C<sub>2</sub> to the V<sub>SS</sub> storage capacitor and the positive terminal of C<sub>2</sub> to GND. This transfers a negative generated voltage to C<sub>3</sub>. This generated voltage is regulated to a minimum voltage of -5.5V. Simultaneous with the transfer of the voltage to C<sub>3</sub>, the positive side of capacitor C<sub>1</sub> is switched to V<sub>CC</sub> and the negative side is connected to GND.

### V<sub>DD</sub> Charge Storage-Phase 3 (Figure 15)

The third phase of the clock is identical to the first phase — the charge transferred in C<sub>1</sub> pro-

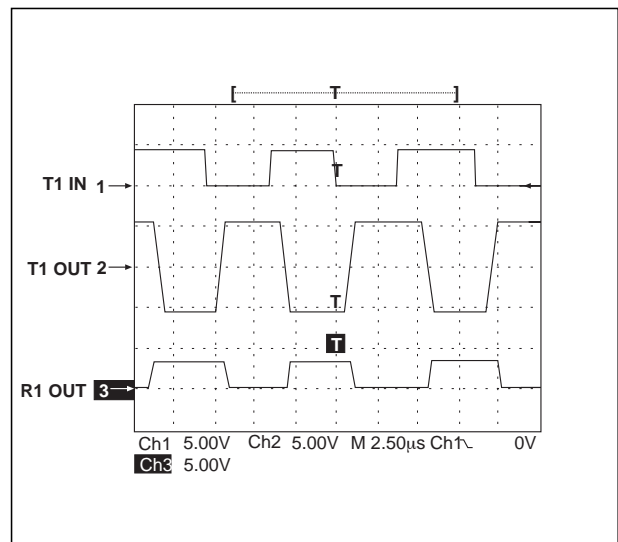

Figure 11. Loopback Test Circuit result at 250Kbps (All Drivers Fully Loaded)



duces  $-V_{CC}$  in the negative terminal of  $C_1$ , which is applied to the negative side of capacitor  $C_2$ . Since  $C_2^+$  is at  $V_{CC}$ , the voltage potential across  $C_2$  is 2 times  $V_{CC}$ .

#### **$V_{DD}$ Transfer-Phase 4 (Figure 16)**

The fourth phase of the clock connects the negative terminal of  $C_2$  to GND, and transfers this positive generated voltage across  $C_2$  to  $C_4$ , the  $V_{DD}$  storage capacitor. This voltage is regulated to +5.5V. At this voltage, the internal oscillator is disabled. Simultaneous with the transfer of the voltage to  $C_4$ , positive side of capacitor  $C_1$  is switched to  $V_{CC}$  and the negative side is connected to GND, allowing the charge pump cycle to begin again. The charge pump cycle will continue as long as the operational conditions for the internal oscillator are present.

Since both  $V^+$  and  $V^-$  are separately generated from  $V_{CC}$ , in a no-load condition,  $V^+$  and  $V^-$  will be symmetrical. Older charge pump approaches that generate  $V^-$  from  $V^+$  will show a decrease in the magnitude of  $V^-$  compared to  $V^+$  due to the inherent inefficiencies in the design.

The clock rate for the charge pump is typically operates at 250kHz. The external capacitors are usually 0.1 $\mu$ F with a 16V breakdown voltage rating.

#### **$V_L$ Supply Level**

Current RS-232 serial transceivers are designed with fixed 5V or 3.3V TTL input/output voltages levels. The  $V_L$  function in the SP3203 allows the end user to set the TTL input/output voltage levels independent of  $V_{CC}$ . By connecting  $V_L$  to the main logic bus of system, the TTL input/output limits and threshold are reset to interface with the on board low voltage logic circuitry.

<b>Capacitor Selection Table:</b>		
$V_{CC}$ (V)	C1 ( $\mu$ F)	C2-C4( $\mu$ F)
3.0 to 3.6	0.1	0.1
4.5 to 5.5	0.047	0.33
3.0 to 5.5	0.22	1

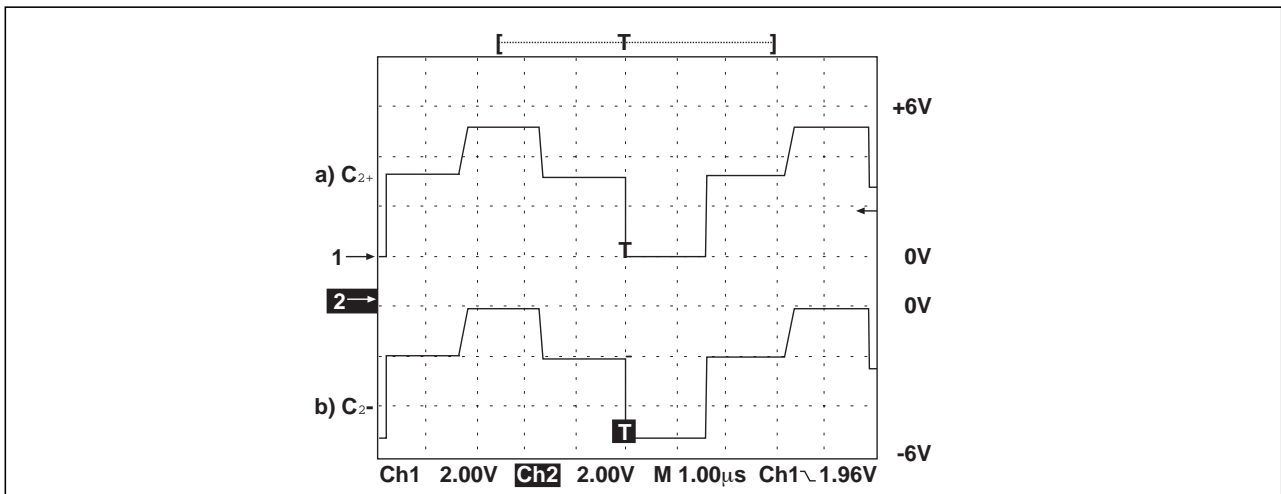

Figure 12. Charge Pump Waveforms

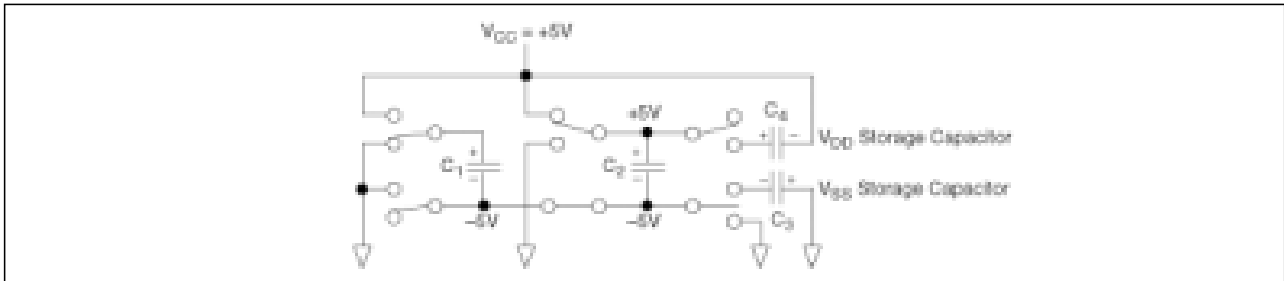

Figure 13. Charge Pump — Phase 4 -  $V_{SS}$  Charge Storage

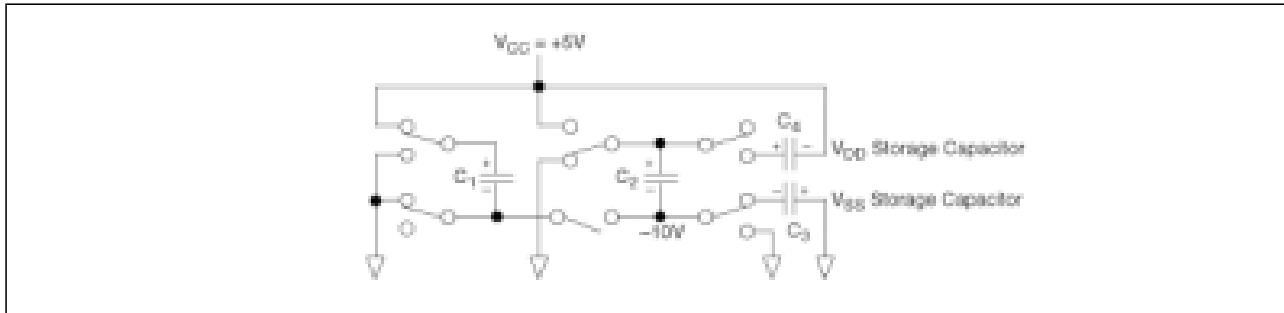

Figure 14. Charge Pump — Phase 3 -  $V_{SS}$  Charge Transfer

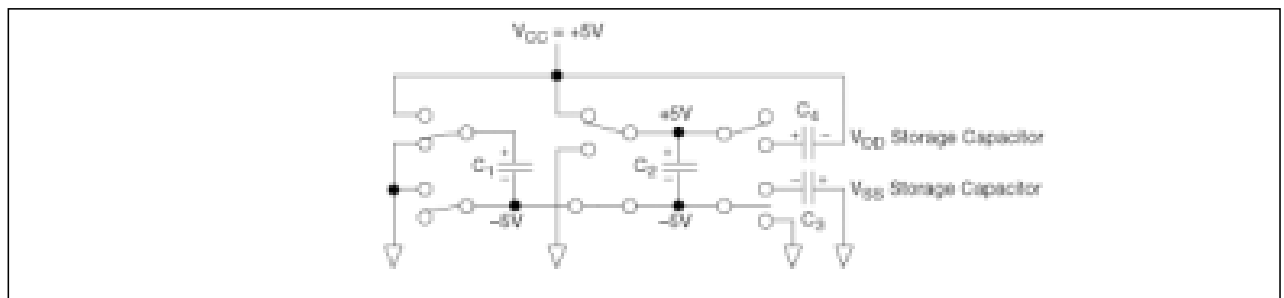

Figure 15. Charge Pump — Phase 2 -  $V_{DD}$  Charge Storage

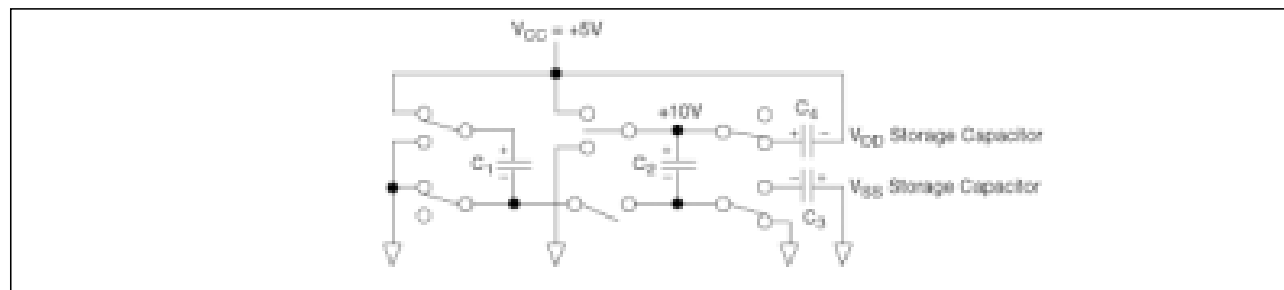

Figure 16. Charge Pump — Phase 1 -  $V_{DD}$  Charge Transfer

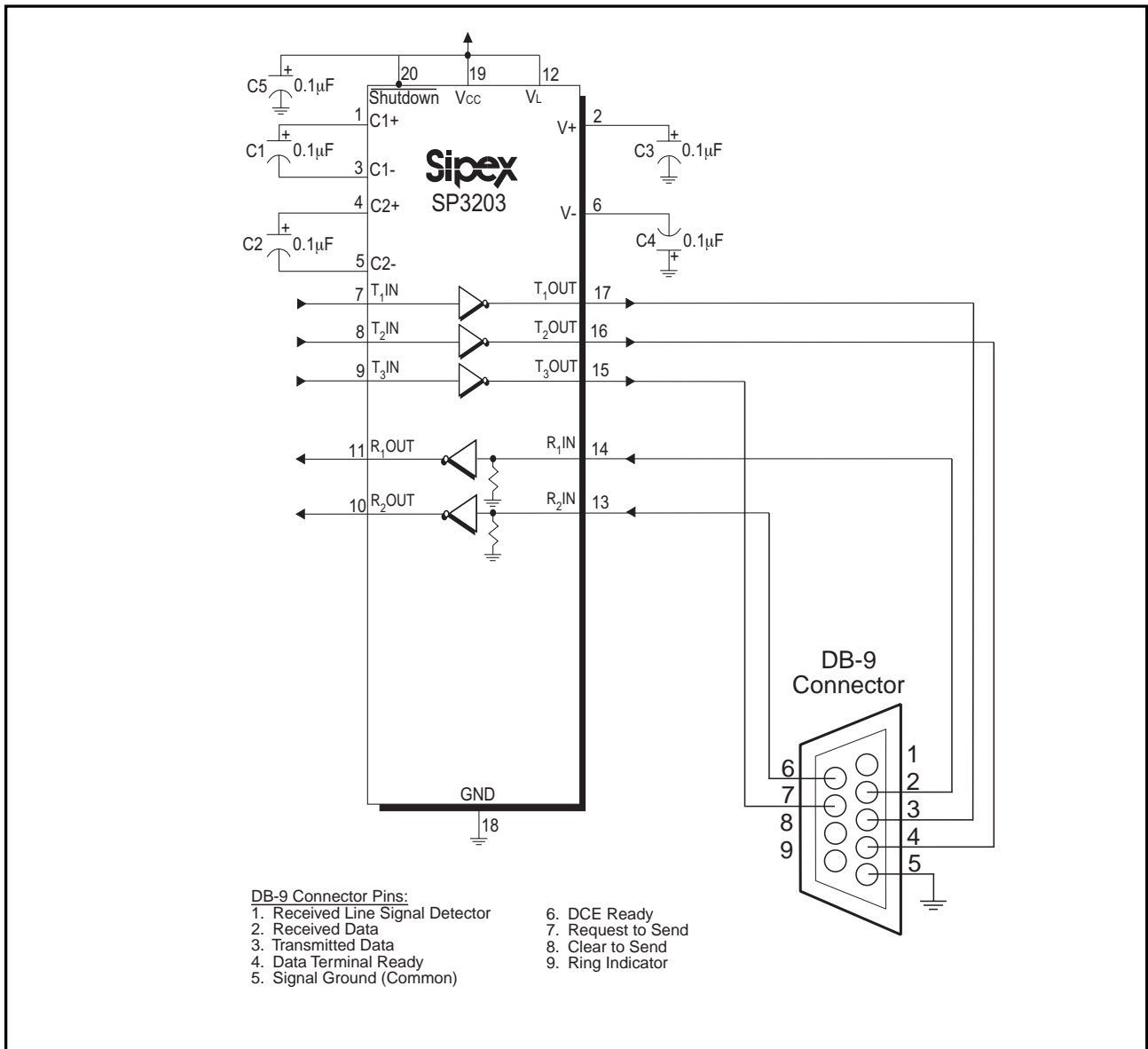

Figure 17. Circuit for the connectivity of the SP3203 with a DB-9 connector

## ESD TOLERANCE

The SP3203 incorporates ruggedized ESD cells on all driver output and receiver input pins.

The Human Body Model has been the generally accepted ESD testing method for semiconductors. This method is also specified in MIL-STD-883, Method 3015.7 for ESD testing. The premise of this ESD test is to simulate the human body's potential to store electro-static energy and

discharge it to an integrated circuit. The simulation is performed by using a test model as shown in Figure 18. This method will test the IC's capability to withstand an ESD transient during normal handling such as in manufacturing areas where the ICs tend to be handled frequently. For the Human Body Model, the current limiting resistor ( $R_s$ ) and the source capacitor ( $C_s$ ) are  $15k\Omega$  and  $100pF$ , respectively.

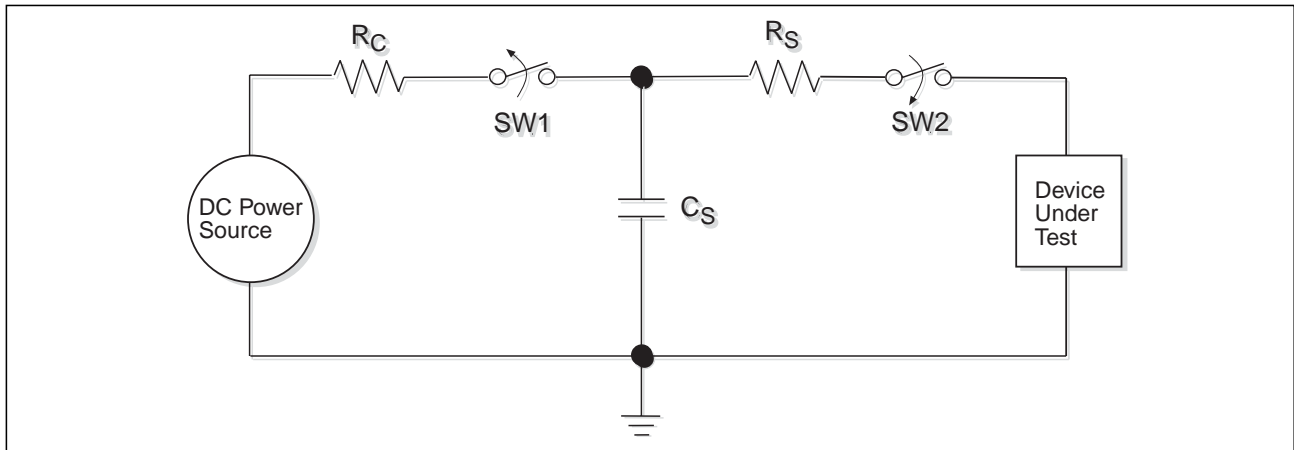
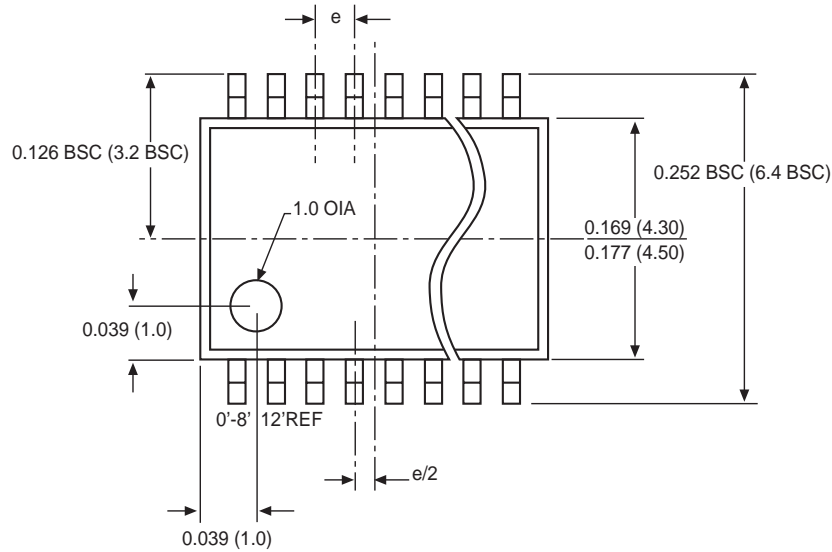
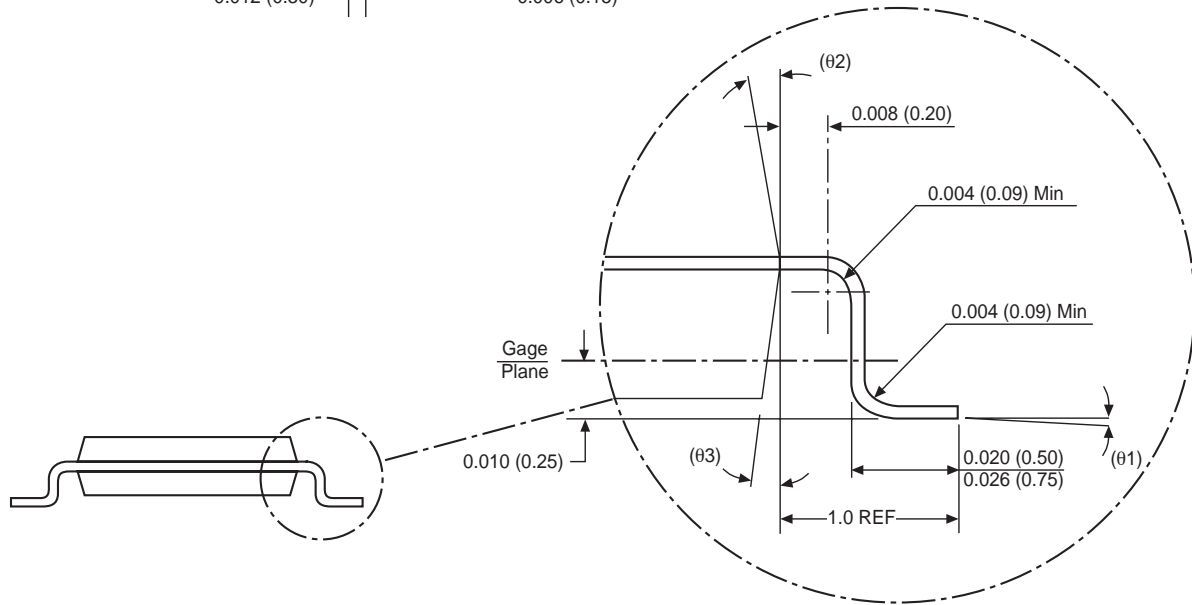
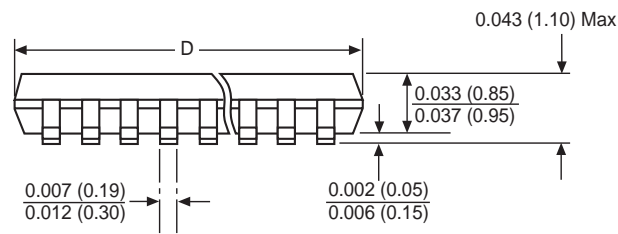

Figure 18. ESD Test Circuit for Human Body Model

# PACKAGE: PLASTIC THIN SMALL OUTLINE (TSSOP)



DIMENSIONS in inches (mm) Minimum/Maximum	
Symbol	20 Lead
D	0.252/0.260 (6.40/6.60)
e	0.026 BSC (0.65 BSC)



## ORDERING INFORMATION

Model	Temperature Range	Package Types
SP3203CY . . . . .	0°C to +70°C . . . . .	20-pin TSSOP
SP3203EY . . . . .	-40°C to +85°C . . . . .	20-pin TSSOP

Please consult the factory for pricing and availability on a Tape-On-Reel option.



ANALOG EXCELLENCE

**Sipex Corporation**

**Headquarters and  
Sales Office**  
233 South Hillview Drive  
Milpitas, CA 95035  
TEL: (408) 934-7500  
FAX: (408) 935-7600

**Sales Office**  
22 Linnell Circle  
Billerica, MA 01821  
TEL: (978) 667-8700  
FAX: (978) 670-9001  
e-mail: sales@sipex.com

Sipex Corporation reserves the right to make changes to any products described herein. Sipex does not assume any liability arising out of the application or use of any product or circuit described herein; neither does it convey any license under its patent rights nor the rights of others.