

## Quad RS-485/RS-422 Line Drivers

- RS-485 or RS-422 Applications
- Quad Differential Line Drivers
- Tri-state Output Control
- 40ns Typical Driver Propagation Delays
- 5ns Skew
- -7V to +12V Common Mode Output Range
- 100µA Supply Current
- Single +5V Supply Operation
- Pin Compatible with SN75172, SN75174, LTC486, and LTC487

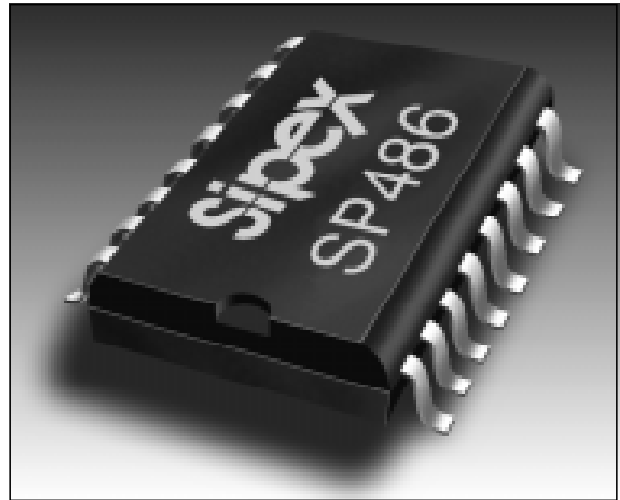

### DESCRIPTION...

The **SP486** and **SP487** are low-power quad differential line drivers meeting RS-485 and RS-422 standards. The **SP486** features a common driver enable control; the **SP487** provides independent driver enable controls for each pair of drivers. Both feature tri-state outputs and wide common-mode input range. Both are available in 16-pin plastic DIP and SOIC packages.

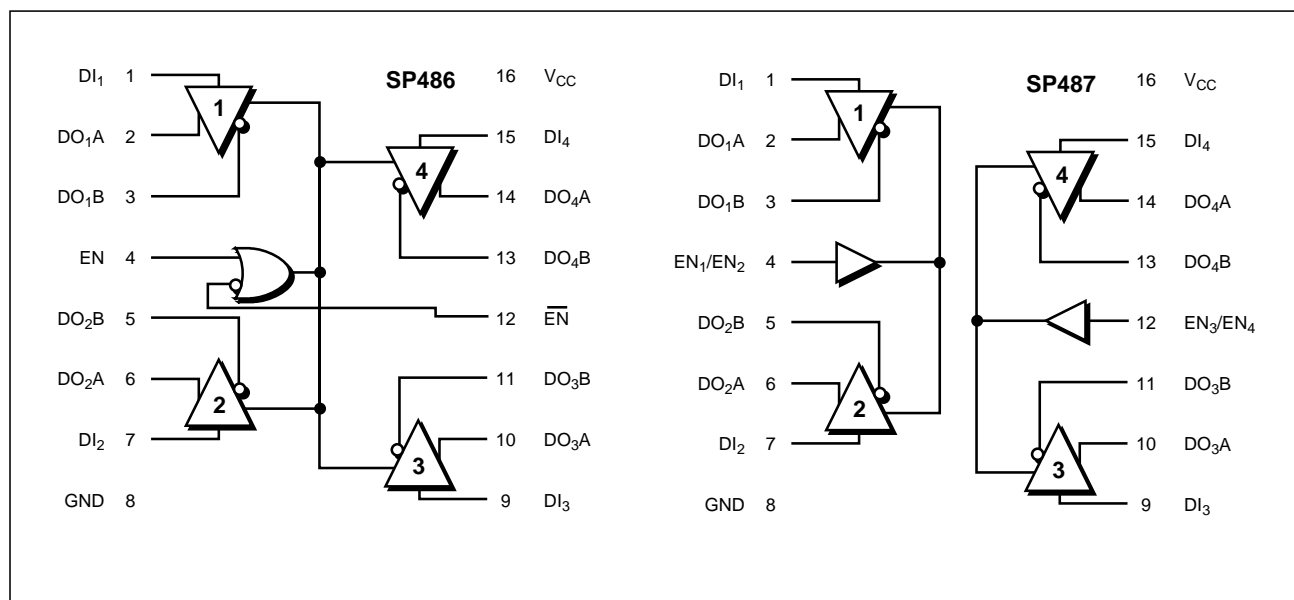

## ABSOLUTE MAXIMUM RATINGS

These are stress ratings only and functional operation of the device at these or any other above those indicated in the operation sections of the specifications below is not implied. Exposure to absolute maximum rating conditions for extended periods of time may affect reliability.

$V_{CC}$ .....	+7V
Input Voltages	
Logic .....	-0.5V to ( $V_{CC} + 0.5V$ )
Drivers .....	-0.5V to ( $V_{CC} + 0.5V$ )
Driver Output Voltage .....	$\pm 14V$
Input Currents	
Logic .....	$\pm 25mA$
Driver .....	$\pm 25mA$
Storage Temperature .....	-65°C to +150°C
Power Dissipation	
Plastic DIP .....	375mW
(derate 7mW/°C above +70°C)	
Small Outline .....	375mW
(derate 7mW/°C above +70°C)	
Lead Temperature (soldering, 10 sec) .....	300°C

## SPECIFICATIONS

$V_{CC} = 5V \pm 5\%$ ; typicals at 25°C;  $T_{MIN} \leq T_A \leq T_{MAX}$  unless otherwise noted.

PARAMETER	MIN.	TYP.	MAX.	UNIT	CONDITIONS
<b>DC CHARACTERISTICS</b>					
Digital Inputs					DI, EN, $\overline{EN}$ , EN <sub>1</sub> /EN <sub>2</sub> , EN <sub>3</sub> /EN <sub>4</sub>
Voltage			0.8	Volts	
$V_{IL}$	2.0			Volts	
$V_{IH}$				Volts	
Input Current			$\pm 2$	$\mu A$	$V_{IN} = 0V$ to $V_{CC}$
<b>DRIVER OUTPUTS</b>					
Differential Voltage			5	Volts	$I_O = 0$ ; unloaded
	2			Volts	$R_L = 50\Omega$ (RS-422)
	1.5	2	5	Volts	$R_L = 27\Omega$ (RS-485); Fig. 1
Change in Output Magnitude for Complementary Output State			0.2	Volts	$R_L = 27\Omega$ or $50\Omega$ ; Fig. 1
Common Mode Output Voltage		2.3	3	Volts	$R_L = 27\Omega$ or $50\Omega$ ; Fig. 1
Change in Common Mode Output Magnitude for Complementary Output State			0.2	Volts	$R_L = 27\Omega$ or $50\Omega$ ; Fig. 1
				Volts	$R_L = 50\Omega$ (RS-422)
				Volts	$R_L = 27\Omega$ (RS-485)
Maximum Data Rate	10			Mbps	
Short-circuit Current			$\pm 250$	mA	$-7V \leq V_O \leq +10V$
$V_{OH}$			$\pm 250$	mA	$-7V \leq V_O \leq +10V$
$V_{OL}$			$\pm 200$	$\mu A$	$V_O = -7V$ to $+10V$
High Impedance Output Current		$\pm 2$			
<b>POWER REQUIREMENTS</b>					
Supply Voltage	4.75	5.00	5.25	Volts	
Supply Current		0.5	10	$\mu A$	No load, output enabled
		0.5	10	$\mu A$	No load, output disabled
<b>ENVIRONMENTAL AND MECHANICAL</b>					
Operating Temperature					
-C	0		+70	°C	
-E	-40		+85	°C	
Storage Temperature	-65		+150	°C	
Package					
-_S	16-pin Plastic DIP				
-_T	16-pin SOIC				

## PINOUT — SP486

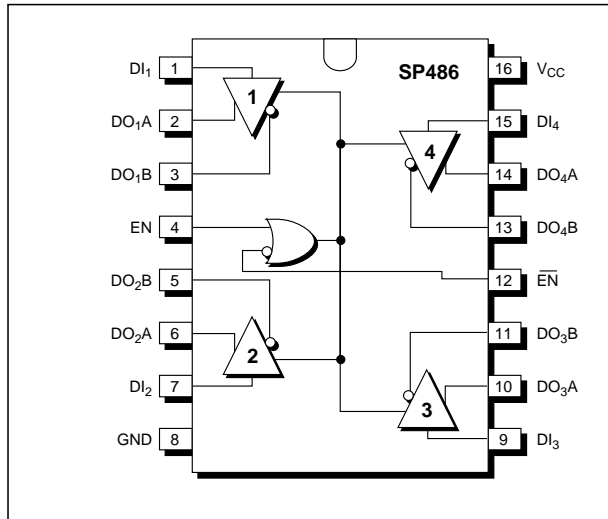

### SP486 PINOUT

Pin 1 — DI<sub>1</sub> — Driver 1 Input — If Driver 1 output is enabled, logic 0 on DI<sub>1</sub> forces driver output DO<sub>1</sub>A low and DO<sub>1</sub>B high. A logic 1 on DI<sub>1</sub> with Driver 1 output enabled forces driver DO<sub>1</sub>A high and DO<sub>1</sub>B low.

Pin 2 — DO<sub>1</sub>A — Driver 1 output A.

Pin 3 — DO<sub>1</sub>B — Driver 1 output B.

Pin 4 — EN — Driver Output Enable. Please refer to SP486 Truth Table (1).

Pin 5 — DO<sub>2</sub>B — Driver 2 output B.

Pin 6 — DO<sub>2</sub>A — Driver 2 output A.

Pin 7 — DI<sub>2</sub> — Driver 2 Input — If Driver 2 output is enabled, logic 0 on DI<sub>2</sub> forces driver output DO<sub>2</sub>A low and DO<sub>2</sub>B high. A logic 1 on DI<sub>2</sub> with Driver 2 output enabled forces driver DO<sub>2</sub>A high and DO<sub>2</sub>B low.

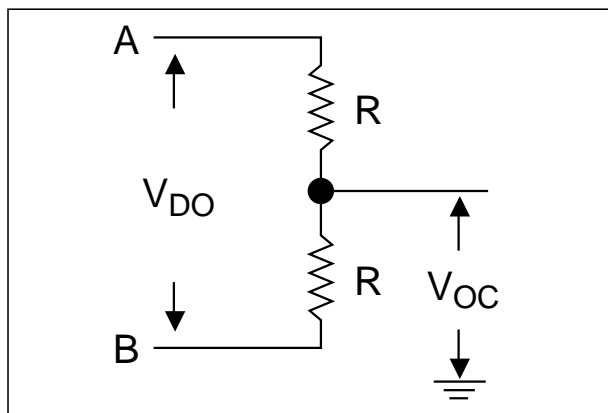

Figure 1. Driver DC Test Load

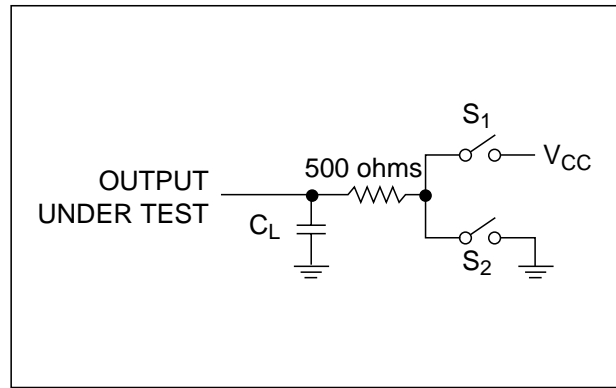

Figure 3. Driver Timing Test Load

Pin 8 — GND — Digital Ground.

Pin 9 — DI<sub>3</sub> — Driver 3 Input — If Driver 3 output is enabled, logic 0 on DI<sub>3</sub> forces driver output DO<sub>3</sub>A low and DO<sub>3</sub>B high. A logic 1 on DI<sub>3</sub> with Driver 3 output enabled forces driver DO<sub>3</sub>A high and DO<sub>3</sub>B low.

Pin 10 — DO<sub>3</sub>A — Driver 3 output A.

Pin 11 — DO<sub>3</sub>B — Driver 3 output B.

Pin 12 — EN̄ — Driver Output Disable. Please refer to SP486 Truth Table (1).

Pin 13 — DO<sub>4</sub>B — Driver 4 output B.

Pin 14 — DO<sub>4</sub>A — Driver 4 output A.

Pin 15 — DI<sub>4</sub> — Driver 4 Input — If Driver 4 output is enabled, logic 0 on DI<sub>4</sub> forces driver output DO<sub>4</sub>A low and DO<sub>4</sub>B high. A logic 1 on DI<sub>4</sub> with Driver 3 output enabled forces driver DO<sub>4</sub>A high and DO<sub>4</sub>B low.

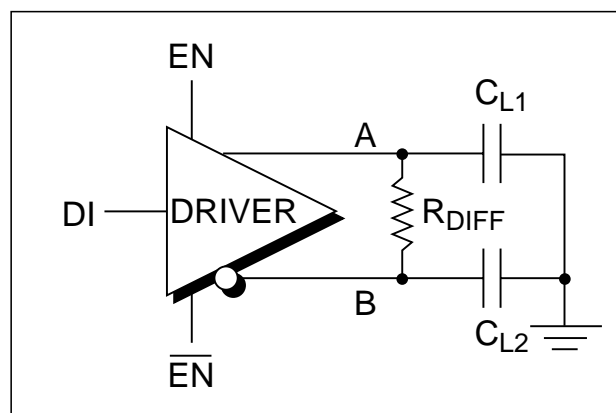
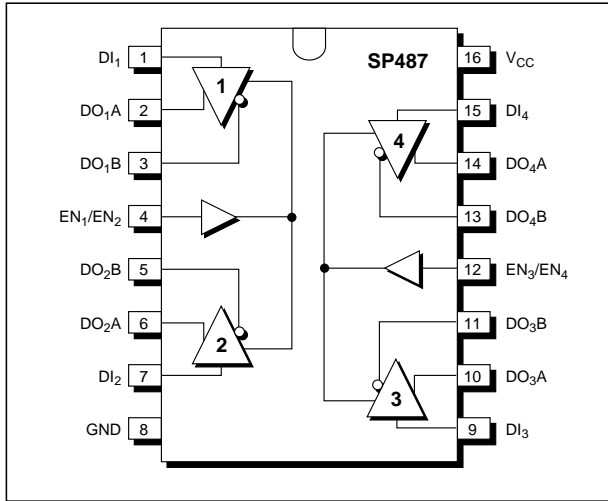

Figure 2. Driver Timing Test

## PINOUT — SP487



Pin 16 — Supply Voltage  $V_{CC}$  —  $4.75V \leq V_{CC} \leq 5.25V$ .

### SP487 PINOUT

Pin 1 —  $DI_1$  — Driver 1 Input — If Driver 1 output is enabled, logic 0 on  $DI_1$  forces driver output  $DO_1A$  low and  $DO_1B$  high. A logic 1 on  $DI_1$  with Driver 1 output enabled forces driver  $DO_1A$  high and  $DO_1B$  low.

Pin 2 —  $DO_1A$  — Driver 1 output A.

Pin 3 —  $DO_1B$  — Driver 1 output B.

Pin 4 —  $EN_1/EN_2$  — Driver 1 and 2 Output Enable. Please refer to SP487 Truth Table (2).

Pin 5 —  $DO_2B$  — Driver 2 output B.

Pin 6 —  $DO_2A$  — Driver 2 output A.

Pin 7 —  $DI_2$  — Driver 2 Input — If Driver 2 output is enabled, logic 0 on  $DI_2$  forces driver output  $DO_2A$  low and  $DO_2B$  high. A logic 1 on  $DI_2$  with Driver 2 output enabled forces driver  $DO_2A$  high and  $DO_2B$  low.

Pin 8 — GND — Digital Ground.

Pin 9 —  $DI_3$  — Driver 3 Input — If Driver 3 output is enabled, logic 0 on  $DI_3$  forces driver output  $DO_3A$  low and  $DO_3B$  high. A logic 1 on  $DI_3$  with Driver 3 output enabled forces driver  $DO_3A$  high and  $DO_3B$  low.

Pin 10 —  $DO_3A$  — Driver 3 output A.

INPUT	ENABLES		OUTPUTS	
DI	EN	$\overline{EN}$	OUTA	OUTB
H	H	X	H	L
L	H	X	L	H
H	X	L	H	L
L	X	L	L	H
X	L	H	Hi-Z	Hi-Z

Table 1. SP486 Truth Table

Pin 11 —  $DO_3B$  — Driver 3 output B.

Pin 12 —  $EN_3/EN_4$  — Driver 3 and 4 Output Enable. Please refer to SP487 Truth Table (2).

Pin 13 —  $DO_4B$  — Driver 4 output B.

Pin 14 —  $DO_4A$  — Driver 4 output A.

Pin 15 —  $DI_4$  — Driver 4 Input — If Driver 4 output is enabled, logic 0 on  $DI_4$  forces driver output  $DO_4A$  low and  $DO_4B$  high. A logic 1 on  $DI_4$  with Driver 3 output enabled forces driver  $DO_4A$  high and  $DO_4B$  low.

Pin 16 — Supply Voltage  $V_{CC}$  —  $4.75V \leq V_{CC} \leq 5.25V$ .

### FEATURES...

The **SP486** and **SP487** are low-power quad differential line drivers meeting RS-485 and RS-422 standards. The **SP486** features active high and active low common driver enable controls; the **SP487** provides independent, active high driver enable controls for each pair of drivers. The driver outputs are short-circuit limited to 200mA. Data rates up to 10Mbps are supported. Both are available in 16-pin plastic DIP and SOIC packages.

INPUT	ENABLES	OUTPUTS	
DI	EN1/EN2 or EN3/EN4	OUTA	OUTB
H	H	H	L
L	H	L	H
X	L	Hi-Z	Hi-Z

Table 2. SP487 Truth Table

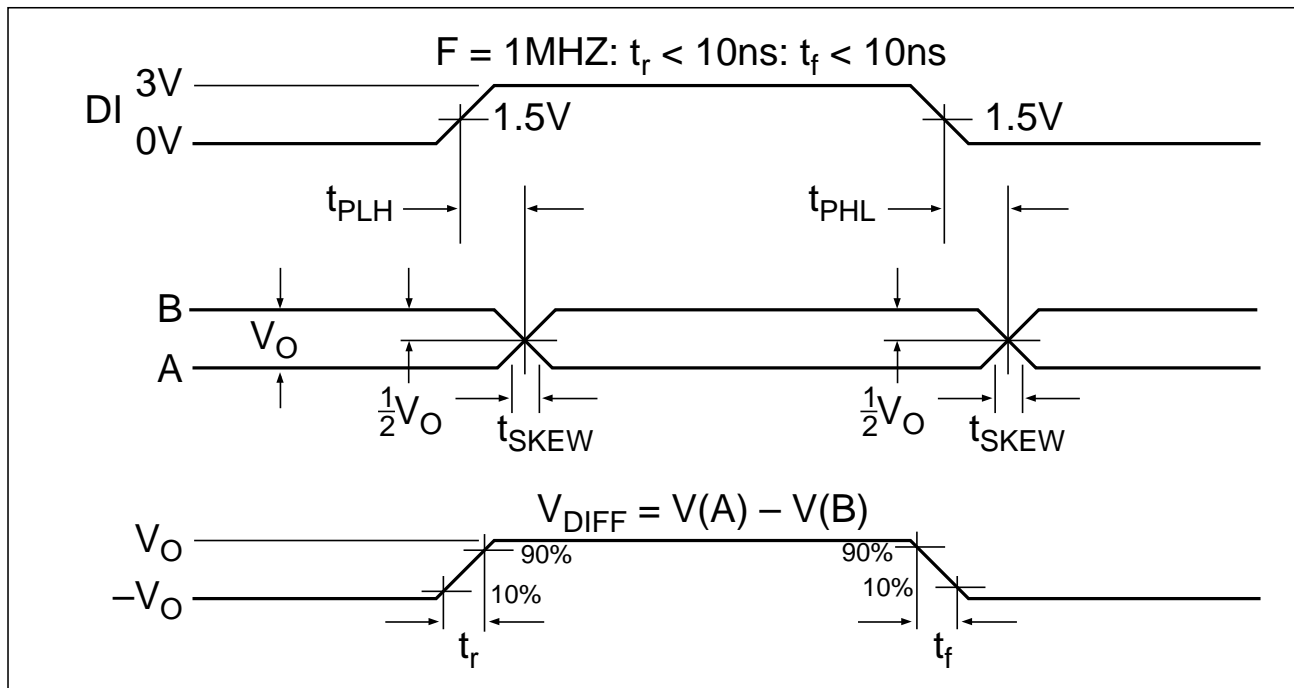

Figure 4. Driver Propagation Delays

## AC PARAMETERS

$V_{CC} = 5V \pm 5\%$ ; typicals at  $25^{\circ}C$ ;  $0^{\circ}C \leq T_A \leq +70^{\circ}C$  unless otherwise noted.

PARAMETER	MIN.	TYP.	MAX.	UNIT	CONDITIONS
<b>PROPAGATION DELAY</b>					
Driver Input to Output					$R_{DIFF} = 54 \text{ Ohms}$ , $C_{L1} = C_{L2} = 100\text{pF}$ ; Figure 2
Low to High ( $t_{PLH}$ )	20	40	60	ns	
High to Low ( $t_{PHL}$ )	20	40	60	ns	
Driver Output to Output ( $t_{SKEW}$ )		5	15	ns	
Driver Rise Time ( $t_r$ )					10% to 90%
SP486		20		ns	
SP487		20		ns	
Driver Fall Time ( $t_f$ )					90% to 10%
SP486		20		ns	
SP487		20		ns	
<b>DRIVER ENABLE</b>					
To Output High		60	110	ns	$C_L = 100\text{pF}$ ; Figures 3 and 5 ( $S_2$ closed)
To Output Low		60	115	ns	$C_L = 100\text{pF}$ ; Figures 3 and 5 ( $S_1$ closed)
<b>DRIVER DISABLE</b>					
From Output Low		60	130	ns	$C_L = 15\text{pF}$ ; Figures 3 and 5 ( $S_1$ closed)
From Output High		60	130	ns	$C_L = 15\text{pF}$ ; Figures 3 and 5 ( $S_2$ closed)

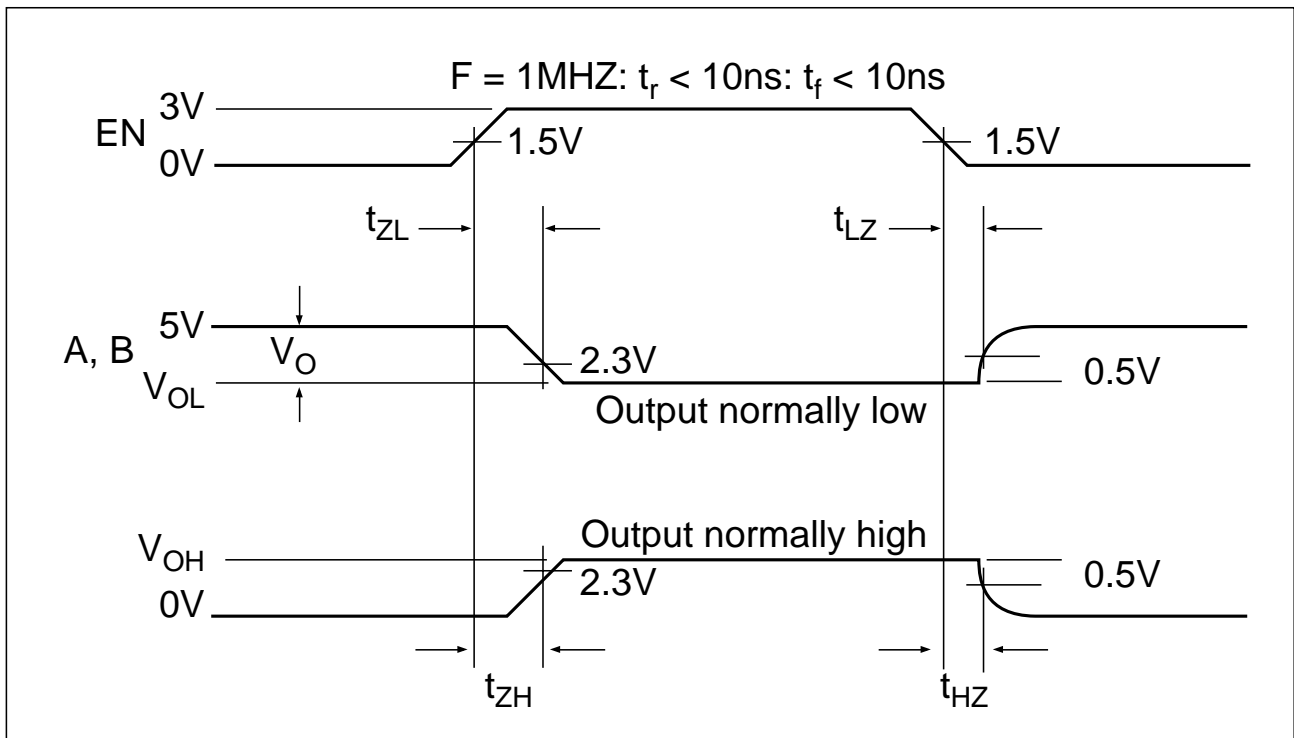

Figure 5. Driver Enable/Disable Timing

## ORDERING INFORMATION

### Quad RS485 Drivers:

Model	Enable/Disable	Temperature Range	Package
SP486CS	Common; active Low and Active High	0°C to +70°C	16-pin Plastic DIP
SP486CT	Common; active Low and Active High	0°C to +70°C	16-pin SOIC
SP486ES	Common; active Low and Active High	-40°C to +85°C	16-pin Plastic DIP
SP486ET	Common; active Low and Active High	-40°C to +85°C	16-pin SOIC
SP487CS	One per driver pair; active High	0°C to +70°C	16-pin Plastic DIP
SP487CT	One per driver pair; active High	0°C to +70°C	16-pin SOIC
SP487ES	One per driver pair; active High	-40°C to +85°C	16-pin Plastic DIP
SP487ET	One per driver pair; active High	-40°C to +85°C	16-pin SOIC



SIGNAL PROCESSING EXCELLENCE

**Sipex Corporation**

**Headquarters and  
Sales Office**

22 Linnell Circle  
Billerica, MA 01821  
TEL: (978) 667-8700  
FAX: (978) 670-9001  
e-mail: sales@sipex.com

**Sales Office**

233 South Hillview Drive  
Milpitas, CA 95035  
TEL: (408) 934-7500  
FAX: (408) 935-7600

Sipex Corporation reserves the right to make changes to any products described herein. Sipex does not assume any liability arising out of the application or use of any product or circuit described hereing; neither does it convey any license under its patent rights nor the rights of others.