

# XC62E Series

Boosting Voltage Regulators



- ◆ CMOS Low Power Consumption
- ◆ Small Input-Output Voltage Differential  
: 0.1V @ 100mA
- ◆ Maximum Output Current : 1000mA
- ◆ Output Voltage Range : 2V~6V
- ◆ Output Voltage Accuracy : ±2%

## Applications

- Portable Cameras and Video Recorders
- Battery Powered Equipment
- Palmtops
- Reference Voltage Sources

3

## General Description

The XC62E series are a group of positive output voltage regulators that can supply up to 1A of output current using an external transistor. Low power and high accuracy are achieved through CMOS process and laser trimming technologies.

The series consists of a high precision voltage reference, an error correction circuit and a short-circuit protected output driver.

In stand-by mode, supply current can be dramatically cut. Since the input-output voltage differential is small, loss control efficiency is good.

The XC62E is particularly suited for use with battery operated portable products, and products where supply current regulation is required.

The series comes in an ultra small SOT-25 package.

In connection with the CE function, apart from the negative logic XC62EP series, a positive logic XC62ER series (custom) is also available.

## Features

- Ultra Small Input-Output Voltage Differential**  
: 100mA of output current is available with a differential of 0.1V. (Performance depends on the external transistor characteristics.)
- Maximum Output Current** : 1000mA
- Output Voltage Range** : 2V ~ 6V in 0.1V increments
- Highly Accurate** : Set-up voltage ±2%
- Low Power Consumption** : Typ.50µA (V<sub>OUT</sub>=5.0V)  
: Typ.0.2µA (Stand-by)
- Output Voltage Temperature Characteristics**  
: Typ.±100ppm/°C
- Input Stability** : Typ.0.1%/V
- Ultra Small Packages** : SOT-25 mini-mold

## Typical Application Circuit

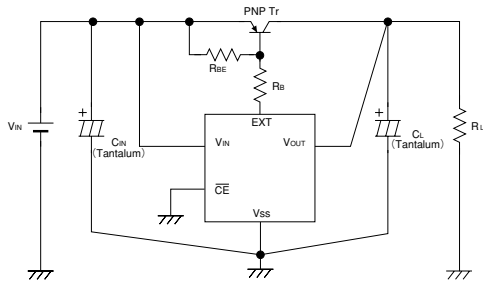

## Typical Performance Characteristic

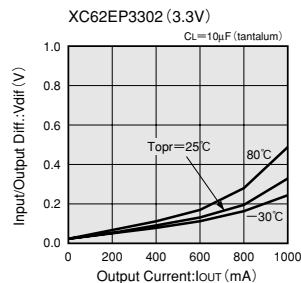

## XC62E Series

### Pin Configuration

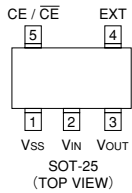

### Pin Assignment

PIN NUMBER	PIN NAME	FUNCTION
1	V <sub>SS</sub>	Ground
2	V <sub>IN</sub>	Supply voltage input
3	V <sub>OUT</sub>	Regulated voltage output
4	EXT	Base current control
5	CE/ $\overline{\text{CE}}$	Chip enable

3

### Function

SERIES	CE	OUTPUT VOLTAGE
XC62ER	H	ON
	L	OFF
XC62EP	H	OFF
	L	ON

H=High Level  
L=Low Level

### Product Classification

#### Ordering Information

X C 6 2 E X X X X X X X  
 ↑ ↑ ↑ ↑ ↑ ↑ ↑  
 a b c d e f

DESIGNATOR	DESCRIPTION	DESIGNATOR	DESCRIPTION
a	<u>CE pin Logic:</u> R=Positive P=Negative	e	<u>Package Type</u> M=SOT-25
b	<u>Output Voltage</u> 30=3.0V 50=5.0V		
c	<u>Temperature Coefficients:</u> 0=±100ppm (typical)	f	<u>Device Orientation</u> R=Embossed Tape (Standard Feed) L=Embossed Tape (Reverse Feed)
d	<u>Output Voltage Accuracy:</u> 1=±1.0%(Semi-custom) 2=±2.0%		

## ■ Packaging Information

● SOT-25

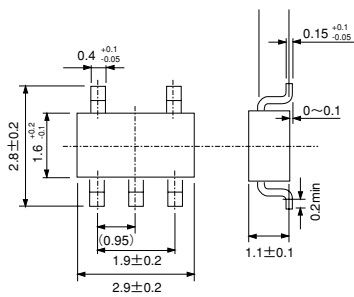

3

## ■ Marking

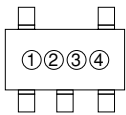

SOT-25  
(TOP VIEW)

① Not Used

② Represents the integer of the Output Voltage

R TYPE POSITIVE VOLTAGE LOGIC SYMBOL	VOLTAGE(V)	P TYPE NEGATIVE VOLTAGE LOGIC SYMBOL	VOLTAGE(V)
$\bar{2}$	2.③	2	2.③
$\bar{3}$	3.③	3	3.③
$\bar{4}$	4.③	4	4.③
$\bar{5}$	5.③	5	5.③
$\bar{6}$	6.③	6	6.③

③ Represents the decimal number of the Output Voltage

R TYPE POSITIVE VOLTAGE LOGIC SYMBOL	VOLTAGE(V)	P TYPE NEGATIVE VOLTAGE LOGIC SYMBOL	VOLTAGE(V)
$\bar{0}$	②.0	0	②.0
$\bar{1}$	②.1	1	②.1
$\bar{2}$	②.2	2	②.2
$\bar{3}$	②.3	3	②.3
$\bar{4}$	②.4	4	②.4
$\bar{5}$	②.5	5	②.5
$\bar{6}$	②.6	6	②.6
$\bar{7}$	②.7	7	②.7
$\bar{8}$	②.8	8	②.8
$\bar{9}$	②.9	9	②.9

④ Based on internal standards



## Electrical Characteristics

XC62EP3002  $V_{OUT}(T)=3.0V$  (Note1)

$T_a=25^{\circ}C$

PARAMETER	SYMBOL	CONDITIONS	MIN	TYP	MAX	UNITS
Output Voltage	$V_{OUT}(E)$ (Note2)	$I_{OUT}=50mA$ $V_{IN}=4.0V$	2.940	3.000	3.060	V
Maximum Output Current*	$I_{OUT\ max.}$	$V_{IN}=4.0V$		1000		mA
Load Stability*	$\Delta V_{OUT}$	$V_{IN}=4.0V$ $1mA \leq I_{OUT} \leq 100mA$	-60		60	mV
Input-Output Voltage Differential (Note3)	$V_{dif}$	$I_{OUT}=100mA$		100		mV
Supply Current1	$I_{SS1}$	$V_{IN}=4.0V, V_{CE}=V_{SS}$		50	80	$\mu A$
Supply Current2	$I_{SS2}$	$V_{IN}=8.0V, V_{CE}=V_{IN}$			0.6	$\mu A$
Input Stability*	$\frac{\Delta V_{OUT}}{\Delta V_{IN} \cdot V_{OUT}}$	$I_{OUT}=50mA$ $4.0V \leq V_{IN} \leq 8.0V$		0.1	0.3	%/V
Input Voltage	$V_{IN}$				8	V
Output Voltage Temperature Characteristics*	$\frac{\Delta V_{OUT}}{\Delta T_{opr} \cdot V_{OUT}}$	$I_{OUT}=10mA$ $-30^{\circ}C \leq T_{opr} \leq 80^{\circ}C$		$\pm 100$		ppm/ $^{\circ}C$
EXT Output Voltage	$V_{EXT}$				8	V
EXT Leak Current	$I_{LEAK}$				0.5	$\mu A$
$\overline{CE}$ "High" Level Voltage	$V_{CEH}$		1.5			V
$\overline{CE}$ "Low" Level Voltage	$V_{CEL}$				0.25	V
$\overline{CE}$ "High" Level Current	$I_{CEH}$	$V_{CE}=V_{IN}$			0.1	$\mu A$
$\overline{CE}$ "Low" Level Current	$I_{CEL}$	$V_{CE}=V_{SS}$	-0.2	-0.05	0	$\mu A$

The characteristics for the XC62ER series are the same as above except for the CE operating logic which is the opposite.

- Note:
- $V_{OUT}(T)$ =Specified Output Voltage.
  - $V_{OUT}(E)$ =Effective Output Voltage (i.e. the output voltage when " $V_{OUT}(T)+1.0V$ " is provided at the  $V_{IN}$  pin while maintaining a certain  $I_{OUT}$  value).
  - $V_{dif} = \{V_{IN1} \text{ (Note5)}, V_{OUT1} \text{ (Note4)}\}$
  - $V_{OUT1}$ = A voltage equal to 98% of the Output Voltage whenever an amply stabilised  $I_{OUT}$  ( $V_{OUT}(T)+1.0V$ ) is input.
  - $V_{IN1}$ = The Input Voltage when  $V_{OUT1}$  appears as Input Voltage is gradually decreased.
  - The characteristics for those parameters marked with an asterisk\* are liable to vary depending on which transistor is used.  
Please use a transistor with a low saturation voltage level and  $h_{FE}$  equal to 100 or more.
  - The maximum output current value is not a value representing continuous output due to the limitations of the 2AS1213 transistor's power dissipation.

3

## XC62E Series

XC62EP4002  $V_{OUT}(T)=4.0V$  (Note1)

$T_a=25^\circ C$

PARAMETER	SYMBOL	CONDITIONS	MIN	TYP	MAX	UNITS
Output Voltage	$V_{OUT}(E)$ (Note2)	$I_{OUT}=50mA$ $V_{IN}=5.0V$	3.920	4.000	4.080	V
Maximum Output Current*	$I_{OUT\ max.}$	$V_{IN}=5.0V$		1000		mA
Load Stability*	$\Delta V_{OUT}$	$V_{IN}=5.0V$ $1mA \leq I_{OUT} \leq 100mA$	-60		60	mV
Input-Output Voltage Differential (Note3)	$V_{dif}$	$I_{OUT}=100mA$		100		mV
Supply Current1	$I_{SS1}$	$V_{IN}=5.0V, V_{CE}=V_{SS}$		50	80	$\mu A$
Supply Current2	$I_{SS2}$	$V_{IN}=8.0V, V_{CE}=V_{IN}$			0.6	$\mu A$
Input Stability*	$\frac{\Delta V_{OUT}}{\Delta V_{IN} \cdot V_{OUT}}$	$I_{OUT}=50mA$ $5.0V \leq V_{IN} \leq 8.0V$		0.1	0.3	%/V
Input Voltage	$V_{IN}$				8	V
Output Voltage Temperature Characteristics*	$\frac{\Delta V_{OUT}}{\Delta T_{opr} \cdot V_{OUT}}$	$I_{OUT}=10mA$ $-30^\circ C \leq T_{opr} \leq 80^\circ C$		$\pm 100$		ppm/ $^\circ C$
EXT Output Voltage	$V_{EXT}$				8	V
EXT Leak Current	$I_{LEAK}$				0.5	$\mu A$
$\overline{CE}$ "High" Level Voltage	$V_{CEH}$		1.5			V
$\overline{CE}$ "Low" Level Voltage	$V_{CEL}$				0.25	V
$\overline{CE}$ "High" Level Current	$I_{CEH}$	$V_{CE}=V_{IN}$			0.1	$\mu A$
$\overline{CE}$ "Low" Level Current	$I_{CEL}$	$V_{CE}=V_{SS}$	-0.2	-0.05	0	$\mu A$

XC62EP5002  $V_{OUT}(T)=5.0V$  (Note1)

$T_a=25^\circ C$

PARAMETER	SYMBOL	CONDITIONS	MIN	TYP	MAX	UNITS
Output Voltage	$V_{OUT}(E)$ (Note2)	$I_{OUT}=50mA$ $V_{IN}=6.0V$	4.900	5.000	5.100	V
Maximum Output Current*	$I_{OUT\ max.}$	$V_{IN}=6.0V$		1000		mA
Load Stability*	$\Delta V_{OUT}$	$V_{IN}=6.0V$ $1mA \leq I_{OUT} \leq 100mA$	-60		60	mV
Input-Output Voltage Differential (Note3)	$V_{dif}$	$I_{OUT}=100mA$		100		mV
Supply Current1	$I_{SS1}$	$V_{IN}=6.0V, V_{CE}=V_{SS}$		50	80	$\mu A$
Supply Current2	$I_{SS2}$	$V_{IN}=8.0V, V_{CE}=V_{IN}$			0.6	$\mu A$
Input Stability*	$\frac{\Delta V_{OUT}}{\Delta V_{IN} \cdot V_{OUT}}$	$I_{OUT}=50mA$ $6.0V \leq V_{IN} \leq 8.0V$		0.1	0.3	%/V
Input Voltage	$V_{IN}$				8	V
Output Voltage Temperature Characteristics*	$\frac{\Delta V_{OUT}}{\Delta T_{opr} \cdot V_{OUT}}$	$I_{OUT}=10mA$ $-30^\circ C \leq T_{opr} \leq 80^\circ C$		$\pm 100$		ppm/ $^\circ C$
EXT Output Voltage	$V_{EXT}$				8	V
EXT Leak Current	$I_{LEAK}$				0.5	$\mu A$
$\overline{CE}$ "High" Level Voltage	$V_{CEH}$		1.5			V
$\overline{CE}$ "Low" Level Voltage	$V_{CEL}$				0.25	V
$\overline{CE}$ "High" Level Current	$I_{CEH}$	$V_{CE}=V_{IN}$			0.1	$\mu A$
$\overline{CE}$ "Low" Level Current	$I_{CEL}$	$V_{CE}=V_{SS}$	-0.2	-0.05	0	$\mu A$

The characteristics for the XC62ER series are the same as above except for the CE operating logic which is the opposite.

- Note:
- $V_{OUT}(T)$ =Specified Output Voltage.
  - $V_{OUT}(E)$ =Effective Output Voltage (i.e. the output voltage when " $V_{OUT}(T)+1.0V$ " is provided at the  $V_{IN}$  pin while maintaining a certain  $I_{OUT}$  value).
  - $V_{dif} = \{V_{IN1} (Note5) - V_{OUT1} (Note4)\}$
  - $V_{OUT1}$ = A voltage equal to 98% of the Output Voltage whenever an amply stabilised  $I_{OUT}$  ( $V_{OUT}(T)+1.0V$ ) is input.
  - $V_{IN1}$ = The Input Voltage when  $V_{OUT1}$  appears as Input Voltage is gradually decreased.
  - The characteristics for those parameters marked with an asterisk are liable to vary depending on which transistor is used.  
Please use a transistor with a low saturation voltage level and  $h_{FE}$  equal to 100 or more.
  - The maximum output current value is not a value representing continuous output due to the limitations of the 2AS1213 transistor's power dissipation.

## Typical Application Circuit

### Standard Circuit

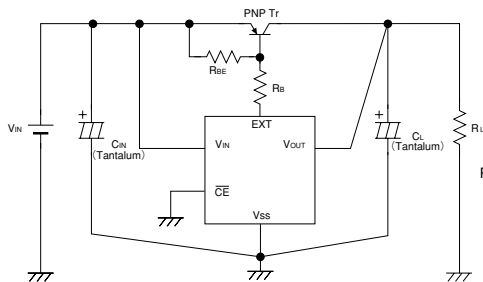

#### Peripherals :

- PNP Tr : 2SA1213
- R<sub>BE</sub> : 20kΩ~47kΩ
- R<sub>B</sub> : Please refer to Note 2 on the following page.
- C<sub>IN</sub> : 10μF(Tantalum)
- C<sub>L</sub> : 47μF(Tantalum) 10μF minimum

3

## Operational Explanation

### Functional Description

Output voltage (V<sub>OUT</sub>) can be fixed by revising the external transistor's base current. This can be done by comparing the detected voltage level and the set voltage power supply level.

With the XC62EP (CE negative voltage), if a voltage above the  $\overline{\text{CE}}$  pin's "H" level is applied, the IC will enter stand-by mode where the base and differential amplifier's currents are regulated.

## Directions for use

### Suggestions for External Components

#### 1. PNP Transistor

The selection of a transistor should take into account output current, input voltage and power dissipation for each specific application. It is recommended that a transistor that has a low output saturated voltage (V<sub>CE</sub>) and high h<sub>FE</sub> characteristics be used.

#### 2. R<sub>B</sub> Resistor

Although the IC unit is protected by a base current remitter circuit, it is recommended that a resistor (R<sub>B</sub>) be connected between the transistor's base and the IC's EXT pin to protect the transistor.

Required output current can be calculated using the following equation although characteristic variations and conditions of use should be carefully checked before use. The following equation also indicates the conditions needed to obtain I<sub>OUT</sub>(max.) at V<sub>IN</sub>(min.). However, the larger the input current, the larger the output current (I<sub>OUT</sub>) that can be obtained.

$$\frac{V_{IN}(\text{min})-1.2(\text{V})}{R_B} - \frac{0.7(\text{V})}{R_{BE}} > \frac{I_{OUT}(\text{max})}{h_{FE}}$$

#### 3. R<sub>BE</sub> Resistor, C<sub>L</sub> Capacitor

To prevent oscillation due to output load variation, use of a phase compensation capacitor C<sub>L</sub> is recommended. Please use a Tantalum capacitor of at least 10μF. Please also use an R<sub>BE</sub> resistor of less than 47kΩ.

An R<sub>BE</sub> resistor of between 20kΩ and 47kΩ is recommended for less power consumption.

#### 4. Input Impedance

In order to control oscillation brought about as a result of impedance at the power supply line, connect a capacitor of 10μF or more (Tantalum) between the external transistor's emitter and the ground pin.

### Special Note

#### 1. Protection Circuit

The built-in protect circuit is to protect the IC only. Therefore to prevent output shorts and overshoot current through the transistor, use of a resistor R<sub>B</sub> or an overshoot current protection circuit is recommended.

Care should also be taken with the transistor's power dissipation.

# XC62E Series

## Typical Performance Characteristics

### (1) OUTPUT VOLTAGE vs. OUTPUT CURRENT

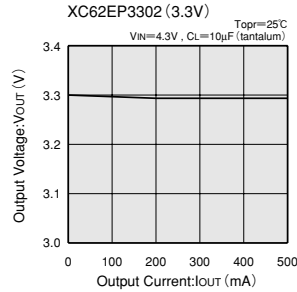
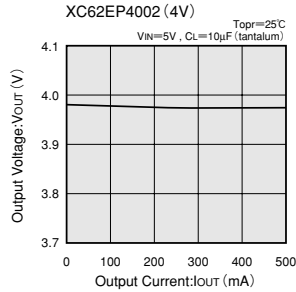
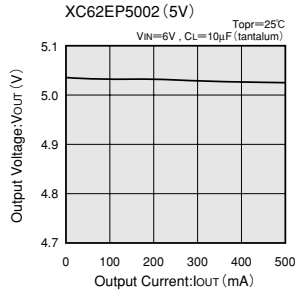

### (2) OUTPUT VOLTAGE vs. INPUT VOLTAGE

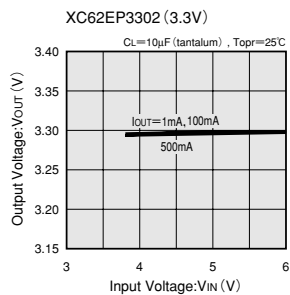
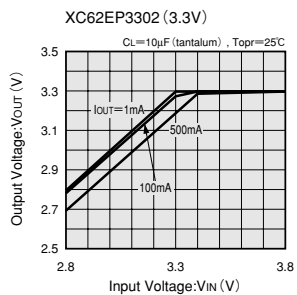
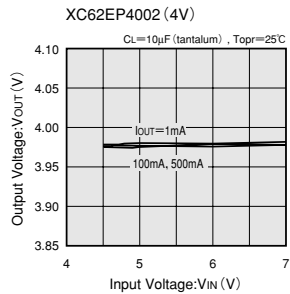
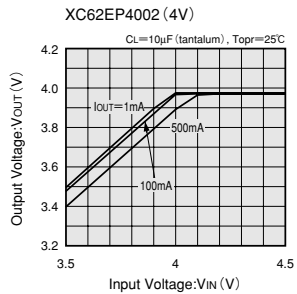
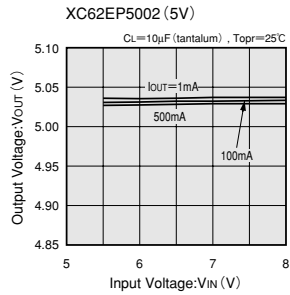
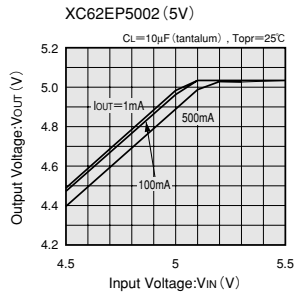



**(3) INPUT/OUTPUT VOLTAGE DIFFERENTIAL vs. OUTPUT CURRENT**  
XC62EP5002 (5V)      XC62EP4002 (4V)

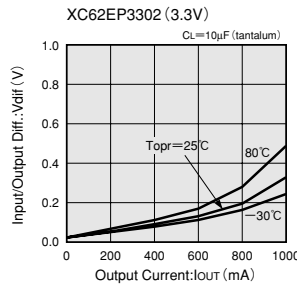
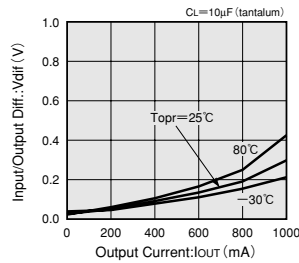
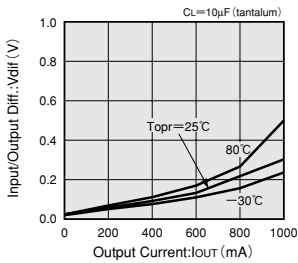

**3**

**(4) SUPPLY CURRENT vs. INPUT VOLTAGE**  
XC62EP5002 (5V)      XC62EP4002 (4V)

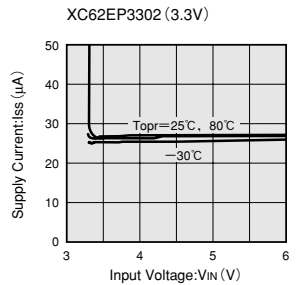
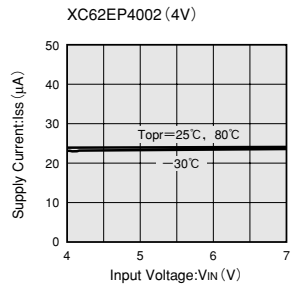
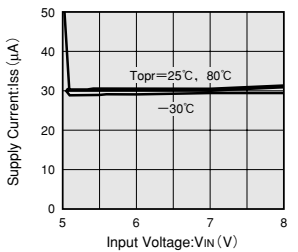

**(5) OUTPUT VOLTAGE vs. AMBIENT TEMPERATURE**  
XC62EP5002 (5V)      XC62EP4002 (4V)

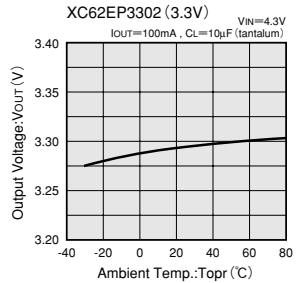
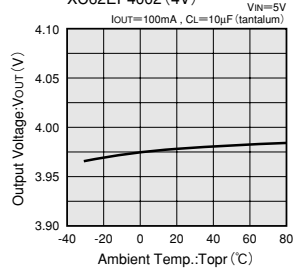
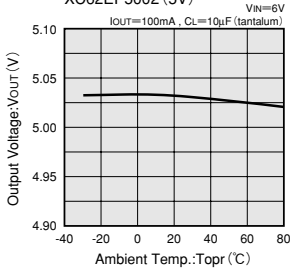

**(6) SUPPLY CURRENT vs. AMBIENT TEMPERATURE**  
XC62EP5002 (5V)      XC62EP4002 (4V)

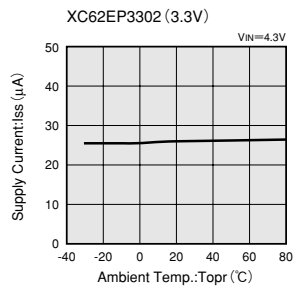
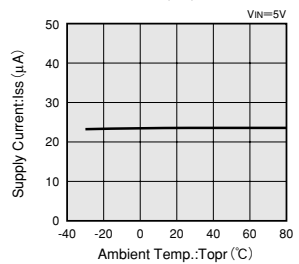
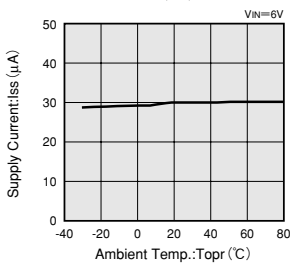

## XC62E Series

### (7) INPUT TRANSIENT RESPONSE

3

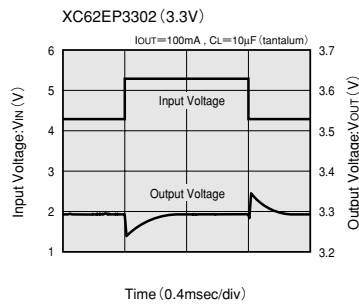
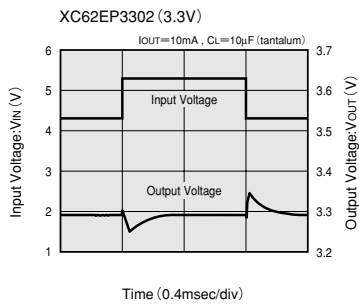
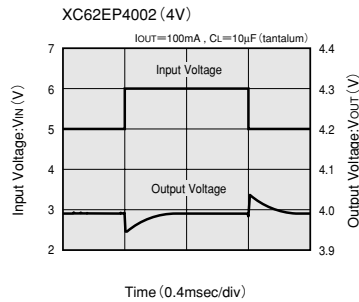
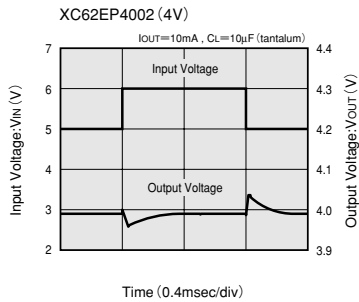
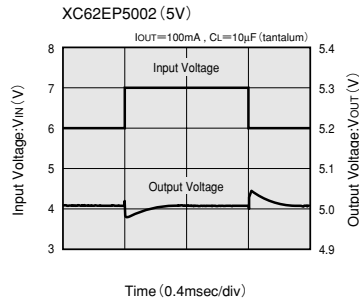
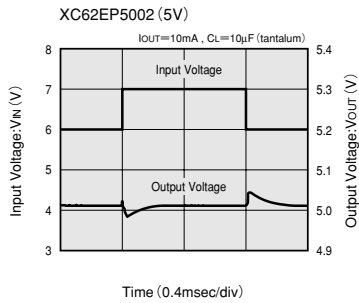

**(8) LOAD TRANSIENT RESPONSE**

XC62EP5002 (5V)

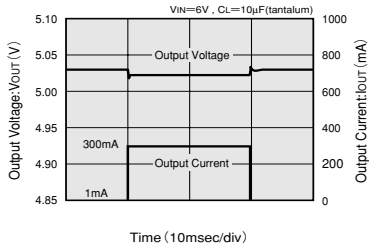

XC62EP4002 (4V)

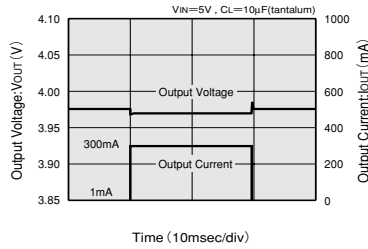

XC62EP3302 (3.3V)

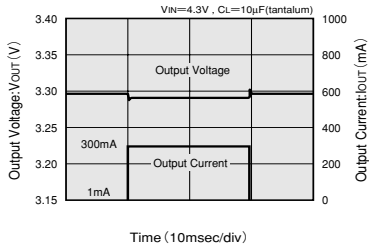

3

**(9) RIPPLE REJECTION RATE**

XC62EP5002 (5V)

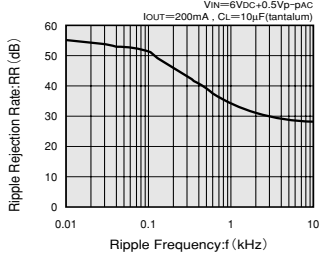

XC62EP4002 (4V)

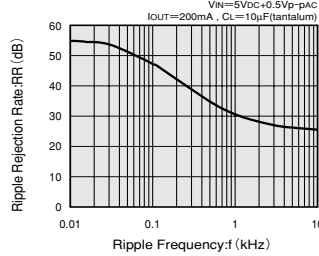

XC62EP3302 (3.3V)

