

SUPPLY VOLTAGE MONITOR

ISSUE 1 - MARCH 1998

ZSH560

DEVICE DESCRIPTION

The ZSH560 is a three terminal under voltage monitor circuit for use in microprocessor systems. The threshold voltage of the device has been set to 4.6 volts making it ideal for 5 volt circuits.

Included in the device is a precise voltage reference and a comparator with built in hysteresis to prevent erratic operation. The ZSH560 features an open collector output capable of sourcing at least 10mA which only requires a single external resistor to interface to following circuits.

Operation of the device is guaranteed from one volt upwards, from this level to the device threshold voltage the output is held high providing a power on reset function. Should the supply voltage, once established, at any time drop below the threshold level then the output again will pull high.

The device is available in a TO92 package for through hole applications as well as SO8 and SOT223 for surface mount requirements.

FEATURES

- SO8, SOT223 and TO92 packages
- Power on reset generator
- Automatic reset generation
- Low standby current
- Guaranteed operation from 1 volt
- Wide supply voltage range
- Internal clamp diode to discharge delay capacitor
- 4.6 volt threshold for 5 volt logic
- 20mV hysteresis prevents erratic operation

APPLICATIONS

- Microprocessor systems
- Computers
- Computer peripherals
- Instrumentation
- Automotive
- Battery powered equipment

SCHEMATIC DIAGRAM

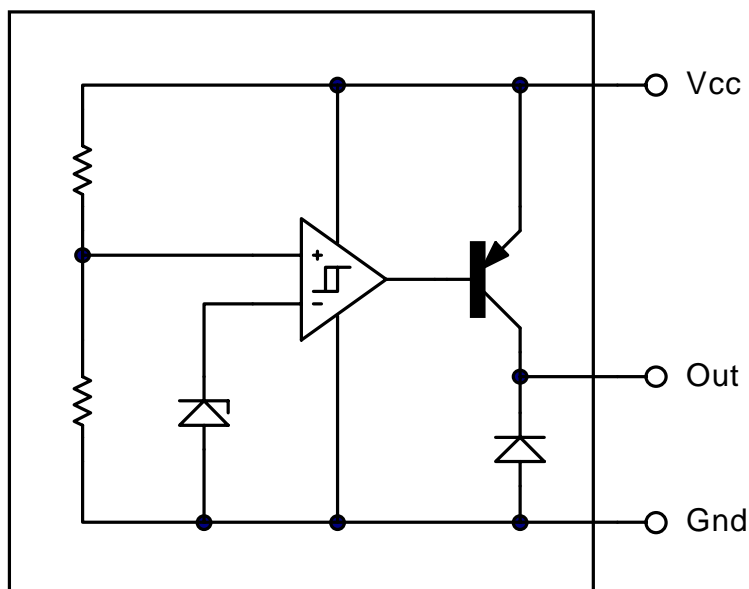

ZSH560

ABSOLUTE MAXIMUM RATING

Input Supply Voltage	-1 to 10V
Offstate Output Voltage	10V
Onstate Output Source Current(Note 1)	Internally limited
Clamp Diode Forward Current(Note 1)	100mA
Operating Junction Temperature	150°C
Operating Temperature	-40 to 85°C
Storage Temperature	-55 to 150°C

Power Dissipation

TO92	780mW
SOT223	2W(Note 2)
SO8	780mW(Note 2)

TEST CONDITIONS

($T_{amb}=25^{\circ}\text{C}$ for typical values, $T_{amb}=-40$ to 85°C for min/max values (Note3))

COMPARATOR

PARAMETER	SYMBOL	MIN	TYP.	MAX.	UNITS
Threshold Voltage Low state output (V_{cc} increasing)	V_{IL}	4.5	4.61	4.7	V
Threshold Voltage High state output (V_{cc} decreasing)	V_{IH}	4.5	4.59	4.7	V
Hysteresis	V_H	0.01	0.02	0.05	V

OUTPUT

PARAMETER	SYMBOL	MIN	TYP.	MAX.	UNITS
Output source saturation: ($V_{cc}=4.0\text{V}$, $I_{source}=8.0\text{mA}$) ($V_{cc}=4.0\text{V}$, $I_{source}=2.0\text{mA}$) ($V_{cc}=1.0\text{V}$, $I_{source}=2\mu\text{A}$)	V_{OH}			$V_{CC}-1.3$ $V_{CC}-1.2$ $V_{CC}-0.4$	V V V
Onstate output source current ($V_{cc}=4.0\text{V}$, Output=0V)	I_{source}	10	20	50	mA
Offstate output leakage current ($V_{cc}=5.0\text{V}$, Output=0V)	I_{oh}		0.02	0.5	μA
Clamp diode forward voltage ($I_f=10\text{mA}$)	V_f	0.6	1.2	1.5	V
Propagation delay (V_{in} 5V to 4V, $R_I=10\text{k}$, $T_{amb}=25^{\circ}\text{C}$)	T_d		1.5		μs

TOTAL DEVICE

PARAMETER	SYMBOL	MIN	TYP.	MAX.	UNITS
Operating input voltage range	V_{cc}	1.0 to 6.5			V
Quiescent input current ($V_{cc}=5\text{V}$)	I_q		135	200	μA

Note:

1. Maximum package power dissipation must be observed.
2. Maximum power dissipation, for the SOT223 and SO8 packages, is calculated assuming that the device is mounted on a PCB measuring 2 inches square.
3. Low duty cycle pulse techniques are used during test to maintain junction temperatures as close to ambient as possible.

ZSH560

TYPICAL CHARACTERISTICS

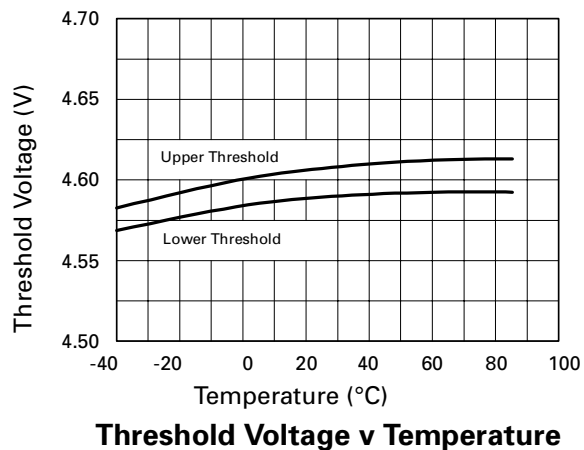
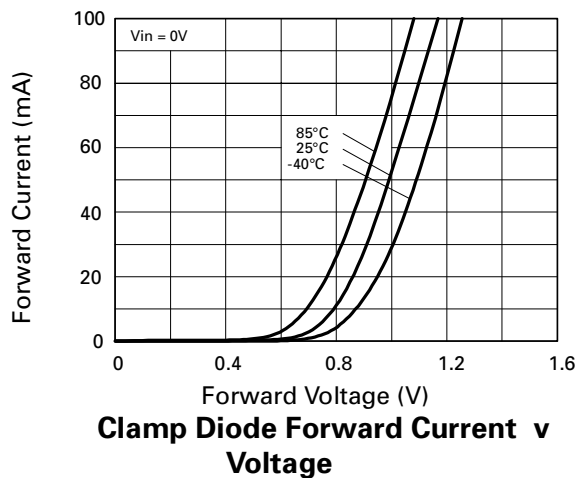
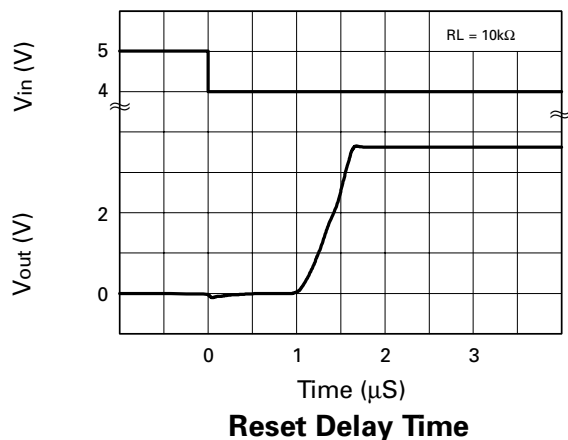
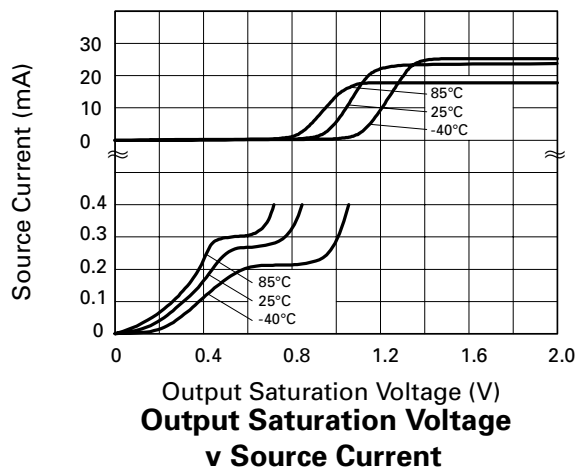
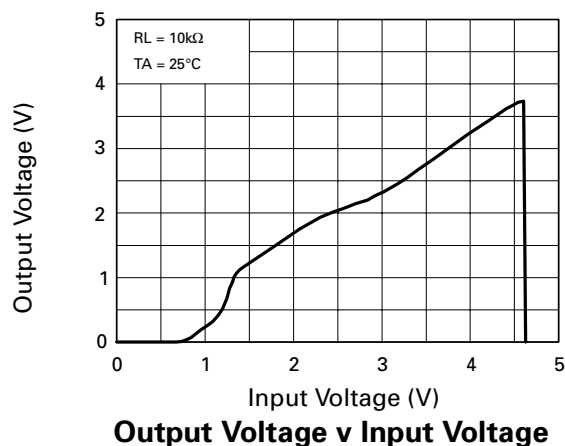
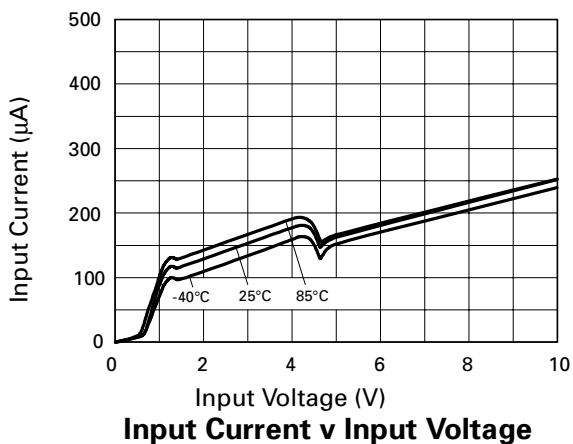

ZSH560

TIMING DIAGRAM

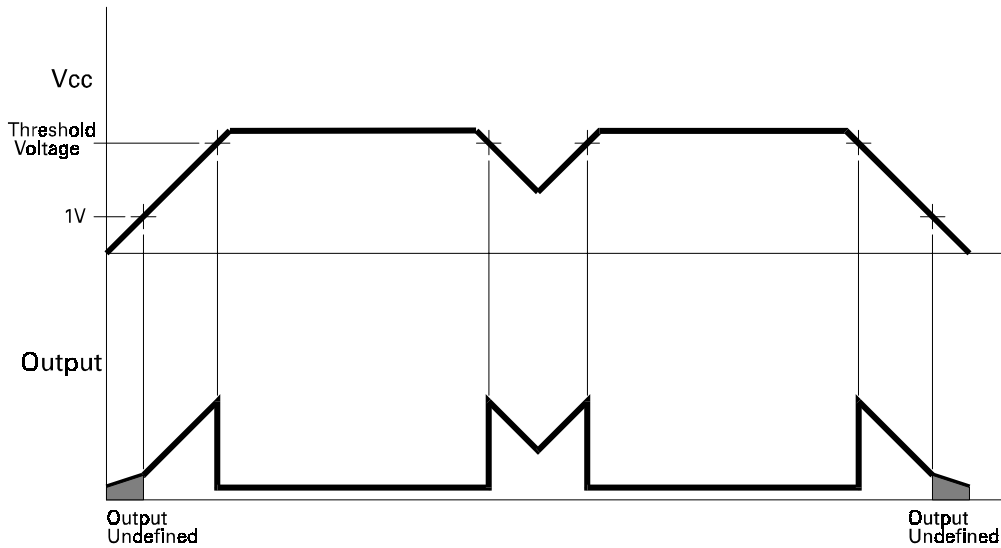

APPLICATION CIRCUIT

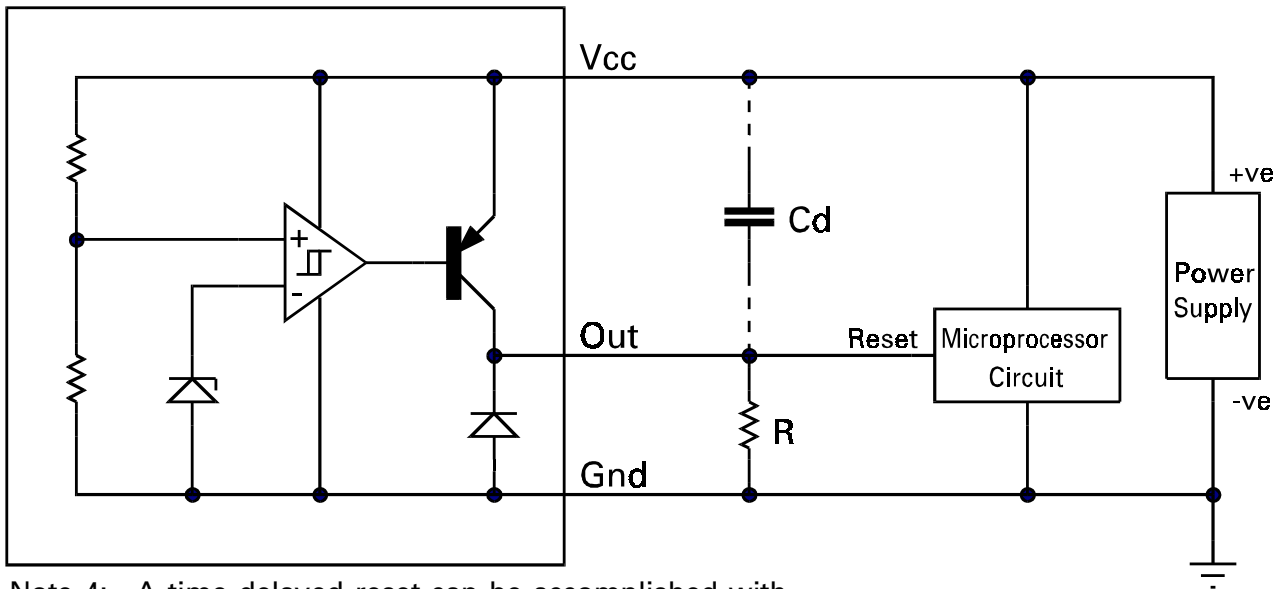

Note 4: A time delayed reset can be accomplished with the additional Cd.

$$T_{DY} = RCd \left[\ln \left(\frac{1}{\frac{V_{TH}}{V_{in}}} \right) - \ln \left(\frac{1}{1 - \frac{V_{SAT}}{V_{in}}} \right) \right]$$

T_{DY} =Time (Seconds)

V_{TH} =Microprocessor Reset Threshold (ground referenced)

V_{SAT} =Output Saturation Voltage (from Output Saturation Voltage characteristic)

V_{in} =Power Supply Voltage

ZSH560

CONNECTION DIAGRAMS

SO8 Package Suffix - N8

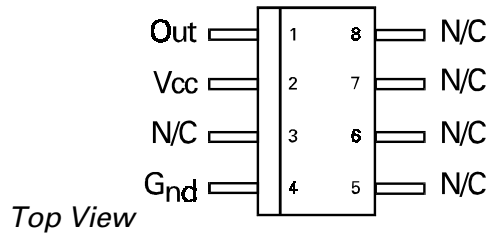

SOT223 Package Suffix - G

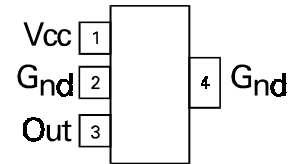

TO92 Package Suffix - C

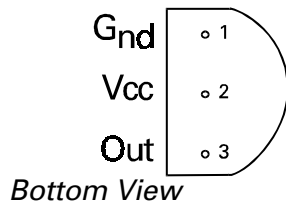

ORDERING INFORMATION

Part No	Package	Partmark
ZSH560C	TO92	ZSH560
ZSH560G	SOT223	ZSH560
ZSH560N8	SO8	ZSH560