



STM1810, STM1811, STM1812, STM1813 STM1815, STM1816, STM1817, STM1818

Low Power Reset Circuit

PRELIMINARY DATA

FEATURES SUMMARY

- PRECISION MONITORING OF 3V, 3.3V, AND 5V SUPPLY VOLTAGES
- FOUR OUTPUT CONFIGURATIONS
 - Push-Pull, Active-High (STM1812,1817)
 - Push-Pull, Active-Low (STM1810,1815)
 - Open Drain, Active-Low (STM1811,1816)
 - Open Drain, Active-Low with Push-Button Detect (STM1813,1818)
- RESET PULSE WIDTH - 100ms (min)
- LOW SUPPLY CURRENT - 4uA (typ)
- GUARANTEED ASSERTION DOWN TO $V_{CC} = 1.0V$ (0°C to 105°C)
- FACTORY-TRIMMED RESET THRESHOLDS OF 2.55V, 2.88V, 3.06V, 4.37V, and 4.62V (typ)
- POWER SUPPLY TRANSIENT IMMUNITY
- PUSH-BUTTON/MANUAL RESET DETECT (STM1813/1818)
- OPERATING TEMPERATURE: -40°C TO 105°C
- ±2.5% RESET THRESHOLD ACCURACY (-40°C TO 105°C)
- AVAILABLE IN THE SOT23-3 PACKAGE
- FULLY COMPATIBLE WITH DS181x AND MXD181x PRODUCTS

Figure 1. Packages

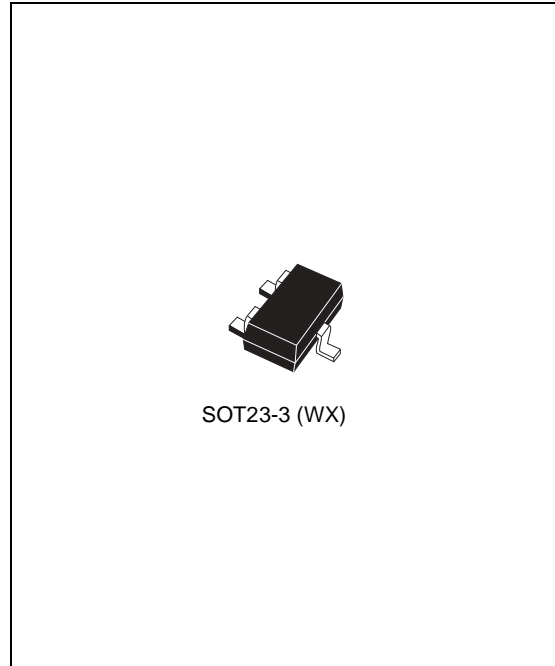

Table 1. Device Options

	5V	3.3V/ 3.0V	Active-Low RESET (Push-Pull)	Active-Low RESET (Open Drain)	Active-High RESET (Push-Pull)	Active-Low RESET (Open Drain, Bi-directional, with MR Detect)
STM1810L/M	✓		✓			
STM1811L/M	✓			✓ ⁽¹⁾		
STM1812L/M	✓				✓	
STM1813L/M	✓					✓
STM1815T/S/R		✓	✓			
STM1816T/S/R		✓		✓ ⁽¹⁾		
STM1817T/S/R		✓			✓	
STM1818T/S/R		✓				✓

Note: 1. Active-low \overline{RST} with internal pull-up resistor

Rev 5

June 2005

1/20

This is preliminary information on a new product now in development or undergoing evaluation. Details are subject to change without notice.

TABLE OF CONTENTS

FEATURES SUMMARY 1

 Figure 1. Packages 1

 Table 1. Device Options 1

SUMMARY DESCRIPTION 4

 Figure 2. Logic Diagram 4

 Table 2. Signal Names 4

 Figure 3. SOT23-3 Connections 4

 Figure 4. Hardware Hookup 5

FUNCTIONAL BLOCK DIAGRAMS 5

 Figure 5. Push-pull Active-Low Output (STM1810/1812/1815/1817) 5

 Figure 6. Open Drain, Active-Low Output (STM1811/1816) 5

 Figure 7. Open Drain, Active-Low Output (Bi-directional, Manual Reset Detect, STM1813/1818) . . 5

PIN DESCRIPTIONS 6

 Table 3. STM1810/STM1815 6

 Table 4. STM1811/STM1816 6

 Table 5. STM1812/STM1817 6

 Table 6. STM1813/STM1818 6

OPERATION 7

Reset Output 7

Push-Button Detect Reset (STM1813/1818) 7

Interfacing to Bidirectional Microcontrollers (MCU's) 7

Negative Going V_{CC} Transients 7

Valid \overline{RST} Output Down to V_{CC} = 0V 7

 Figure 8. Reset Timing Diagram 7

 Figure 9. Push-Button Manual Reset with \overline{MR} Detect (STM1813/1818) 8

 Figure 10. Manual Reset Timing Diagram, Switch Bounce/Debounce (STM1813/1818) 8

 Figure 11. Interfacing MCUs with Bi-Directional Reset Pins (\overline{RST} , Open Drain, STM1811/1816) . . 8

 Figure 12. Valid Reset (\overline{RST}) Output Down to V_{CC} = 0V (Push-pull) 9

 Figure 13. Valid Reset (RST) Output Down to V_{CC} = 0V (Push-pull) 9

TYPICAL OPERATING CHARACTERISTICS 10

 Figure 14. Supply Current vs. Temperature (no load) 10

 Figure 15. Normalized Reset Time-out Period (t_{rec}) vs. Temperature - V_{OD} = V_{TH} - V_{CC} 10

 Figure 16. V_{CC}-to-Reset Output Delay vs. Temperature - V_{OD} = V_{TH} - V_{CC} 11

 Figure 17. Voltage Output Low vs. I_{SINK} 11

 Figure 18. Voltage Output High vs. I_{SOURCE} 12

 Figure 19. Normalized Reset Threshold vs. Temperature 12

 Figure 20. Max Transient Duration NOT Causing Reset Pulse vs. Reset Threshold Overdrive . . 13

MAXIMUM RATING	14
Table 7. Absolute Maximum Ratings	14
DC AND AC PARAMETERS	14
Table 8. Operating and AC Measurement Conditions	14
Figure 21.AC Testing Input/Output Waveforms	14
Table 9. DC and AC Characteristics	15
PACKAGE MECHANICAL	16
Figure 22.SOT23-3 – 3-lead Small Outline Transistor Package Outline	16
Table 10. SOT23-3 – 3-lead Small Outline Transistor Package Mechanical Data	16
PART NUMBERING	17
Table 11. Ordering Information Scheme	17
Table 12. Marking Description	18
REVISION HISTORY	19
Table 13. Document Revision History	19

SUMMARY DESCRIPTION

STM181x devices are low power reset devices used to monitor power supplies for microcontrollers. They perform a single function: asserting a reset signal whenever V_{CC} supply voltage drops below a preset value and keeping it asserted until V_{CC} has risen above the preset threshold for a minimum period of time (t_{rec}). They provide excellent circuit reliability without additional external components when used with +3.0V/+3.3V (STM1815–STM1818), and +5V (STM1810–STM1813) power supply systems.

A precision voltage reference and comparator monitors the V_{CC} input for an out-of-tolerance condition. When an invalid V_{CC} condition occurs, the reset output (\overline{RST}) is forced low (or high in the case of RST) and remains asserted for t_{rec} after V_{CC} rises above the reset threshold. The STM1813/1818 also keep reset asserted for t_{rec} after the output is momentarily pulled to ground by an external push-button switch.

The STM1812 and STM1817 have an active-high, push-pull output. The STM1810 and STM1815 (push-pull) and STM1811, STM1813, STM1816,

and STM1818 (open drain) have an active-low \overline{RST} output. The open drain devices (STM1811/STM1813/STM1816/STM1818) also have an internal pull-up resistor to V_{CC} . The STM1813 and STM1818 feature a debounced manual reset feature that asserts a reset if the \overline{RST} pin is pulled low for more than 1.5 μ s. When used to initiate manual reset, \overline{RST} debounces signals from devices such as mechanical switches. For devices with this feature, the release of the external switch triggers the reset period.

The STM181x devices are guaranteed to output the correct logic state for V_{CC} down to 1.0V (0°C to +105°C). They also provide a reset comparator designed to ignore fast transients on V_{CC} .

Reset thresholds are available between +2.55V and +4.62V. These small, low power devices are ideal for use in portable equipment. All are available in the space-saving 3-pin SOT23 package, and are specified from –40°C to +105°C. Figure 4., page 5 shows a typical hardware hookup for STM181x devices to a Microcontroller.

Figure 2. Logic Diagram

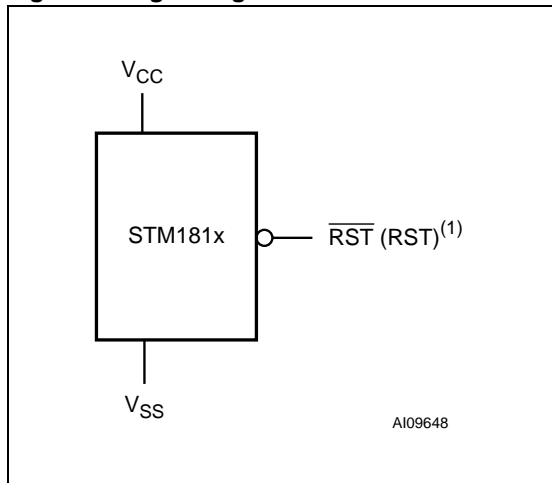

Note: 1. For STM1812, STM1817

Table 2. Signal Names

V_{SS}	Ground
\overline{RST}	Active-low Reset Output
RST ⁽¹⁾	Active-high Reset Output
V_{CC}	Supply Voltage and Input for Reset Threshold Monitor

Note: 1. For STM1812, STM1817

Figure 3. SOT23-3 Connections

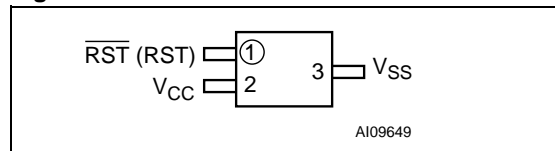

Note: RST for STM1812 and STM1817

Figure 4. Hardware Hookup

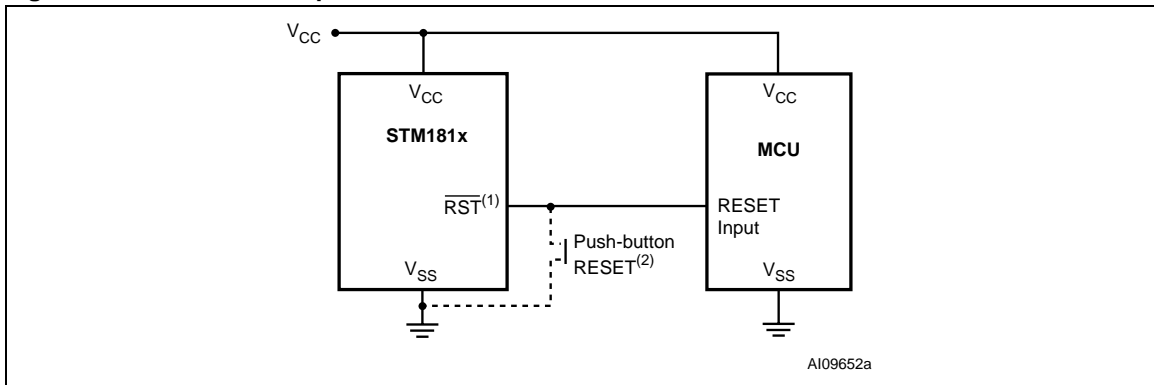

Note: 1. RST for STM1812 and STM1817 (see Table 1., Device Options)
 2. Only valid for STM1813 and STM1818.

FUNCTIONAL BLOCK DIAGRAMS

Figure 5. Push-pull Active-Low Output (STM1810/1812/1815/1817)

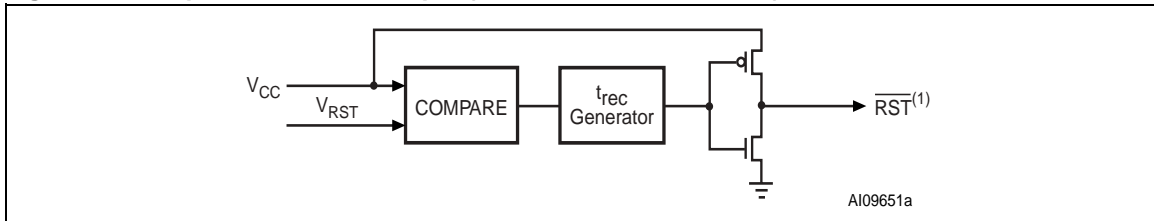

Note: 1. RST for STM1812 and STM1817.

Figure 6. Open Drain, Active-Low Output (STM1811/1816)

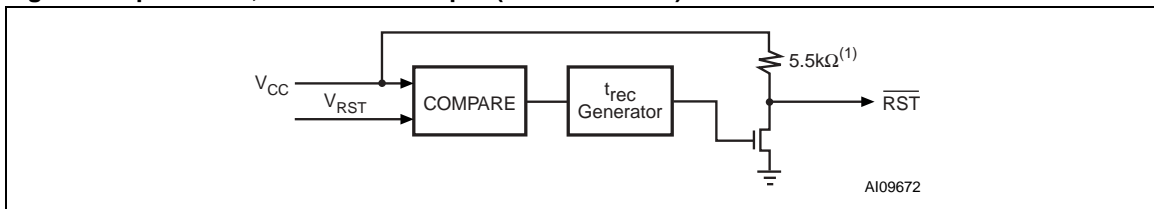

Note: 1. 5.5kΩ internal pull-up resistor

Figure 7. Open Drain, Active-Low Output (Bi-directional, Manual Reset Detect, STM1813/1818)

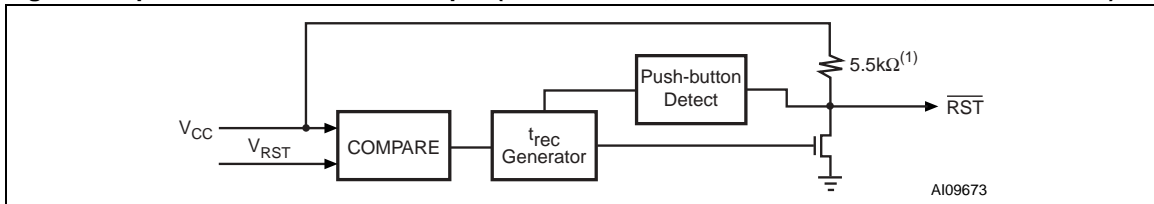

Note: 1. 5.5kΩ internal pull-up resistor

PIN DESCRIPTIONS

See [Figure 2., Logic Diagram](#) and [Table 2., Signal Names](#) for a brief overview of the signals connected to this device.

Active-Low \overline{RST} Output (Push-pull). Pulses low when V_{CC} drops below V_{RST} , and stays low as long as V_{CC} is below the reset threshold. It remains low for t_{rec} after V_{CC} rises above the reset threshold.

Active-Low \overline{RST} Output (Open Drain). Pulses low when V_{CC} drops below V_{RST} , and stays low as long as V_{CC} is below the reset threshold. It remains low for t_{rec} after V_{CC} rises above the reset threshold. \overline{RST} output has an internal 5.5k Ω pull-up resistor.

Active-high RST Output (Push-pull). Pulses high when V_{CC} drops below V_{RST} , and stays high as long as V_{CC} is below the reset threshold. It remains high for t_{rec} after V_{CC} rises above the reset threshold.

Active-Low \overline{RST} Output (Open Drain with internal 5.5k Ω pull-up) with Manual Reset Detect.

Pulses low when V_{CC} drops below V_{RST} , or \overline{RST} is externally pulled low for at least 1.5 μ s. It remains low for t_{PBRST} after V_{CC} rises above the reset threshold, or after the external manual reset is released (see [Figure 10., page 8](#)). \overline{RST} output has an internal 5.5k Ω pull-up resistor.

V_{CC} . Supply voltage and input for V_{RST} comparator.

V_{SS} . Ground, is the reference for the power supply. It must be connected to the system ground.

Table 3. STM1810/STM1815

Pin	Name	Function
1	\overline{RST}	Active-low Reset Output (Push-pull)
2	V_{CC}	Supply Voltage and Input for Reset Threshold Monitor
3	V_{SS}	Ground

Table 4. STM1811/STM1816

Pin	Name	Function
1	\overline{RST}	Active-low Reset Output (Open Drain, with internal 5.5k Ω pull-up resistor)
2	V_{CC}	Supply Voltage and Input for Reset Threshold Monitor
3	V_{SS}	Ground

Table 5. STM1812/STM1817

Pin	Name	Function
1	RST	Active-high Reset Output (Push-pull)
2	V_{CC}	Supply Voltage and Input for Reset Threshold Monitor
3	V_{SS}	Ground

Table 6. STM1813/STM1818

Pin	Name	Function
1	\overline{RST}	Active-low Reset Output (Open Drain, with internal 5.5k Ω pull-up) with Push-Button/Manual Reset Detect
2	V_{CC}	Supply Voltage and Input for Reset Threshold Monitor
3	V_{SS}	Ground

OPERATION

Reset Output

The STM181x asserts a reset signal to the Microcontroller (MCU) whenever V_{CC} goes below the reset threshold (V_{RST}), and is guaranteed valid down to $V_{CC} = 1.0V$ (0° to $105^\circ C$). A microcontroller's (MCU) reset input starts the MCU in a known state. The STM1810 - STM1813/ STM1815 - STM1818 Low Power Reset circuits assert reset to prevent code-execution errors during power-up, power-down, and brownout conditions (Figure 8., page 7).

During power-up, once V_{CC} exceeds the reset threshold an internal timer keeps \overline{RST} low for the reset time-out period, t_{rec} . After this interval, \overline{RST} returns high.

If V_{CC} drops below the reset threshold, \overline{RST} goes low. Each time \overline{RST} is asserted, it stays low for at least the reset time-out period. Any time V_{CC} goes below the reset threshold, the internal timer clears. The reset timer starts when V_{CC} returns above the reset threshold. Reset t_{rec} is also triggered by an externally initiated rising edge on the \overline{RST} pin (STM1813/STM1818), following a low signal of $1.5\mu s$ minimum duration.

Push-Button Detect Reset (STM1813/1818)

Many systems require push-button reset capability (Figure 9., page 8), allowing the user or external logic circuitry to initiate reset. On the STM1813/STM1818, a logic low on \overline{RST} held for greater than $1.5\mu s$ asserts a reset. \overline{RST} deasserts following a 100ms minimum reset time-out delay (t_{rec}). A manual reset input shorter than $1.5\mu s$ may release \overline{RST} without the 100ms minimum reset time-out delay. To facilitate use with mechanical switches, the STM1813/STM1818 contain internal debounce circuitry. A debounced waveform is shown in Figure 10., page 8 The \overline{RST} output has an internal $5.5k\Omega$ pull-up resistor.

Interfacing to Bidirectional Microcontrollers (MCU's)

As the \overline{RST} output on the STM1811/STM1816 is open drain, these devices interface easily with MCU's that have bidirectional reset pins. Connect-

ing the μP supervisor's reset (\overline{RST}) output directly to the microcontroller's reset (\overline{RST}) pin allows either device to assert reset (Figure 11., page 8). No external pull-up resistor is required, as it is within the STM1811/STM1816.

Negative Going V_{CC} Transients

The STM181x are relatively immune to negative-going V_{CC} transients (glitches). Figure 20., page 13 shows typical transient duration versus reset comparator overdrive (for which the STM181x will NOT generate a reset pulse). The graph was generated using a negative pulse applied to V_{CC} , starting at $0.5V$ above the actual reset threshold and ending below it by the magnitude indicated (comparator overdrive). The graph indicates the maximum pulse width a negative V_{CC} transient can have without causing a reset pulse. As the magnitude of the transient increases (further below the threshold), the maximum allowable pulse width decreases. Any combination of duration and overdrive which lies under the curve will NOT generate a reset signal. Typically, a V_{CC} transient that goes $100mV$ below the reset threshold and lasts $20\mu s$ or less will not cause a reset pulse. A $0.1\mu F$ bypass capacitor mounted as close as possible to the V_{CC} pin provides additional transient immunity.

Valid \overline{RST} Output Down to $V_{CC} = 0V$

When V_{CC} falls below $1V$, the \overline{RST} output no longer sinks current, but becomes an open circuit. In most systems this is not a problem, as most MCUs do not operate below $1V$. However, in applications where \overline{RST} output must be valid down to $0V$, a pull-down resistor may be added to hold the \overline{RST} output low (see Figure 12., page 9). This resistor must be large enough to not load the \overline{RST} output, and still be small enough to pull the output to ground. A $100k\Omega$ resistor is recommended.

Note: The same situation applies for the active-high RST of the STM1810/1812. A $100k\Omega$ pull-up resistor to V_{CC} should be used if RST must remain valid for $V_{CC} < 1.0V$.

Figure 8. Reset Timing Diagram

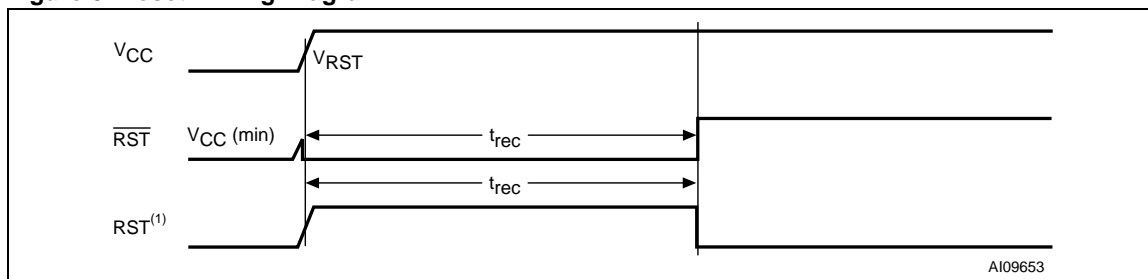

Note: 1. \overline{RST} for STM1812 and STM1817

STM1810/1811/1812/1813/1815/1816/1817/1818

Figure 9. Push-Button Manual Reset with $\overline{\text{MR}}$ Detect (STM1813/1818)

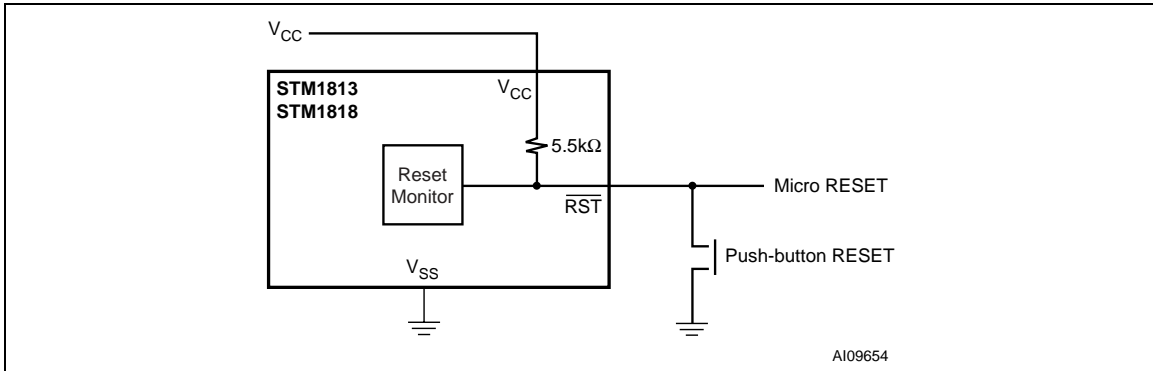

Figure 10. Manual Reset Timing Diagram, Switch Bounce/Debounce (STM1813/1818)

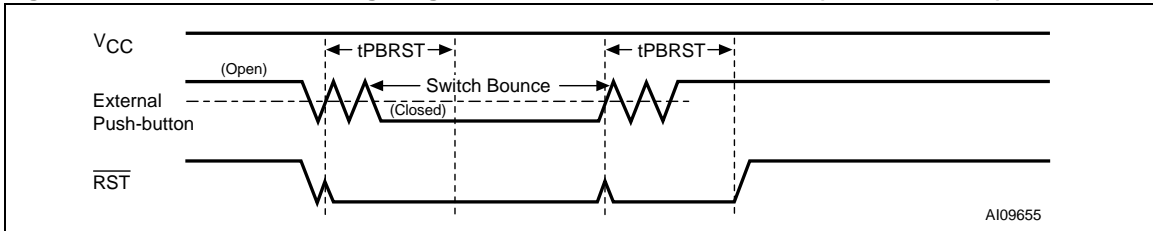

Figure 11. Interfacing MCUs with Bi-Directional Reset Pins ($\overline{\text{RST}}$, Open Drain, STM1811/1816)

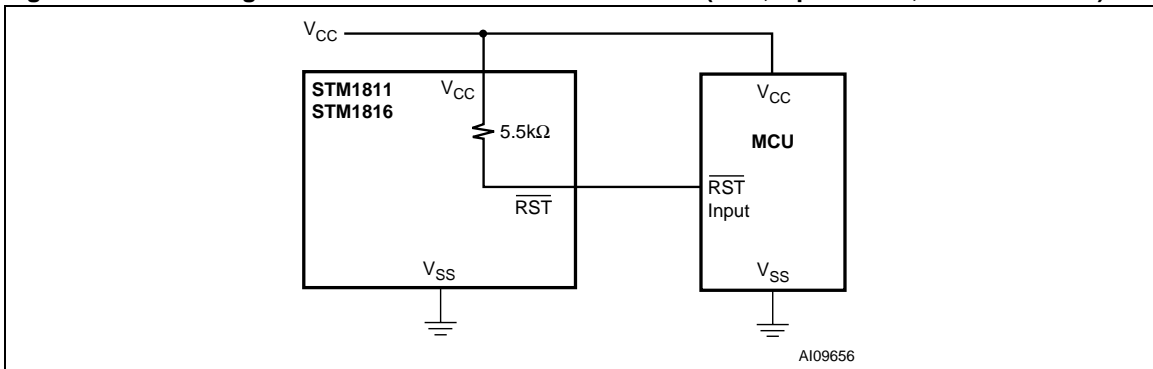
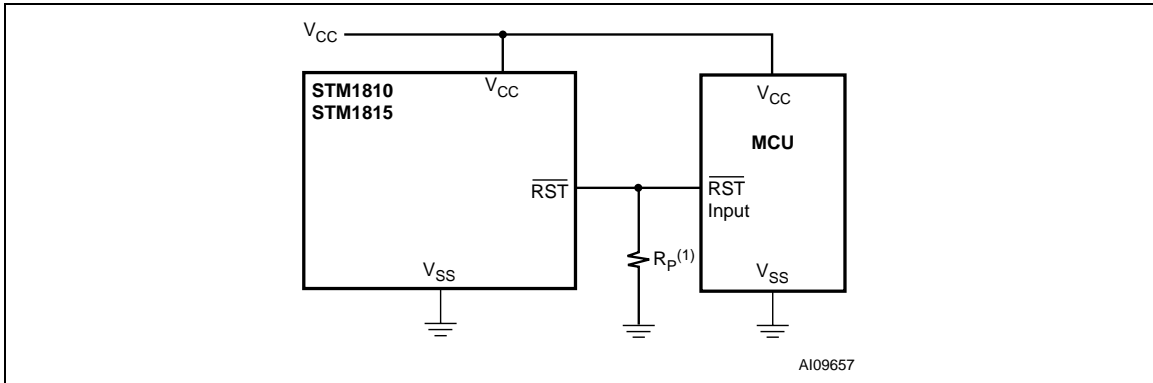
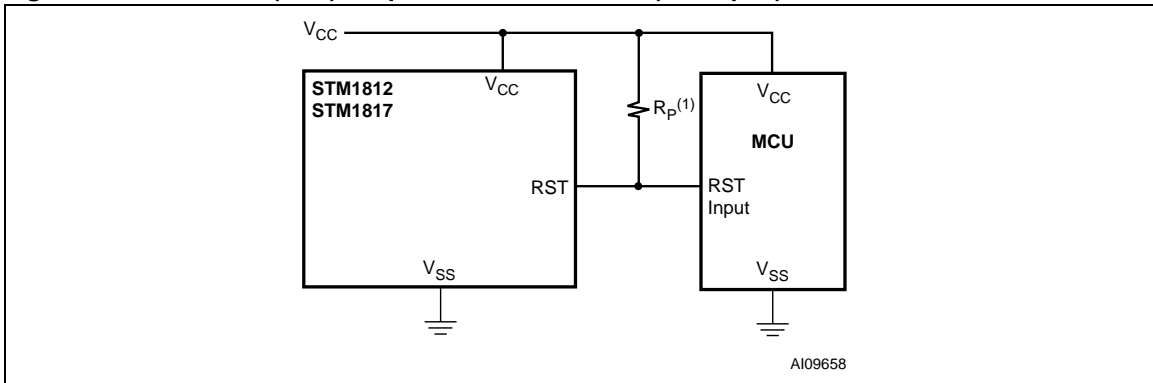

Figure 12. Valid Reset ($\overline{\text{RST}}$) Output Down to $V_{\text{CC}} = 0\text{V}$ (Push-pull)



Note: 1. ~100 k Ω resistor recommended.

Figure 13. Valid Reset (RST) Output Down to $V_{\text{CC}} = 0\text{V}$ (Push-pull)



Note: 1. ~100 k Ω resistor recommended.

TYPICAL OPERATING CHARACTERISTICS

Note: Typical values are at $T_A = 25^\circ\text{C}$.

Figure 14. Supply Current vs. Temperature (no load)

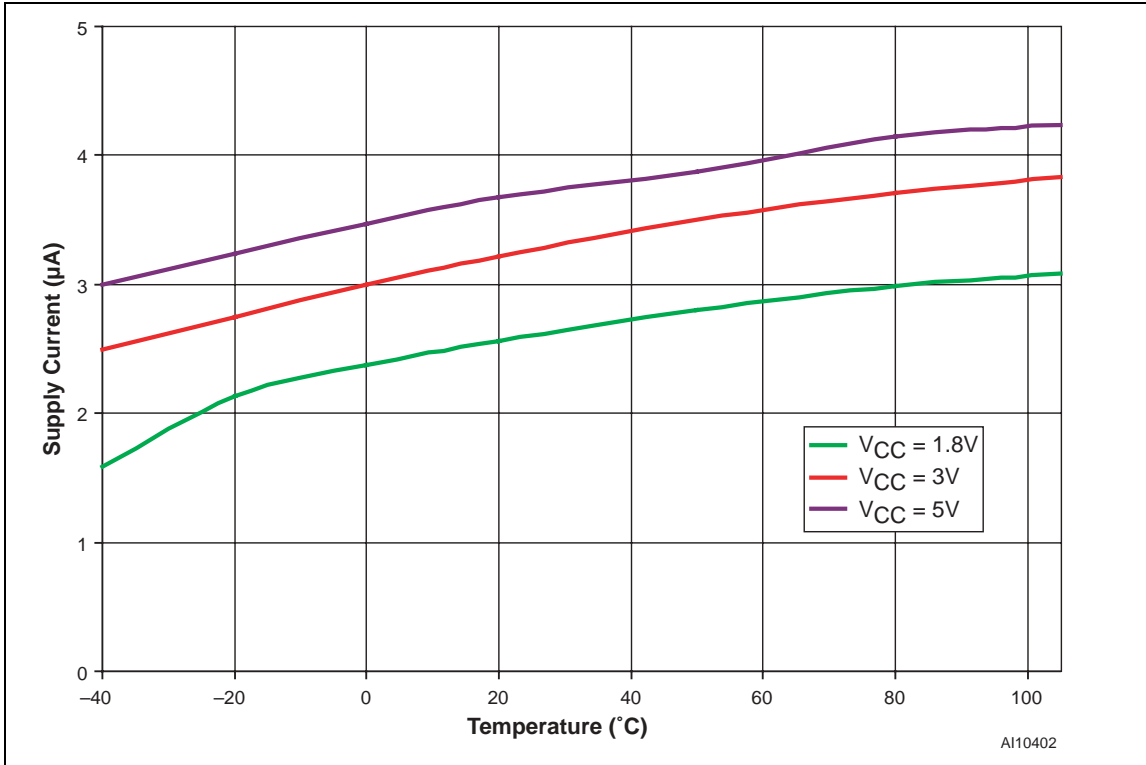

Figure 15. Normalized Reset Time-out Period (t_{rec}) vs. Temperature - $V_{OD} = V_{TH} - V_{CC}$

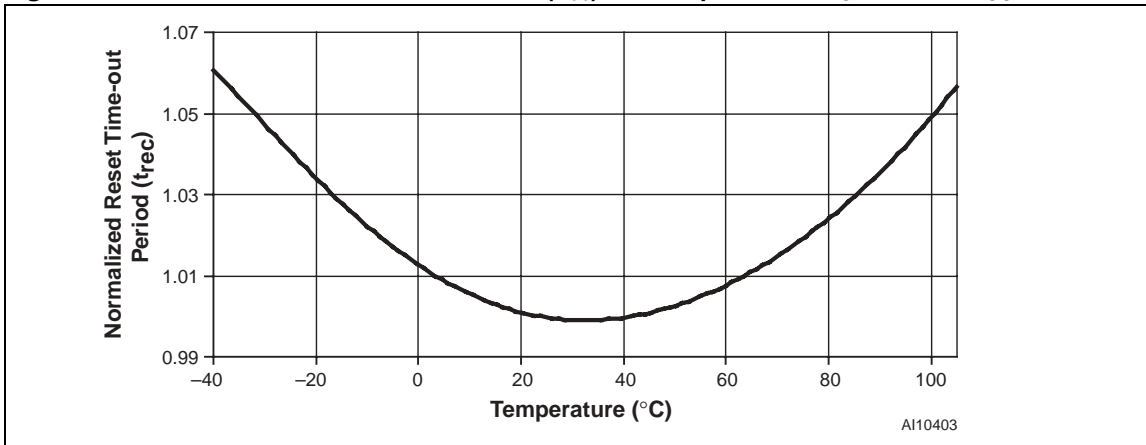

Figure 16. V_{CC} -to-Reset Output Delay vs. Temperature - $V_{OD} = V_{TH} - V_{CC}$

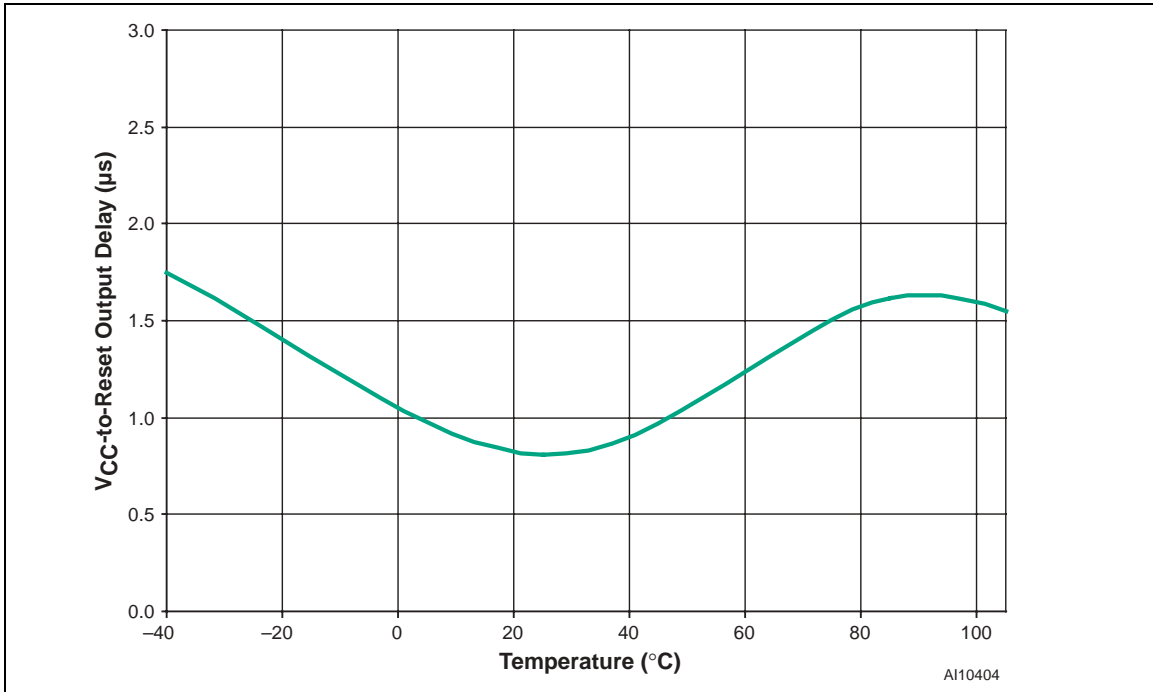

Figure 17. Voltage Output Low vs. I_{SINK}

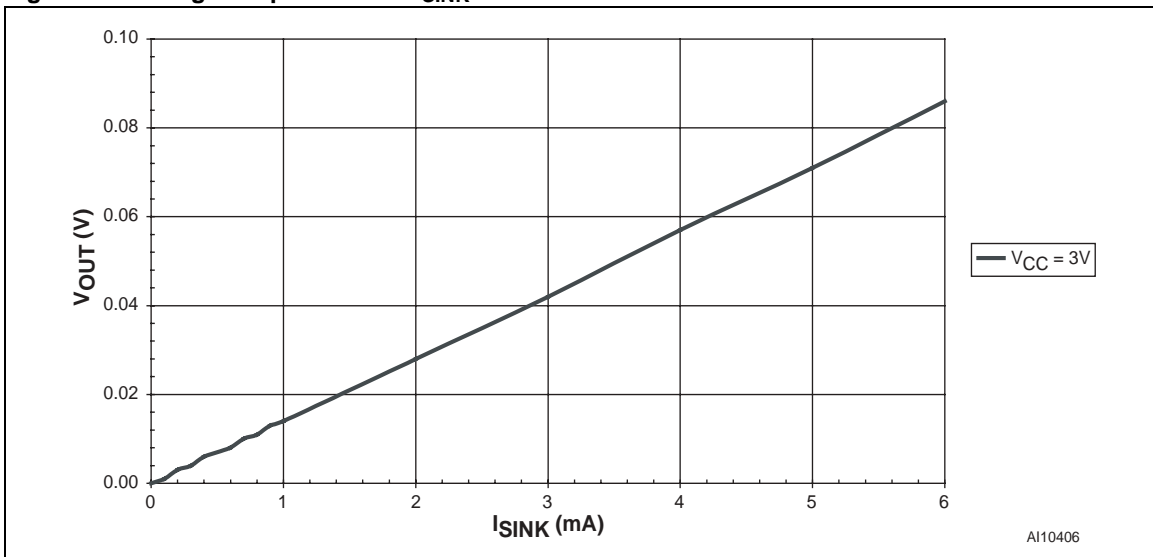

Figure 18. Voltage Output High vs. I_{SOURCE}

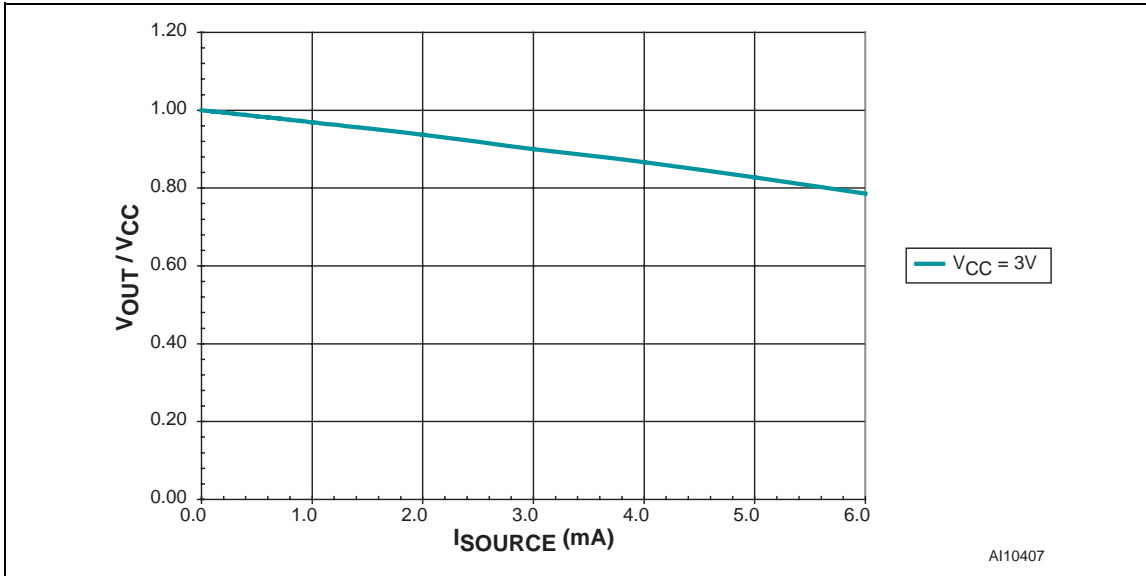

Figure 19. Normalized Reset Threshold vs. Temperature

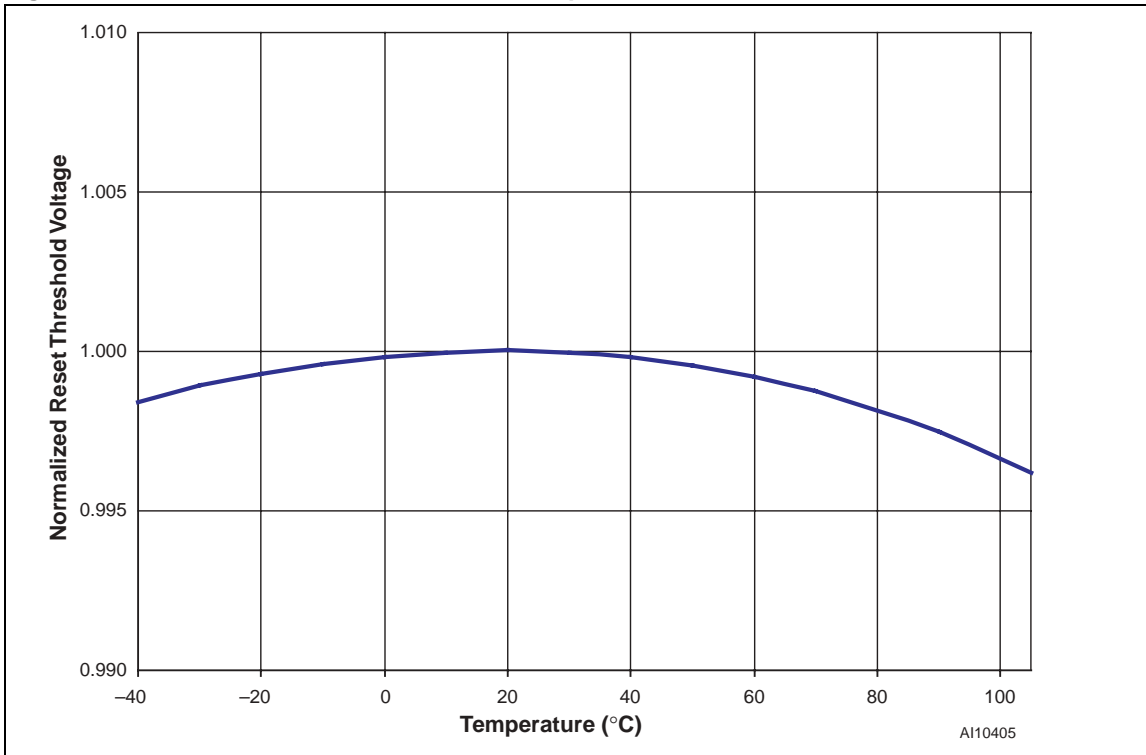
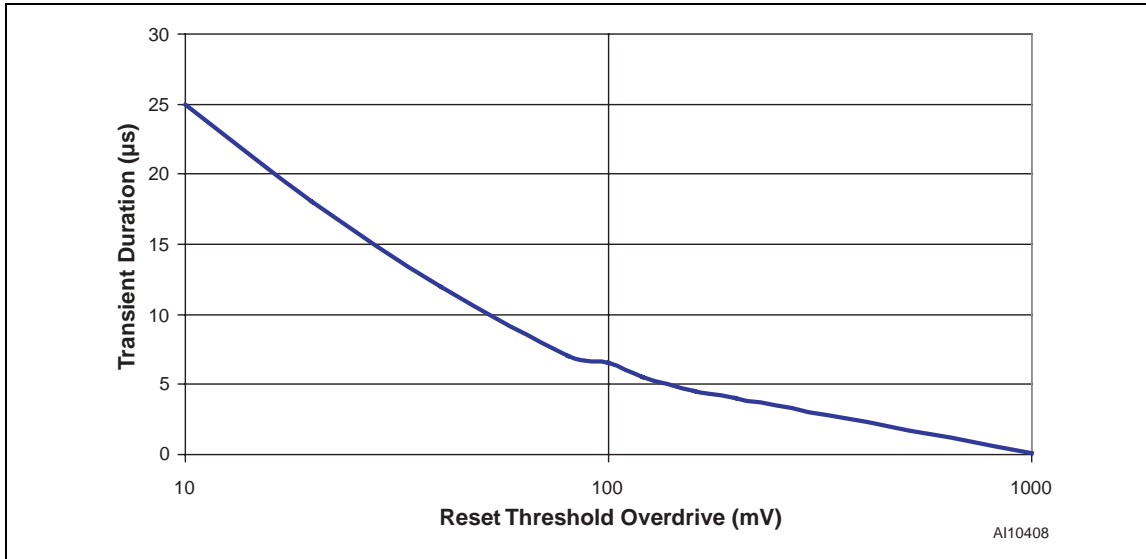

Figure 20. Max Transient Duration NOT Causing Reset Pulse vs. Reset Threshold Overdrive

Note: Reset occurs above the line.

MAXIMUM RATING

Stressing the device above the rating listed in the Absolute Maximum Ratings table may cause permanent damage to the device. These are stress ratings only and operation of the device at these or any other conditions above those indicated in the Operating sections of this specification is not im-

plied. Exposure to Absolute Maximum Rating conditions for extended periods may affect device reliability. Refer also to the STMicroelectronics SURE Program and other relevant quality documents.

Table 7. Absolute Maximum Ratings

Symbol	Parameter	Value	Unit
T _{STG}	Storage Temperature (V _{CC} Off)	-55 to 150	°C
T _{SLD} ⁽¹⁾	Lead Solder Temperature for 10 seconds	260	°C
V _{IO}	Input or Output Voltage	-0.3 to V _{CC} +0.3	V
V _{CC}	Supply Voltage	-0.3 to 7.0	V
I _O	Output Current	20	mA
P _D	Power Dissipation	320	mW

Note: 1. Reflow at peak temperature of 255°C to 260°C for < 30 seconds (total thermal budget not to exceed 180°C for between 90 to 150 seconds).

DC AND AC PARAMETERS

This section summarizes the operating measurement conditions, and the DC and AC characteristics of the device. The parameters in the DC and AC characteristics Tables that follow, are derived from tests performed under the Measurement

Conditions summarized in Table 8, Operating and AC Measurement Conditions. Designers should check that the operating conditions in their circuit match the operating conditions when relying on the quoted parameters.

Table 8. Operating and AC Measurement Conditions

Parameter	STM1810 - 1818	Unit
V _{CC} Supply Voltage	1.0 to 5.5	V
Ambient Operating Temperature (T _A)	-40 to 105	°C
Input Rise and Fall Times	≤ 5	ns
Input Pulse Voltages	0.2 to 0.8V _{CC}	V
Input and Output Timing Ref. Voltages	0.3 to 0.7V _{CC}	V

Figure 21. AC Testing Input/Output Waveforms

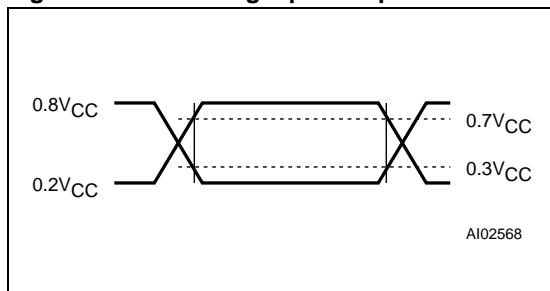

Table 9. DC and AC Characteristics

Sym	Alternative	Description	Test Condition ⁽¹⁾	Min	Typ	Max	Unit			
V _{CC}		Operating Voltage	T _A = 0 to +105°C	1.0		5.5	V			
			T _A = -40 to +105°C	1.2		5.5	V			
I _{CC}		V _{CC} Supply Current	V _{CC} = 3.6V, No load		4	10	μA			
			V _{CC} = 5.5V, No load		9	16	μA			
V _{IH}		Input High Voltage	STM1813/1818 only	0.7V _{CC}			V			
V _{IL}		Input Low Voltage	STM1813/1818 only			0.4	V			
V _{OH}		Output High Voltage	0 < I _{OH} < 500μA	V _{CC} - 0.5	V _{CC} - 0.1		V			
I _{OH}		R _{ST} Output Source Current	V _{CC} ≥ V _{RST} (max), Reset not asserted (STM1810/STM1815)		350		μA			
		R _{ST} Output Source Current	V _{CC} ≤ V _{RST} (min), Reset asserted (STM1812/STM1817)		350		μA			
I _{OL}		R _{ST} Output Sink Current	V _{CC} ≥ 2.7V, Reset asserted, V _{OUT} = 0.4V (STM1810/1811/1813/1815/1816/1818)	10			mA			
		R _{ST} Output Sink Current	V _{CC} ≥ 2.7V, Reset not asserted, V _{OUT} = 0.4V, (STM1812/1817)	10			mA			
C _{OUT}		Output Capacitance ⁽²⁾				10	pF			
Reset Thresholds										
V _{RST}		Reset Threshold	STM181xL	25°C		4.62	V			
				-40 to 105°C	4.50		4.75	V		
			STM181xM	25°C		4.37	V			
				-40 to 105°C	4.25		4.49	V		
			STM181xT	25°C		3.06	V			
				-40 to 105°C	2.98		3.15	V		
			STM181xS	25°C		2.88	V			
				-40 to 105°C	2.80		2.97	V		
			STM181xR	25°C		2.55	V			
				-40 to 105°C	2.47		2.64	V		
			t _{RD}		V _{CC} to R _{ST} Delay	V _{CC} = (V _{TH} + 100mV) falling to (V _{TH} - 200mV)		2	5	μs
				t _{rec}	R _{ST} Pulse Width	V _{CC} Rising	100	150	200	ms
Push-Button Reset Detect (STM1813, STM1818)										
t _{PB}		Push-button Detect to R _{ST}	STM1813/1818	1.5			μs			
t _{PBRST}		Push-button R _{ST} Time-out	From Rising Edge	100	150	200	ms			
		Internal Pull-up Resistance	STM1811/1816	3.5	5.5	7.5	kΩ			
			STM1813/1818	3.1	5.5	7.5	kΩ			

Note: 1. Valid for Ambient Operating Temperature: T_A = -40 to 105°C; V_{CC} = 1.2V to 5.5V (except where noted).
 2. The STM1811/1813/1816/1818 have an internal pull-up resistor which may sink 1mA of current.

PACKAGE MECHANICAL

Figure 22. SOT23-3 – 3-lead Small Outline Transistor Package Outline

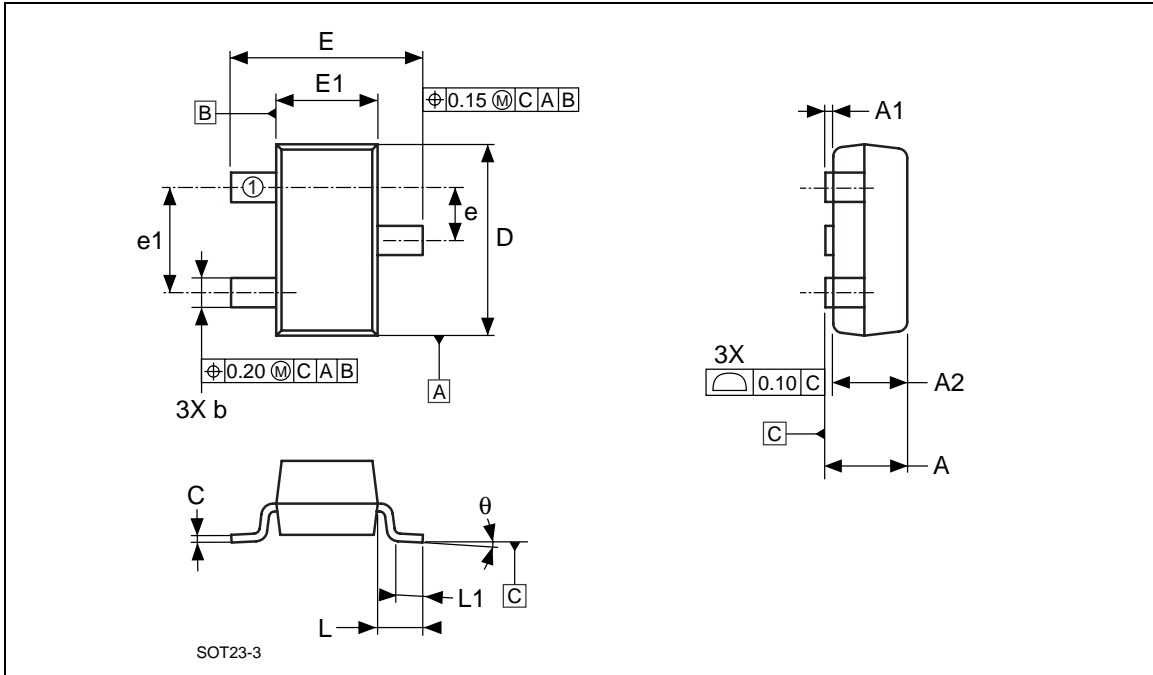

Note: Drawing is not to scale.

Table 10. SOT23-3 – 3-lead Small Outline Transistor Package Mechanical Data

Symbol	mm			inches		
	Typ	Min	Max	Typ	Min	Max
A		0.89	1.12		0.035	0.044
A1		0.01	0.10		0.001	0.004
A2		0.88	1.02		0.035	0.042
b		0.30	0.50		0.012	0.020
C		0.08	0.20		0.003	0.008
D		2.80	3.04		0.110	0.120
E		2.10	2.64		0.083	0.104
E1		1.20	1.40		0.047	0.055
e		0.89	1.03		0.035	0.041
e1		1.78	2.05		0.070	0.081
L	0.54			0.021		
L1		0.40	0.60		0.016	0.024
θ		0°	8°		0°	8°
N		3			3	

PART NUMBERING

Table 11. Ordering Information Scheme

Example:	STM1810	L	WX	7	F
Device Type					
STM181x					
Reset Threshold Voltage					
STM1810 - 1813:					
L = $V_{RST} = 4.50V$ to $4.75V$ (4.62 typ)					
M = $V_{RST} = 4.25V$ to $4.49V$ (4.37 typ)					
STM1815 - 1818:					
T = $V_{RST} = 2.98V$ to $3.15V$ (3.06 typ)					
S = $V_{RST} = 2.80V$ to $2.97V$ (2.88 typ)					
R = $V_{RST} = 2.47V$ to $2.64V$ (2.55 typ)					
Package					
WX = SOT23-3					
Temperature Range					
7 = -40 to $105^{\circ}C$					
Shipping Method					
F = Pb-Free Package, Tape & Reel					

Note: 1. Contact the local ST sales office for availability.

For other options, or for more information on any aspect of this device, please contact the ST Sales Office nearest you.

STM1810/1811/1812/1813/1815/1816/1817/1818**Table 12. Marking Description**

Part Number	Reset Threshold	Output	Topside Marking
STM1810L	4.62V	Push-Pull \overline{RST}	
STM1810M	4.37V	Push-Pull \overline{RST}	
STM1811L	4.62V	Open Drain \overline{RST}	
STM1811M	4.37V	Open Drain \overline{RST}	
STM1812L	4.62V	Push-Pull RST	
STM1812M	4.37V	Push-Pull RST	
STM1813L	4.62V	Open Drain RST	
STM1813M	4.37V	Open Drain RST	
STM1815T	3.06V	Push-Pull \overline{RST}	
STM1815S	2.88V	Push-Pull \overline{RST}	
STM1815R	2.55V	Push-Pull \overline{RST}	
STM1816T	3.06V	Open Drain \overline{RST}	
STM1816S	2.88V	Open Drain \overline{RST}	
STM1816R	2.55V	Open Drain \overline{RST}	
STM1817T	3.06V	Push-Pull RST	
STM1817S	2.88V	Push-Pull RST	
STM1817R	2.55V	Push-Pull RST	
STM1818T	3.06V	Open Drain RST	
STM1818S	2.88V	Open Drain RST	
STM1818R	2.55V	Open Drain RST	

REVISION HISTORY

Table 13. Document Revision History

Date	Revision	Revision Details
26-Aug-04	1.0	First Issue
05-Oct-04	2.0	Update reset characteristics, add typical graphs, remove SC70 references (Figure 1 , 2 , 4 , 7 , 11 , 12 , 13 , 14 , 15 , 16 , 17 , 18 , 19 , 20 ; Table 9 , 11 , 12)
19-Nov-04	3.0	Update dimensions (Table 10)
07-Dec-04	4.0	Remove some voltage options (Table 1 , 9 , 11 , 12)
29-Jun-05	5	Temperature range change (Figure 14 , 15 , 16 , 19 ; Table 8 , 9 , 11)

Information furnished is believed to be accurate and reliable. However, STMicroelectronics assumes no responsibility for the consequences of use of such information nor for any infringement of patents or other rights of third parties which may result from its use. No license is granted by implication or otherwise under any patent or patent rights of STMicroelectronics. Specifications mentioned in this publication are subject to change without notice. This publication supersedes and replaces all information previously supplied. STMicroelectronics products are not authorized for use as critical components in life support devices or systems without express written approval of STMicroelectronics.

The ST logo is a registered trademark of STMicroelectronics.

All other names are the property of their respective owners

© 2005 STMicroelectronics - All rights reserved

STMicroelectronics group of companies

Australia - Belgium - Brazil - Canada - China - Czech Republic - Finland - France - Germany - Hong Kong - India - Israel - Italy - Japan -
Malaysia - Malta - Morocco - Singapore - Spain - Sweden - Switzerland - United Kingdom - United States of America
www.st.com