



STM1404

3V FIPS-140

Security Supervisor with Battery Switchover

DATA BRIEFING

FEATURES

- STM1404 SUPPORTS FIPS-140 SECURITY LEVEL 4
 - 4 High-Impedance Physical Tamper Inputs
 - Over/Under Operating Voltage Detector
 - Security Alarm ($\overline{\text{SAL}}$) on Tamper Detection
 - Over/Under Operating Temperature Detector
 - Over/Under Temperature Thresholds are Customer-Selectable and Factory-Programmed
- SUPERVISORY FUNCTIONS
 - Automatic Battery Switchover
 - $\overline{\text{RST}}$ Output (Open Drain)
 - Manual (Push-button) Reset Input ($\overline{\text{MR}}$)
 - Power-fail Comparator ($\text{PFI}/\overline{\text{PFO}}$)
- $\overline{\text{Vccsw}}$ (VCC SWITCH OUTPUT)
 - Low When Switched to V_{CC}
 - High When Switched to V_{BAT} (BATT ON Indicator)
- BATTERY LOW VOLTAGE DETECTOR (POWER-UP)

Figure 1. Package

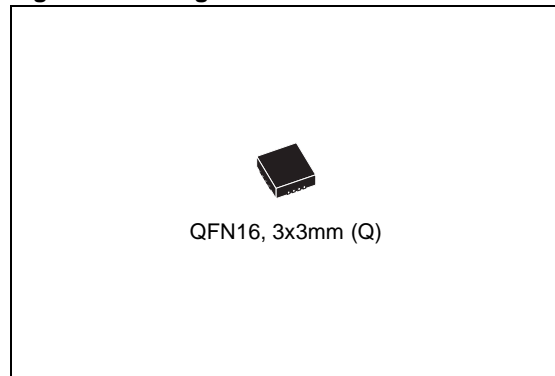

- OPTIONAL V_{REF} (1.237V)
(Available for STM1404A only)
- LOW BATTERY SUPPLY CURRENT (5.3 μA Typ)
- SECURE LOW PROFILE 16-PIN, 3x3mm, QFN PACKAGE
- RoHS COMPLIANCE
Lead-free components compliant with the RoHS directive

Table 1. Device Options

	STM704 Functions ⁽¹⁾	Physical Tamper Inputs	Over/Under Voltage Alarms	Over/Under Temperature Alarms	V_{REF} (1.237V) Option	V_{OUT} Status, During Alarm	$\overline{\text{Vccsw}}$ Status, During Alarm
STM1404A	✓	✓	✓	✓	✓	ON	Normal Mode ⁽²⁾
STM1404B	✓	✓	✓	✓	Note 3	High-Z	High
STM1404C	✓	✓	✓	✓	Note 3	Ground	High

Note: 1. $\overline{\text{SAL}}$, $\overline{\text{RST}}$, $\overline{\text{PFO}}$, and $\overline{\text{BLD}}$ are Open Drain.

2. Normal Mode: Low when V_{OUT} is internally switched to V_{CC} and High when V_{OUT} is internally switched to battery.

3. Pin 9 is the V_{REF} pin for STM1404A. It is the V_{TPU} pin for STM1404B/C.

SUMMARY DESCRIPTION

The STM1404 family of security supervisors are a low power family of intrusion (tamper) detection chips targeted at manufacturers of POS terminals and other systems, to enable them to meet **physical and/or environmental** intrusion monitoring requirements as mandated by various standards, such as Federal Information Processing Standards (FIPS) Pub 140 entitled "Security Requirements for Cryptographic Modules," published by the National Institute of Standards and Technology, U.S. Department of Commerce), EMVCo, ISO, ZKA, and VISA PED.

STM1404 will target the highest security level 4 and include both physical and environmental (voltage and temperature) monitoring.

The STM1404 include Automatic Battery Switchover, \overline{RST} Output (Open Drain), Manual (Push-button) Reset Input (\overline{MR}), Power-fail Comparator (PFI/PFO), Physical and/or Environmental Tamper Detect/Security Alarm, and Battery Low Voltage Detect features.

The STM1404A also offers a V_{REF} (1.237V) as an option on pin 9. On STM1404B/C this pin is V_{TPU} (internally switched V_{CC} or V_{BAT}).

V_{OUT} Pin Modes

The STM1404 is available in three versions, corresponding to three modes of the V_{OUT} pin (Supply Voltage Out), when the \overline{SAL} (Security Alarm) is asserted (active-low) upon tamper detection:

STM1404A. V_{OUT} stays ON (at V_{CC} or V_{BAT}) when \overline{SAL} is driven low (activated).

STM1404B. V_{OUT} is set to High-Z when \overline{SAL} is driven low (activated).

STM1404C. V_{OUT} is driven to Ground when \overline{SAL} is activated (may be used when V_{OUT} is connected directly to the V_{CC} pin of the external SRAM that holds the cryptographic codes).

All variants (see [Table 1., Device Options](#)) are pin-compatible and available in a security-friendly, low profile, 16-pin QFN package.

Figure 2. Logic Diagram

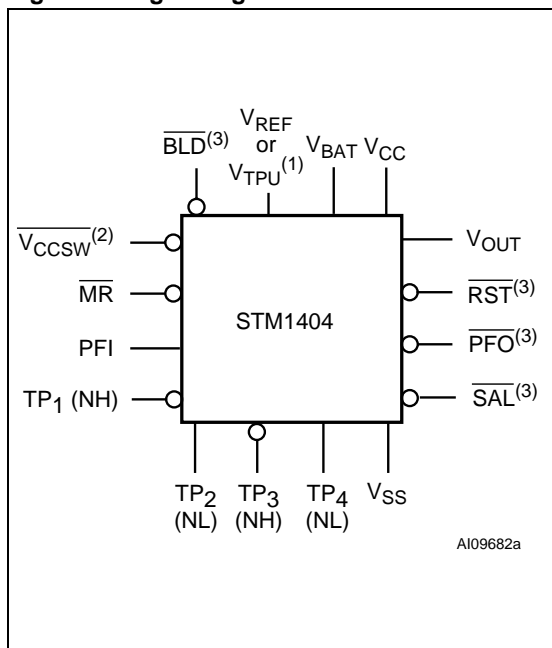

Note: 1. V_{REF} only for STM1404A; V_{TPU} for STM1404B/C.
2. Normal Mode: Low when V_{OUT} is internally switched to V_{CC} and High when V_{OUT} is internally switched to battery.
3. \overline{SAL} , \overline{RST} , \overline{PFO} , and \overline{BLD} are Open Drain.

Table 2. Signal Names

$\overline{V_{CCSW}}^{(1)}$	V_{CC} Switch Output
\overline{MR}	Manual (Push-button) Reset Input
PFI	Power-fail Input
$TP_1 - TP_4$	Independent Physical Tamper Detect Pins 1 through 4
V_{OUT}	Supply Voltage Output
$\overline{RST}^{(2)}$	Active-low Reset Output
$\overline{PFO}^{(2)}$	Power-fail Output
$\overline{SAL}^{(2)}$	Security Alarm Output
$\overline{BLD}^{(2)}$	Battery Low Voltage Detect
$V_{REF}^{(3)}$	1.237V Reference Voltage
$V_{TPU}^{(3)}$	Tamper Pull-up (V_{CC} or V_{BAT})
V_{BAT}	Back-up Supply Voltage
V_{CC}	Supply Voltage
V_{SS}	Ground

Note: See [PIN DESCRIPTIONS](#) of the full datasheet for details.
1. Normal Mode: Low when V_{OUT} is internally switched to V_{CC} and High when V_{OUT} is internally switched to battery.
2. \overline{SAL} , \overline{RST} , \overline{PFO} , and \overline{BLD} are Open Drain.
3. V_{REF} only for STM1404A; V_{TPU} for STM1404B/C.

Figure 3. QFN16 Connections

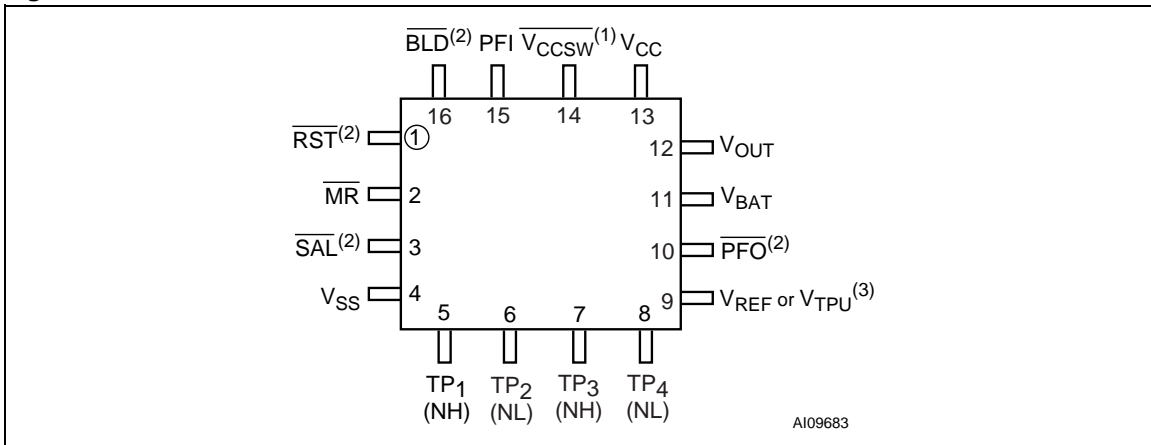

Note: See [PIN DESCRIPTIONS](#) of the full datasheet for details.

1. Normal Mode: Low when V_{OUT} is internally switched to V_{CC} and High when V_{OUT} is internally switched to battery.
2. \overline{SAL} , \overline{RST} , \overline{PFO} , and \overline{BLD} are Open Drain.
3. V_{REF} only for STM1404A; V_{TPU} for STM1404B/C.

Figure 4. Block Diagram

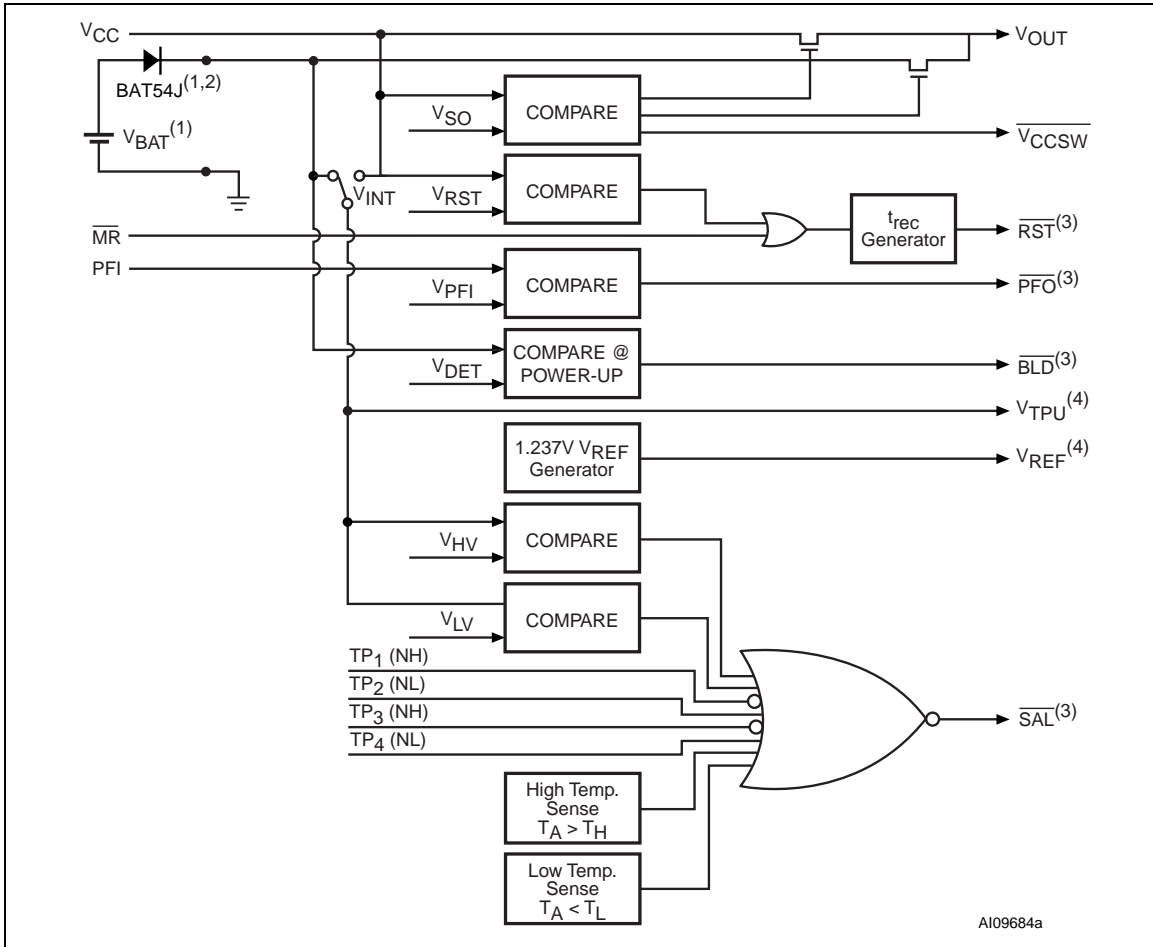

- Note: 1. BAT54J (from STMicroelectronics) recommended.
 2. Required for battery-reverse charging protection.
 3. Open Drain
 4. VREF only for STM1404A; VTPU for STM1404B/C.

TAMPER DETECTION

Physical

There are four (4) high-impedance physical tamper detect input pins, 2 normally set to High (NH) and 2 normally set to Low (NL). Each input is designed with a glitch immunity. These inputs can be connected externally to several types of actuator devices (e.g., switches, wire mesh). A tamper on any one of the four inputs that causes its state to change will trigger the security alarm ($\overline{\text{SAL}}$) and drive it to active-low. Once the tamper condition no longer exists, the $\overline{\text{SAL}}$ will return to its normal High state.

TP_1 and TP_3 are set Normally to High (NH). They are connected externally through a closed switch or a high-impedance resistor to V_{OUT} (in the case of STM1404A or STM1404A) or V_{TPU} (in the case of STM1404B/C). A tamper condition will be detected when the input pin is pulled low. If not used, tie the pin to V_{OUT} or V_{TPU} .

TP_2 and TP_4 are set Normally to Low (NL). They are connected externally through a high-impedance resistor or a closed switch to V_{SS} . A tamper condition will be detected when the input pin is pulled high. If not used, tie the pin to V_{SS} .

Supply Voltage

The internally switched supply voltage, V_{INT} (either V_{CC} input or V_{BAT} input) is continuously monitored. If V_{INT} should exceed the over voltage trip point, V_{HV} (set at 4.2V, typical), or should go below the under voltage trip point, V_{LV} (set at 2.0V, typical). $\overline{\text{SAL}}$ will be driven active-low. Once the tamper condition no longer exists, the $\overline{\text{SAL}}$ pin will return to its normal High state.

Temperature

The STM1404 has a built-in, bandgap-based sensor to monitor the temperature. If a preset (customer-selectable, factory-programmed) over-temperature trip point (T_{H}) or under-temperature trip point (T_{L}) is exceeded, the $\overline{\text{SAL}}$ is asserted low.

When no tamper condition exists, $\overline{\text{SAL}}$ is normally High.

When a tamper is detected, the $\overline{\text{SAL}}$ is activated (driven low), independent of the part type. V_{OUT} can be driven to one of three states, depending on which variant of STM1404 is being used (see [Device Options, page 1](#)):

- ON;
- High-Z; or
- Ground (V_{SS}).

Note: The STM1404 must be initially powered above V_{RST} to enable the tamper detection alarms. For example, if the battery is on while $V_{\text{CC}} = 0\text{V}$, no alarm condition can be detected until V_{CC} rises above V_{RST} (and t_{rec} expires). From this point on, alarms can be detected either on battery or V_{CC} . This is done to avoid false alarms when the device goes from no power to its operational state.

PART NUMBERING

Table 3. Ordering Information Scheme (see Figure 5., page 7 for Marking Information)

Example:	STM1404	A	T	M	D	Q	6	F
Device Type STM1404: Over/Under Temperature Detect								
V_{OUT} Status ($\overline{\text{SAL}}$ = Active-Low) A: V _{OUT} = ON; $\overline{\text{Vccsw}}$ = Normal Mode B: V _{OUT} = High-Z; $\overline{\text{Vccsw}}$ = High C: V _{OUT} = Ground; $\overline{\text{Vccsw}}$ = High								
Reset Threshold Voltage T: V _{RST} = 3.00V to 3.15V S: V _{RST} = 2.85V to 3.00V R: V _{RST} = 2.55V to 2.70V								
Battery Low Voltage Detect Threshold (V_{DET}) M: V _{DET} = 2.3V (Typ) N: V _{DET} = 2.5V (Typ) O: V _{DET} = 3.2V (Typ)								
Under (TL)/Over (TH) Temperature Alarm Thresholds (STM1404 only) B: -25/+80°C H: -35/+80°C C: -25/+85°C I: -35/+85°C D: -25/+95°C J: -35/+95°C								
Package Q = QFN16 (3mm x 3mm)								
Temperature Range 6 = -40 to 85°C								
Shipping Method F = ECOPACK Package, Tape & Reel								

For other options, or for more information on any aspect of this device, please contact the ST Sales Office nearest you.

Figure 5. Topside Marking Information

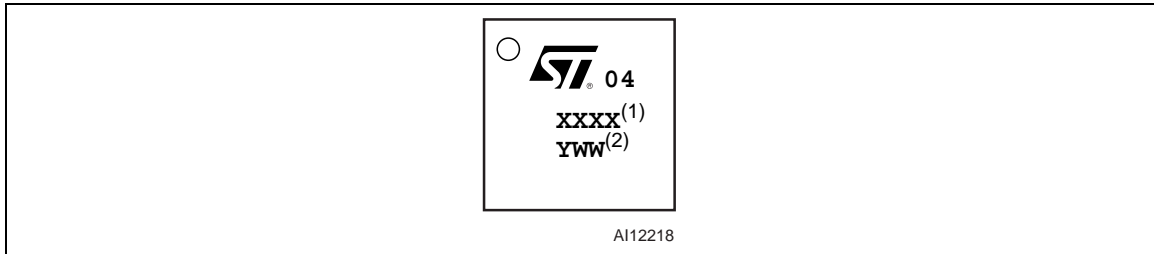

Note: 1. Options codes:

X = A, B, or C (for V_{OUT})

X = T, S, or R (for Reset Threshold)

X = M, N, or O (for Battery Low Voltage Detect Threshold)

X = B, C, D, H, I, or J (for Temperature Alarm Threshold)

2. Traceability Codes

Y = Year

WW = Work Week

REVISION HISTORY**Table 4. Document Revision History**

Date	Version	Description
11-October-04	1.0	First Edition
26-Nov-04	1.1	Corrected footprint dimensions; update characteristics (Figure 2, 3, 4; Table 1, 2)
22-Dec-04	1.2	Update characteristics (Table 3)
03-Feb-05	1.3	Update characteristics
25-Feb-05	1.4	Update temperature trip limits (Table 3)
06-May-05	2.0	v2.0 of DB corresponds to v1.5 of DS
03-Jan-05	3.0	v3.0 of DB corresponds to v2.0 of DS
06-Jan-06	4.0	v4.0 of DB corresponds to v3.0 of DS

Information furnished is believed to be accurate and reliable. However, STMicroelectronics assumes no responsibility for the consequences of use of such information nor for any infringement of patents or other rights of third parties which may result from its use. No license is granted by implication or otherwise under any patent or patent rights of STMicroelectronics. Specifications mentioned in this publication are subject to change without notice. This publication supersedes and replaces all information previously supplied. STMicroelectronics products are not authorized for use as critical components in life support devices or systems without express written approval of STMicroelectronics.

The ST logo is a registered trademark of STMicroelectronics.

All other names are the property of their respective owners

© 2006 STMicroelectronics - All rights reserved

STMicroelectronics group of companies

Australia - Belgium - Brazil - Canada - China - Czech Republic - Finland - France - Germany - Hong Kong - India - Israel - Italy - Japan -
Malaysia - Malta - Morocco - Singapore - Spain - Sweden - Switzerland - United Kingdom - United States of America
www.st.com

