

MN1380 Series

CMOS LSIs for Voltage Detection

Overview

The MN1380 series are elements that monitor the power supply voltage supplied to microcomputers and other LSI systems and issue reset signals for initializing the system after the power is first applied or for preventing runaway operation when the supply voltage fluctuates.

There is a choice of three output types: CMOS output, N-channel open drain output, and inverted CMOS output. There are also three package types: M, TO-92, and a mini type for surface mounting.

Choose the ideal element for your application from the series' wide selection of detection ranks (17 ranks between 2.0 and 4.9 volts), output types, and package types.

Features

- Three-pin element requiring no adjustment
- Wide selection of detection ranks (17 ranks between 2.0 and 4.9 volts)
- Highly precise detection voltage
- Detection voltage with hysteresis characteristic
 $\Delta V_D = 50 \text{ mV}$ for ranks C to K
 $\Delta V_D = 100 \text{ mV}$ for ranks L to U
- Low current consumption: $I_{DD} = 1\mu\text{A}$ (typ.) for $V_{DD} = 5 \text{ V}$
- Low fluctuation in detection voltage with temperature (typ. $1 \text{ mV}/^\circ\text{C}$)
- Wide selection of output types: CMOS output, N-channel open drain output, and inverted CMOS output
- Wide selection of package types: M, TO-92, and a mini type for surface mounting.

Applications

- Battery checkers
- Power outage detectors
- Level discriminators
- Memory backup systems
- Microcomputer reset circuits
- Reset circuits for other electronic circuits

Pin Assignment

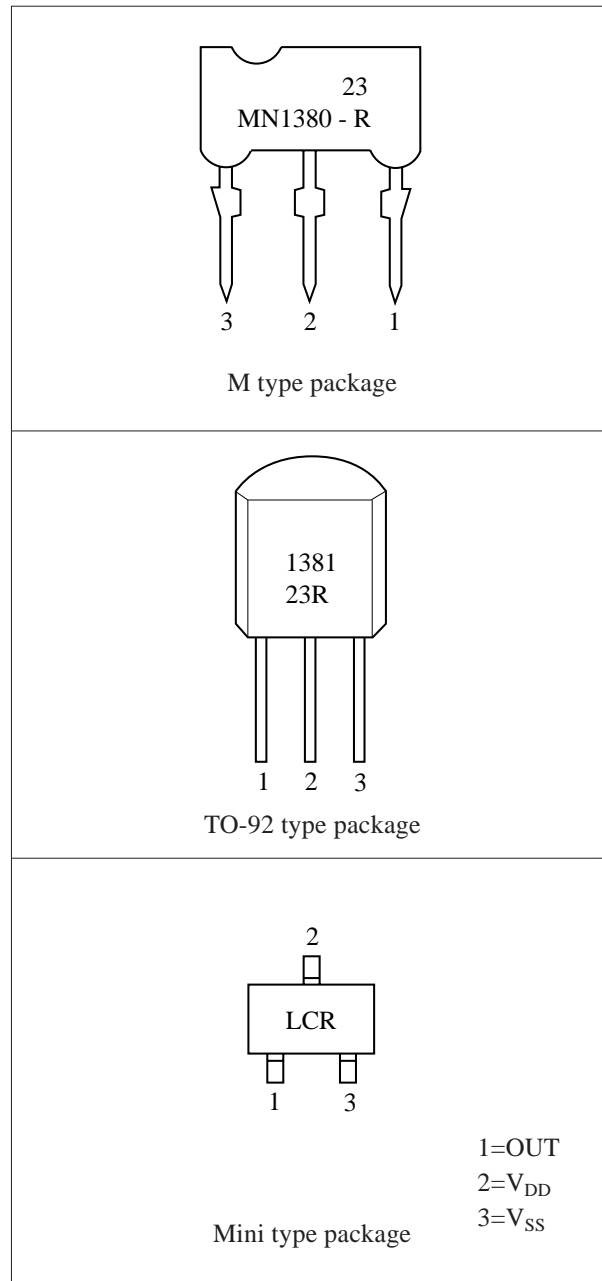

■ MN1380 Series Naming Conventions

The MN1380 series offers a wide selection of detection ranks, output types, package types, and packaging. All combinations use the following naming conventions. When ordering, be sure to give the correct part number using these naming conventions.

MN13801-R (TA)

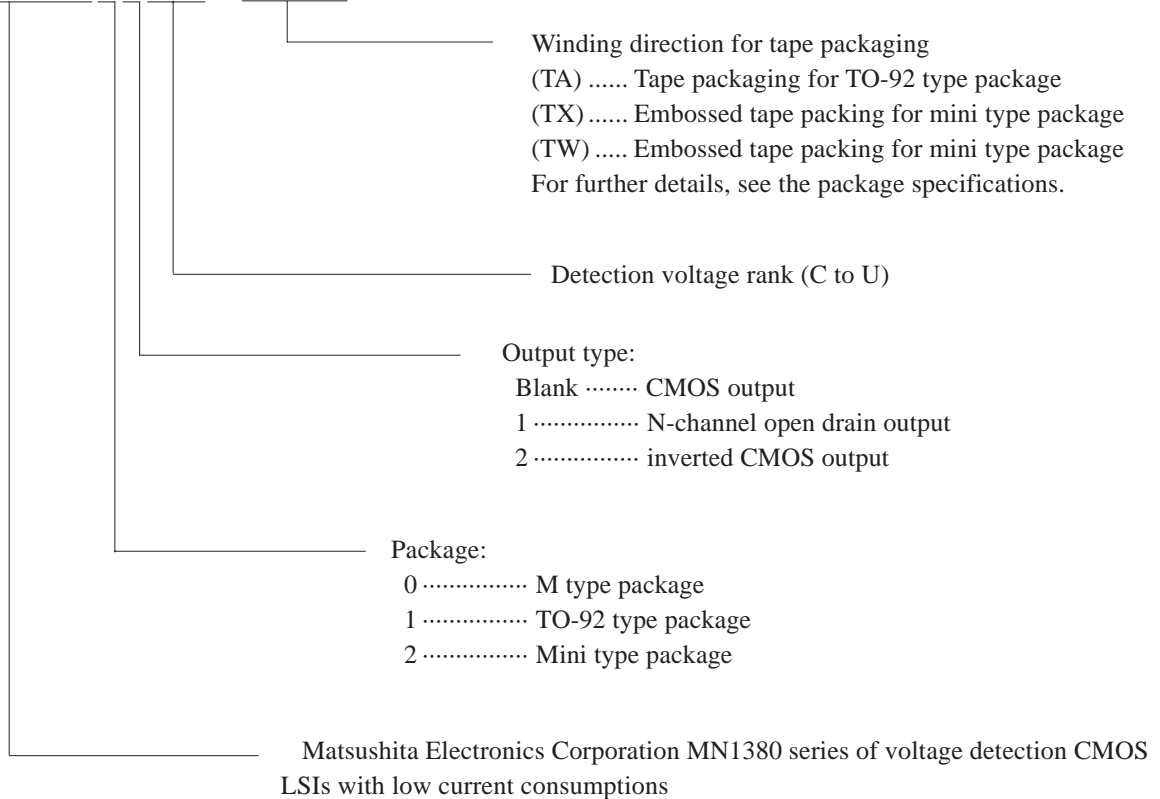

(Example)

MN13821-R (TW)

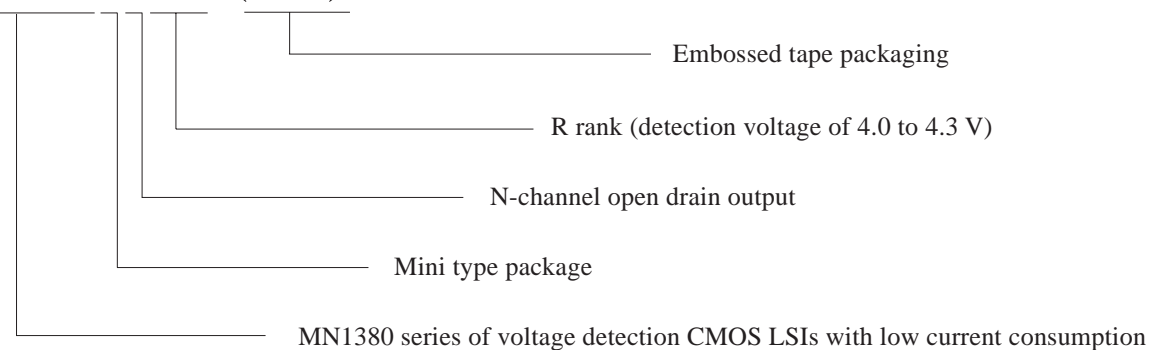

■ Minimum Packaging Unit

- Bulk (M and TO-92 types) 1,000
- Magazine (Mini type) 50
- Taping (Mini and TO-92 types) 3,000

■ Series Lineup

Output	Package	M type Package	TO-92 type Package	Mini type Package
CMOS output		MN1380	MN1381	MN1382
N-channel open drain output		MN13801	MN13811	MN13821
Inverted CMOS output		MN13802	MN13812	MN13822

■ Detection Ranks (on Voltage)

Rank	Detection Voltage for Drop in Power Supply Voltage (V_{DL})		Unit	Detection Voltage Hysteresis Width (ΔV_D)		Unit
	min	max		min	max	
C	2.0	2.2	V	50	300	mV
D	2.1	2.3				
E	2.2	2.4				
F	2.3	2.5				
G	2.4	2.6				
H	2.5	2.7				
J	2.6	2.9	V	50	300	mV
K	2.8	3.1	V	100	300	mV
L	3.0	3.3				
M	3.2	3.5				
N	3.4	3.7				
P	3.6	3.9				
Q	3.8	4.1				
R	4.0	4.3				
S	4.2	4.5				
T	4.4	4.7				
U	4.6	4.9				

■ Block Diagram

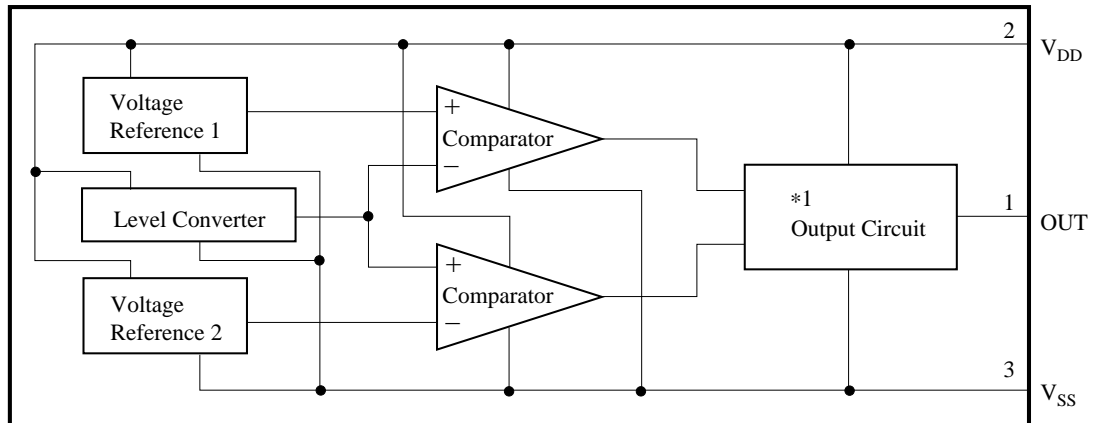

Note *1: Circuits vary slightly depending on the output type (CMOS output, N-channel open drain output, or inverted CMOS output)

■ Pin Descriptions

Pin No.	Symbol	Function Description
1	OUT	Reset signal output pin
2	V _{DD}	Power supply pin
3	V _{SS}	Ground pin

■ Absolute Maximum Ratings $V_{SS}=0V, T_a=25^{\circ}C$

Parameter	Symbol	Rating	Unit
Power supply voltage	V_{DD}	7.0	V
Output voltage	V_O	-0.3 to $V_{DD}+0.3$	V
Operating ambient temperature	T_a	-20 to +70	$^{\circ}C$
Storage temperature	T_{stg}	-55 to +125	$^{\circ}C$

■ Recommended Operating Conditions $V_{SS}=0V, T_a=25^{\circ}C$

Parameter	Symbol	Conditions	min	typ	max	Unit
Power supply voltage	V_{DD}	See Figures 1 and 4.	1.5		6.0	V

■ Electrical Characteristics

 1) DC Characteristics $V_{SS}=0V, T_a=-20^{\circ}C$ to $+70^{\circ}C$

Parameter	Symbol	Conditions	min	typ	max	Unit	
Power supply current	I_{DD}	$V_{DD} = 5V$ *1 Load resistance = 10 k Ω		1	5	μA	
Detection voltage for drop in power supply voltage *2	V_{DL}	$T_a=25^{\circ}C$	*2		*2	V	
Detection voltage hysteresis width *2	ΔV_D	See Figures 1 and 4.	*2		*2	mV	
"H" level output voltage	V_{OH}	CMOS output	$I_{OH}=-40\mu A$	$0.8V_{DD}$		V_{DD}	V
		Inverted CMOS output	$V_{DD}=1.8V$ $I_{OH}=-0.5mA$	0.8		$V_{DD}-1.5$	
"L" level output voltage	V_{OL}	N-channel open drain output	$V_{DD}=1.8V$ $I_{OL}=0.7mA$	V_{SS}		0.4	V
		Inverted CMOS output	$V_{DD}=6.0V$ $I_{OH}=0.3mA$	V_{SS}		0.6	

Notes

*1: This includes the output pin's leakage current.

*2: For particulars, see the detection voltage rank table.

■ Electrical Characteristics (continued)

2) AC Characteristics $V_{SS}=0V$, $T_a=25^\circ C$

Parameter	Symbol	Conditions	Rank	Allowable Value (typ)			Unit
				MN1380 MN1381 MN1382	MN13801 MN13811 MN13821	MN13802 MN13812 MN13822	
Reset release time	t_{OH}	See Figures 2 and 3.	C	3.0	2.5	230.0	μs
			D				
			E				
			F				
			G				
			H				
			J	3.0	3.0	100.0	
			K				
			L				
			M	2.0	4.0	30.0	
			N				
			P				
Q							
R							
S							
T							
Reset time	t_{OL}	See Figures 2 and 3.	C	250.0	160.0	3.0	μs
			D				
			E				
			F				
			G				
			H				
			J	115.0	100.0	3.0	
			K				
			L				
			M	15.0	35.0	3.0	
			N				
			P				
Q							
R							
S							
T							

■ Description of Operation

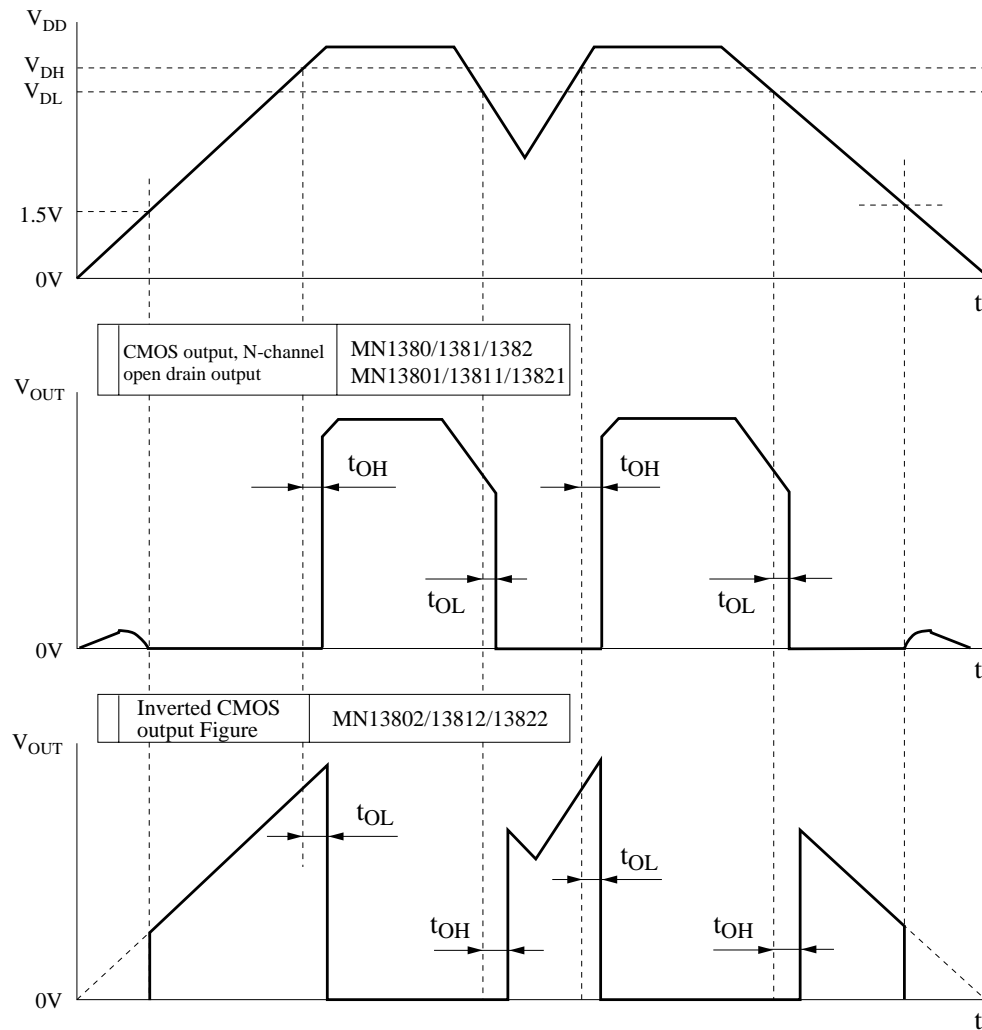

Figure 1. Description of Operation

Notes

- 1: Output cannot be specified for power supply voltages under 1.5 V because operation is not guaranteed for that range.
- 2: V_{DL} : Detection voltage for drop in power supply voltage
 V_{DH} : Detection voltage for rise in power supply voltage
 t_{OL} : Time lag between the time that the power supply voltage reaches the detection voltage (V_{DL} or V_{DH}) and the time that the output pin (OUT) goes to "L" level.
 t_{OH} : Time lag between the time that the power supply voltage reaches the detection voltage (V_{DL} or V_{DH}) and the time that the output pin (OUT) goes to "H" level.
- 3: These characteristics for the N-channel open drain output are when a load resistor is connected between the OUT and V_{DD} pins.

■ Description for Measuring the Output Characteristics

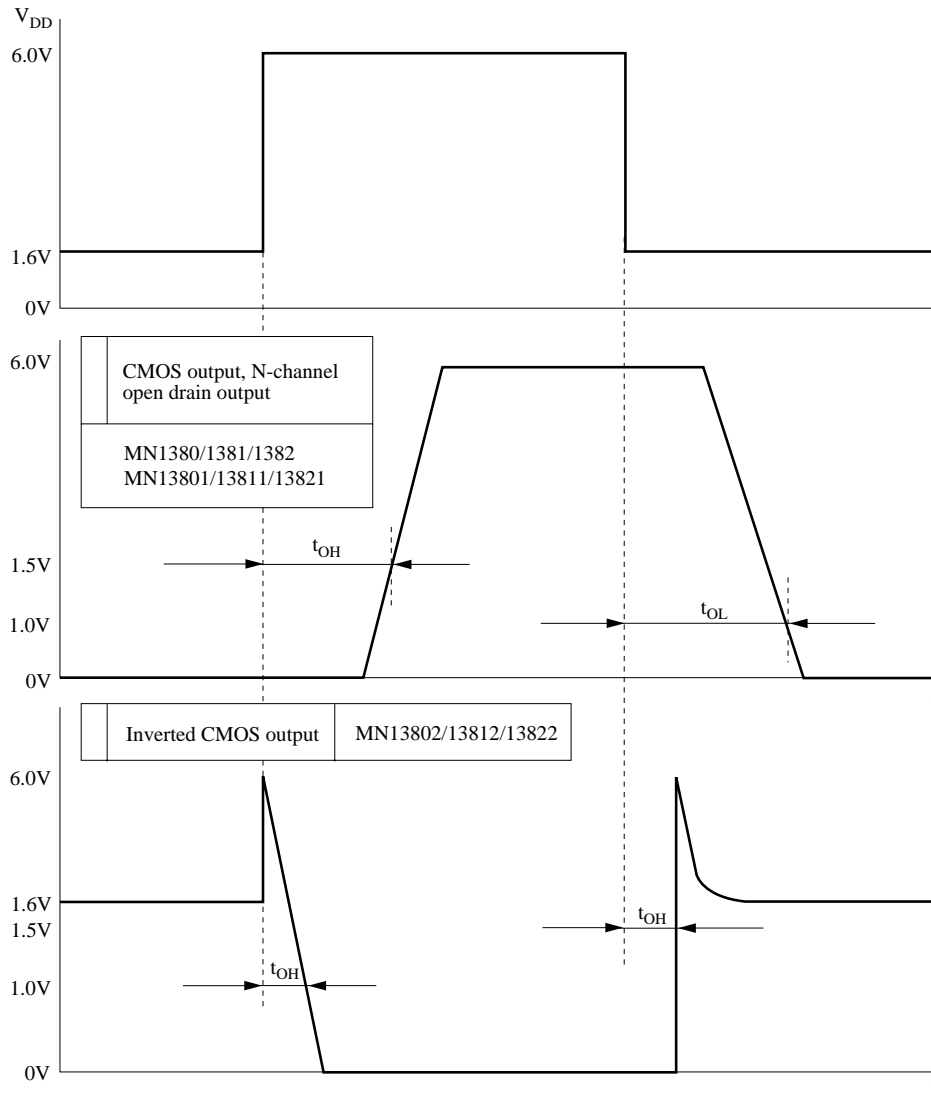

Figure 2. Description chart of Measuring the Output Characteristics

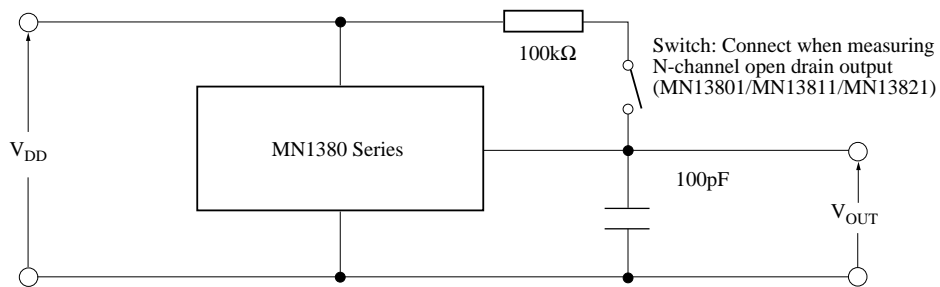

Figure 3. Circuit for Measuring the Output Characteristics

■ Description for Measuring the I/O Characteristics

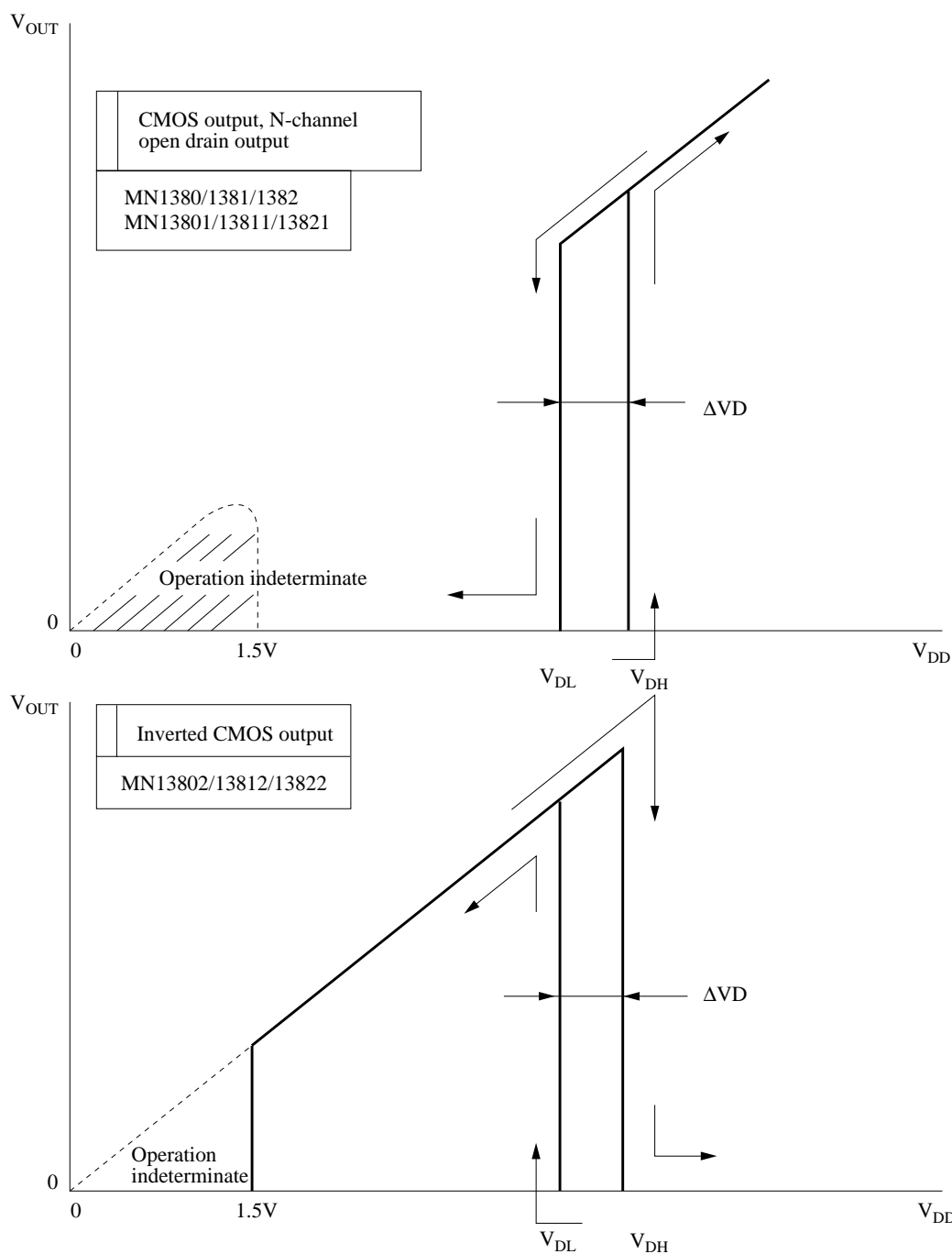

Figure 4. Description chart for Measuring the I/O Characteristics

Notes

- 1: Output cannot be specified for power supply voltages under 1.5 V because operation is not guaranteed for that range.
- 2: V_{DL} : Detection voltage for drop in power supply voltage
 V_{DH} : Detection voltage for rise in power supply voltage
- 3: These characteristics for the N-channel open drain output are when a load resistor is connected between the OUT and V_{DD} pins.

■ Application Circuit Example

Connect resistors, capacitors, and the like only to the output pin on the MN1380 series element. Note that connecting them to the Power source pins changes V_{DH} , V_{DL} , and ΔV_D .

Sample Circuit 1

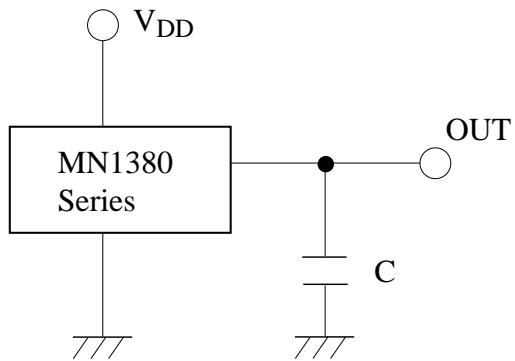

Sample Circuit 2

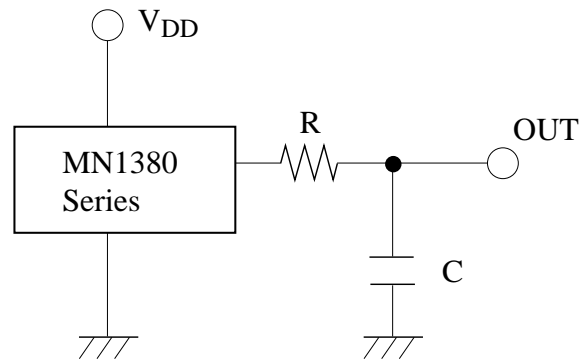

Select the values of R and C to match the application.

■ Package Dimensions (Unit:mm)

M type package

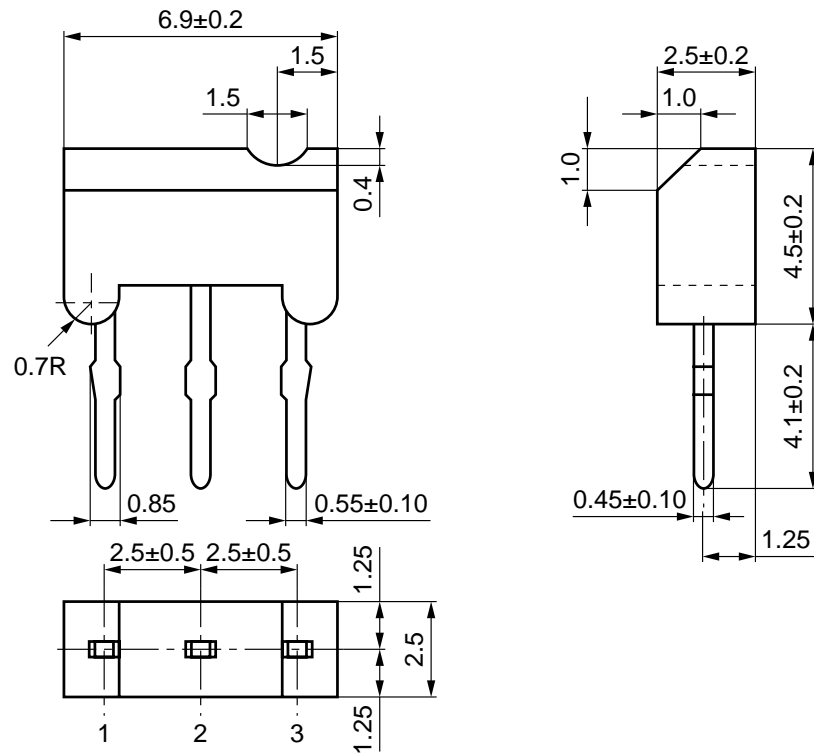

■ Package Dimensions (continued)(Unit:mm)

TO-92 type package

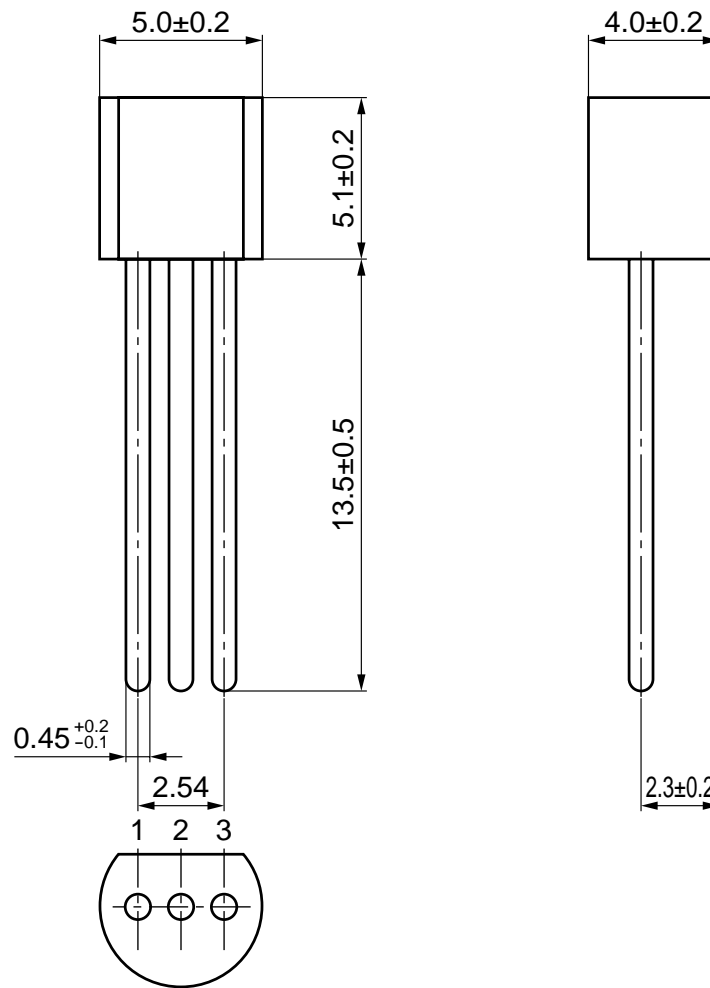

■ Package Dimensions (continued)(Unit:mm)

Mini type package

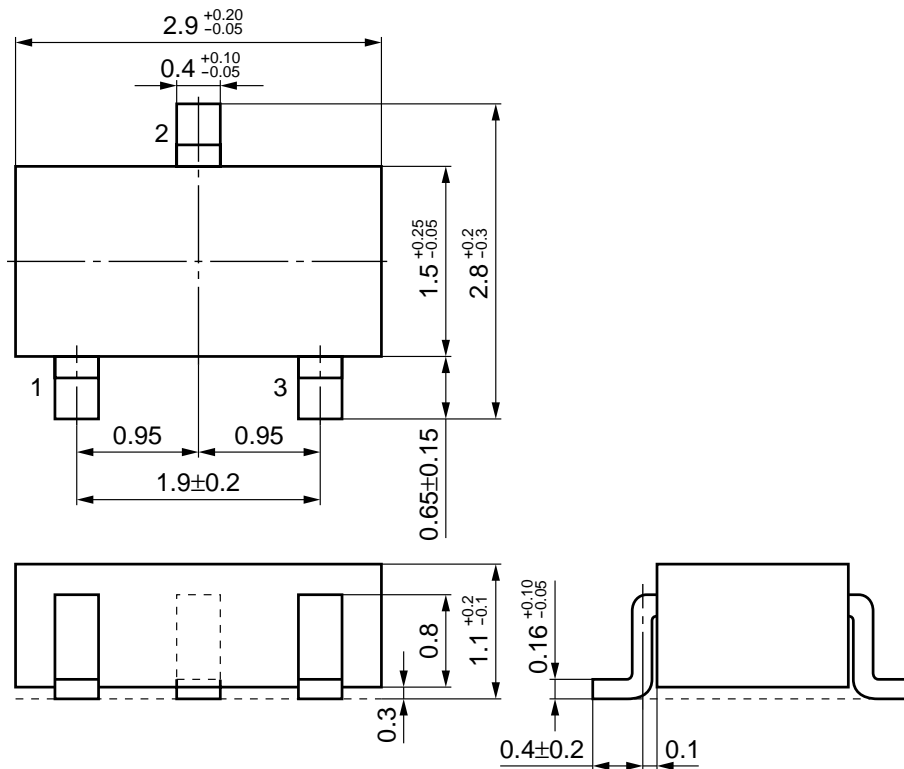

■ Reference Characteristics

The following characteristics curves represent results from a specific sample therefore they do not guarantee the characteristics for the final product.

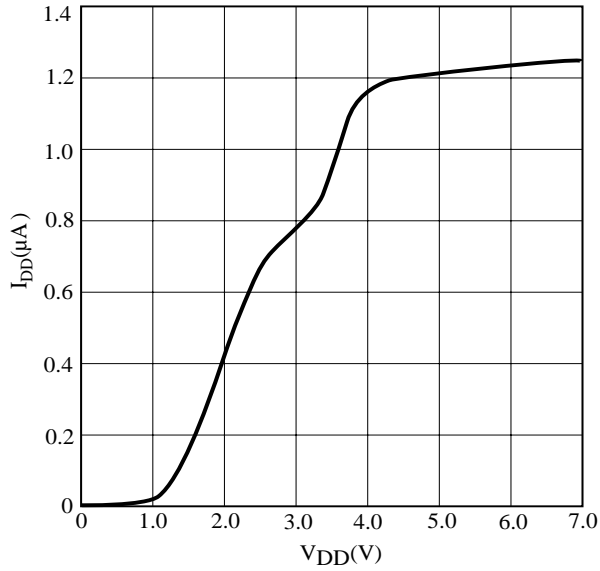

Figure 5.a. I_{DD} vs. V_{DD} Characteristic (Rank Q)

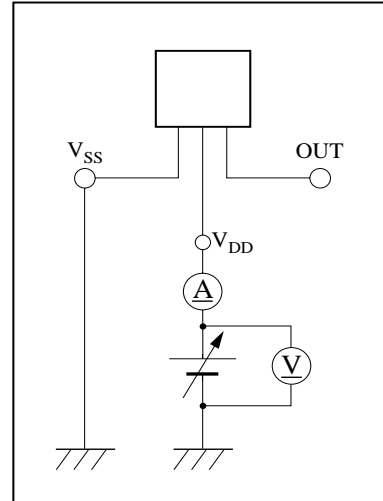

Figure 5.b. Measurement Circuit

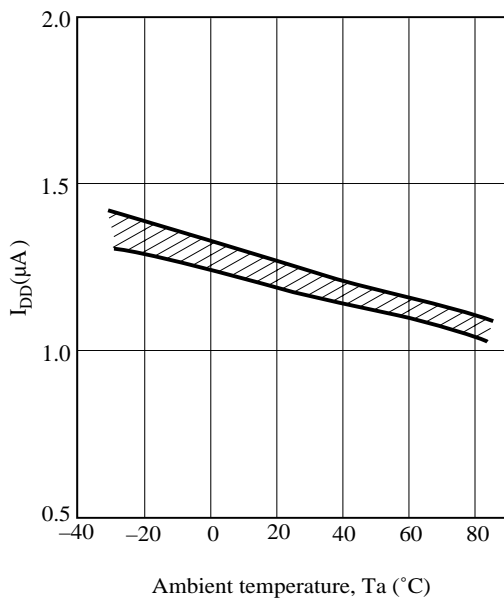

Figure 6.a. I_{DD} Temperature Characteristic (Rank Q)

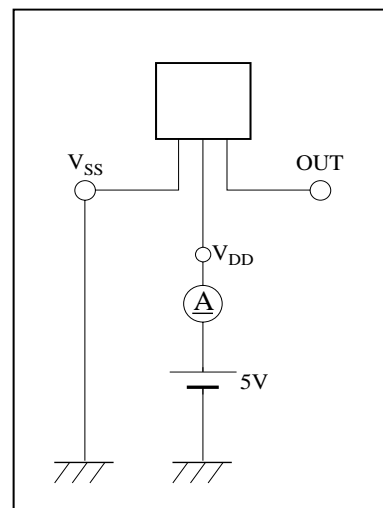

Figure 6.b. Measurement Circuit

■ Reference Characteristics (continued)

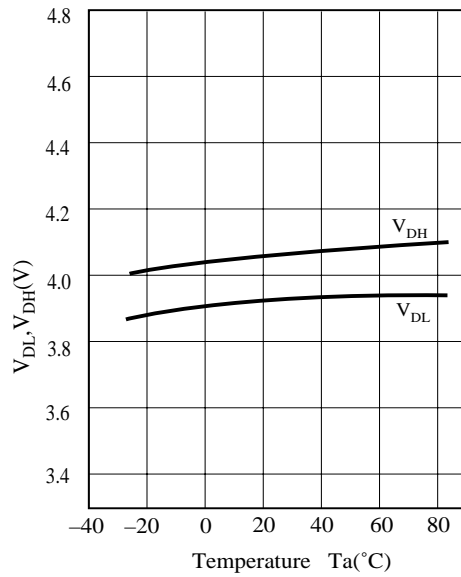

Figure 7.a. V_{DL}/V_{DH} Temperature Characteristic (Rank Q)

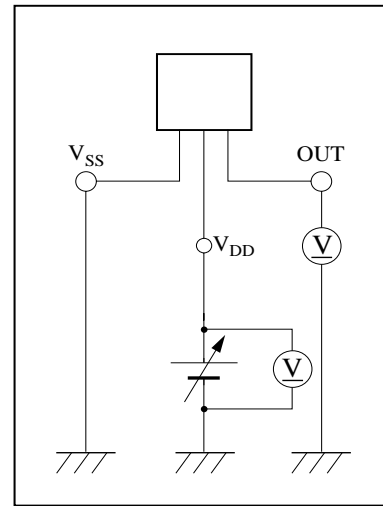

Figure 7.b. Measurement Circuit

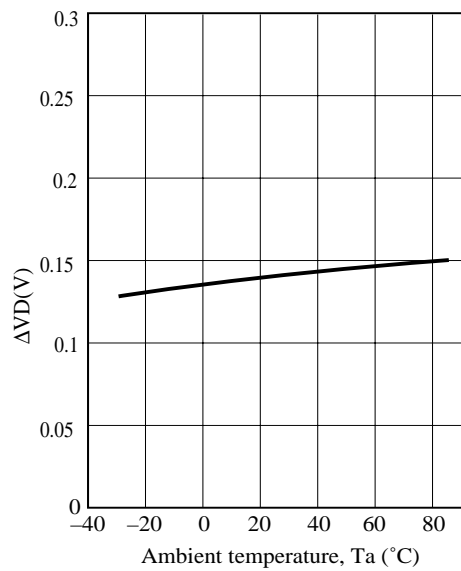

Figure 8.a. ΔVD Temperature Characteristic (Rank Q)

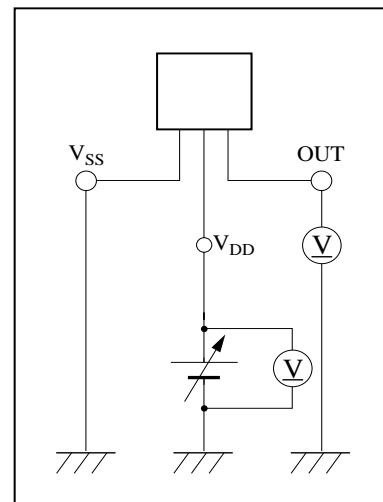

Figure 8.b. Measurement Circuit

■ Reference Characteristics (continued)

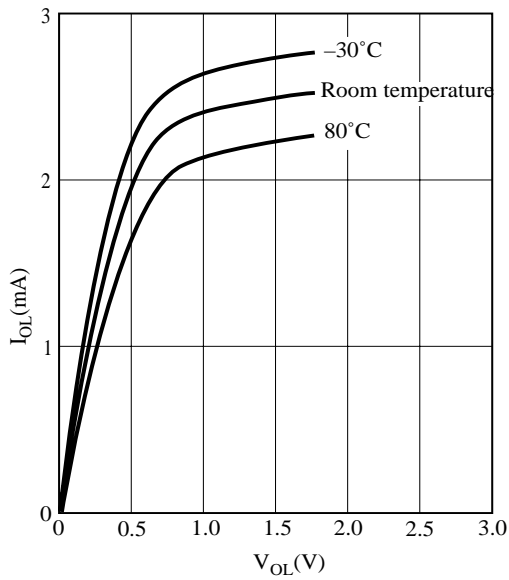

Figure 9.a. I_{OL} vs. V_{OL} Characteristic

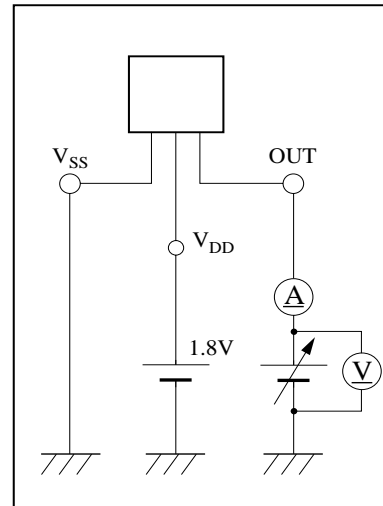

Figure 9.b. Measurement Circuit

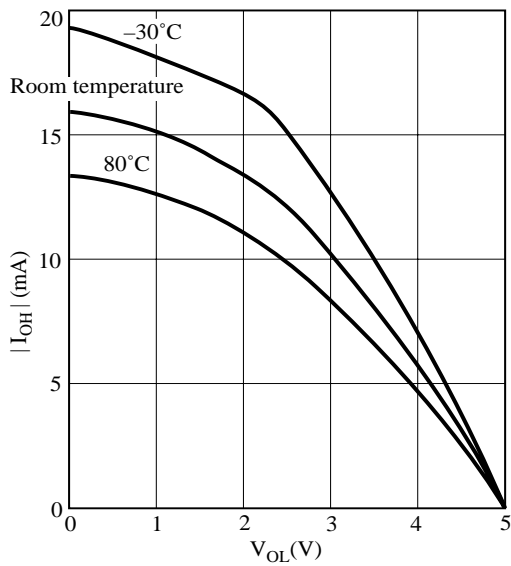

Figure 10.a. I_{OH} vs. V_{OH} Characteristic

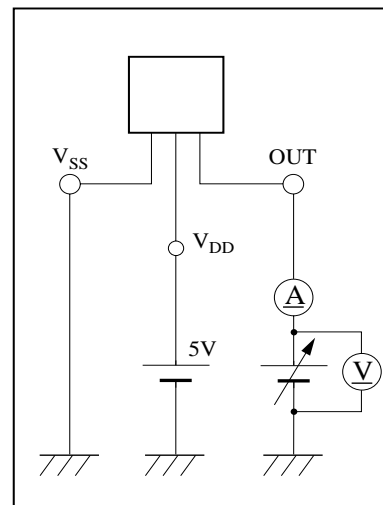

Figure 10.b. Measurement Circuit

■ Reference Characteristics (continued)

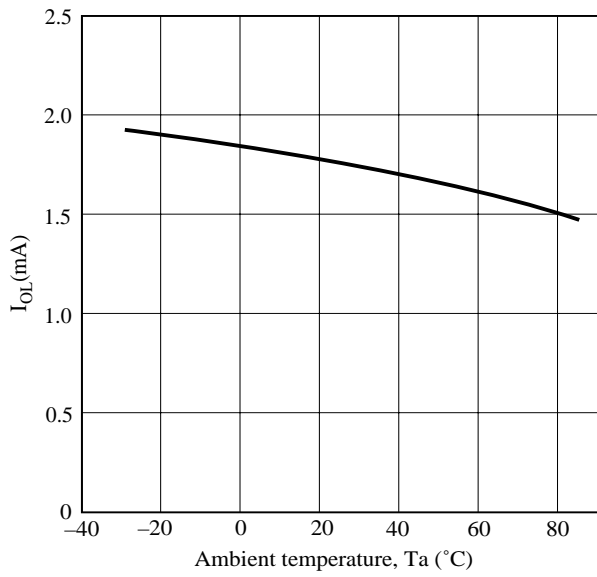

Figure 11.a. I_{OL} vs. Temperature Characteristic

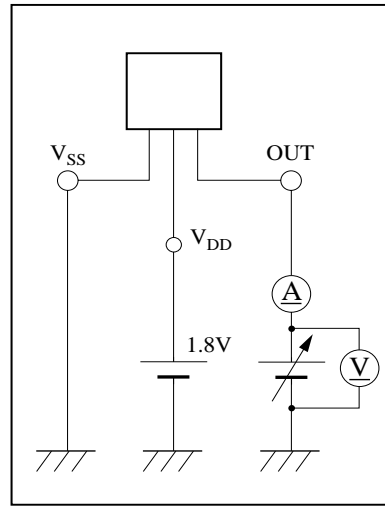

Figure 11.b. Measurement Circuit

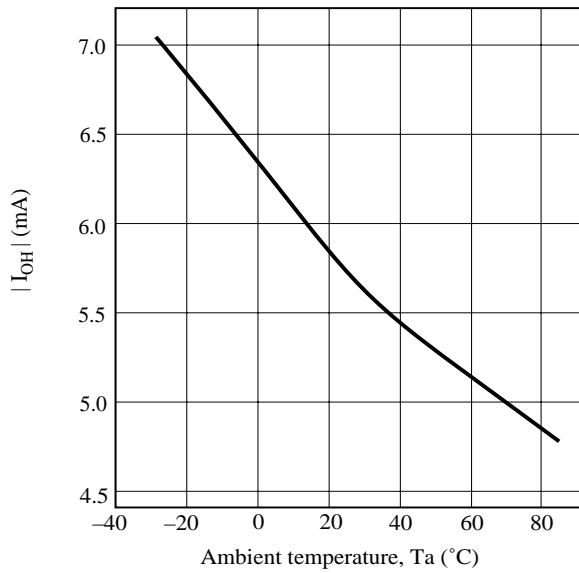

Figure 12.a. I_{OH} vs. Temperature Characteristic

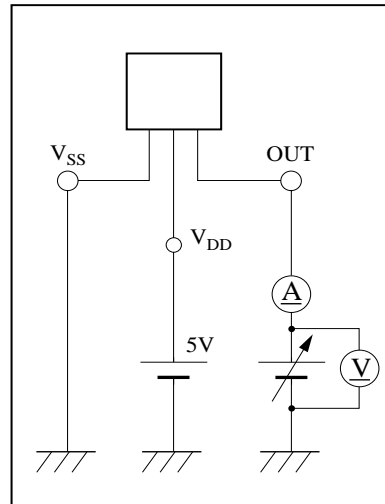

Figure 12.b. Measurement Circuit

■ TO-92 Type Package Taping-Specifications (MN1381/MN13811/MN13812)

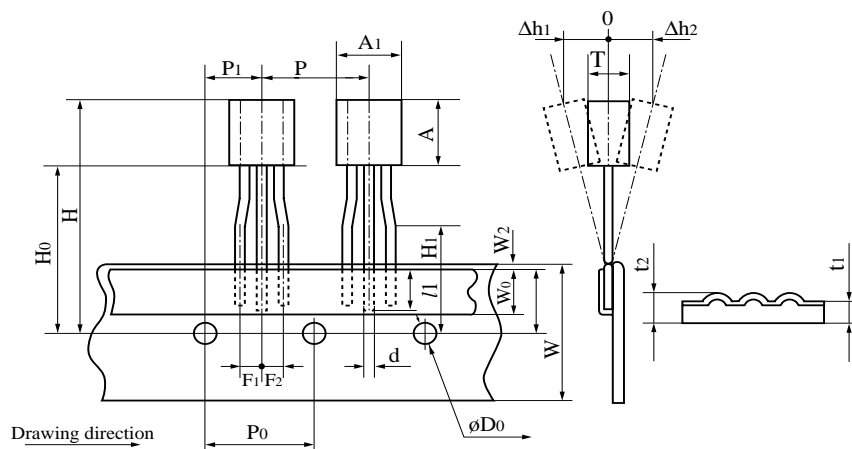

Figure 13. TO-92 Type Package Taping-Dimensions (Ammunition pack)

TO-92 Type Package Taping Dimensions (Ammunition pack)

Name	Symbol	Length (mm)
Product height*	A	5.3 max
Product width*	A1	5.2 max
Product thickness*	T	4.2 max
Lead width*	d	0.45 ^{+0.15} _{-0.1}
Taped lead length	l1	2.0 max
Product pitch	P	12.7±1.0
Feed hole pitch	P0	12.7±0.3
Feed hole position	P1	6.35±0.5
Lead spacing	F1, F2	2.5 ^{+0.5} _{-0.2}
Product deflection angle	Δh1, Δh2	2.0 max
Tape width	W	18.0 ^{+1.0} _{-0.5}

Name	Symbol	Length (mm)
Adhesive tape width	W0	6.0±0.5
Feed hole position	W1	9.0±0.5
Adhesive tape position	W2	0.5 max
Distance to top of product	H	25.0 max
Distance to bottom of product	H0	19.0±0.5
Lead clinch height	H1	16.0±0.5
Feed hole diameter	D0	4.0±0.2
Tape thickness	t1	0.7±0.2
Total tape thickness	t2	1.5 max

Note*1: For further details, see the specifications issued separately.

W	H	D
330	250	41

Unit: mm

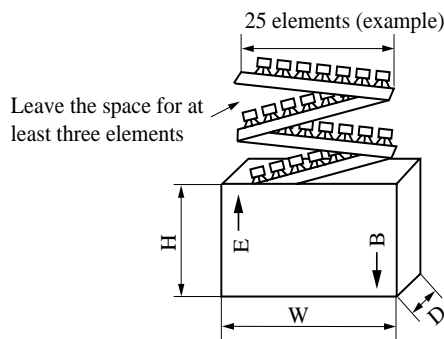
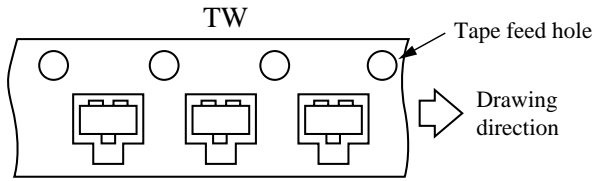

Figure 14. Box Dimensions for TO-92 Type Packages with Ammunition pack

■ Embossed Taping Specifications for Mini Type Package (MN1382/MN13821/MN13822)

There is a choice of two orientations, TW and TX, for the product relative to the tape.



(Marking surface on top)

Figure 15. TW Orientation

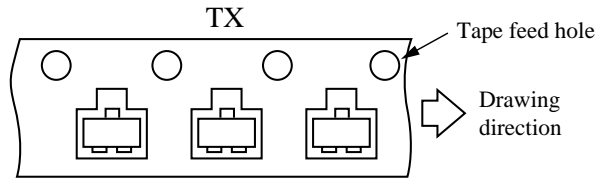

(Marking surface on top)

Figure 16. TX Orientation

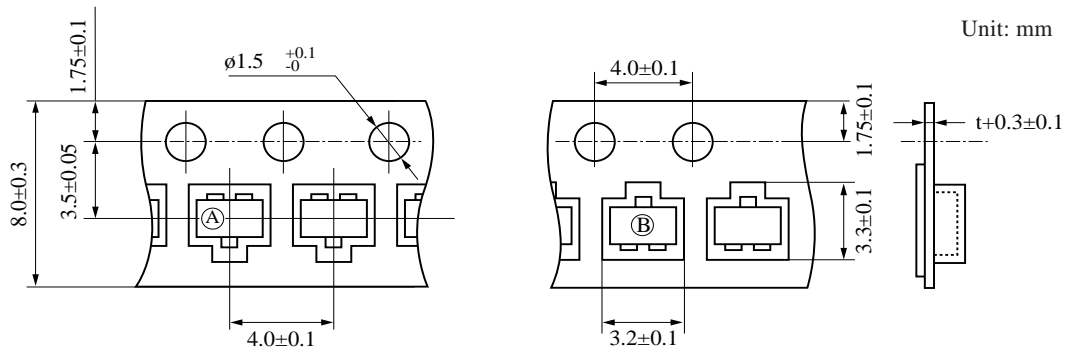

Product orientation A is labeled TW; orientation B, TX.

Figure 17. Embossed Taping Dimensions for Mini Type Package

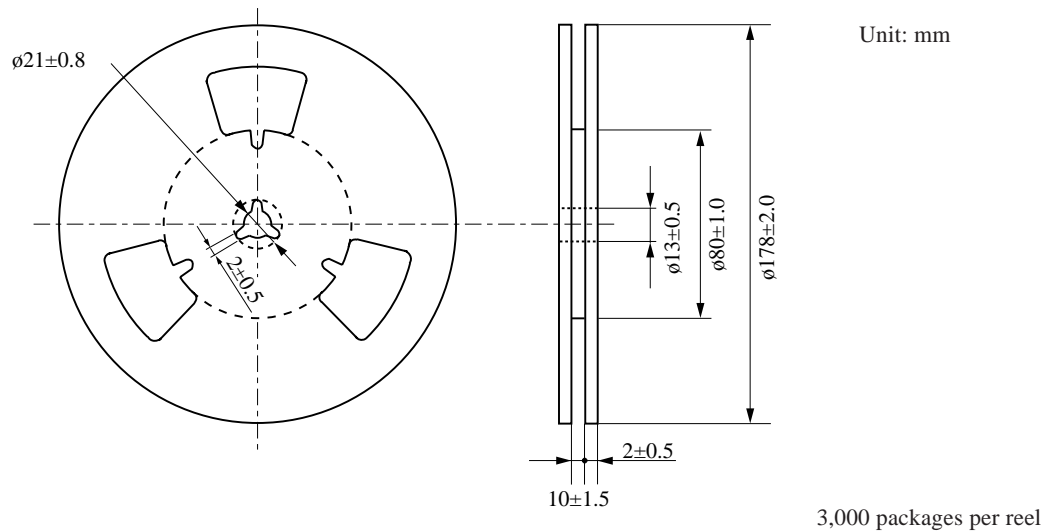

Figure 18. Embossed Taping Reel Dimensions for Mini Type Package

■ Reliability Testing Results for MN1380 Series

(1) M type package (MN1380/MN13801/MN13802) and TO-92 type package (MN1381/MN13811/MN13812)

Test Subjects	Test Conditions	Results
Operating lifetime test	$V_{DD}=5.5V$, $T_a=125^{\circ}C$, $t=1000hrs$	0/15
High-temperature storage test	$T_a=150^{\circ}C$, $t=1000hrs$	0/15
Low-temperature storage test	$T_a=-65^{\circ}C$, $t=1000hrs$	0/15
High-temperature, high-humidity storage test	$T_a=85^{\circ}C$, $RH=85\%$, $t=1000hrs$	0/15
High-temperature, high-humidity bias test	$V_{DD}=5.5V$, $T_a=85^{\circ}C$, $RH=85\%$, $t=1000hrs$	0/15
Thermal shock test	$T_a=150^{\circ}C$ and $-65^{\circ}C$. Five minutes at each temperature for ten cycles	0/15
Temperature cycle test	$T_a=150^{\circ}C$ and $-65^{\circ}C$. Thirty minutes at each temperature for ten cycles	0/15
Pressure cooker test	Two atmospheres for 50 hours at ambient temperature (T_a) of $121^{\circ}C$	0/15
Soldering test	Ambient temperature (T_a) of $230^{\circ}C$ for five seconds	0/15
Solder heat resistance test	Ambient temperature (T_a) of $270^{\circ}C$ for ten seconds	0/15

(2) Mini type package (MN1382/MN13821/MN13822)

Test Subjects	Test Conditions	Results
Operating lifetime test	$V_{DD}=5.5V$, $T_a=125^{\circ}C$, $t=1000hrs$	0/15
High-temperature storage test	$T_a=150^{\circ}C$, $t=1000hrs$	0/15
Low-temperature storage test	$T_a=-65^{\circ}C$, $t=1000hrs$	0/15
High-temperature, high-humidity storage test	$T_a=85^{\circ}C$, $RH=85\%$, $t=1000hrs$	0/15
High-temperature, high-humidity bias test	$V_{DD}=5.5V$, $T_a=85^{\circ}C$, $RH=85\%$, $t=1000hrs$	0/15
Thermal shock test	$T_a=150^{\circ}C$ and $-65^{\circ}C$. Five minutes at each temperature for ten cycles	0/15
Temperature cycle test	$T_a=150^{\circ}C$ and $-65^{\circ}C$. Thirty minutes at each temperature for ten cycles	0/15
Pressure cooker test *1	Two atmospheres for 24 hours at ambient temperature (T_a) of $121^{\circ}C$	0/15
Soldering test	Ambient temperature (T_a) of $230^{\circ}C$ for five seconds	0/15
Solder heat resistance test *1	Ambient temperature (T_a) of $260^{\circ}C$ for five seconds	0/15

Note*1: Note that the testing conditions for the mini package differ from those for the other two packages.