

Features

- Operating voltage: 2.4V~5.0V
- Up to 1μs (0.5μs) instruction cycle with 4MHz (8MHz) system clock
- System clock: 4MHz~8MHz (2.4V)
- RC oscillator for system clock
- Eight I/O pins
- 2K×14-bit program ROM
- 80×8-bit RAM
- Two 8-bit programmable timer counter with 8-stage prescaler and one time base counter
- Watchdog Timer
- 4-level subroutine nesting
- HALT function and wake-up feature reduce power consumption
- PWM circuit direct drive speaker or output by transistor
- 32-pin DIP package

Applications

- Intelligent educational leisure products
- Alert and warning systems
- Sound effect generators

General Description

The HT83XXX series are 8-bit high performance microcontroller with voice synthesizer and tone generator. The HT83XXX is designed for applications on multiple I/Os with sound effects, such as voice and melody. It can provide various sampling rates and beats, tone levels, tempos for speech synthesizer and melody generator.

The HT83XXX is excellent for versatile voice and sound effect product applications. The efficient MCU instructions allow users to program the powerful custom applications. The system frequency of HT83XXX can be up to 8MHz under 2.4V and include a HALT function to reduce power consumption.

Selection Table

Body	HT83003	HT83006	HT83009	HT83018	HT83036	HT83048	HT83072
Voice ROM Size	64K-bit	128K-bit	192K-bit	384K-bit	768K-bit	1024K-bit	1536K-bit
Voice Length	3 sec	6 sec	9 sec	18 sec	36 sec	48 sec	72 sec

Block Diagram

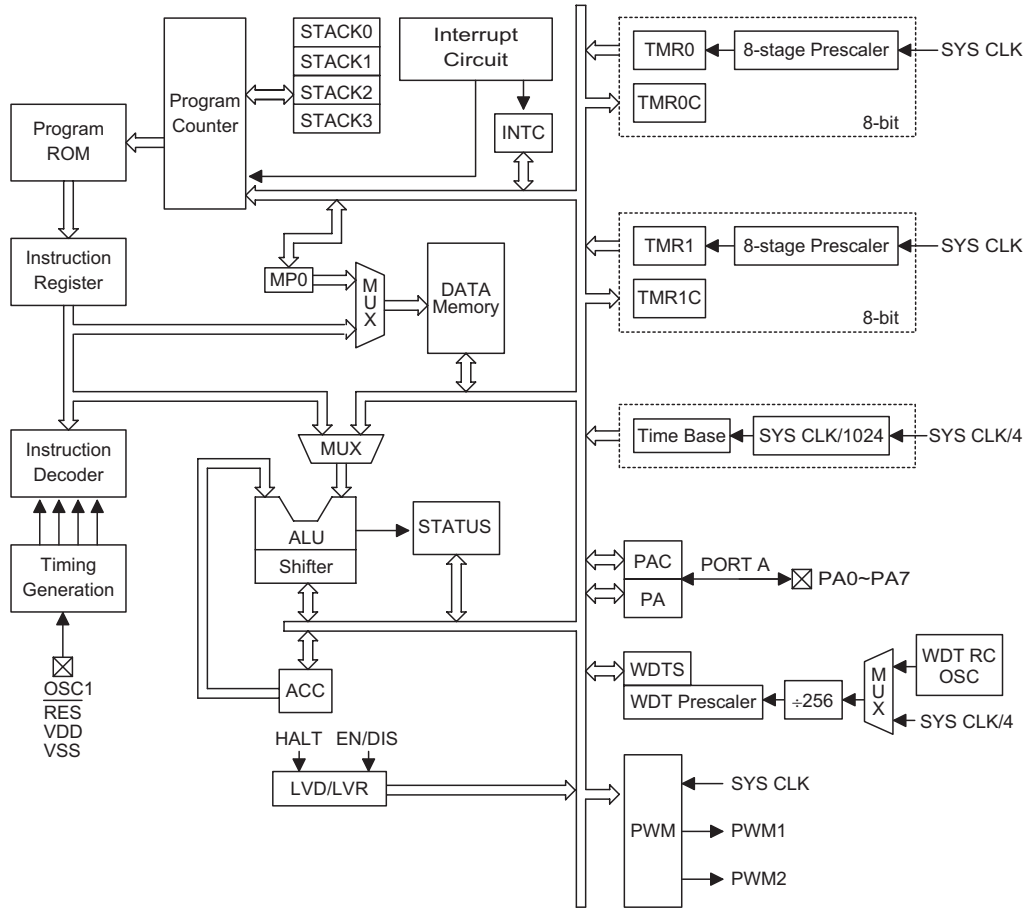

Pin Assignment

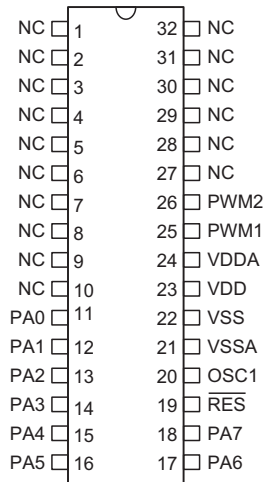

HT83003/HT83006/HT83009/HT83018
 HT83036/HT83048/HT83072
 - 32 DIP-A

Pad Assignment

HT83003/HT83006/HT83009

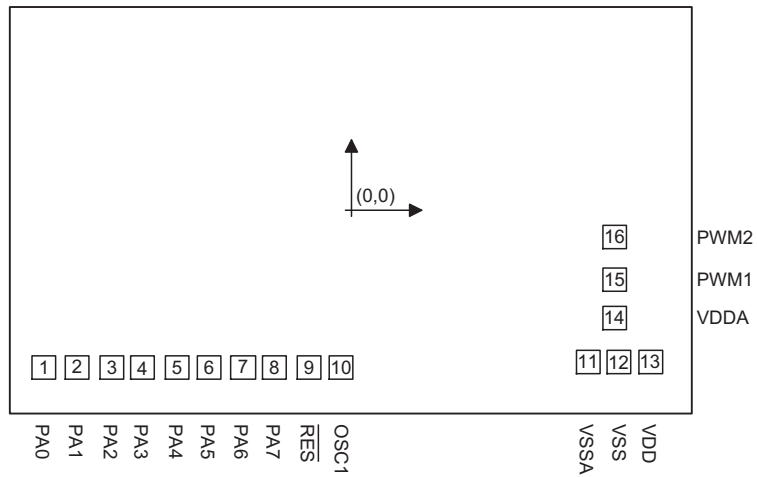

Chip size: $2220 \times 1355 (\mu\text{m})^2$

* The IC substrate should be connected to VSS in the PCB layout artwork.

HT83018/HT83036

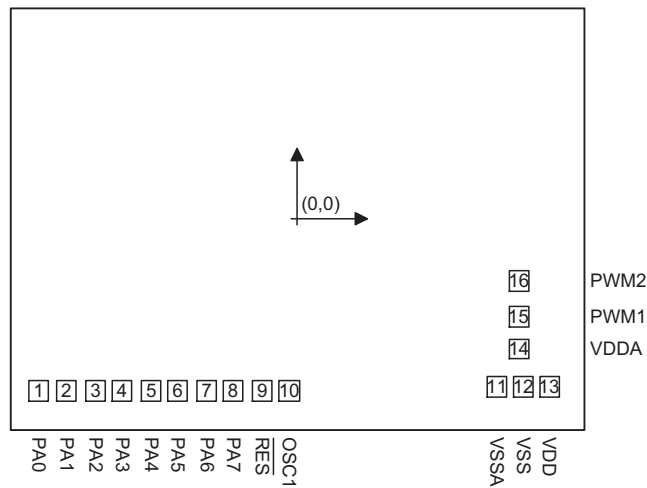

Chip size: $2220 \times 1660 (\mu\text{m})^2$

* The IC substrate should be connected to VSS in the PCB layout artwork.

HT83048/HT83072

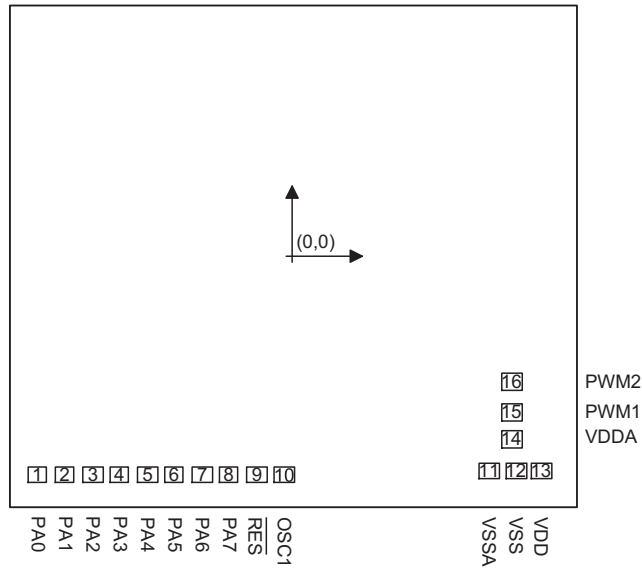

Chip size: 2220 × 2335 (μm)²

* The IC substrate should be connected to VSS in the PCB layout artwork.

Pad Coordinates

HT83003/HT83006/HT83009

Pad No.	X	Y	Pad No.	X	Y
1	-982.145	-508.050	9	-135.205	-508.050
2	-876.845	-508.050	10	-31.229	-508.050
3	-766.245	-508.050	11	758.645	-490.400
4	-666.245	-508.050	12	858.645	-490.400
5	-555.645	-508.050	13	958.645	-490.400
6	-455.645	-508.050	14	841.895	-345.550
7	-345.045	-508.050	15	841.895	-224.050
8	-245.045	-508.050	16	841.895	-85.450

HT83018/HT83036

Pad No.	X	Y	Pad No.	X	Y
1	-982.145	-660.550	9	-135.205	-660.550
2	-876.845	-660.550	10	-31.229	-660.550
3	-766.245	-660.550	11	758.645	-642.900
4	-666.245	-660.550	12	858.645	-642.900
5	-555.645	-660.550	13	958.645	-642.900
6	-455.645	-660.550	14	841.895	-498.050
7	-345.045	-660.550	15	841.895	-376.550
8	-245.045	-660.550	16	841.895	-237.950

HT83048/HT83072

Pad No.	X	Y	Pad No.	X	Y
1	-982.145	-998.050	9	-135.205	-998.050
2	-876.845	-998.050	10	-31.229	-998.050
3	-766.245	-998.050	11	758.645	-980.400
4	-666.245	-998.050	12	858.645	-980.400
5	-555.645	-998.050	13	958.645	-980.400
6	-455.645	-998.050	14	841.895	-835.550
7	-345.045	-998.050	15	841.895	-714.050
8	-245.045	-998.050	16	841.895	-575.450

Pad Description

Pad Name	I/O	Mask Option	Description
PA0~PA7	I/O	Wake-up, Pull-high or None	Bidirectional 8-bit I/O port. Each bit can be configured as a wake-up input by mask option. Software instructions determine the CMOS output or Schmitt trigger input with or without pull-high resistor (mask option).
VSS	—	—	Negative power supply, ground
VDD	—	—	Positive power supply
VSSA	—	—	PWM negative power supply, ground
VDDA	—	—	PWM positive power supply, ground
$\overline{\text{RES}}$	I	—	Schmitt trigger reset input, active low
OSC1	—	RC	OSC1 is connected to an RC network for the internal system clock.
PWM1, PWM2	O	—	PWM output for driving a external transistor or speaker

Absolute Maximum Ratings

Supply Voltage	$V_{SS}+2.4V$ to $V_{SS}+5.2V$	Storage Temperature	$-50^{\circ}C$ to $125^{\circ}C$
Input Voltage	$V_{SS}-0.3V$ to $V_{DD}+0.3V$	Operating Temperature	$-20^{\circ}C$ to $70^{\circ}C$

Note: These are stress ratings only. Stresses exceeding the range specified under "Absolute Maximum Ratings" may cause substantial damage to the device. Functional operation of this device at other conditions beyond those listed in the specification is not implied and prolonged exposure to extreme conditions may affect device reliability.

D.C. Characteristics

Symbol	Parameter	Test Conditions		Min.	Typ.	Max.	Unit
		V_{DD}	Conditions				
V_{DD}	Operating Voltage	—	—	2.4	—	5.2	V
I_{STB}	Standby Current	3V	No load, system HALT	—	1	—	μA
I_{DD}	Operating Current	3V	No load, $f_{SYS}=4MHz$	—	1.2	1.5	mA
I_{OL}	I/O Port Sink Current	3V	$V_{OL}=0.3V$	17	—	—	mA
I_{OH}	I/O Port Source Current	3V	$V_{OH}=2.7V$	-12	—	—	mA
I_O	PWM Source Current	3V	$V_{OL}=0.3V$	121	—	—	mA
I_O	PWM Source Current	3V	$V_{OH}=2.7V$	-81	—	—	mA
V_{IL1}	Input Low Voltage ($\overline{\text{RES}}$)	3V	—	—	1.5	—	V
V_{IH1}	Input High Voltage ($\overline{\text{RES}}$)	3V	—	—	2.2	—	V
f_{SYS}	System Frequency	3V	$R_{OSC}=100k\Omega$	3.7	4.0	4.5	MHz
			$R_{OSC}=62k\Omega$	7.4	8.0	8.6	

A.C. Characteristics

Symbol	Parameter	Test Conditions		Min.	Typ.	Max.	Unit
		V _{DD}	Conditions				
f _{SYS}	System Clock (RC OSC)	3V	—	4	—	8	MHz
f _{TIMER}	Timer Input Frequency	3V	—	0	—	8	MHz
t _{WDTOSC}	Watchdog Oscillator	3V	—	45	90	180	μs
t _{WDT}	Watchdog Time-out Period (RC)	3V	Without WDT prescaler	12	23	45	ms
t _{RES}	External Reset Low Pulse Width	—	—	1	—	—	μs
t _{SST}	System Start-up Timer Period	—	Power-up or wake-up from HALT	—	1024	—	t _{SYS}

Characteristics Curves

R vs. F Characteristics Curve

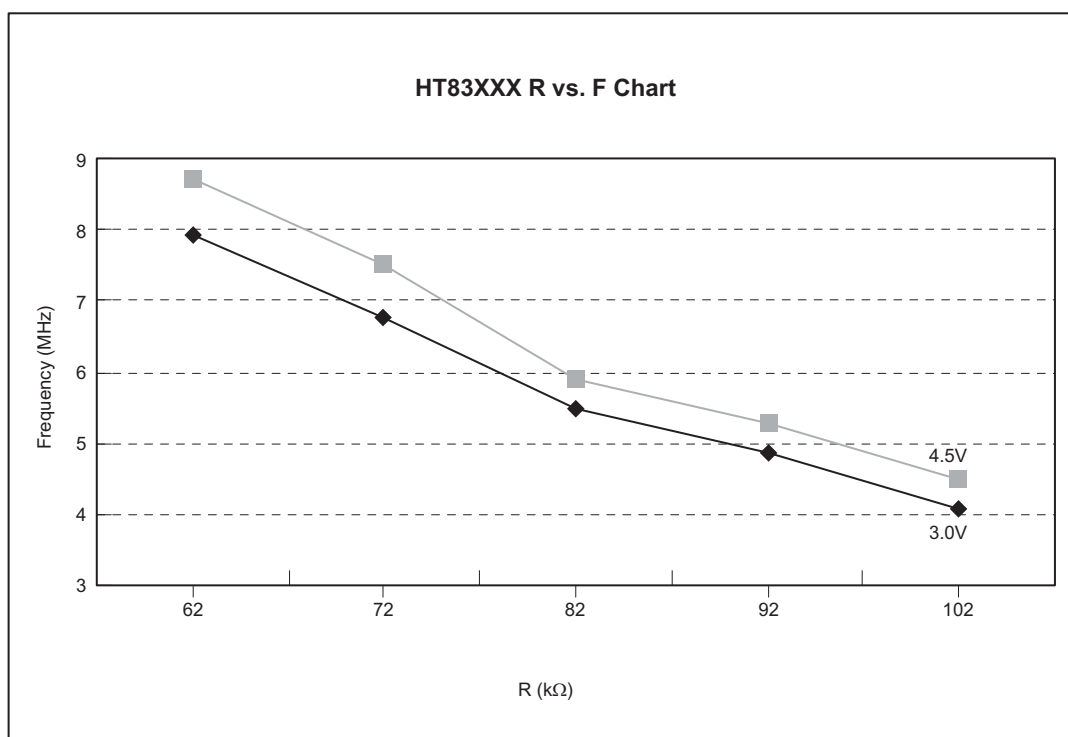

V vs. F Characteristics Curve

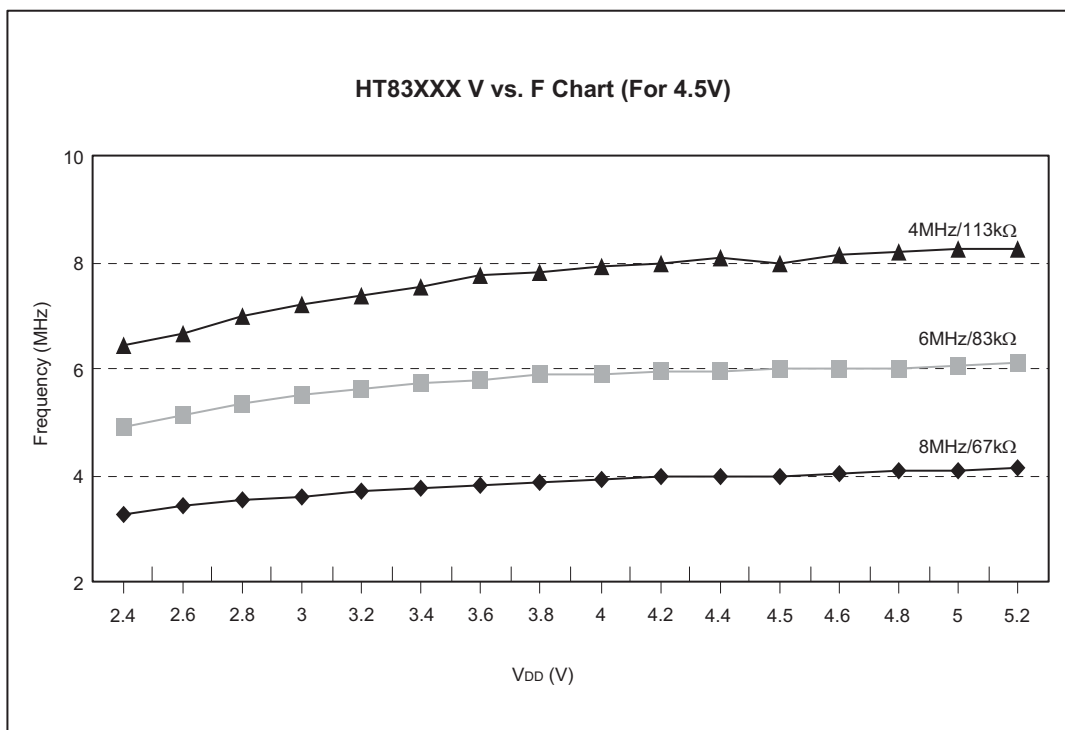
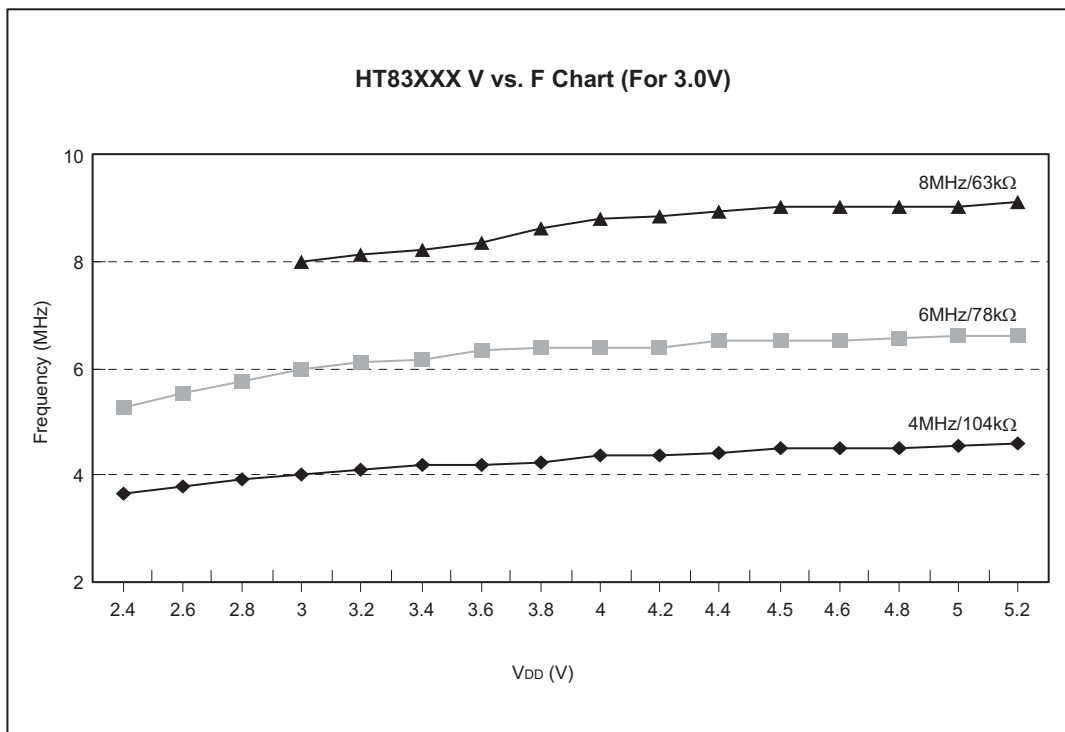

Functional Description

Execution Flow

The system clock for the HT83XXX series is derived from RC oscillator. It is internally divided into four non-overlapping clocks. One instruction cycle consists of four system clock cycles.

Instruction fetching and execution are pipelined in such a way that a fetch takes one instruction cycle while decoding and execution takes the next instruction cycle. However, the pipelining scheme causes each instruction to effectively execute within one cycle. If an instruction changes the program counter, two cycles are required to complete the instruction.

Program Counter – PC

The 11-bit program counter (PC) controls the sequence in which the instructions stored in program ROM are executed.

After accessing a program memory word to fetch an instruction code, the contents of the program counter are

incremented by one. The program counter then points to the memory word containing the next instruction code.

When executing a jump instruction, conditional skip execution, loading PCL register, subroutine call, initial reset, internal interrupt or return from subroutine, the PC manipulates the program transfer by loading the address corresponding to each instruction.

The conditional skip is activated by instruction. Once the condition is met, the next instruction, fetched during the current instruction execution, is discarded and a dummy cycle takes its place while the correct instruction is obtained.

The lower byte of the program counter (PCL) is a read/write register (06H). Moving data into the PCL performs a short jump. The destination must be within 256 locations.

When a control transfer takes place, an additional dummy cycle is required.

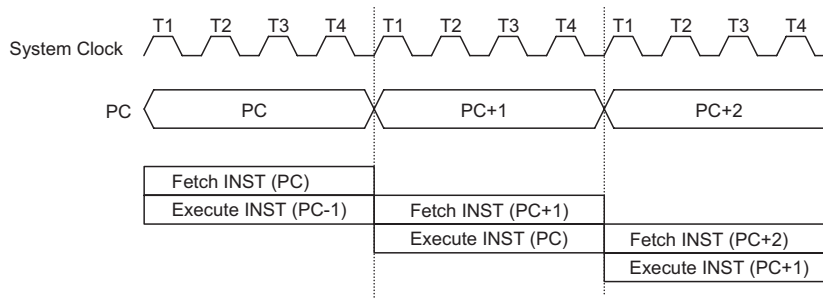

Execution Flow

Mode	Program Counter										
	*10	*9	*8	*7	*6	*5	*4	*3	*2	*1	*0
Initial Reset	0	0	0	0	0	0	0	0	0	0	0
Time Base Overflow	0	0	0	0	0	0	0	0	1	0	0
Timer Counter 0 Overflow	0	0	0	0	0	0	0	1	0	0	0
Timer Counter 1 Overflow	0	0	0	0	0	0	0	1	1	0	0
Skip	PC+2										
Loading PCL	*10	*9	*8	@7	@6	@5	@4	@3	@2	@1	@0
Jump, Call Branch	#10	#9	#8	#7	#6	#5	#4	#3	#2	#1	#0
Return from Subroutine	S10	S9	S8	S7	S6	S5	S4	S3	S2	S1	S0

Program Counter

Note: *10~*0: Program counter bits
#10~#0: Instruction code bits

S10~S0: Stack register bits
@7~@0: PCL bits

Program Memory – ROM

The program memory stores the program instructions that are to be executed. It also includes data, table and interrupt entries, addressed by the program counter along with the table pointer. The program memory size for HT83XXX is 2048×14 bits. Certain locations in the program memory are reserved for special usage:

- Location 000H
This area is reserved for program initialization. The program always begins execution at location 000H each time the system is reset.
- Location 004H
This area is reserved for the time base interrupt service program. If the ETBI (intc.1) is activated, and the interrupt is enabled and the stack is not full, the program will jump to location 004H and begins execution.
- Location 008H
This area is reserved for the 8-bit timer counter 0 interrupt service program. If a timer interrupt results from a timer counter 0 overflow, and if the interrupt is enabled and the stack is not full, the program will jump to location 008H and begins execution.
- Location 00CH
This area is reserved for the 8-bit timer counter 1 interrupt service program. If a timer interrupt results from a timer counter 1 overflow, and if the interrupt is enabled and the stack is not full, the program will jump to location 00CH and begins execution.

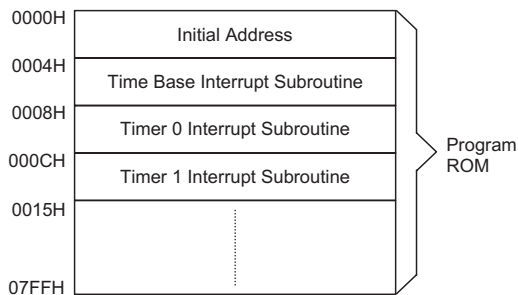

Program Memory

Table Location

Any location in the ROM space can be used as look up tables. The instructions TABRDC [m] (used for any bank) and TABRDL [m] (only used for last page of program ROM) transfer the contents of the lower-order byte to the specified data memory [m], and the higher-order byte to TBLH (08H). Only the destination of the lower-order byte in the table is well-defined. The higher-order bytes of the table word are transferred to the TBLH. The table higher-order byte register (TBLH) is read only.

The table pointer (TBLP) is a read/write register, which indicates the table location.

Stack Register – Stack

The stack register is a special part of the memory used to save the contents of the program counter (PC). This stack is organized into four levels. It is neither part of the data nor part of the program space, and cannot be read or written to. Its activated level is indexed by a stack pointer (SP) and cannot be read or written to. At a subroutine call or interrupt acknowledgment, the contents of the program counter are pushed onto the stack.

The program counter is restored to its previous value from the stack at the end of subroutine or interrupt routine, which is signaled by return instruction (RET or RETI). After a chip resets, SP will point to the top of the stack.

The interrupt request flag will be recorded but the acknowledgment will be inhibited when the stack is full and a non-masked interrupt takes place. After the stack pointer is decremented (by RET or RETI), the interrupt request will be serviced. This feature prevents stack overflow and allows programmers to use the structure more easily. In a similar case, if the stack is full and a "CALL" is subsequently executed, stack overflow occurs and the first entry is lost.

Instruction	Table Location										
	*10	*9	*8	*7	*6	*5	*4	*3	*2	*1	*0
TABRDC [m]	P10	P9	P8	@7	@6	@5	@4	@3	@2	@1	@0
TABRDL [m]	1	1	1	@7	@6	@5	@4	@3	@2	@1	@0

Table Location

Note: *10~*0: Current program ROM table

@7~@0: Write @7~@0 to TBLP pointer register

P10~P8: Bits of current program counter

Data Memory – RAM

The data memory is designed with 80×8 bits. The data memory is further divided into two functional groups, namely, special function registers (00H~2AH) and general purpose user data memory (30H~7FH). Although most of them can be read or be written to, some are read only.

The special function registers include an indirect addressing register (R0:00H), memory pointer register (MP0:01H), accumulator (ACC:05H), program counter lower-order byte register (PCL:06H), table pointer (TBLP:07H), table higher-order byte register (TBLH:08H), status register (STATUS:0AH), interrupt control register 0 (INTC:0BH), timer counter 0 (TMR0:0DH), timer counter 0 control register (TMR0C:0EH), timer counter 1 (TMR1L:10H), timer counter 1 control register (TMR1C:11H), I/O registers (PA:12H), I/O control registers (PAC:13H), voice ROM address latch0[21:0] (LATCH0H:18H, LATCH0M:19H, LATCH0L:1AH), time base control bit EBTI (INTC.1), PWM control register (PWMCR:26H), PWM output (PWMD:28H), voice ROM latch data register (LATCHD:2AH).

The general purpose data memory, addressed from 30H~7FH, is used for data and control information under instruction commands.

The areas in the RAM can directly handle the arithmetic, logic, increment, decrement and rotate operations. Except some dedicated bits, each bit in the RAM can be set and reset by "SET [m].i" and "CLR [m].i". They are also indirectly accessible through the Memory Pointer register 0 (MP0:01H).

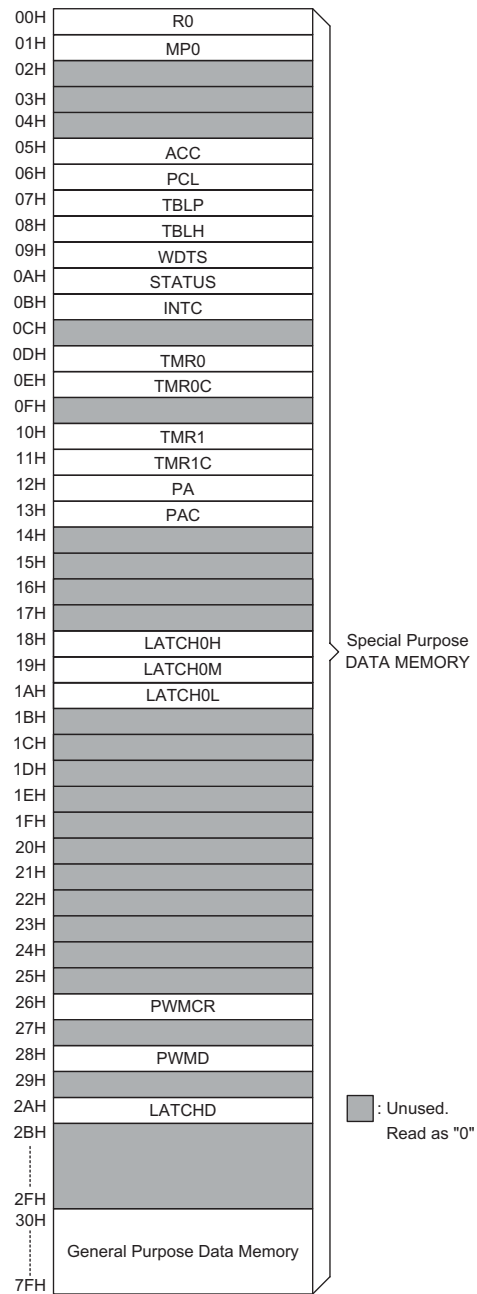

RAM Mapping

Address	RAM Mapping	Read/Write	Description
00H	R0	R/W	Indirect addressing register 0
01H	MP0	R/W	Memory pointer 0
05H	ACC	R/W	Accumulator
06H	PCL	R/W	Program counter lower-order byte address
07H	TBLP	R/W	Table pointer lower-order byte register
08H	TBLH	R	Table higher-order byte content register
09H	WDTs	R/W	Watchdog Timer option setting register

Address	RAM Mapping	Read/Write	Description
0AH	STATUS	R/W	Status register
0BH	INTC	R/W	Interrupt control register 0
0DH	TMR0	R/W	Timer counter 0 register
0EH	TMR0C	R/W	Timer counter 0 control register
10H	TMR1	R/W	Timer counter 1 register
11H	TMR1C	R/W	Timer counter 1 control register
12H	PA	R/W	Port A I/O data register
13H	PAC	R/W	Port A I/O control register
18H	LATCH0H	R/W	Voice ROM address latch 0 [A17, A16]
19H	LATCH0M	R/W	Voice ROM address latch 0 [A15~A8]
1AH	LATCH0L	R/W	Voice ROM address latch 0 [A7~A0]
26H	PWMCR	R/W	PWM control register
28H	PWMD	R/W	PWM output data D7~D0
2AH	LATCHD	R	Voice ROM data register
2BH~2FH	Unused		
30H~7FH	User data RAM	R/W	User data RAM

Note: R: Read only
W: Write only
R/W: Read/Write

Indirect Addressing Register

Location 00H is indirect addressing registers that are not physically implemented. Any read/write operation of [00H] accesses the RAM pointed to by MP0 (01H) respectively. Reading location 00H indirectly returns the result 00H. While, writing it indirectly leads to no operation.

Accumulator – ACC (05H)

The accumulator (ACC) is related to the ALU operations. It is also mapped to location 05H of the RAM and is capable of operating with immediate data. The data movement between two data memory locations must pass through the ACC.

Arithmetic and Logic Unit – ALU

This circuit performs 8-bit arithmetic and logic operations and provides the following functions:

- Arithmetic operations (ADD, ADC, SUB, SBC, DAA)
- Logic operations (AND, OR, XOR, CPL)
- Rotation (RL, RR, RLC, RRC)
- Increment and Decrement (INC, DEC)
- Branch decision (SZ, SNZ, SIZ, SDZ etc)

Status Register – STATUS (0AH)

This 8-bit STATUS register (0AH) consists of a zero flag (Z), carry flag (C), auxiliary carry flag (AC), overflow flag (OV), power down flag (PDF), watchdog time-out flag (TO). It also records the status information and controls the operation sequence.

Except the TO and PDF flags, bits in the status register can be altered by instructions similar to other registers. Data written into the status register does not alter the TO or PDF flags. Operations related to the status register, however, may yield different results from those intended. The TO and PDF flags can only be changed by a Watchdog Timer overflow, chip power-up, or clearing the Watchdog Timer and executing the "HALT" instruction. The Z, OV, AC, and C flags reflect the status of the latest operations.

On entering the interrupt sequence or executing the subroutine call, the status register will not be automatically pushed onto the stack. If the contents of the status is important, and if the subroutine is likely to corrupt the status register, the programmer should take precautions and save it properly.

Labels	Bits	Function
C	0	C is set if an operation results in a carry during an addition operation or if a borrow does not take place during a subtraction operation; otherwise C is cleared. C is also affected by a rotate through carry instruction.
AC	1	AC is set if an operation results in a carry out of the low nibbles in addition or no borrow from the high nibble into the low nibble in subtraction; otherwise AC is cleared.
Z	2	Z is set if the result of an arithmetic or logical operation is zero; otherwise Z is cleared.
OV	3	OV is set if an operation results in a carry into the highest-order bit but not a carry out of the highest-order bit, or vice versa; otherwise OV is cleared.
PDF	4	PDF is cleared by system power-up or executing the "CLR WDT" instruction. PDF is set by executing the "HALT" instruction.
TO	5	TO is cleared by system power-up or executing the "CLR WDT" or "HALT" instruction. TO is set by a WDT time-out.
—	6, 7	Unused bit, read as "0"

Status Register

Interrupts

The HT83XXX provides two 8-bit programmable timer interrupts, and a time base interrupt. The Interrupt Control registers (INTC:0BH) contain the interrupt control bits to set to enable/disable and the interrupt request flags.

Once an interrupt subroutine is serviced, all other interrupts will be blocked (by clearing the EMI bit). This scheme may prevent any further interrupt nesting. Other interrupt requests may happen during this interval but only the interrupt request flag is recorded. If a certain interrupt needs servicing within the service routine, the EMI bit and the corresponding INTC bit may be set to allow interrupt nesting. If the stack is full, the interrupt request will not be acknowledged, even if the related interrupt is enabled, until the SP is decremented. If immediate service is desired, the stack must be prevented from becoming full.

As an interrupt is serviced, a control transfer occurs by pushing the program counter onto the stack and then branching to subroutines at the specified location(s) in the program memory. Only the program counter is pushed onto the stack. The programmer must save the contents of the register or status register (STATUS) in advance if they are altered by an interrupt service program which corrupts the desired control sequence.

The Internal Timer Counter 0 Interrupt is initialized by setting the timer counter 0 interrupt request flag (TOF:bit 5 of INTC), caused by a timer counter 0 overflow. When the interrupt is enabled, and the stack is not full and the TOF bit is set, a subroutine call to location 08H will occur. The related interrupt request flag (TOF) will be reset and the EMI bit cleared to disable further interrupts.

The Internal Timer Counter 1 Interrupt is initialized by setting the timer counter 1 interrupt request flag (T1F:bit 6 of INTC), caused by a timer counter 1 overflow. When the interrupt is enabled, and the stack is not full and the

T1F bit is set, a subroutine call to location 0CH will occur. The related interrupt request flag (T1F) will be reset and the EMI bit cleared to disable further interrupts.

Time Base Interrupt is triggered by set INTC.1 (ETBI) which sets the related interrupt request flag (TBF:bit 4 of INTC). When the interrupt is enabled, and the stack is not full and the external interrupt is active, a subroutine call to location 04H will occur. The interrupt request flag (TBF) and EMI bits will be cleared to disable other interrupts.

During the execution of an interrupt subroutine, other interrupt acknowledgment are held until the RETI instruction is executed or the EMI bit and the related interrupt control bit are set to 1 (of course, if the stack is not full). To return from the interrupt subroutine, the RET or RETI instruction may be invoked. RETI will set the EMI bit to enable an interrupt service, but RET will not.

Interrupts occurring in the interval between the rising edges of two consecutive T2 pulses, will be serviced on the latter of the two T2 pulses, if the corresponding interrupts are enabled. In the case of simultaneous requests, the following table shows the priority that is applied. These can be masked by resetting the EMI bit.

The timer counter 0/1 interrupt request flag (TOF/T1F) which enables timer counter 0/1 control bit (ET0I/ET1I), the time base interrupt request flag (TBF) which enables time base control bit (ETTBI) from the interrupt control register (INTC:0BH) EMI, ETBI, ET0I, ET1I are used to control the enabling/disabling of interrupts. These bits prevent the requested interrupt begin serviced. Once the interrupt request flags (TOF, T1F, TBF) are set, they will remain in the INTC register until the interrupts are serviced or cleared by a software instruction.

It is recommended that application programs do not use CALL subroutines within an interrupt subroutine. Interrupts often occur in an unpredictable manner or need to be serviced immediately in some applications. If only

one stack is left and the interrupt enable is not well controlled, once a CALL subroutine is used in the interrupt subroutine will corrupt the original control sequence.

Register	Bit No.	Label	Function
INTC (0BH)	0	EMI	Controls the master (global) interrupt (1= enabled; 0= disabled)
	1	ETBI	Controls the time base interrupt (1= enabled; 0= disabled)
	2	ETOI	Controls the timer 0 interrupt (1= enabled; 0= disabled)
	3	ET1I	Controls the timer 1 interrupt (1= enabled; 0= disabled)
	4	TBF	Time base interrupt request flag (1= active; 0= inactive)
	5	T0F	Timer 0 request flag (1= active; 0= inactive)
	6	T1F	Timer 1 request flag (1= active; 0= inactive)
	7	—	Unused bit, read as "0"

INTC0 register

Interrupt Source	Priority	Vector
Time Base Interrupt	1	04H
Timer Counter 0 Overflow	2	08H
Timer Counter 1 Overflow	3	0CH

Oscillator Configuration

The HT83XXX provides RC oscillator circuit for the system clock. The signal is used for the system clock. The HALT mode stops the system oscillator to conserve power. If the RC oscillator is used, an external resistor between OSC1 and VSS is required, and the range of the resistance should be from 62kΩ to 100kΩ. The system clock, divided by 4. The RC oscillator provides the most cost effective solution. However, the frequency of the oscillation may vary with VDD, temperature, and the chip itself due to process variations. It is therefore not suitable for timing sensitive operations where accurate oscillator frequency is desired.

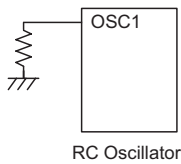

System Oscillator

Watchdog Timer – WDT

The WDT clock source is implemented by a dedicated RC oscillator (WDT oscillator) or instruction clock (system clock divided by 4), decided by mask options. This timer is designed to prevent a software malfunction or sequence jumping to an unknown location with unpredictable results. The Watchdog Timer can be disabled by mask option. If the Watchdog Timer is disabled, all the executions related to the WDT result in no operation.

Once the internal WDT oscillator (RC oscillator with period 78μs normally) is selected, it is first divided by 256 (8-stages) to get the nominal time-out period of approximately 20ms. This time-out period may vary with temperature, VDD and process variations. By invoking the WDT prescaler, longer time-out period can be realized. Writing data to WS2, WS1, WS0 (bit 2,1,0 of WDTS(09H)) can give different time-out period.

If WS2, WS1, WS0 all equal to 1, the division ratio is up to 1:128, and the maximum time-out period is 2.6 seconds.

If the device operates in a noisy environment, using the on-chip RC oscillator (WDT OSC) is strongly recommended, since the HALT will stop the system clock.

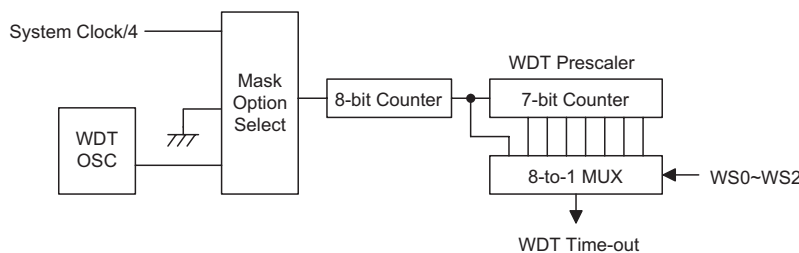

Watchdog Timer

The WDT overflow under normal operation will initialize a "chip reset" and set the status bit "TO". Whereas in the HALT mode, the overflow will initialize a "warm re-set" only the PC and SP are reset to zero. To clear the contents of the WDT (including the WDT prescaler),

three methods are adopted; external reset (external reset (a low level to RES), software instructions, or a HALT instruction. The software instruction is "CLR WDT" and execution of the "CLR WDT" instruction will clear the WDT.

WS7	WS6	WS5	WS4	WS3	WS2	WS1	WS0	Division Ratio
—	—	—	—	—	0	0	0	1:1
—	—	—	—	—	0	0	1	1:2
—	—	—	—	—	0	1	0	1:4
—	—	—	—	—	0	1	1	1:8
—	—	—	—	—	1	0	0	1:16
—	—	—	—	—	1	0	1	1:32
—	—	—	—	—	1	1	0	1:64
—	—	—	—	—	1	1	1	1:128

WDTS Register

Power Down – HALT

The HALT mode is initialized by a HALT instruction and results in the following:

- The system oscillator will be turned off but the WDT oscillator keeps running (if the WDT oscillator is selected).
- The contents of the on chip RAM and registers remain unchanged.
- WDT and WDT prescaler will be cleared and recount again.
- All I/O ports maintain their original status.
- The PDF flag is set and the TO flag is cleared.

The system can leave the HALT mode by means of an external reset, an interrupt, an external falling edge signal on port A or a WDT overflow. An external reset causes a device initialization and the WDT overflow performs a "warm reset". By examining the TO and PDF flags, the reason for the chip reset can be determined. The PDF flag is cleared when the system powers-up or executes the "CLR WDT" instruction, and is set when the "HALT" instruction is executed. The TO flag is set if a WDT time-out occurs, and causes a wake-up that only resets the PC and SP. The other maintain their original status.

The port A wake-up and interrupt methods can be considered as a continuation of normal execution. Each bit in port A can be independently selected to wake up the device by mask option. Awakening from an I/O port stimulus, the program will resume execution of the next instruction. If awakening from an interrupt, two sequence may occur. If the related interrupt is disabled or the interrupt is enabled by the stack is full, the program will resume execution at the next instruction. If the interrupt is enabled and the stack is not full, the regular interrupt response takes place.

Once a wake-up event occurs, it takes 1024 system clock period to resume normal operation. In other words, a dummy cycle period will be inserted after a wake-up. If the wake-up results from an interrupt acknowledge, the actual interrupt subroutine will be delayed by one more cycle. If the wake-up results in next instruction execution, this will be executed immediately after a dummy period is finished. If an interrupt request flag is set to "1" before entering the HALT mode, the wake-up function of the related interrupt will be disabled. To minimize power consumption, all I/O pins should be carefully managed before entering the HALT status.

Reset

There are 3 ways in which a reset can occur:

- \overline{RES} reset during normal operation
- \overline{RES} reset during HALT
- WDT time-out reset during normal operation

The WDT time-out during HALT is different from other chip reset conditions, since it can perform a "warm reset" that resets only the PC and SP, leaving the other circuits in their original state. Some registers remain unchanged during any other reset conditions. Most registers are reset to their "initial condition" when the reset conditions are met. By examining the PDF flag and TO flag, the program can distinguish between different "chip resets".

TO	PDF	RESET Conditions
0	0	\overline{RES} reset during power-up
u	u	\overline{RES} reset during normal operation
0	1	\overline{RES} wake-up HALT
1	u	WDT time-out during normal operation
1	1	WDT wake-up HALT

Note: "u" stands for "unchanged"

To guarantee that the system oscillator has started and stabilized, the SST (System Start-up Timer) provides an extra-delay of 1024 system clock pulses after a system power up or when awakening from a HALT state.

When a system power up occurs, the SST delay is added during the reset period. But when the reset comes from the \overline{RES} pin, the SST delay is disabled. Any wake-up from HALT will enable the SST delay.

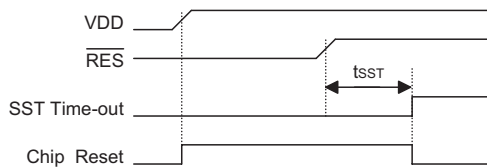

Reset Timing Chart

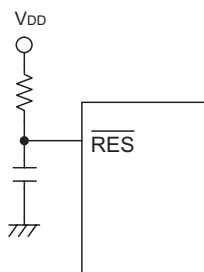

Reset Circuit

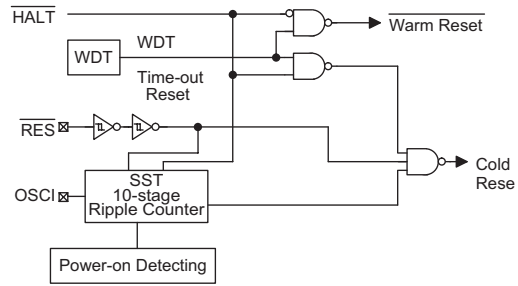

Reset Configuration

The functional unit chip reset status are shown below.

PC	000H
Interrupt	Disable
Prescaler	Clear
WDT	Clear. After master reset, WDT begins counting
Timer counter	Off
Input/output ports	Input mode
SP	Points to the top of the stack

Timer Counter 0/1

The TMR0/TMR1 is internal clock source only, i.e. (TM1, TM0)=(1,0). There is a 3-bit prescaler (TMRS2, TMRS1, TMRS0) which defines different division ratio of TMR0/TMR1's clock source.

Label	Bits	Function
TMRS2, TMRS1, TMRS0	0~2	Defines the operating clock source (TMRS2, TMRS1, TMRS0) 000: clock source/2 001: clock source/4 010: clock source/8 011: clock source/16 100: clock source/32 101: clock source/64 110: clock source/128 111: clock source/256
TE	3	Defines the TMR0/TMR1 active edge of timer counter
TON	4	Enable/disable timer counting (0=disabled; 1=enabled)
—	5	Unused bit, read as "0"
TM0, TM1	6 7	Defines the operating mode (TM1, TM0)

TMR0C/TMR1C Register

- Note:
- TMR0C/TMR1C bit 3 always write "0"
 - TMR0C/TMR1C bit 5 always write "0"
 - TMR0C/TMR1C bit 6 always write "1"
 - TMR0C/TMR1C bit 7 always write "0"

The TMR0C is the timer counter 0 control register, which defines the timer counter 0 options. The timer counter 1 has the same options as the timer counter 0 and is defined by TMR1C.

To enable the counting operation, the Timer ON bit (TON; bit 4 of TMR0C/TMR1C) should be set to 1. The overflow of the timer counter is one of the wake-up sources. No matter what the operation mode is, writing a 0 to ET0I/ET1I can disable the corresponding interrupt service.

The TMR0/1 is internal clock source only. There is a 3-bit prescaler (TMRS2, TMRS1, TMRS0) which defines different division ratio of TMR0/1's clock source.

Time Base

The time base enables the counting operation by INTC.1 (ETBI) bit. The overflow to interrupt as set INTC.1. The time base is internal clock source only. Time base of 1ms to overflow as system clock is 4MHz. Time base of 0.5ms to overflow as system clock is 8MHz.

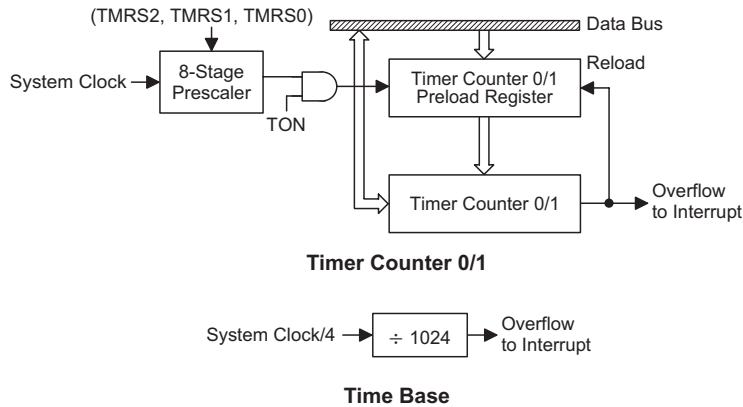

The registers states are summarized in the following table.

Register	Reset (Power On)	WDT Time-out (Normal Operation)	RES Reset (Normal Operation)	RES Reset (HALT)	WDT Time-out (HALT)
PC	0000H	0000H	0000H	0000H	0000H
MP0	xxxx xxxx	uuuu uuuu	uuuu uuuu	uuuu uuuu	uuuu uuuu
ACC	xxxx xxxx	uuuu uuuu	uuuu uuuu	uuuu uuuu	uuuu uuuu
TBLP	xxxx xxxx	uuuu uuuu	uuuu uuuu	uuuu uuuu	uuuu uuuu
TBLH	xxxx xxxx	uuuu uuuu	uuuu uuuu	uuuu uuuu	uuuu uuuu
WDTS	0000 0111	0000 0111	0000 0111	0000 0111	uuuu uuuu
STATUS	--00 xxxx	--1u uuuu	--uu uuuu	--01 uuuu	--11 uuuu
INTC	-000 0000	-000 0000	-000 0000	-000 0000	-uuu uuuu
TMR0	xxxx xxxx	uuuu uuuu	uuuu uuuu	uuuu uuuu	uuuu uuuu
TMR0C	00-0 1---	00-0 1---	00-0 1---	00-0 1---	uu-u u---
TMR1	xxxx xxxx	uuuu uuuu	uuuu uuuu	uuuu uuuu	uuuu uuuu
TMR1C	00-0 1---	00-0 1---	00-0 1---	00-0 1---	uu-u u---
LATCH0H	---- --xx	---- --uu	---- --uu	---- --uu	---- --uu
LATCH0M	xxxx xxxx	uuuu uuuu	uuuu uuuu	uuuu uuuu	uuuu uuuu
LATCH0L	xxxx xxxx	uuuu uuuu	uuuu uuuu	uuuu uuuu	uuuu uuuu
PA	1111 1111	1111 1111	1111 1111	1111 1111	uuuu uuuu
PAC	1111 1111	1111 1111	1111 1111	1111 1111	uuuu uuuu
PWMCR	-00- 00-0	-uu- uu-u	-uu- uu-u	-uu- uu-u	-uu- uu-u
PWMD	xxxx xxxx	uuuu uuuu	uuuu uuuu	uuuu uuuu	uuuu uuuu
LATCHD	xxxx xxxx	uuuu uuuu	uuuu uuuu	uuuu uuuu	uuuu uuuu

Note: "u" means "unchanged"; "x" means "unknown"; "--" means "undefined"

Input/Output Ports

There are 8 bidirectional input/output lines in the microcontroller, labeled from PA, which are mapped to the data memory of [12H] respectively. All of these I/O ports can be used for input and output operations. For input operation, these ports are non-latching, that is, the inputs must be ready at the T2 rising edge of instruction "MOV A, [m]" (m=12H). For output operation, all the data is latched and remains unchanged until the output latch is rewritten.

Each I/O line has its own control register (PAC) to control the input/output configuration. With this control register, CMOS output or Schmitt trigger input with or without pull-high resistor structures can be reconfigured dynamically under software control. To function as an input, the corresponding latch of the control register must write "1". The input source also depends on the control register. If the control register bit is "1", the input will read the pad state. If the control register bit is "0", the contents of the latches will move to the internal bus. The latter is possible in the "read-modify-write" instruction.

For output function, CMOS is the only configuration. These control registers are mapped to locations 13H.

After a chip reset, these input/output lines remain at high levels or floating state (dependent on pull-high options). Each bit of these input/output latches can be set or cleared by "SET [m].i" and "CLR [m].i" (m=12H) instructions.

Some instructions first input data and then follow the output operations. For example, "SET [m].i", "CLR [m].i", "CPL [m]", "CPLA [m]" read the entire port states into the CPU, execute the defined operations (bit-operation), and then write the results back to the latches or the accumulator.

Each line of port A has the capability of waking-up the device. The wake-up capability of port A is determined by mask option. There is a pull-high option available for all I/O lines. Once the pull-high option is selected, all I/O lines have pull-high resistors. Otherwise, the pull-high resistors are absent. It should be noted that a non-pull-high I/O line operating in input mode will cause a floating state.

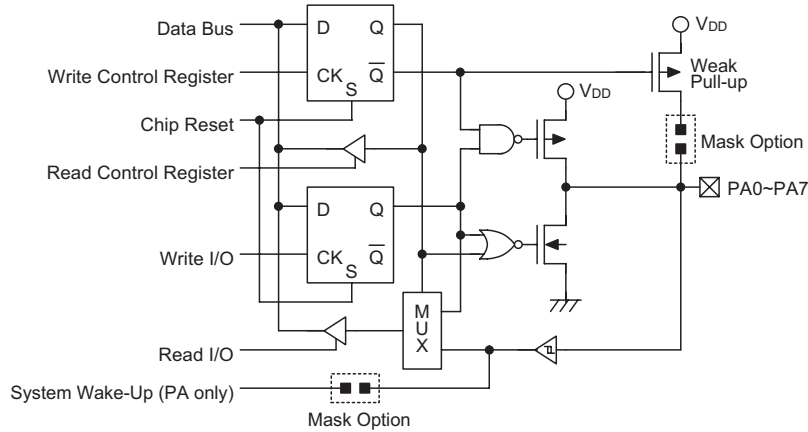

Input/Output Ports

Audio Output – PWMD (28H)

The HT83XXX provides one 8-bit PWM interface for driving an external 8Ω speaker. The programmer must write the voice data to register PWMD (28H)

Pulse Width Modulation Control Register – PWMCR (26H)

Bit 7	Bit 6 (R/W)	Bit 5 (R/W)	Bit 4	Bit 3 (R/W)	Bit 2 (R/W)	Bit 1	Bit 0 (R/W)
—	P1	P0	—	Single_PWM	VROMC	—	PWMC

PWMC: Start bit of PWM output

- PWM start counter: 0 to 1
- PWM stop counter: 1 to 0

After waiting one cycle end , stop the PWM counter and keep in low signal

VROMC: Enable voice ROM power circuit (1=enable; 0=disable)

Single_PWM: Driving PWM signal only by PWM1 port. (1=enable; 0=disable)

The HT83xxx provides an 8-bit (bit 7 is a sign bit, if Single_PWM = 0) PWM interface. The PWM provides two pad outputs: PWM1, PWM2 which can directly drive a piezo or a 8Ω speaker without adding any external element (green mode), or using only port PWM1 (Set Single_PWM = 1) to drive piezo or a 8Ω speaker with external element.

When Setting Single_PWM = 1, choose voice data7~data1 as the output data (no sign bit on it).

Setting data to P0 and P1 can generate various sampling rates (5kHz/6kHz/8kHz):

P1	P0	Sampling Rate	Carrier frequency	Preload Times	PWM Code Range
0	0	5kHz	30kHz	6	1~127
0	1	6kHz	30kHz	5	1~127
1	0	8kHz	32kHz	4	1~124
—	—	X	X	X	X

If the sign bit is 0, then the signal is output to PWM1 and the PWM2 will get a GND level voltage after setting start bit to 1. If the sign bit is 1, then the signal is output to

PWM2 and the PWM1 will get a GND level voltage after setting start bit to 1.

PWM □output Initial low level , and stop in low level

If PWMC from low to high then start PWM output and 5kHz/6kHz/8kHz latch new data , if no update then keep the old value.

If PWMC from high to low, in duty end, stop PWM output and stop the counter.

Voice ROM Data Address Latch Counter

The voice ROM data address latch counter is the handshaking between the microcontroller and voice ROM, where the voice codes are stored. One 8-bit of voice ROM data will be addressed by setting 18-bit address latch counter LATCH0H/LATCH0M/LATCH0L. After the 8-bit voice ROM data is addressed, a few instruction cycles (4μs at least) will be generated to latch the voice ROM data, then the microcontroller can read the voice data from LATCHD (2AH).

Example: Read an 8-bit voice ROM data which is located at address 000007H by address latch 0

```

set [26H].2 ; Enable voice ROM circuit
mov A, 07H ;
mov LATCH0L, A ; Set LATCH0L to 07H
mov A, 00H ;
mov LATCH0M, A ; Set LATCH0M to 00H
mov A, 00H ;
mov LATCH0H, A ; Set LATCH0H to 00H
call Delay Time ; Delay a short period of time
mov A, LATCHD ; Get voice data at 000007H
    
```

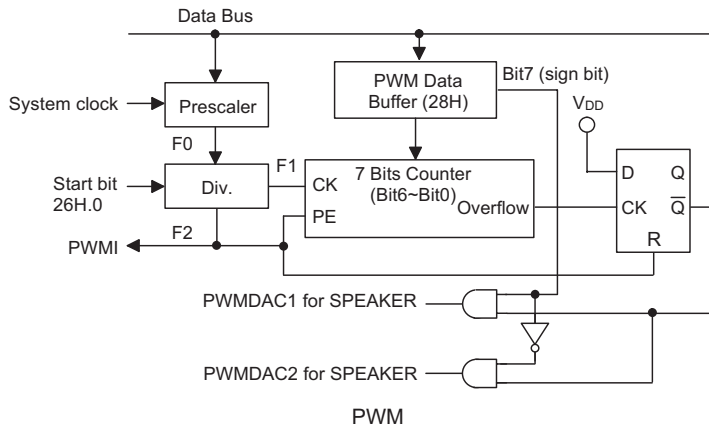

Mask Option

Mask Option	Description
PA Wake-up	Enable or disable PA wake-up function
Watchdog Timer (WDT)	Enable or disable WDT function WDT clock source is from WDTOSC or T1
PA Pull-high	Enable or disable PA pull-high

f_{osc} - R_{osc} Table ($V_{DD}=5V$)

f_{osc}	R_{osc}
4MHz±10%	100kΩ
6MHz±10%	75kΩ
8MHz±10%	62kΩ

Application Circuits

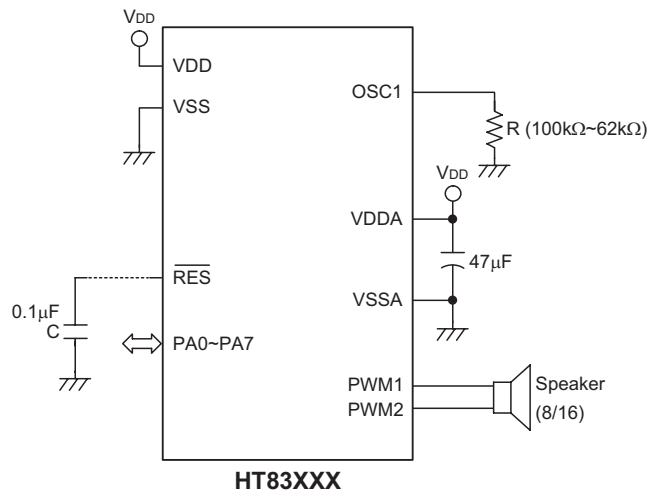

Single PWM Mode

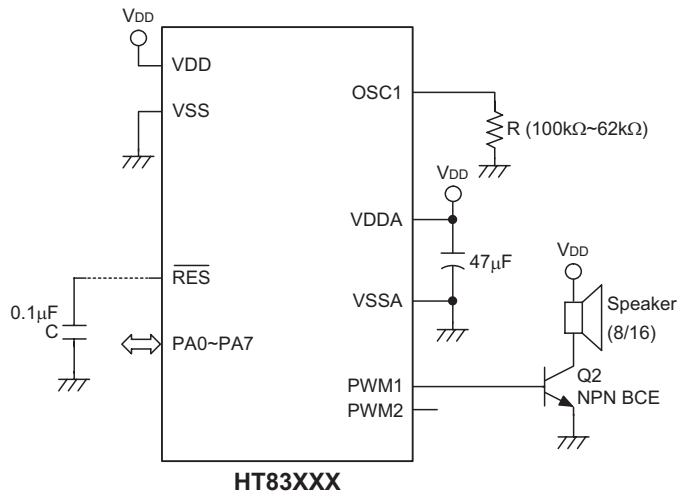

Note: * For normal application, a capacitor C is not necessary. However, if you want to extend the reset time, a 0.1µF capacitor can be placed on the \overline{RES} pin.

Package Information

32-pin DIP (600mil) Outline Dimensions

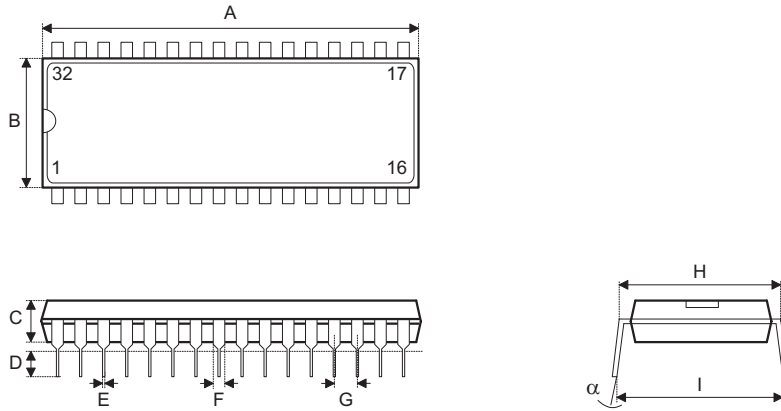

Symbol	Dimensions in mil		
	Min.	Nom.	Max.
A	1635	—	1665
B	535	—	555
C	145	—	155
D	125	—	145
E	16	—	20
F	50	—	70
G	—	100	—
H	595	—	615
I	635	—	670
α	0°	—	15°

Holtek Semiconductor Inc. (Headquarters)

No.3, Creation Rd. II, Science Park, Hsinchu, Taiwan
Tel: 886-3-563-1999
Fax: 886-3-563-1189
<http://www.holtek.com.tw>

Holtek Semiconductor Inc. (Taipei Sales Office)

4F-2, No. 3-2, YuanQu St., Nankang Software Park, Taipei 115, Taiwan
Tel: 886-2-2655-7070
Fax: 886-2-2655-7373
Fax: 886-2-2655-7383 (International sales hotline)

Holtek Semiconductor Inc. (Shanghai Sales Office)

7th Floor, Building 2, No.889, Yi Shan Rd., Shanghai, China 200233
Tel: 021-6485-5560
Fax: 021-6485-0313
<http://www.holtek.com.cn>

Holtek Semiconductor Inc. (Shenzhen Sales Office)

43F, SEG Plaza, Shen Nan Zhong Road, Shenzhen, China 518031
Tel: 0755-8346-5589
Fax: 0755-8346-5590
ISDN: 0755-8346-5591

Holtek Semiconductor Inc. (Beijing Sales Office)

Suite 1721, Jinyu Tower, A129 West Xuan Wu Men Street, Xicheng District, Beijing, China 100031
Tel: 010-6641-0030, 6641-7751, 6641-7752
Fax: 010-6641-0125

Holmate Semiconductor, Inc. (North America Sales Office)

46712 Fremont Blvd., Fremont, CA 94538
Tel: 510-252-9880
Fax: 510-252-9885
<http://www.holmate.com>

Copyright © 2003 by HOLTEK SEMICONDUCTOR INC.

The information appearing in this Data Sheet is believed to be accurate at the time of publication. However, Holtek assumes no responsibility arising from the use of the specifications described. The applications mentioned herein are used solely for the purpose of illustration and Holtek makes no warranty or representation that such applications will be suitable without further modification, nor recommends the use of its products for application that may present a risk to human life due to malfunction or otherwise. Holtek's products are not authorized for use as critical components in life support devices or systems. Holtek reserves the right to alter its products without prior notification. For the most up-to-date information, please visit our web site at <http://www.holtek.com.tw>.