

# REFERENCE DESIGN

International Rectifier • 233 Kansas Street El Segundo CA 90245 USA

## Technical Specifications

1. DC Input:  $V=36-72V$ ,  $I= 1.0A$  max
2. Inrush Current: 4A max
3. Efficiency: Typical 75% when measured at maximum load high line (73% at low line)
4. Output Characteristics

Nominal Ouput Voltage	Load Range		Regulation (V)
	Min	Max	
5V	0A	5A	4.75V ~ 5.25V

5. Turn On Delay: 300msec @ 36V full load
6. Hold-Up Time: 3msec (48Vin Full load) / 2ms (36Vin Full load)
7. Short Circuit Protection: Yes
- 8: Output Rise Time: 8ms max (10-90%)
- 9: Over Voltage Protection: Yes
- 10: Switching Frequency: 85 -425kHz

## Relevant Technical Documents

- AN1018a - Using the IR40xx Series SMPS ICs
- AN1024a - Flyback transformer design for the IR40xx series
- IRIS4007(K) - Datasheet

## Circuit Description

The IRISMPS2 reference design is a complete tested power supply circuit. It is designed for a 36-72V DC line input and will provide a 5V, 5A full load DC output.

The design uses a flyback converter topology, with an IRIS4007K as the main switch and control device. The initial startup current for the IRIS4007K is provided by a dropper resistor from the DC bus. Once the circuit is started the Vcc power for the IRIS4007K comes from the bias winding of the main transformer. The primary current control circuit consists of a current sensing resistor which feeds a voltage proportional to the transformer primary current into the feedback (FB) pin of the IRIS4007K. The secondary voltage control loop uses a zener diode as the reference and an optocoupler to feedback the information across the transformer isolation boundary back to the control circuit of the IRIS4007K.

## Test Circuit Set-up

The circuit is designed for a 36-72V DC line input. To effectively test and evaluate this circuit it is recommended that a DC power supply with a 100V range is used that is capable of supplying 5A. The DC input power is applied to the pins at P1(+) and P4(gnd) marked on the board.

For the output the best load to use is an electronic load which will allow easy changes in the output load, e.g. something like a Chroma 63102. Another simple alternative is to use a High power resistor for the load.

## Circuit Operation

The front end of the circuit consists of an EMI Filter. At power up the DC voltage is applied to the top of the transformer, and the top of resistor R3. R3 allows about 450uA of quiescent current to flow which charges the Vcc capacitor C9. When the voltage at the Vcc pin of the IRIS4007K reaches the positive undervoltage lockout threshold ( $V_{CCUV+}$ ), the IRIS4007K starts to operate and will turn on the internal FET. Now the DC bus voltage is applied across the transformer primary winding, the FET and the current sense resistor R10. The current through the transformer primary, the FET and the current sense resistors will start to ramp up. The rate of the ramp is dependent on the DC bus voltage. The current ramps until the voltage across R10 reaches the Vth1 of the IRIS4007K (0.73V typ). During this time there is no current flowing in either the bias winding or the output winding, because this is blocked by the diodes D1 and D4 respectively.

At the point when the voltage across R10 reaches Vth1 this activates a comparator in the IRIS4007K and the internal FET is switched off. Now the energy stored in the transformer causes the voltage at the Drain connected end of the transformer to rise, and as a result the voltage at the bias winding and the output winding changes from negative to positive. The output rectifiers now conduct and the energy is transferred to the output and the bias winding. If there is a fixed full current load on the output it will take a number of cycles for the output voltage to rise to the required level, and also it will take a few cycles for the bias winding to begin supplying power to the Vcc pin of the IRIS4007K. Until this happens, C9 holds the voltage above the undervoltage lockout level ( $V_{CCUV-}$ ) to make sure the circuit does not drop out. During this time the circuit cannot create enough voltage signal through the delay circuit to activate the quasi-resonant operation, so the circuit operates with a fixed off time of 50us (this is the pulse ratio control mode or PRC mode).

Once the the output capacitors C5/C6/C13 and the Vcc capacitor C6 are fully charged, the complete quasi-resonant signal is passed through the delay circuit D5/R7/D6 to the feedback (FB) pin. This will give a voltage above the Vth2 threshold of the IRIS4007K, and this activates the quasi-resonant operation, holding the internal FET off until all the energy is transferred from the primary side of the transformer to the secondary and bias outputs. When all the energy is transferred, the quasi-resonant signal at the FB pin will start to fall until it can no longer supply the 1.35mA required by the IRIS4007K internal latch, and the FET is turned back

on. This is also the lowest point of the resonant voltage at the drain pin of the IRIS4007K, so results in reduced switching losses.

If the DC input voltage changes but the load stays constant, the primary current ramp will now be steeper resulting in a shorter ON time, but still the same off time as it still takes the same amount of time to transfer the same energy to the output. The reduced ON time leads to a higher operating frequency.

If the DC input voltage remains constant, but the load is reduced, the secondary side voltage monitoring circuit (ISO1A/R5/D3) will see an increase in the voltage, as the circuit is still passing the same energy to the secondary side, but less current is being drawn. This causes the zener diode D3 to conduct, which leads to a current flow in the optocoupler ISO1A, which gets passed across the transformer boundary to the phototransistor part of the optocoupler ISO1B. This in turn creates a voltage drop across R9, generating an offset voltage at the FB pin which reduces the current required through the current sense resistor R10 needed to reach a voltage of 0.73Vtyp (Vth1 threshold) at the FB pin, and hence less energy is put into the transformer, reducing both the ON time and the OFF time.

### Circuit Waveforms

The following plots show waveforms taken from the circuit under various stated conditions

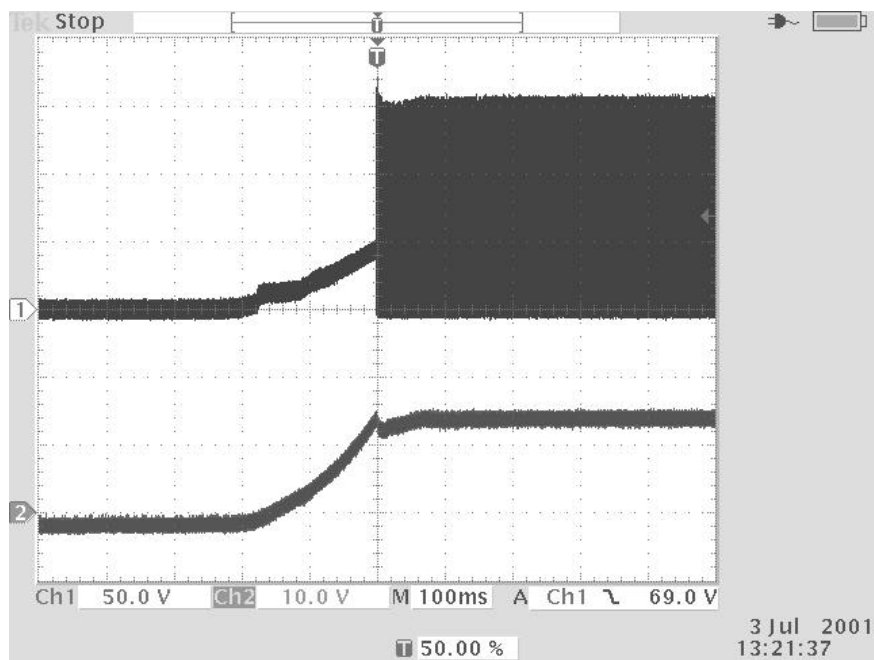

Fig 1) Drain (D) voltage of IRIS4007K (CH1) and Vcc voltage (CH2) at start-up

Fig 1) shows the drain voltage of the IRIS4007K and the Vcc voltage during start-up with full load output with a 48VDC input. Note the small dip in the Vcc voltage as the circuit starts to operate, and also the reflected voltage at the drain due from the output, raising the drain voltage above the DC bus.

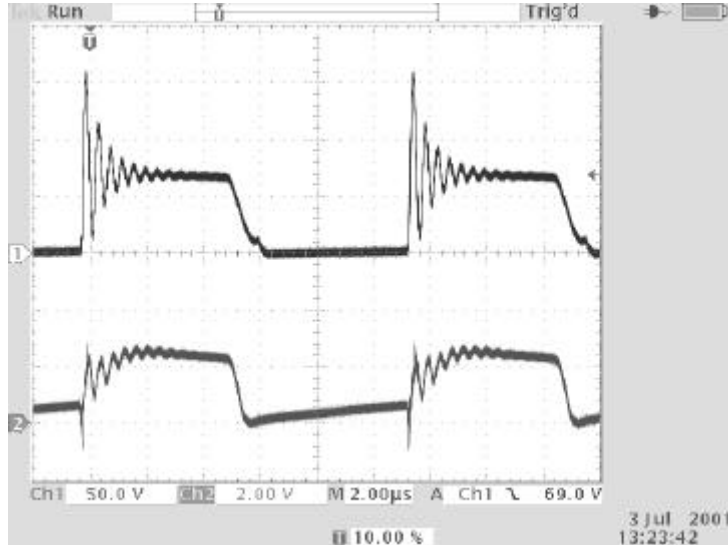

Fig 2) Drain (D) voltage of IRIS4007K (CH1) and the FB pin voltage (CH2) at 36VDC in/Full load output

Fig 2) shows the drain voltage and the feedback pin (FB) voltage. In this case the quasi-resonant signal swings all the way to near zero volts at the drain before the FET is turned on, and hence under these conditions the circuit turns the FET on with near zero voltage switching, due to the quasi-resonant switching. The FB pin signal shows the current ramp when the FET is on (when the drain voltage is low), and the resonant signal being passed back during the FET off time.

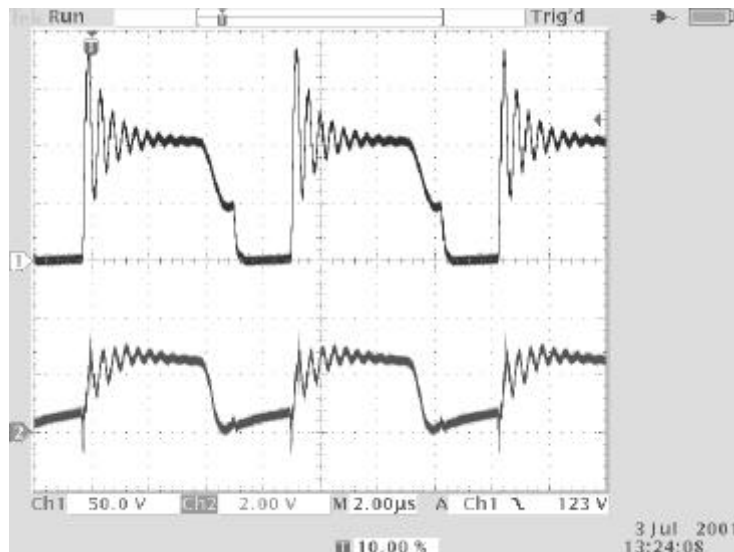

Fig 3) Drain (D) voltage of IRIS4007K (CH1) and the FB pin voltage (CH2) at 72VDC in/Full load output

Fig 3) shows the same waveforms as in fig 2) again with a full load output, but this time with a 72VDC input. Note that the operating frequency has now increased, and the effect of the quasi-resonant switching is now more pronounced. This is evident by the quarter sine wave nature of the falling edge of the drain waveform, at the bottom of which the FET is turned on, ensuring that it is turned on at the minimum possible voltage to reduce the switching losses. Note also the steeper ramp in the FB pin voltage when the FET is on which results in a shorter on time.

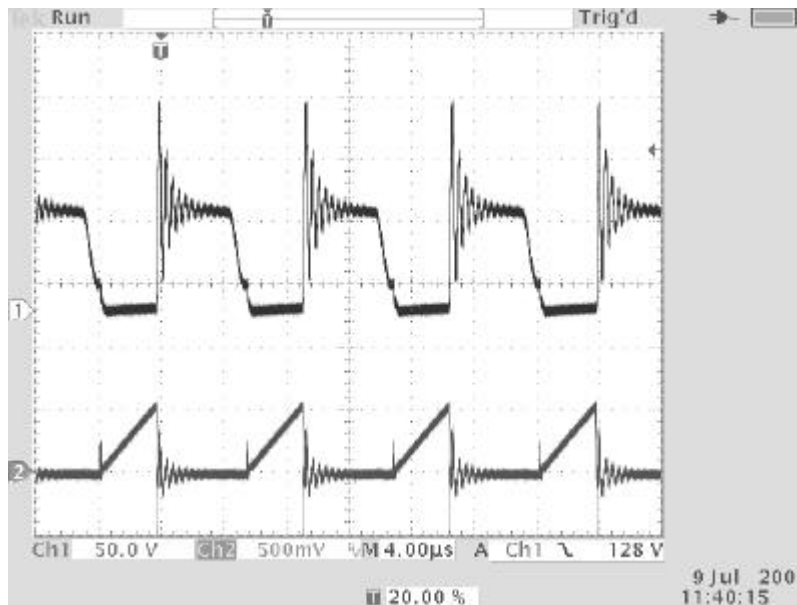

Fig 4) Drain (D) voltage of IRIS4007K (CH1) and the source(S) pin voltage (CH2) at 48VDC in/Full load output

Fig 4) shows the waveforms for a 48V input and full load output, but this time it show the Source (S) pin voltage with the drain voltage showing the effect of the primary current ramp, which is seen as a voltage generated across the current sense resistor R10. Note that this waveform shows some noise on the source pin voltage which is smoothed out by the RC filter comprising R9 and C12. The initial voltage spike at the start of the ramp is a result of discharging the quasi-resonant capacitor C5 and the primary winding capacitance of the transformer.

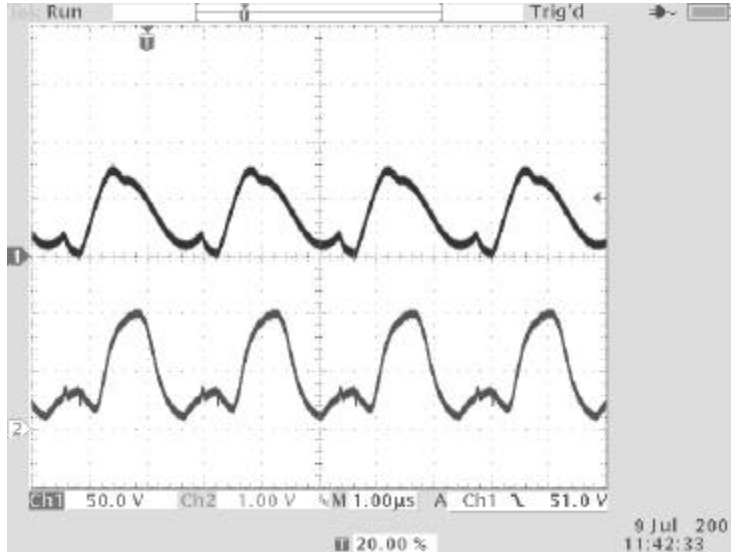

Fig 5) Drain (D) voltage of IRIS4007K(CH1) and the FB pin voltage(CH2) at 36VDC in/0.1A load output

Fig 5) again shows the drain and FB pin voltages, but this time with a 36VDC and a light load condition of 0.1A (0.5W output power). Again the quasi-resonant effect can be seen by the quarter wave signal on the drain pin and also at the FB pin. Note the very short on time, and the fact that the current ramp voltage at the FB pin does not start from zero, this is due to the offset voltage generated from the voltage feedback loop across R8.

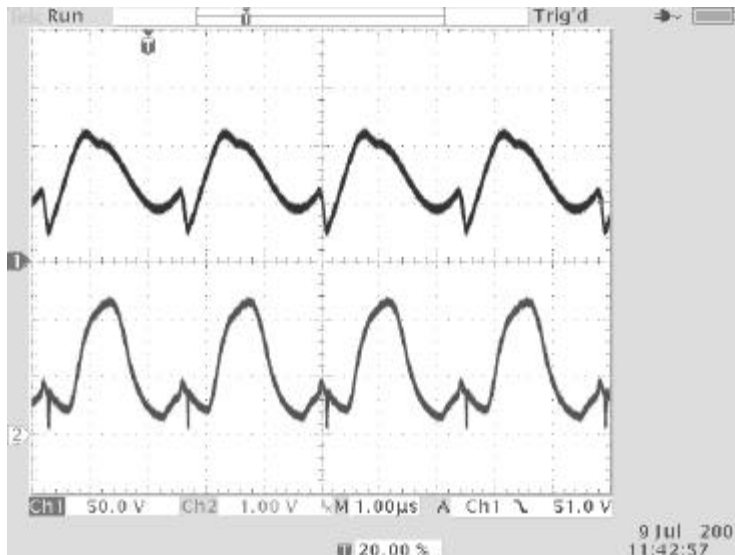
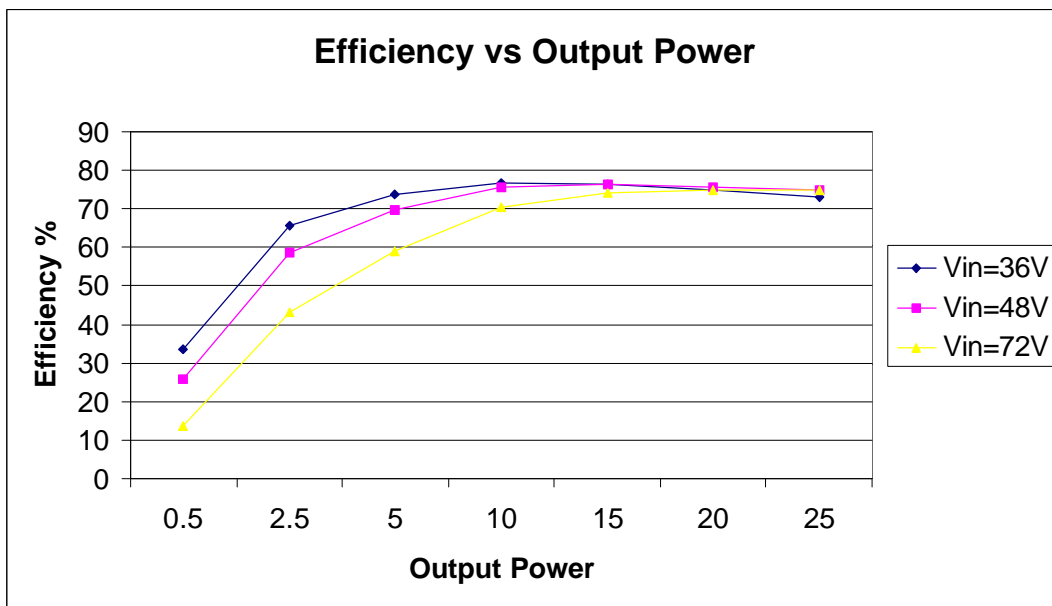
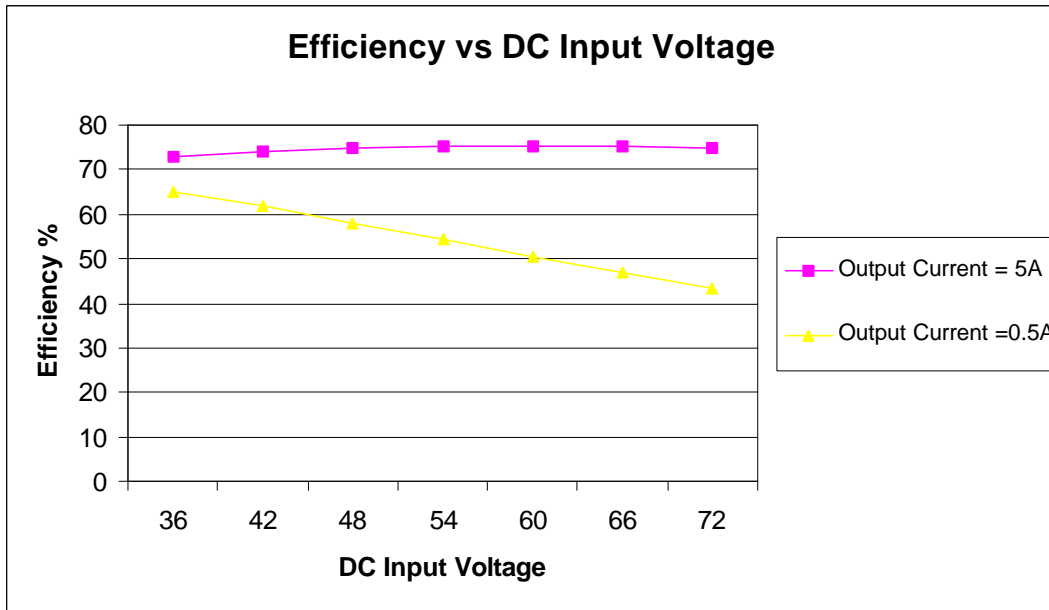

Fig 6) Drain (D) voltage of IRIS4011 (CH1) and the FB pin voltage (CH2) at 230VAC in/0.1A load output

Fig 6) shows the same details as in fig 5), but at 72VDC input, in this case you can see the on time is very short as it takes very little time to get the energy required into the transformer.

**Efficiency**



<b>IRISMPS1 48/5V 25W Converter B.O.M.</b>	
<b>ID</b>	<b>Description</b>
R1	16k 5% 1206 1/8W
R2	75R 5% 0805 1/10W
R3	18k 5% 1206 1/8W
R4	75R 5% 0805 1/10W
R5	0R 5% 0805 1/8W
R6	100R 5% 0805 1/10W
R7	2.0K 5% 0805 1/10W
R8	5.1K 5% 0805 1/10W
R9	680R 5% 0805 1/10W
R10	0.15R 5%1206 1/8W
C1	22uF 100V Electrolytic Capacitor
C2	470pF 0805 50V cermaic capacitor
C3	1nF 200V 0805 ceramic capacitor
C4	0.1uF 100V ceramic capacitor
C5	1000uF 25V Electrolytic Capacitor
C6	1000uF 25V Electrolytic Capacitor
C7	330uF 6.3V Electrolytic Capacitor
C8	2200pF 500V ceramic capacitor
C9	10uF 35V Electrolytic Capacitor
C10	0.1uF 50V 0805 ceramic capacitor
C11	0805 capacitor
C12	470pF 0805 50V cermaic capacitor
C13	1000uF 25V Electrolytic Capacitor
D1	30A 30V Schottky Diode
D2	Ultrafast recovery 1A 200V Diode UF1003
D3	3.9V Zener diode 500mW
D4	SM 1N4148 Diode
D5	SM 1N4148 Diode
D6	SM 1N4148 Diode
D7	SM 1N4148 Diode
HS1, HS2	Plug-in heatsinks for TO-200
ISO1	Optocoupler
U1	IR4007K 200V ISMPS IC
T1	Custom - Precision Inc
L1	1.5uH Inductor
L2	1.5uH Inductor



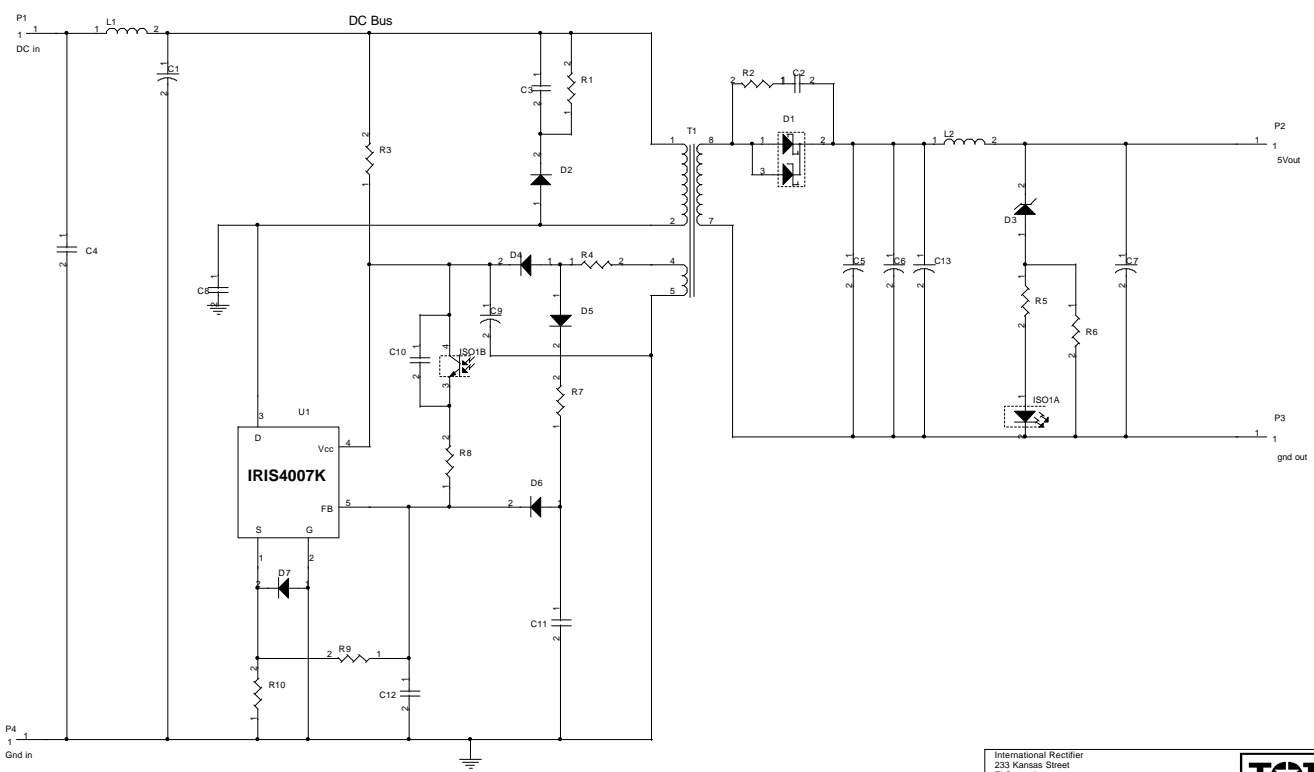

International Rectifier 233 Kansas Street El Segundo CA 90245		
		
Size	Title	Rev
B	IRISMP51 Reference Design	1.1
Filename		
Date:	Wednesday, June 06, 2001	Sheet 1 of 1

**Board Layout - Component Side**

