

Quad multifunction voltage regulator for car radio

Features

- 4 regulators:
 - 10 V (40 mA) low dropout
 - 8.5 V (175 mA)
 - 5 V (650 mA)
 - 5 V (100 mA) standby
- 3 high side drivers:
 - 2 A (HSD1)
 - 0.3 A (HSD2 & HSD3)
- No external charge pump capacitors are required
- Standby mode controlled by 3 input pins:
 - EN1 for REG1, REG2, REG3 and HSD1
 - EN2 for HSD2
 - EN3 for HSD3
- Individual thermal shutdown
- Logic outputs for supply undervoltage:
 - LVWARN
 - Reset
- Independent current limiting
- Overvoltage shutdown
- Short circuit protection
- Load dump protection and overvoltage
- Shutdown

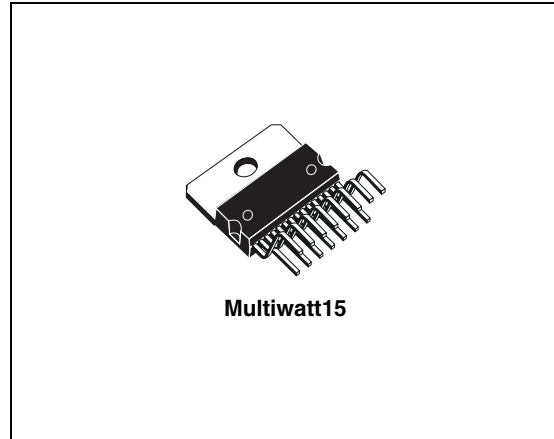

Description

L4954 is a quad output voltage regulator and a three output high side driver.

The IC includes monitoring circuitry to warn the microprocessor of a low voltage condition: the LVWarn, output, sensing the slow dropping of STCAP pins voltage, gives the microprocessor time to store data.

A reset output is generated at REG4's decay.

External protection must be provided for reverse battery protection.

Table 1. Device summary

Order code	Package	Packing
L4954	Multiwatt15	Tube

Contents

1	Block and pins connection diagrams	5
2	Electrical specifications	6
	2.1 Absolute maximum ratings	6
	2.2 Thermal data	6
	2.3 Application circuit	6
	2.4 Electrical characteristics	7
3	Functional description	10
4	Package information	11
5	Revision history	12

List of tables

Table 1.	Device summary	1
Table 2.	Absolute maximum ratings	6
Table 3.	Thermal data.	6
Table 4.	Electrical characteristics	7
Table 5.	Document revision history	12

List of figures

Figure 1.	Block diagram	5
Figure 2.	Pins connection diagram (top view)	5
Figure 3.	Application circuit	6
Figure 4.	Timing diagram	10
Figure 5.	Multiwatt15 mechanical data and package dimensions	11

1 Block and pins connection diagrams

Figure 1. Block diagram

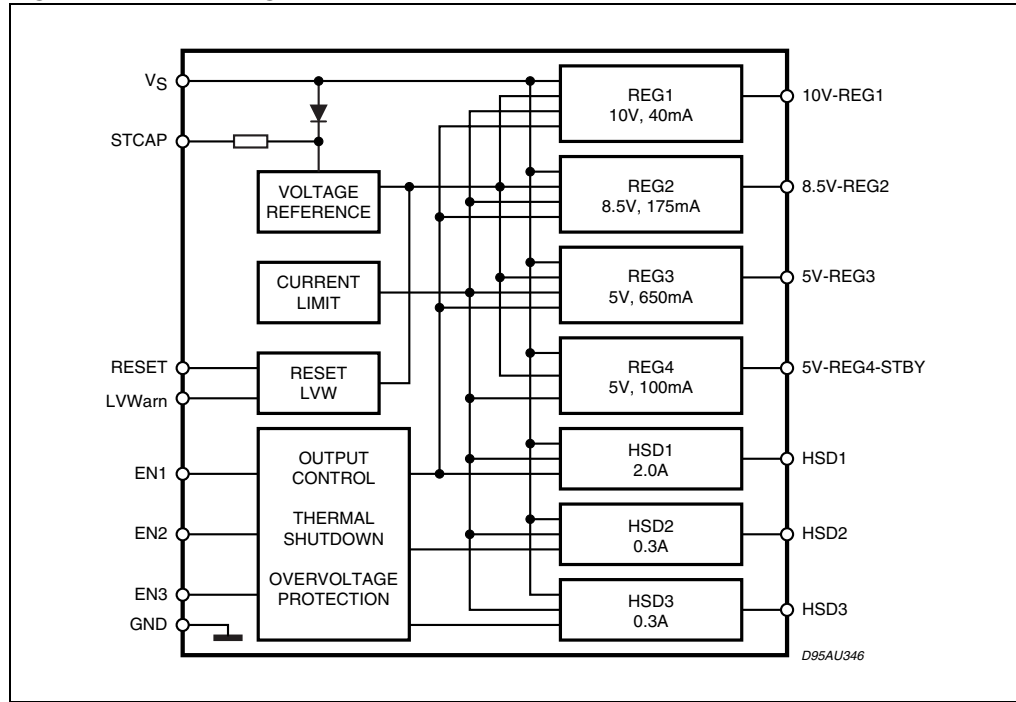
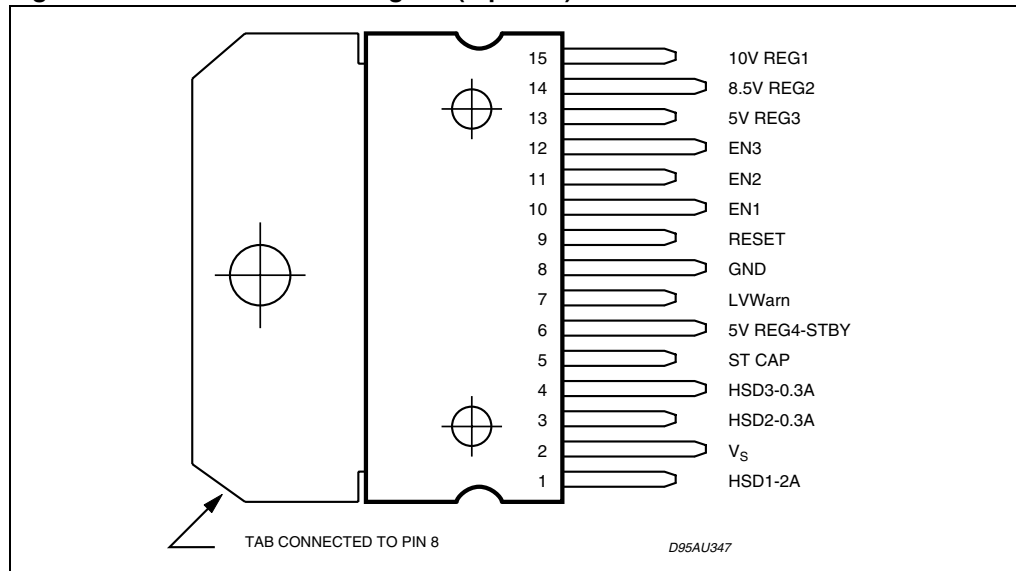

Figure 2. Pins connection diagram (top view)



2 Electrical specifications

2.1 Absolute maximum ratings

Table 2. Absolute maximum ratings

Symbol	Parameter	Value	Unit
V_S	DC operating supply voltage	-0.6 to 26.5	V
V_S	Transient supply overvoltages, rise time = 10 ms ,delay time = 115 ms	34	V
$V_{S,ovs}$	Overvoltage shutdown	27	V
V_{in}	Input voltages (EN1, EN2, EN3)	-0.6 to 6.0	V
V_{out}	Output voltages (LVWarn, RESET)	-0.6 to 6.0	V
T_{op}	Operating temperature range	-40 to 85	°C
T_{stg}	Storage temperature range	-40 to 150	°C

2.2 Thermal data

Table 3. Thermal data

Symbol	Parameter	Value	Unit
$R_{th\ j-case}$	Thermal resistance junction-to-case	2	°C/W

2.3 Application circuit

Figure 3. Application circuit

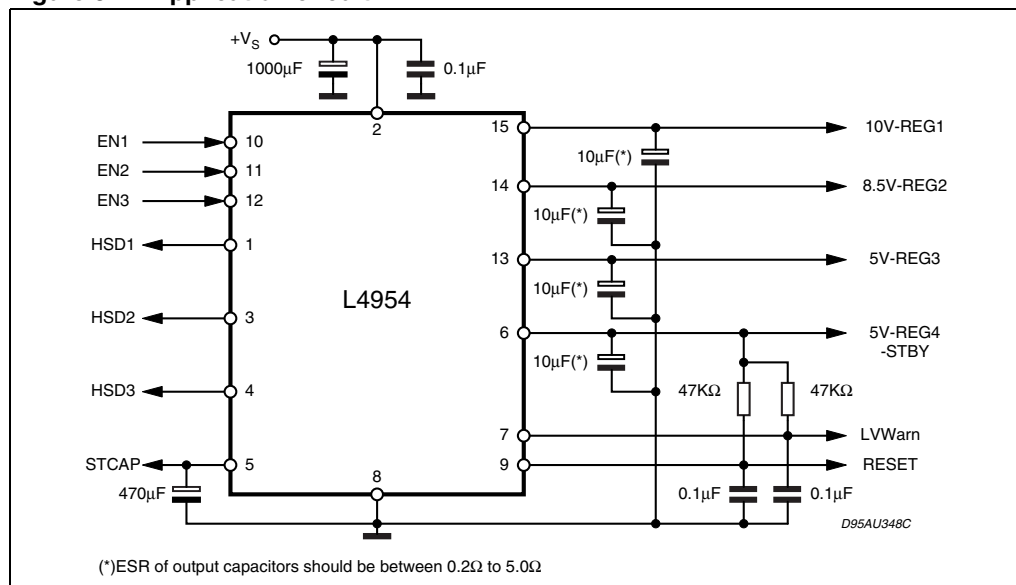

2.4 Electrical characteristics

Refer to the [Figure 3: Application circuit](#), $V_S = 14.4\text{ V}$; $T_{\text{amb}} = 25\text{ °C}$; $I_{\text{OUT}10} = 5\text{ mA}$; $I_{\text{OUT}8.5} = 5\text{ mA}$; $I_{\text{OUT}5} = 5\text{ mA}$; $I_{\text{OUT}5\text{ ST-BY}} = 0.5\text{ mA}$; $R_{\text{HSD}1} = 16\ \Omega$, $R_{\text{HSD}2,3} = 107\ \Omega$, unless otherwise specified.

Table 4. Electrical characteristics

Symbol	Parameter	Test condition	Min.	Typ.	Max.	Unit
V_S	Operating supply voltage	-	11	-	16	V
I_q	Maximum quiescent current	$I_{\text{OUT}10} = 40\text{ mA}$; $I_{\text{OUT}8.5} = 175\text{ mA}$; $I_{\text{OUT}5} = 650\text{ mA}$; $I_{\text{OUT}5\text{ ST-BY}} = 100\text{ mA}$; $R_{\text{HSD}1} = 8\ \Omega$; $R_{\text{HSD}2,3} = 53\ \Omega$	-	10	-	mA
$I_{q,\text{ST-BY}}$	Standby quiescent current	EN1, EN2, EN3 = 0 $I_{\text{OUT}5, \text{ST-BY}} = 50\text{ mA}$	-	420	-	mA
		EN1, EN2, EN3 = 0 $I_{\text{OUT}5, \text{ST-BY}} = 2\text{ mA}$	-	300	-	mA
V_{ENL}	EN1, EN2, EN3 input low voltage	-	0	-	0.8	V
V_{ENH}	EN1, EN2, EN3 input high voltage (outputs active)	-	2	-	5	V
10 V / 40 mA reg 1 output						
$V_{\text{OUT}10}$	Output voltage	$I_{\text{OUT}10} = 40\text{ mA}$	-	10	-	V
ΔV_{line}	Line regulation	$V_S = 11\text{ to }26\text{ V}$	-	2	-	mV
ΔV_{load}	Load regulation	$I_{\text{OUT}10} = 5\text{ to }40\text{ mA}$	-	2	-	mV
V_{DROPOUT}	Dropout voltage	$V_S = V_{\text{OUT}10} + 0.1\text{ V}$ $I_{\text{OUT}10} = 5\text{ mA}$	-	100	200	mV
		$V_S = V_{\text{OUT}10} + 0.5\text{ V}$ $I_{\text{OUT}10} = 40\text{ mA}$	-	500	600	mV
I_{q1}	Reg 1 quiescent current	$I_{\text{OUT}10} = 5\text{ mA}$	-	7	-	mA
		$I_{\text{OUT}10} = 40\text{ mA}$	-	7	-	mA
$I_{\text{lim}1}$	Current limit	-	-	100	-	mA
SVR1	Reg 1 supply voltage rejection	$f = 0.12\text{ to }10\text{ kHz}$; $I_{\text{OUT}10} = 25\text{ mA}$; $V_{\text{RIP}} = 1\text{ Vpp}$	-	55	-	dB
8.5V / 175 mA reg 2 output						
$V_{\text{OUT}8.5}$	Output voltage	$I_{\text{OUT}8.5} = 175\text{ mA}$	-	8.5	-	V
ΔV_{line}	Line regulation	$V_S = 11\text{ to }26\text{ V}$	-	2	-	mV
ΔV_{load}	Load regulation	$I_{\text{OUT}8.5} = 5\text{ to }175\text{ mA}$	-	10	-	mV
V_{DROPOUT}	Dropout voltage	$V_S = V_{\text{OUT}8.5} + 0.3\text{ V}$ $I_{\text{OUT}8.5} = 5\text{ mA}$	-	300	400	mV
		$V_S = V_{\text{OUT}8.5} + 1\text{ V}$ $I_{\text{OUT}8.5} = 175\text{ mA}$	-	-	1.1	V

Table 4. Electrical characteristics (continued)

Symbol	Parameter	Test condition	Min.	Typ.	Max.	Unit
I_{q2}	Reg 2 quiescent current	$I_{OUT8.5} = 5 \text{ mA}$	-	7	-	mA
		$I_{OUT8.5} = 175 \text{ mA}$	-	7	-	mA
I_{lim2}	Current limit		-	300	-	mA
5 V / 650 mA reg 3 output						
V_{OUT5}	Output voltage	$I_{OUT5} = 650 \text{ mA}$	-	5	-	V
ΔV_{line}	Line regulation	$V_S = 7 \text{ to } 26 \text{ V}$	-	2	-	mV
ΔV_{load}	Load regulation	$I_{OUT5} = 5 \text{ to } 650 \text{ mA}$	-	9	-	mV
$V_{DROPOUT}$	Dropout voltage	$V_S = V_{OUT5} + 0.3 \text{ V}$ $I_{OUT5} = 5 \text{ mA}$	-	300	400	mV
		$V_S = V_{OUT5} + 1 \text{ V}$ $I_{OUT5} = 650 \text{ mA}$	-	1	1.1	V
I_{q3}	Reg 3 quiescent current	$I_{OUT5} = 5 \text{ mA}$	-	7	-	mA
		$I_{OUT5} = 650 \text{ mA}$	-	7	-	mA
I_{lim3}	Current limit	-	-	1.25	-	A
SVR3	Reg 3 supply voltage rejection	$f = 0.12 \text{ to } 10 \text{ kHz}$; $I_{OUT5} = 325 \text{ mA}$; $V_{RIP} = 1 \text{ Vpp}$	-	55	-	dB
5V / 100 mA standby reg 4 output						
$V_{OUT5STBY}$	Output voltage	$I_{OUT5STBY} = 100 \text{ mA}$	-	5	-	V
ΔV_{line}	Line regulation	$V_S = 7 \text{ to } 26 \text{ V}$	-	0.8	-	mV
ΔV_{load}	Load regulation	$I_{out} = 0.5 \text{ to } 100 \text{ mA}$	-	3.5	-	mV
$V_{DROPOUT}$	Dropout voltage	$V_S = V_{REG5STBY} + 0.1 \text{ V}$ $I_{out5STBY} = 5 \text{ mA}$	-	100	200	mV
		$V_S = V_{REG5STBY} + 0.5 \text{ V}$ $I_{out5STBY} = 100 \text{ mA}$	-	500	600	mV
I_{q4}	Reg 4 quiescent current	$I_{OUT5STBY} = 2 \text{ mA}$	-	0.25	-	mA
		$I_{OUT5STBY} = 100 \text{ mA}$	-	0.35	-	mA
I_{lim4}	Current limit	-	-	190	-	mA
SVR4	Reg 4 supply voltage rejection	$f = 0.12 \text{ to } 10 \text{ kHz}$ $I_{out5STBY} = 50 \text{ mA}$; $V_{RIP} = 1 \text{ Vpp}$	-	55	-	dB
2 A HSD1						
$V_{sat,peak}$	Maximum output current saturation voltage	$R_{HSD1} = 8 \Omega$	-	600	-	mV
I_q	Quiescent current	-	-	9	-	mA
I_{lim}	Current limit	$R_{HSD1} = 0.5 \Omega$	-	3.5	-	A
I_{leak1}	Output leakage current	All driver outputs are off	-	20	-	mA

Table 4. Electrical characteristics (continued)

Symbol	Parameter	Test condition	Min.	Typ.	Max.	Unit
0.3 A HSD2 & HSD3						
V_{sat}	Maximum output current saturation voltage	$R_{HSD2,3} = 53 \Omega$	-	150	-	mV
I_q	Quiescent current	-	-	1.5	-	mA
I_{lim}	Current limit	$R_{HSD2,3} = 0.5 \Omega$	-	500	-	mA
$I_{leak2,3}$	Output leakage current	All driver outputs are off	-	10	-	μ A
SVR2	Reg 1 supply voltage rejection	$f = 0.12$ to 10 kHz; $I_{OUT8.5} = 100$ mA; $V_{RIP} = 1$ Vpp	-	55	-	dB
LVWARN OUTPUT						
TH_{LVW}	LVW threshold on STCAP	-	-	7.5	-	V
V_{LVW}	LVW output voltage	STCAP < 7.5 V; $V_{IL} = "0"$	0	-	0.4	V
		STCAP > 7.5 V $V_{IH} = "1"$	2.75	-	5	V
t_{rise}	LVW output rise time	$C_{LVW} = 0.1 \mu$ F	-	3.9	-	ms
t_{fall}	LVW output fall time		-	12.6	-	μ s
Reset output						
T_{HRES}	Reset threshold on reg 4	-	-	4.5	-	V
V_{RES}	Reset output voltage	Set V_S so that $V_{OUT5STBY} < 4.5$ V; $V_{IL} = "0"$	0	-	0.4	V
		Set V_S so that $V_{OUT5STBY}$ is not less than normal reg 4 output voltage; $V_{IH} = "1"$	2.75	-	5	V
t_{rise}	Reset output rise time	$C_{RESET} = 0.1 \mu$ F	-	4.5	-	ms
t_{fall}	Reset output fall time		-	37	-	μ s

3 Functional description

The L4954 includes a monitoring circuit to warn the microprocessor if a low voltage or no voltage condition is occurring.

When the voltage on the STCAP pin drops below 7.5 V (typ), the LVW output goes low. This tells the microprocessor to stop executing code and save vital information. The reset output goes low when REG4 (5 V - standby) drops below ($V_{REG4} - 250\text{ mV}$) or 4.75 V is minimum value. The RESET output doesn't go above 0.4V until REG4 has gone back above 4.75 V (min).

Any spike tells the microprocessor to start operating. Once the STCAP line passes 7.5 V (typ), the LVWarn output also returns to high state.

The STCAP pin acts like a delay circuit. Due to the large capacitor (470 μF), the STCAP pin allows the battery voltage to decay slowly giving the microprocessor time to store data.

Also, during short low voltage or negative voltage conditions, the STCAP pin protects the 5 V standby output from dropping below the RESET and LVW trip points. The four outputs are expected to follow the battery voltage down to 11 V for REG1, 9 V for REG2, 6 V for REG3 and REG4.

The L4954 has a standby mode to keep the microprocessor and memories alive during ignition off conditions. The EN1 input pin is controlled by the microprocessor. A high on the EN1 input turns on REG1, REG2, REG3, and HSD1. A Low on EN1 places the part in stand-by mode with REG4 on. The high side driver outputs HSD2 and HSD3 are controlled by EN2 and EN3 respectively: a low on the control input turns the corresponding high side driver off.

Figure 4. Timing diagram

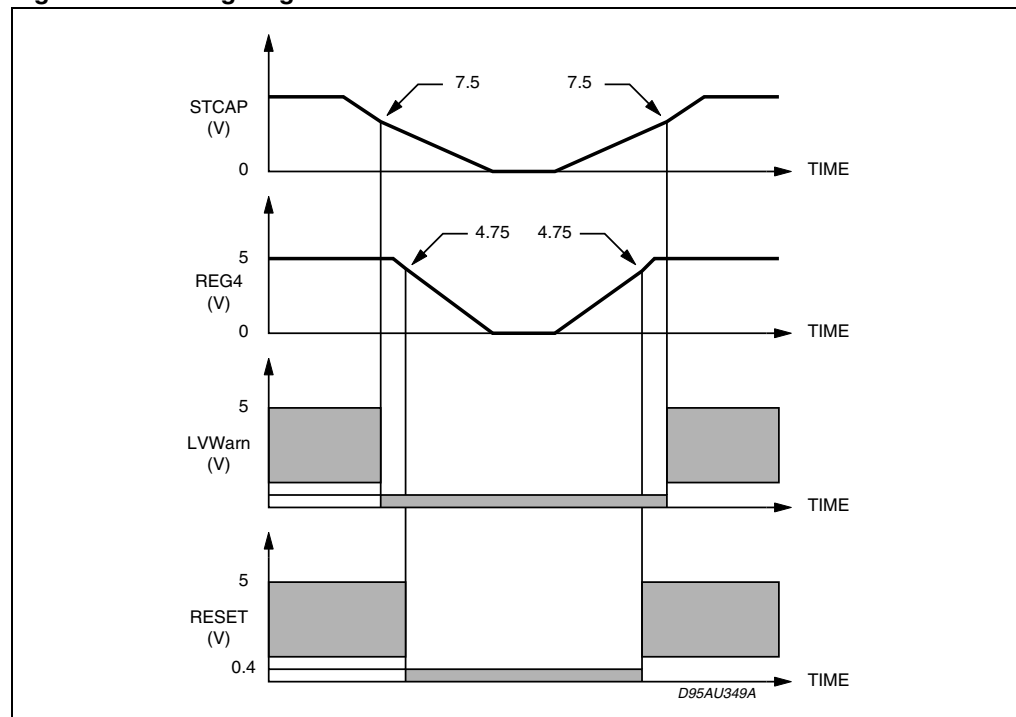

4 Package information

In order to meet environmental requirements, ST offers these devices in different grades of ECOPACK® packages, depending on their level of environmental compliance. ECOPACK® specifications, grade definitions and product status are available at: www.st.com.

ECOPACK® is an ST trademark.

Figure 5. Multiwatt15 mechanical data and package dimensions

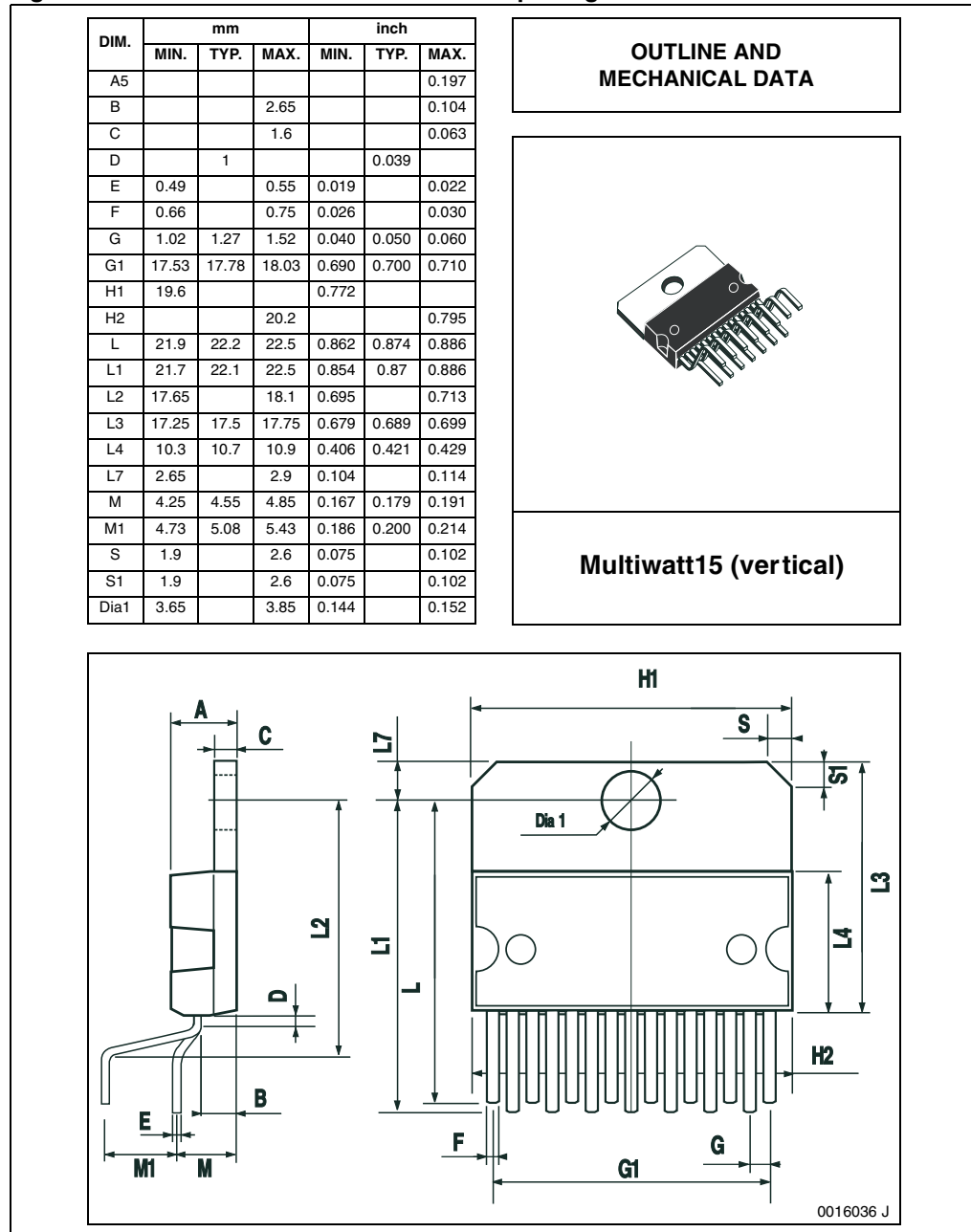

5 Revision history

Table 5. Document revision history

Date	Revision	Changes
12-Jul-2010	1	Initial release.

Please Read Carefully:

Information in this document is provided solely in connection with ST products. STMicroelectronics NV and its subsidiaries ("ST") reserve the right to make changes, corrections, modifications or improvements, to this document, and the products and services described herein at any time, without notice.

All ST products are sold pursuant to ST's terms and conditions of sale.

Purchasers are solely responsible for the choice, selection and use of the ST products and services described herein, and ST assumes no liability whatsoever relating to the choice, selection or use of the ST products and services described herein.

No license, express or implied, by estoppel or otherwise, to any intellectual property rights is granted under this document. If any part of this document refers to any third party products or services it shall not be deemed a license grant by ST for the use of such third party products or services, or any intellectual property contained therein or considered as a warranty covering the use in any manner whatsoever of such third party products or services or any intellectual property contained therein.

UNLESS OTHERWISE SET FORTH IN ST'S TERMS AND CONDITIONS OF SALE ST DISCLAIMS ANY EXPRESS OR IMPLIED WARRANTY WITH RESPECT TO THE USE AND/OR SALE OF ST PRODUCTS INCLUDING WITHOUT LIMITATION IMPLIED WARRANTIES OF MERCHANTABILITY, FITNESS FOR A PARTICULAR PURPOSE (AND THEIR EQUIVALENTS UNDER THE LAWS OF ANY JURISDICTION), OR INFRINGEMENT OF ANY PATENT, COPYRIGHT OR OTHER INTELLECTUAL PROPERTY RIGHT.

UNLESS EXPRESSLY APPROVED IN WRITING BY AN AUTHORIZED ST REPRESENTATIVE, ST PRODUCTS ARE NOT RECOMMENDED, AUTHORIZED OR WARRANTED FOR USE IN MILITARY, AIR CRAFT, SPACE, LIFE SAVING, OR LIFE SUSTAINING APPLICATIONS, NOR IN PRODUCTS OR SYSTEMS WHERE FAILURE OR MALFUNCTION MAY RESULT IN PERSONAL INJURY, DEATH, OR SEVERE PROPERTY OR ENVIRONMENTAL DAMAGE. ST PRODUCTS WHICH ARE NOT SPECIFIED AS "AUTOMOTIVE GRADE" MAY ONLY BE USED IN AUTOMOTIVE APPLICATIONS AT USER'S OWN RISK.

Resale of ST products with provisions different from the statements and/or technical features set forth in this document shall immediately void any warranty granted by ST for the ST product or service described herein and shall not create or extend in any manner whatsoever, any liability of ST.

ST and the ST logo are trademarks or registered trademarks of ST in various countries.

Information in this document supersedes and replaces all information previously supplied.

The ST logo is a registered trademark of STMicroelectronics. All other names are the property of their respective owners.

© 2010 STMicroelectronics - All rights reserved

STMicroelectronics group of companies

Australia - Belgium - Brazil - Canada - China - Czech Republic - Finland - France - Germany - Hong Kong - India - Israel - Italy - Japan - Malaysia - Malta - Morocco - Philippines - Singapore - Spain - Sweden - Switzerland - United Kingdom - United States of America

www.st.com

