

PLEASE CHECK WWW.MOLEX.COM FOR LATEST PART INFORMATION

Part Number: [0191640015](#)
Status: **Active**
Description: Perma-Seal™ Male Quick Disconnect Tab for 18-22 AWG Wire, Tab Size 6.35mm (.250") x .81mm (.032")

Documents:

[Drawing \(PDF\)](#) [RoHS Certificate of Compliance \(PDF\)](#)

Agency Certification

CSA LR18689
 UL E79133

General

Product Family Quick Disconnects
 Series [19164](#)
 Crimp Quality Equipment Yes
 Product Name Perma-Seal™
 Type Quick Disconnect

Physical

Barrel Type Closed
 Color - Resin Natural
 Flammability 94V-0
 Gender Male
 Glow-Wire Compliant No
 Insulation NiAc™
 Lock to Mating Part None
 Material - Metal Brass
 Material - Plating Mating Zinc Chromate
 Material - Plating Termination Zinc Chromate
 Material - Resin Nylon
 Orientation Straight
 Packaging Type Bag
 Plating min: Mating (µin) 200
 Plating min: Mating (µm) 5
 Plating min: Termination (µin) 200
 Plating min: Termination (µm) 5
 Tab Thickness 0.81mm (.032")
 Tab Width 6.35mm (.250")
 Temperature Range - Operating -55°C to +125°C
 Wire Insulation Diameter 3.81mm (.150") max.
 Wire Size AWG 18, 20, 22
 Wire Size mm² 0.25 - 1.50

Electrical

Voltage - Maximum 600V

Material Info

Old Part Number SAA-9260

Reference - Drawing Numbers

Sales Drawing SD-19164-039

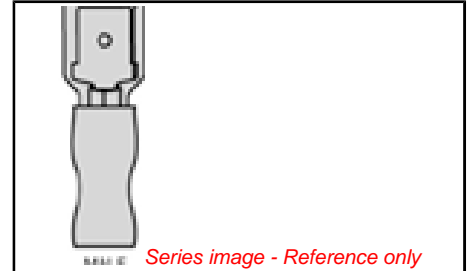

EU RoHS

ELV and RoHS Compliant
REACH SVHC
 Not Reviewed
Halogen-Free Status
 Not Reviewed

China RoHS



Need more information on product environmental compliance?

Email productcompliance@molex.com
 For a multiple part number RoHS Certificate of Compliance, [click here](#)

Please visit the [Contact Us](#) section for any non-product compliance questions.

Search Parts in this Series

[19164Series](#)

Application Tooling | FAQ

Tooling specifications and manuals are found by selecting the products below. Crimp Height Specifications are then contained in the Application Tooling Specification document.

Global

Description	Product #
Hand Crimp Tool	0640014500
Hand Crimp Tool	0640014700
Crimp Head for the AT-200™ Pneumatic Hand Tool	0640054500
Crimp Head for the AT-200™ Pneumatic Hand Tool	0640054700

PLEASE CHECK WWW.MOLEX.COM FOR LATEST PART INFORMATION

MATERIAL NUMBER	ENG. NUMBER	TAPE MATERIAL NUMBER	TAPE ENG NUMBER	WIRE SIZE AWG	WIRE SIZE MM SQ.	NYLON COLOR	B MAX.	D MWID (E1)	E MIN. DIA.	F MAX. DIA.	H (E1) NOMINAL
191640015	SAA-9260	191640016	SAA-9260T	22-18	.25-1.5	RED	.45/11.4	.17/4.3	.049/1.25	.29/7.4	.47/12.0
191640048	SBB-9262	191640049	SBB-9262T	16-14	1.0-2.5	BLUE	.45/11.4	.18/4.5	.082/2.08	.31/7.9	.47/12.0
191640075	SC-9280	N/A	N/A	12-10	4.0-6.0	YELLOW	.46/11.7	.23/5.8	.148/3.76	.39/9.9	N/A

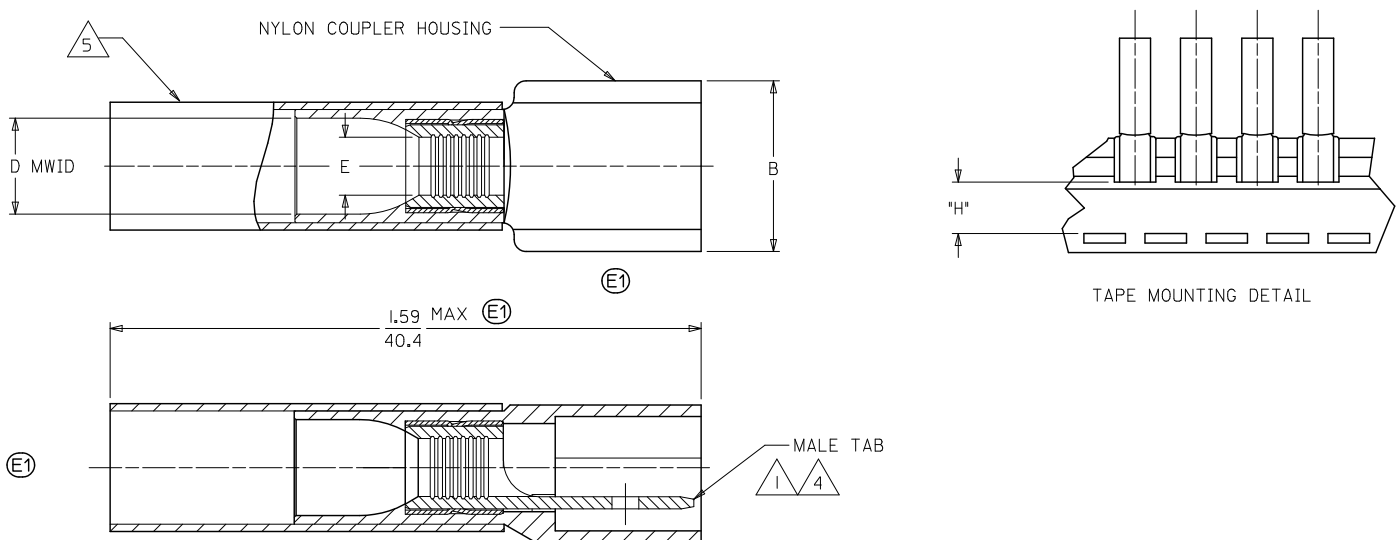

TAPE MOUNTING DETAIL

- NOTES:
- (E1) 1. MALE TAB CONFORMS TO UL310.
 - 2. ALL DIMENSIONS SHOWN ARE BEFORE SHRINK TUBING IS HEATED.
 - 3. "MWID" DENOTES MAX. WIRE INSULATION DIA.
 - (E1) 4. TAB MATERIAL: COPPER ALLOY, PLATING: TIN
 - (E1) 5. NYLON HEAT SHRINKABLE TUBING WITH HOTMELT INNER LINER. SEE CHART FOR COLOR.
 - (E1) 6. ALL PARTS ARE ROHS COMPLIANT.

SALES DRAWING

CORRECT SPECS EC NO: WNAZ010-0115 DRAWN: THRODAHL 2010/02/16 CHKD: JMACNEIL 2010/02/18 APPR: JMACNEIL 2010/02/22 DESCRIPTION	QUALITY SYMBOLS	GENERAL TOLERANCES (UNLESS SPECIFIED)	DIMENSION STYLE IN/MM	SCALE ---	DESIGN UNITS INCH	THIRD ANGLE PROJECTION
	▽=0 ▽=0	4 PLACES ± --- ± --- 3 PLACES ± --- ± --- 2 PLACES ± --- ± --- 1 PLACE ± --- ± --- ANGULAR ± ---°	DRAWN BY BRE DATE 2002/10/25 CHECKED BY HEB DATE 2002/10/25 APPROVED BY RWD DATE 2002/10/25	TITLE PERMA-SEAL COUPLER MALE TAB TERMINAL		
	DRAFT WHERE APPLICABLE MUST REMAIN WITHIN DIMENSIONS	MATERIAL NO. SEE CHART SIZE B	MOLEX INCORPORATED DOCUMENT NO. SD-19164-039	SHEET NO. 1 OF 1		
	THIS DRAWING CONTAINS INFORMATION THAT IS PROPRIETARY TO MOLEX INCORPORATED AND SHOULD NOT BE USED WITHOUT WRITTEN PERMISSION					