

**PLEASE CHECK WWW.MOLEX.COM FOR LATEST PART INFORMATION**

**Part Number:** [0191640014](#)  
**Status:** **Active**  
**Description:** Perma-Seal™ Butt Splice for 18-22 AWG Wire, Mylar Tape Carrier

**Documents:**

[Drawing \(PDF\)](#) [RoHS Certificate of Compliance \(PDF\)](#)

**Agency Certification**

CSA LR18689  
 UL E32244

**General**

Product Family Splices  
 Series [19164](#)  
 Crimp Quality Equipment Yes  
 Mil-Spec N/A  
 Product Name Butt - Funnel Entry, Perma-Seal™

**Physical**

Barrel Type Closed  
 Flammability 94V-2  
 Insulation NiAc™  
 Packaging Type Adhesive Tape on Reel  
 Temperature Range - Operating -55°C to +125°C  
 Wire Insulation Diameter 5.3mm (.21") max  
 Wire Size AWG 18, 20, 22  
 Wire Size mm² 0.38 - 0.96

**Electrical**

Voltage - Maximum 600V

**Material Info**

Old Part Number SAA-22-18T

**Reference - Drawing Numbers**

Sales Drawing SD-19164-017

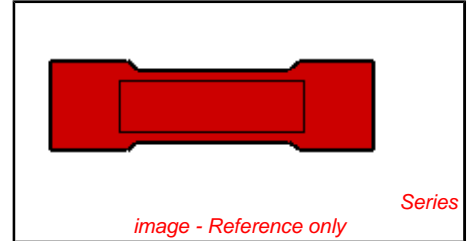

**EU RoHS**

**ELV and RoHS Compliant**  
**REACH SVHC**  
 Not Reviewed  
**Halogen-Free Status**  
**Not Reviewed**

**China RoHS**



**Need more information on product environmental compliance?**

Email [productcompliance@molex.com](mailto:productcompliance@molex.com)  
 For a multiple part number RoHS Certificate of Compliance, [click here](#)

Please visit the [Contact Us](#) section for any non-product compliance questions.

**Search Parts in this Series**

[19164Series](#)

**Application Tooling | [FAQ](#)**

*Tooling specifications and manuals are found by selecting the products below. Crimp Height Specifications are then contained in the Application Tooling Specification document.*

**Global**

Description	Product #
Crimp Dies for MTA-100 Tape Applicator used in 3BF Press, MTA-105 Tape Applicator used in TM-2000™ Press, and ATP-301 Air Crimping Press for Mylar Tape Mounted Terminals	<a href="#">0192880264</a>
Hand Crimp Tool, UL 0640017400 Approved	
Power Crimp Tool Head for Prema-	<a href="#">0640057400</a>

This document was generated on 03/16/2010

**PLEASE CHECK [WWW.MOLEX.COM](http://WWW.MOLEX.COM) FOR LATEST PART INFORMATION**

MATERIAL NUMBER	ENGINEERING NUMBER	MYLAR TAPE MATERIAL NUMBER	MYLAR TAPE ENGINEERING NUMBER	PERMA-SEAL COLOR	WIRE AWG 3	"A" (F) MIN	"B" Ø MAX	(F) "C" MAX	"H" ±.010/0.25	"D" MIN
I91640013	SAA-22-18	I91640014	SAA-22-18T	RED	22-18	.185/4.70	.280/7.11	1.55/39.4	.767/19.48	.059/1.50
I91640044	SBB-16-14	I91640045	SBB-16-14T	BLUE	16-14	.195/4.95	.308/7.82	1.55/39.4	.727/18.47	.091/2.31
I91640056	SC-12-10	I91640057	SC-12-10T	YELLOW	12-10	.275/6.99	.383/9.73 (F)	1.80/45.7	.800/23.32	.139/3.53 (F)
I91640079	(F) SD-354	---	---	RED	8	.300/7.62	.448/11.38	2.05/52.4	---	.165/4.19

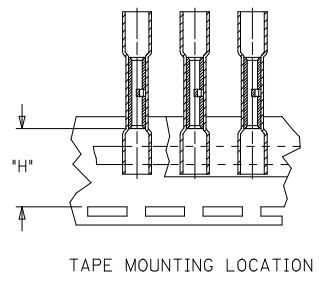
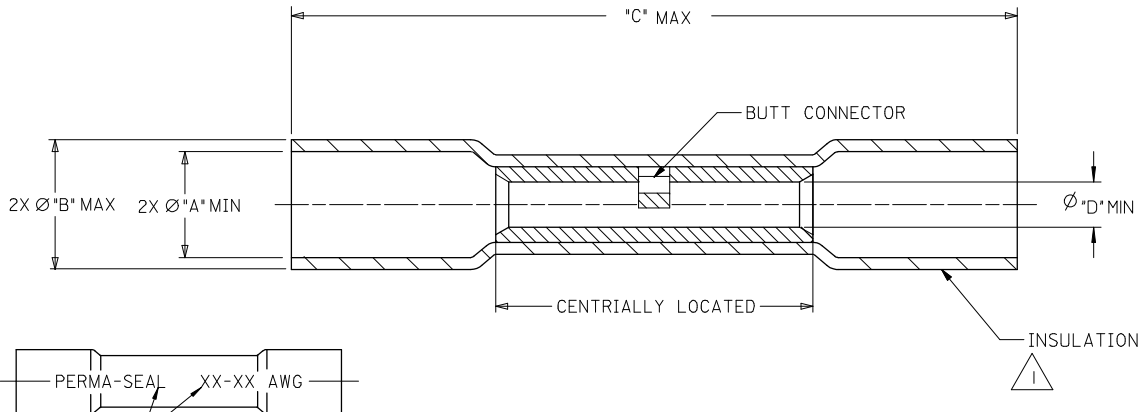

SALES DRAWING

- NOTES,
- 1. INSULATION MATERIAL; HEAT SHRINKABLE TUBING WITH HOTMELT INNER LINER. SEE CHART FOR COLOR.
  - 2. SEAMLESS TIN PLATED COPPER TERMINAL.
  - 3. PRINTED TEXT IN BLACK APPROXIMATELY .12 (3.0) HIGH.
  - (F) 4. PART IS ROHS COMPLIANT.

UPDATE MAX LENGTH IEC NO: WNA2008-0006 2007/12/20 TIDRWANETHRODAHL CHKD: JMACNEIL 2007/12/29 APPR: JMACNEIL 2008/01/08 REV DESCRIPTION	QUALITY SYMBOLS	GENERAL TOLERANCES (UNLESS SPECIFIED)	DIMENSION STYLE IN/MM	SCALE 1:1	DESIGN UNITS INCH	THIRD ANGLE PROJECTION
	▽=0	4 PLACES ± --- ± ---	DRAWN BY BRE	DATE 2002/03/22	TITLE PERMA-SEAL NIAC BUTT CONNECTORS	
	▽=0	3 PLACES ± --- ± ---	CHECKED BY HEB	DATE 2002/03/22	MOLEX INCORPORATED	
		2 PLACES ± --- ± ---	APPROVED BY RWD	DATE 2002/03/22	MATERIAL NO.	DOCUMENT NO. SD-19164-017
	1 PLACE ± --- ± ---	ANGULAR ± ---°	SEE CHART		THIS DRAWING CONTAINS INFORMATION THAT IS PROPRIETARY TO MOLEX INCORPORATED AND SHOULD NOT BE USED WITHOUT WRITTEN PERMISSION	
		DRAFT WHERE APPLICABLE MUST REMAIN WITHIN DIMENSIONS				