

MC9S12XD Family

16-bit Microprocessor Family (covers MC9S12XD64 through MC9S12XDP512 and MC3S12XDT256/MC3S12XDG128)

Introduction

Targeted at automotive multiplexing applications, the MC9S12XD Family will deliver 32-bit performance with all the advantages and efficiencies of a 16-bit MCU. The S12X is designed to retain the low cost, low power consumption, excellent EMC performance and code-size efficiency advantages enjoyed by users of Freescale's previous 16-bit MC9S12 MCU family.

Based around an enhanced S12 core, the MC9S12XD Family will deliver two to five times the performance of a 25 MHz S12 whilst retaining a high degree of pin and code compatibility with the original S12D - family.

The MC9S12XD Family features the performance boosting XGATE co-processor. The XGATE, which is programmable in "C" language, has an instruction set which is optimized for data movement, logic and bit manipulation instructions. It runs at twice the bus frequency of the S12X and off-loads the CPU by providing high speed data transfer (and data processing) between any peripheral module, RAM and I/O ports. This is particularly useful in applications such as automotive gateways where there are multiple busses carrying heavy data traffic which would otherwise exert a heavy interrupt/processing load on the CPU.

Features

The MC9S12XD Family will feature an enhanced MSCAN module which, when used in conjunction with XGATE, delivers FullCAN performance with virtually unlimited number of mailboxes and retains backwards compatibility with the MSCAN module featured on previous S12 products.

Memory options will range from 64 Kbytes to 512 Kbytes of Freescale's industry-leading, full automotive spec SG-Flash with additional integrated EEPROM.

In addition to the rich S12 peripheral set, the MC9S12XD Family will feature more RAM, extra A/D channels, new timer features and additional LIN-compatible SCI ports compared with the original S12 D-Family. The MC9S12XD Family also features a new flexible interrupt handler which allows multilevel nested interrupts.

The MC9S12XD Family has full 16-bit data paths throughout. The non-multiplexed expanded bus interface available on the 144-pin versions allows an easy interface to external memories. The inclusion of a PLL circuit allows power consumption and performance to be adjusted to suit operational requirements. System power consumption is further improved with the new "fast exit from STOP mode" feature and an ultra low power wakeup timer.

In addition to the I/O ports available in each module, up to 25 further I/O ports are available with interrupt capability allowing wakeup from STOP or WAIT mode.

The MC9S12XD Family will be available in 144-pin LQFP (with optional external bus), 112-pin, and 80-pin options.

Features

Features of the MC9S12XD Family are listed here. Please see [Table 1](#) for memory options and [Table 2](#) for the peripheral features that are available on the different family members.

16-bit CPU12X	<ul style="list-style-type: none">• Upward compatible with MC9S12 instruction set• Enhanced indexed addressing• Additional (superset) instructions to improve 32-bit calculations and semaphore handling• Access large data segments independent of PPAGE
Enhanced Interrupt Module	<ul style="list-style-type: none">• Eight levels of nested interrupt• Flexible assignment of interrupt sources to each interrupt level.• One non-maskable high priority interrupt (XIRQ)• Wakeup interrupt inputs<ul style="list-style-type: none">– IRQ and non-maskable XIRQ

XGATE

- Programmable, high performance I/O co-processor module — up to 80 MIPS RISC performance
- Transfers data to or from all peripherals and RAM without CPU intervention or CPU wait states
- Performs logical, shifts, arithmetic, and bit operations on data
- Enables FullCAN capability when used in conjunction with MSCAN module
- Full LIN master or slave capability when used in conjunction with the six integrated LIN SCI modules
- Can interrupt the HCS12X CPU signalling transfer completion
- Triggers from any hardware module as well as from the CPU possible

Memory Options

- 64K, 128K, 256K, 384K and 512K byte Flash
- 128K and 256K ROM
- Flash General Features
 - Erase sector size 1024 bytes
 - Automated program and erase algorithm
 - Fast sector erase and word program operation
 - 2-stage command pipeline for faster multi-word program times
 - Sector erase abort feature for critical interrupt response
 - Protection scheme to prevent accidental program or erase
 - Security option to prevent unauthorized access
 - Code integrity check using built-in data compression
 - Sense-amp margin level setting for reads
- 1K, 2K, 4K byte EEPROM
 - Small erase sector (4 bytes)
 - Automated program and erase algorithm
 - Fast sector erase and word program operation
 - 2-stage command pipeline for faster multi-word program times
 - Sector erase abort feature for critical interrupt response
 - Protection scheme to prevent accidental program or erase
- 4K, 8K, 12K, 14K, 16K, 20K, 32K Byte RAM

Features

Oscillator (OSC_LCP)

- Loop control Pierce oscillator using a 0.5 MHz to 16 MHz crystal
- Option for full-swing Pierce without internal feedback resistor using a 0.5 MHz to 40 MHz crystal
- Current gain control on amplitude output
 - Signal with low harmonic distortion
 - Low power
 - Good noise immunity
 - Eliminates need for external current limiting resistor
- Transconductance sized for optimum start-up margin for typical crystals
- Clock monitor

Clock and Reset Generator (CRG)

- Phase-locked-loop clock frequency multiplier
 - Reference divider
 - Automatic bandwidth control mode for low-jitter operation
 - Automatic frequency lock detector
- Fast wakeup from STOP in self clock mode for power saving and immediate program execution
- Computer operating properly (COP) watchdog with optional safety window to initialize timeout counter
- Real time interrupt for task scheduling purposes or cyclic wakeup from low power modes
- System reset generation

Non-Multiplexed External Bus (144 Pin package only)

- 16 bit data
 - Support for external WAIT input or internal wait cycles to adapt MCU speed to peripheral speed requirements
 - Up to four chip select outputs to select 16K, 1M, 2M and 4M byte address spaces
 - Supports glue-less interface to popular asynchronous RAMs and Flash devices
 - External address space 4M byte for data and program space
-

Analog-to-Digital Converter (ATD)	<ul style="list-style-type: none"> • Up to two independent ADC converters (see Table 2) • 8-bit or 10-bit resolution • Multiplexer for 16 analog input channels • 7 μs, 10-bit single conversion time • Programmable sample time • Left/right, signed/unsigned result data • Continuous conversion mode • Multiple channel scans • External and internal conversion trigger capability • Pins can also be used as digital I/O
Enhanced Capture Timer (ECT)	<ul style="list-style-type: none"> • Eight 16-bit channels for input capture or output compare • One 16-bit free-running counter with 8-bit precision prescaler • One 16-bit modulus down counter with 8-bit precision prescaler • Four 8-bit or two 16-bit pulse accumulators • Four channels have enhanced input capture capabilities: <ul style="list-style-type: none"> – Delay counter for noise immunity – 16-bit capture buffer – 8-bit pulse accumulator buffer
Periodic Interrupt Timer (PIT)	<ul style="list-style-type: none"> • Four channel x 24-bit modulus down-count timers <ul style="list-style-type: none"> – Timeout interrupt – Timeout peripheral trigger • Start of timers can be aligned
Pulse Width Modulator (PWM)	<ul style="list-style-type: none"> • Eight channel x 8-bit or four channel x 16-bit pulse width modulator • Programmable period and duty cycle per channel • Center-aligned or left-aligned outputs • Programmable clock select logic with a wide range of frequencies

Features

Multi-scalable Controller Area Networks (MSCAN)

- Up to five MSCAN modules (see [Table 2](#))
- CAN 2.0 A, B software compatible
 - Standard and extended data frames
 - 0–8 bytes data length
 - Programmable bit rate up to 1 Mbps
- Five receive buffers with FIFO storage scheme
- Three transmit buffers with internal prioritization
- Flexible identifier acceptance filter programmable as:
 - 2 x 32-bit
 - 4 x 16-bit
 - 8 x 8-bit
- Wakeup with integrated low-pass filter option
- Loop back for self test
- Listen-only mode to monitor CAN bus
- Bus-off recovery by software intervention or automatically
- 16-bit time stamp of transmitted/received messages
- FullCAN capability when used in conjunction with XGATE

Serial Peripheral Interface (SPI)

- Up to three SPI modules (see [Table 2](#))
- Full-duplex or single-wire bidirectional
- Double-buffered transmit and receive
- Master or slave mode
- MSB-first or LSB-first shifting
- Serial clock phase and polarity options

Serial Communication Interfaces (SCI)

- Up to six SCI modules (see [Table 2](#))
 - Full-duplex or single wire operation
 - Standard mark/space non-return-to-zero (NRZ) format
 - Selectable IrDA 1.4 return-to-zero-inverted (RZI) format with programmable pulse widths
 - 13-bit baud rate selection
 - Programmable character length
 - Programmable polarity for transmitter and receiver
 - Receive wakeup on active edge
 - Break detect and transmit collision detect supporting LIN
-

Inter IC Module (IIC)	<ul style="list-style-type: none"> • Up to two IIC modules (see Table 2) • Compatible with I2C Bus standard • Multi-master operation • Software programmable for one of 256 different serial clock frequencies • Software selectable acknowledge bit • Interrupt driven byte-by-byte data transfer • Arbitration lost interrupt with automatic mode switching from master to slave • Calling address identification interrupt • Start and stop signal generation/detection • Repeated start signal generation • Acknowledge bit generation/detection • Bus busy detection • supports 400 Kbps
Background Debug (BDM)	<ul style="list-style-type: none"> • Background debug controller (BDM) with single-wire interface <ul style="list-style-type: none"> – Non-intrusive memory access commands – Supports in-circuit programming of on-chip non-volatile memory – Supports security
Debugger (XDBG)	<ul style="list-style-type: none"> • Four comparators A, B, C and D <ul style="list-style-type: none"> – Each can monitor CPU or XGATE busses – A and C compares 23-bit address bus and 16-bit data bus with mask register – B and D compares 23-bit address bus only – Three modes: simple address/data match, inside address range or outside address range • 64 x 64-bit circular trace buffer to capture change-of-flow addresses or address and data of every access • Tag-type or force-type hardware breakpoint requests
System Protection	<ul style="list-style-type: none"> • Power-on reset (POR) • illegal address detection with reset • Low-voltage detection with interrupt or reset
Input/Output	<ul style="list-style-type: none"> • up to 117 general-purpose input/output (I/O) pins depending on the package option and 2 input-only pins • Hysteresis and configurable pullup/pulldown device on all input pins • Configurable drive strength on all output pins

Features

Package Options	<ul style="list-style-type: none">• 144-pin low-profile quad flat-pack (LQFP)• 112-pin low-profile quad flat-pack (LQFP)• 80-pin quad flat-pack (QFP)
Operating Conditions	<ul style="list-style-type: none">• Ambient temperature range -40°C to 125°C• Temperature options:<ul style="list-style-type: none">– -40°C to 85°C– -40°C to 105°C– -40°C to 125°C• Supply voltage 3.15V to 5.5V• Internal voltage regulator providing 2.5 V logic supply<ul style="list-style-type: none">– 40 MHz maximum CPU bus frequency in single chip mode– 80 MHz maximum XGATE bus frequency

MC9S12XD Family Block Diagram

MC9S12XD Family Block Diagram

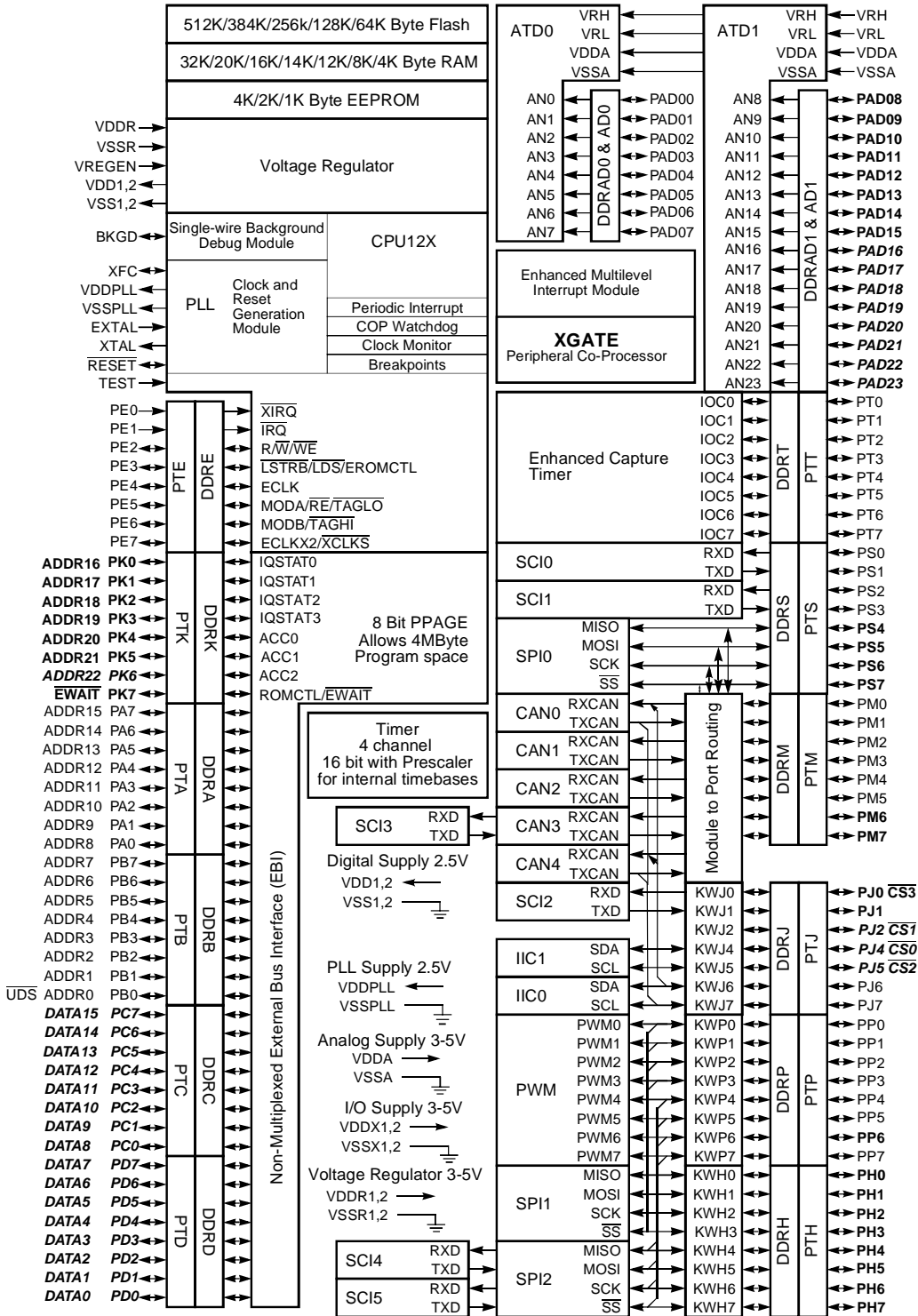

Signals shown in **Bold-Italics** are neither available on the 112 Pin nor on the 80 Pin Package Option
 Signals shown in **Bold** are not available on the 80 Pin Package

Table 1. Package and Memory Options of MC9S12XD Family Members

Device	Package	Flash	RAM	EEPROM	ROM
9S12XDP512	144 LQFP	512K	32K	4K	
	112 LQFP		20K		
9S12XDT512	144 LQFP	384K			
	112 LQFP				
	80 QFP				
9S12XDT384	144 LQFP	256K	16K		
	112 LQFP				
	80 QFP				
9S12XDQ256	144 LQFP	256K	14K		
	112 LQFP				
	80 QFP				
9S12XDT256	144 LQFP	256K	16K		
	112 LQFP				
	80 QFP				
9S12XD256	144 LQFP	256K	14K		
	112 LQFP				
	80 QFP				
3S12XDT256	144 LQFP		16K	(1)	256K
	112 LQFP				
	80 QFP				
9S12XDG128	112 LQFP	128K	12K	2K	
	80 QFP				
3S12XDG128	112 LQFP		12K	(1)	128K
	80 QFP				
9S12XD128	112 LQFP	128K	8K	2K	
	80 QFP				
9S12XD64	80 QFP	64K	4K	1K	

NOTES:

1. No EEPROM is available on ROM versions.

Table 2. Peripheral Options of MC9S12XD Family Members

Device	Package	XGATE	CAN	SCI	SPI	IIC	ECT	PIT	A/D	I/O
9S12XDP512	144LQFP	yes	5	6	3	2	8	4	2/24	119
	112LQFP		5	4	3	1	8	4	2/16	91
9S12XDT512	144LQFP		3	6	3	1	8	4	2/24	119
	112LQFP		3	4	3	1	8	4	2/16	91
	80QFP		3	2	2	1	8	4	1/8	59
9S12XDT384	144LQFP		3	4	3	1	8	4	2/24	119
	112LQFP		3	4	3	1	8	4	2/16	91
	80QFP		3	2	2	1	8	4	1/8	59
9S12XDQ256	144LQFP		4	4	3	1	8	4	2/24	119
	112LQFP		4	4	3	1	8	4	2/16	91
	80QFP		4	2	2	1	8	4	1/8	59
9S12XDT256	144LQFP		3	4	3	1	8	4	2/24	119
	112LQFP		3	4	3	1	8	4	2/16	91
	80QFP		3	2	2	1	8	4	1/8	59
9S12XD256	144LQFP		1	4	2	1	8	4	2/24	119
	112LQFP		1	4	2	1	8	4	2/16	91
	80QFP		1	2	2	1	8	4	1/8	59
3S12XDT256	144LQFP		3	4	3	1	8	4	2/24	119
	112LQFP		3	4	3	1	8	4	2/16	91
	80QFP		3	2	2	1	8	4	1/8	59
9S12XDG128	112LQFP	yes ⁽¹⁾	2	2	2	1	8	4	1/16 ⁽²⁾	91
	80QFP		2	2	2	1	8	4	1/8	59
3S12XDG128	112LQFP		2	2	2	1	8	4	1/16 ⁽²⁾	91
	80QFP		2	2	2	1	8	4	1/8	59
9S12XD128	112LQFP		1	2	2	1	8	4	1/16 ⁽²⁾	91
	80QFP		1	2	2	1	8	4	1/8	59
9S12XD64	80QFP		1	2	2	1	8	2	1/8	59

NOTES:

1. Can execute code only from RAM
2. ATD1 routed to PAD00-15 instead of PAD08-23.

Pinout explanations:

- A/D is the number of modules/total number of A/D channels.
- I/O is the sum of ports capable to act as digital input or output.
 - 144 Pin Packages:
Port A = 8, B = 8, C=8, D=8, E = 6 + 2 input only,
H = 8, J = 7, K = 8, M = 8, P = 8, S = 8, T = 8, PAD = 24
25 inputs provide Interrupt capability (H =8, P= 8, J = 7, IRQ, XIRQ)
 - 112 Pin Packages:
Port A = 8, B = 8, E = 6 + 2 input only, H = 8, J = 4, K = 7, M = 8, P = 8, S = 8, T = 8, PAD = 16
22 inputs provide Interrupt capability (H =8, P= 8, J = 4, IRQ, XIRQ)
 - 80 Pin Packages:
Port A = 8, B = 8, E = 6 + 2 input only, J = 2, M = 6, P = 7, S = 4, T = 8, PAD = 8
11 inputs provide Interrupt capability (P= 7, J = 2, IRQ, XIRQ)
- CAN0 can be routed under software control from PM[1:0] to pins PM[3:2] or PM[5:4] or PJ[7:6].
- CAN4 pins are shared between IIC0 pins.
- CAN4 can be routed under software control from PJ[7:6] to pins PM[5:4] or PM[7:6].
- Versions with 5 CAN modules will have CAN0, CAN1, CAN2, CAN3 and CAN4
- Versions with 4 CAN modules will have CAN0, CAN1, CAN2 and CAN4
- Versions with 3 CAN modules will have CAN0, CAN1 and CAN4.
- Versions with 2 CAN modules will have CAN0 and CAN4.
- Versions with 1 CAN modules will have CAN0
- Versions with 2 SPI modules will have SPI0 and SPI1.
- Versions with 4 SCI modules will have SCI0, SCI1, SCI2 and SCI4.
- Versions with 2 SCI modules will have SCI0 and SCI1.
- Versions with 1 IIC module will have IIC0.
- SPI0 can be routed to either Ports PS[7:4] or PM[5:2].
- SPI1 pins are shared with PWM[3:0]; In 144 and 112-pin versions, SPI1 can be routed under software control to PH[3:0].
- SPI2 pins are shared with PWM[7:4]; In 144 and 112-pin versions, SPI2 can be routed under software control to PH[7:4]. In 80-pin packages, \overline{SS} -signal of SPI2 is not bonded out!

Pin Assignments

Table 3. Port and Peripheral Availability by Package Option

Port	144 LQFP	112 LQFP	80 QFP
Port AD/ADC Channels	24/24	16/16	8/8
Port A pins	8	8	8
Port B pins	8	8	8
Port C pins	8	0	0
Port D pins	8	0	0
Port E pins incl. IRQ/XIRQ input only	8	8	8
Port H pins	8	8	0
Port J pins	7	4	2
Port K pins	8	7	0
Port M pins	8	8	6
Port P pins	8	8	7
Port S pins	8	8	4
Port T pins	8	8	8
Sum of Ports	119	91	59
VDDX/VSSX	4/4	3/3	2/2

Table 4. Peripheral–Port Cross Reference⁽¹⁾

	CAN0	CAN1	CAN2	CAN3	CAN4	SCI0	SCI1	SCI2	SCI3	SCI4	SCI5	SPI0	SPI1	SPI2	IIC0	IIC1
PJ1:0								X								
PJ3:2																
PJ5:4																X
PJ7:6	O				X										X	
PM1:0	X															
PM3:2	O	X										O				
PM5:4	O		X									O				
PM7:6				X	O				X							
PS1:0						X										
PS3:2							X									
PS7:4												X				
PH3:0													O			

Table 4. Peripheral–Port Cross Reference⁽¹⁾

	CAN0	CAN1	CAN2	CAN3	CAN4	SCI0	SCI1	SCI2	SCI3	SCI4	SCI5	SPI0	SPI1	SPI2	IIC0	IIC1
PH5:4										X				O		
PH7:6											X			O		
PP3:0													X			
PP7:4														X		

NOTES:

1. X denotes the reset condition and O denotes a possible rerouting under software control

Table 5. Pin-Out Summary⁽¹⁾

LQFP 144	LQFP 112	QFP 80	Pin	2nd Function	3rd Function	4th Function	5th Function
1	1	1	PP3	KWP3	PWM3	SS1	
2	2	2	PP2	KWP2	PWM2	SCK1	
3	3	3	PP1	KWP1	PWM1	MOSI1	
4	4	4	PP0	KWP0	PWM0	MISO1	
5			PJ2	KWJ2	CS1		
6			PK6	ADDR22	NOACC		
7	5		PK3	ADDR19			
8	6		PK2	ADDR18	IQSTAT2		
9	7		PK1	ADDR17	IQSTAT1		
10	8		PK0	ADDR16	IQSTAT0		
11	9	5	PT0	IOC0			
12	10	6	PT1	IOC1			
13	11	7	PT2	IOC2			
14	12	8	PT3	IOC3			
15	13	9	VDD1				
16	14	10	VSS1				
17	15	11	PT4	IOC4			
18	16	12	PT5	IOC5			
19	17	13	PT6	IOC6			
20	18	14	PT7	IOC7			
21	19		PK5	ADDR21			
22	20		PK4	ADDR20			
23	21		PJ1	KWJ1	TXD2		
24	22		PJ0	KWJ0	RXD2		

Pin Assignments

Table 5. Pin-Out Summary⁽¹⁾

LQFP 144	LQFP 112	QFP 80	Pin	2nd Function	3rd Function	4th Function	5th Function
25	23	15	BKGD	MODC			
26			VDDX2				
27			VSSX2				
28			PC0	DATA8			
29			PC1	DATA9			
30			PC2	DATA10			
31			PC3	DATA11			
32	24	16	PB0	ADDR0	\overline{UDS}		
33	25	17	PB1	ADDR1			
34	26	18	PB2	ADDR2			
35	27	19	PB3	ADDR3			
36	28	20	PB4	ADDR4			
37	29	21	PB5	ADDR5			
38	30	22	PB6	ADDR6			
39	31	23	PB7	ADDR7			
40			PC4	DATA12			
41			PC5	DATA13			
42			PC6	DATA14			
43			PC7	DATA15			
44	32		PH7	KWH7	$\overline{SS2}$	TXD5	
45	33		PH6	KWH6	SCK2	RXD5	
46	34		PH5	KWH5	MOSI2	TXD4	
47	35		PH4	KWH4	MISO2	RXD4	
48	36	24	PE7	XCLKS	ECLKX2		
49	37	25	PE6	MODB	\overline{TAGHI}		
50	38	26	PE5	MODA	\overline{TAGLO}	\overline{RE}	
51	39	27	PE4	ECLK			
52	40	28	VSSR				
53	41	29	VDDR				
54	42	30	\overline{RESET}				
55	43	31	VDDPLL				
56	44	32	XFC				
57	45	33	VSSPLL				
58	46	34	EXTAL				
59	47	35	XTAL				
60	48	36	TEST				
61	49		PH3	KWH3	$\overline{SS1}$	TXD7	

MC9S12XD Family, Rev. 2.14

Table 5. Pin-Out Summary⁽¹⁾

LQFP 144	LQFP 112	QFP 80	Pin	2nd Function	3rd Function	4th Function	5th Function
62	50		PH2	KWH2	SCK1	RXD7	
63	51		PH1	KWH1	MOSI1	TXD6	
64	52		PH0	KWH0	MISO1	RXD6	
65			PD0	DATA0			
66			PD1	DATA1			
67			PD2	DATA2			
68			PD3	DATA3			
69	53	37	PE3	LSTRB	$\overline{\text{LDS}}$	EROMCTL	
70	54	38	PE2	$\overline{\text{RW}}$	$\overline{\text{WE}}$		
71	55	39	PE1	$\overline{\text{IRQ}}$			
72	56	40	PE0	$\overline{\text{XIRQ}}$			
73	57	41	PA0	ADDR8			
74	58	42	PA1	ADDR9			
75	59	43	PA2	ADDR10			
76	60	44	PA3	ADDR11			
77	61	45	PA4	ADDR12			
78	62	46	PA5	ADDR13			
79	63	47	PA6	ADDR14			
80	64	48	PA7	ADDR15			
81			VDDX3				
82			VDDX3				
83			PD4	DATA4			
84			PD5	DATA5			
85			PD6	DATA6			
86			PD7	DATA7			
87	65	49	VDD2				
88	66	50	VSS2				
89	67	51	PAD00	AN0			
90	68		PAD08	AN8			
91	69	52	PAD01	AN1			
92	70		PAD09	AN9			
93	71	53	PAD02	AN2			
94	72		PAD10	AN8			
95	73	54	PAD03	AN3			
96	74		PAD11	AN11			
97	75	55	PAD04	AN4			
98	76		PAD12	AN12			

MC9S12XD Family, Rev. 2.14

Pin Assignments

Table 5. Pin-Out Summary⁽¹⁾

LQFP 144	LQFP 112	QFP 80	Pin	2nd Function	3rd Function	4th Function	5th Function
99	77	56	PAD05	AN5			
100	78		PAD13	AN13			
101	79	57	PAD06	AN6			
102	80		PAD14	AN14			
103	81	58	PAD07	AN7			
104	82		PAD15	AN15			
105			PAD16	AN16			
106			PAD17	AN17			
107	83	59	VDDA				
108	84	60	VRH				
109	85	61	VRL				
110	86	62	VSSA				
111			PAD18	AN18			
112			PAD19	AN19			
113			PAD20	AN20			
114			PAD21	AN21			
115			PAD22	AN22			
116			PAD23	AN23			
117	87		PM7	TXCAN3	TXCAN4	TXD3	
118	88		PM6	RXCAN3	RXCAN4	RXD3	
119	89	63	PS0	RXD0			
120	90	64	PS1	TXD0			
121	91	65	PS2	RXD1			
122	92	66	PS3	TXD1			
123	93		PS4	MISO0			
124	94		PS5	MOSI0			
125	95		PS6	SCK0			
126	96		PS7	$\overline{SS0}$			
127	97	67	VREGEN				
128	98	68	PJ7	KWJ7	TXCAN4	SCL0	
129	99	69	PJ6	KWJ6	RXCAN4	SDA0	
130			PJ5	KWJ5	SCL1	$\overline{CS2}$	
131			PJ4	KWJ4	SDA1	$\overline{CS0}$	
132	100	70	PM5	TXCAN2	TXCAN0	TXCAN4	SCK0
133	101	71	PM4	RXCAN2	RXCAN0	RXCAN4	MOSI0
134	102	72	PM3	TXCAN1	TXCAN0	$\overline{SS0}$	
135	103	73	PM2	RXCAN1	RXCAN0	MISO0	

MC9S12XD Family, Rev. 2.14

Table 5. Pin-Out Summary⁽¹⁾

LQFP 144	LQFP 112	QFP 80	Pin	2nd Function	3rd Function	4th Function	5th Function
136	104	74	PM1	TXCAN0			
137	105	75	PM0	RXCAN0			
138	106	76	VSSX1				
139	107	77	VDDX1				
140	108		PK7	ROMCTL	$\overline{\text{EWAIT}}$		
141	109	78	PP7	KWP7	PWM7	SCK2	
142	110		PP6	KWP6	PWM6	$\overline{\text{SS2}}$	
143	111	79	PP5	KWP5	PWM5	MOSI2	
144	112	80	PP4	KWP4	PWM4	MISO2	

NOTES:

1. Table shows a superset of pin functions. Not all functions are available on all derivatives

Pin Assignments

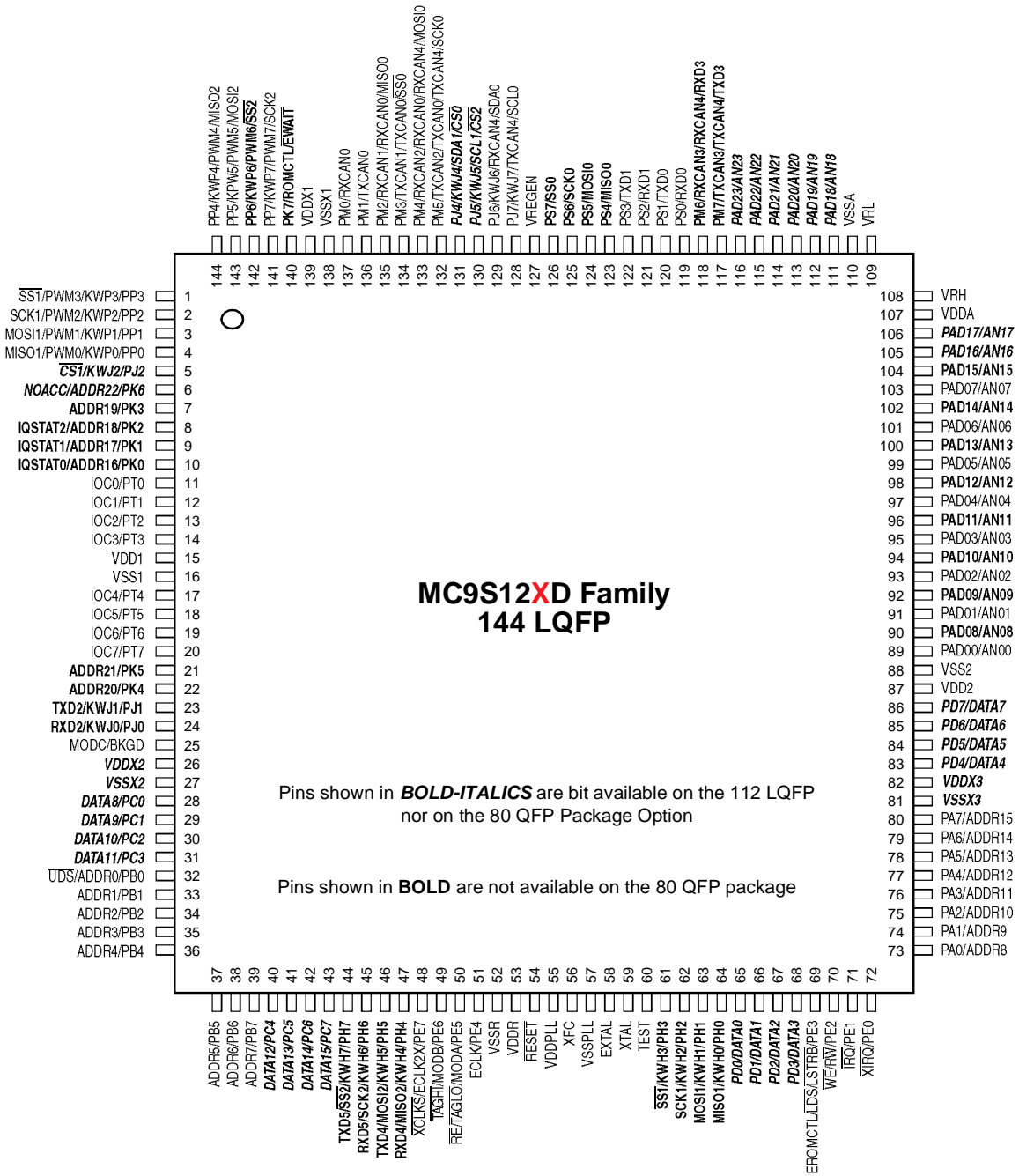

Figure 1. MC9S12XD Family Pin Assignments for 144-pin LQFP Package

MC9S12XD Family, Rev. 2.14

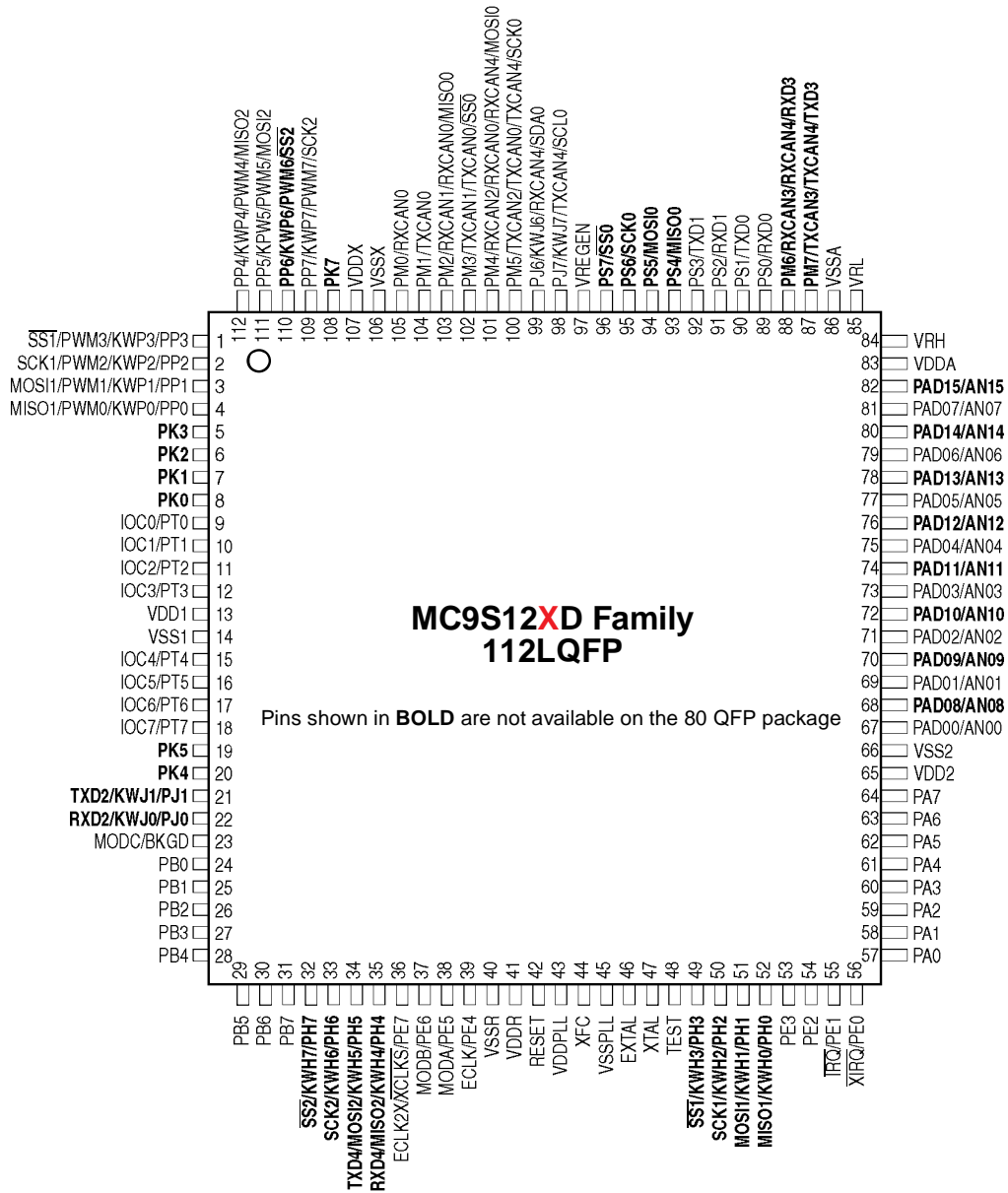

Figure 2. MC9S12XD Family Pin Assignments for 112-pin LQFP Package

Pin Assignments

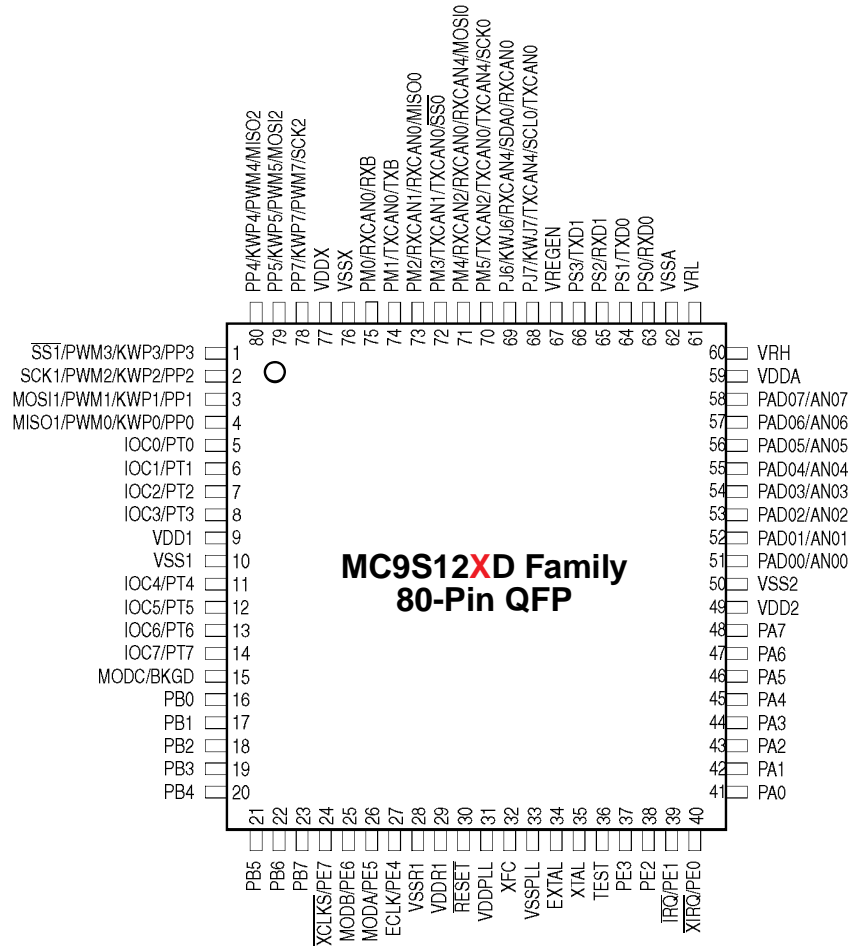

Figure 3. MC9S12XD Family Pin Assignments for 80-pin QFP Package

Memory Maps

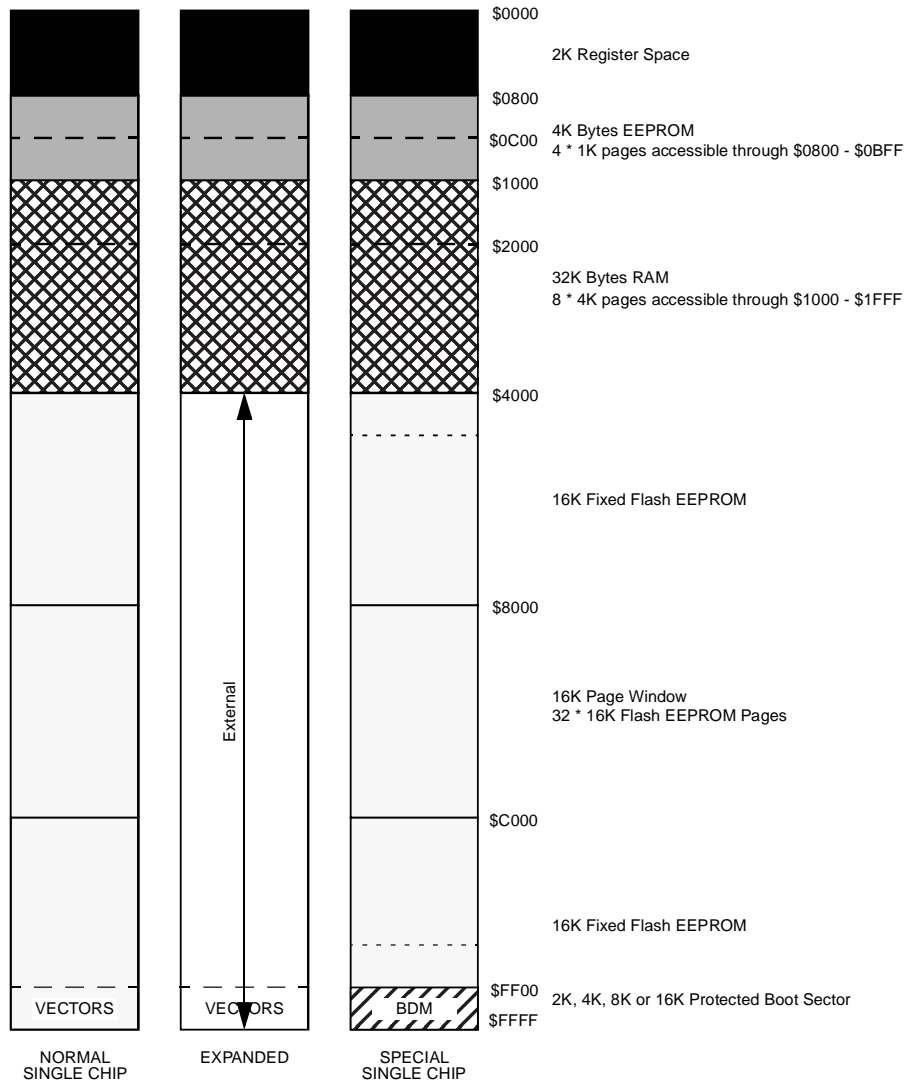

Figure 4. MC9S12XD-Family Memory Map¹

1. The memory Map shows the memory sizes of DP512 part. For memory configuration of other parts see Table 1.

Memory Maps

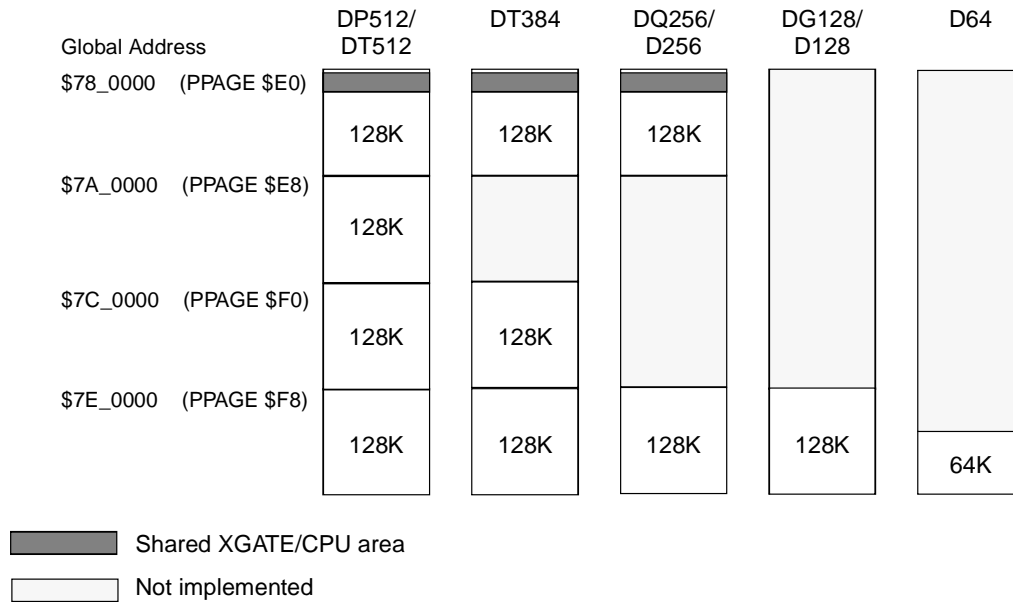

Figure 5. MC9S12XD-Family Flash Configuration^{1, 2, 3, 4, 5}

1. XGATE read access to Flash not possible on DG128/D128 and D64
2. Program Pages available on DT384 are \$E0 - \$E7 and \$F0 - \$FF
3. Program Pages available on DQ256/D256 are \$E0 - \$E7 and \$F8 - \$FF
4. Shared XGATE/CPU area on DP512/DT512/DT384 at global address \$78_0800 to \$78_FFFF (30Kbyte)
5. Shared XGATE/CPU area on DQ256/D256 at global address \$78_0800 to \$79_3FFF (46Kbyte)

Mechanical Package Dimensions

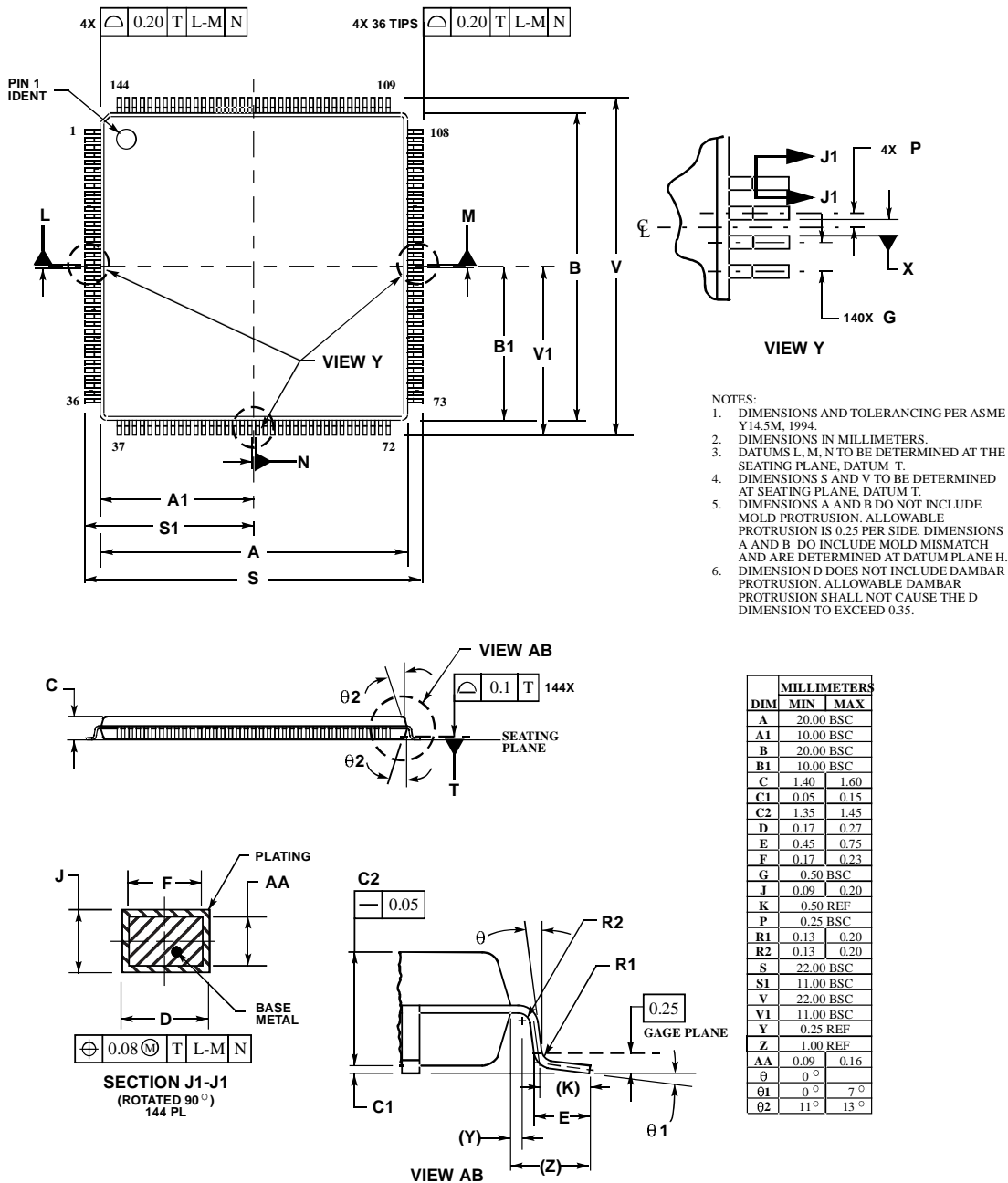

Figure 6. 144-pin LQFP Mechanical Dimensions (case no. 918-03)

MC9S12XD Family, Rev. 2.14

Mechanical Package Dimensions

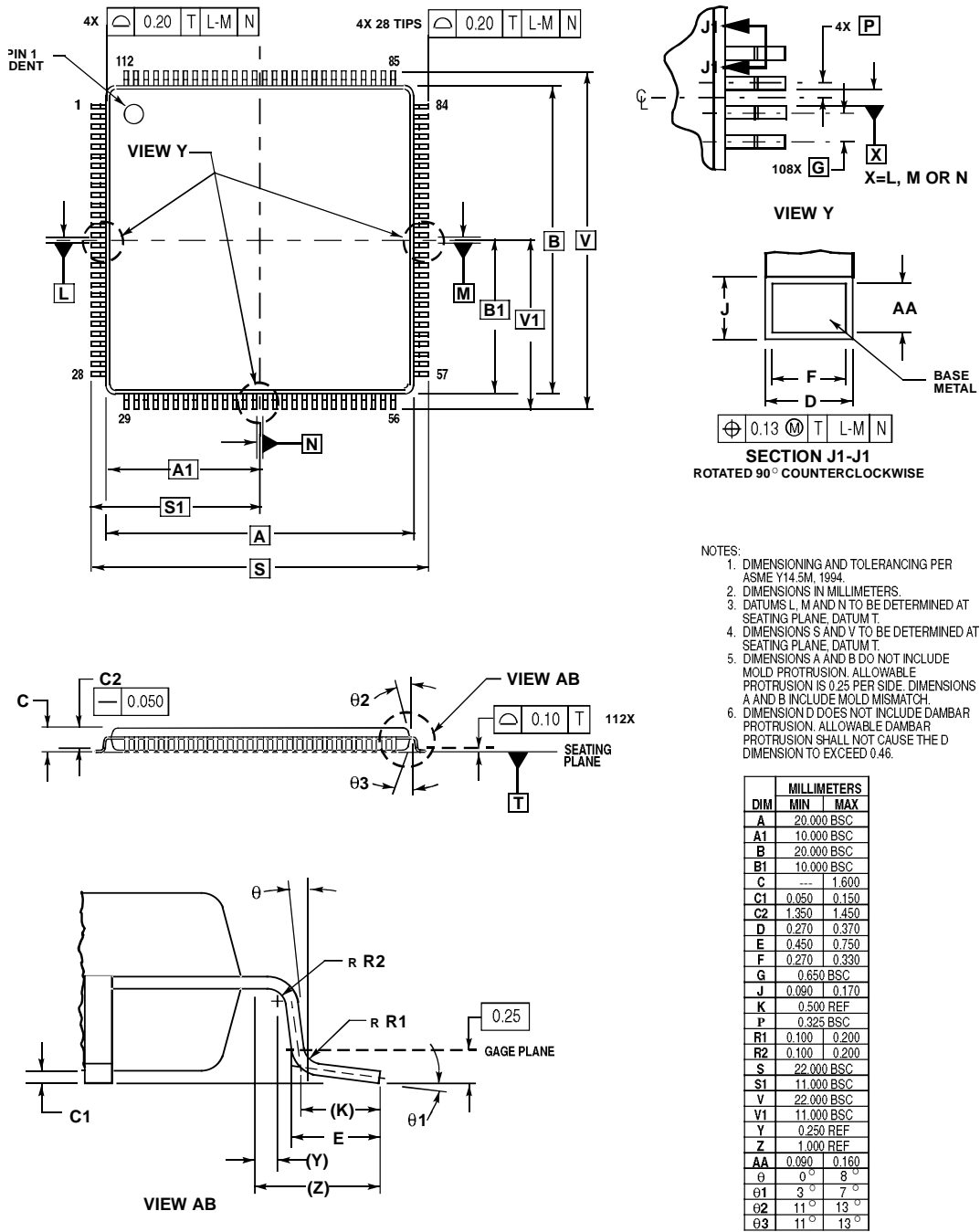
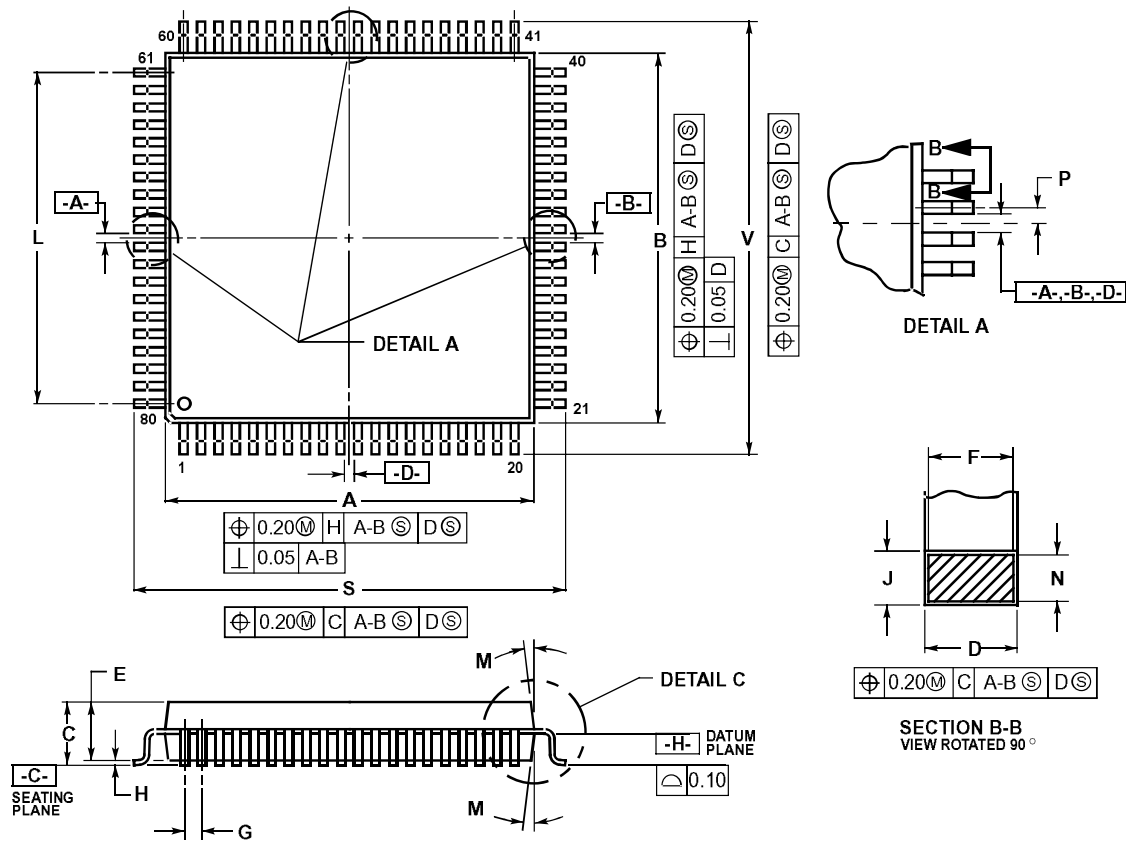

Figure 7. 112-pin LQFP Mechanical Dimensions (case no. 987)



- NOTES:
1. DIMENSIONING AND TOLERANCING PER ANSI Y14.5M, 1982.
 2. CONTROLLING DIMENSION: MILLIMETER.
 3. DATUM PLANE -H- IS LOCATED AT BOTTOM OF LEAD AND IS COINCIDENT WITH THE LEAD WHERE THE LEAD EXITS THE PLASTIC BODY AT THE BOTTOM OF THE PARTING LINE.
 4. DATUMS -A-, -B- AND -D- TO BE DETERMINED AT DATUM PLANE -H-.
 5. DIMENSIONS S AND V TO BE DETERMINED AT SEATING PLANE -C-.
 6. DIMENSIONS A AND B DO NOT INCLUDE MOLD PROTRUSION. ALLOWABLE PROTRUSION IS 0.25 PER SIDE. DIMENSIONS A AND B DO INCLUDE MOLD MISMATCH AND ARE DETERMINED AT DATUM PLANE -H-.
 7. DIMENSION D DOES NOT INCLUDE DAMBAR PROTRUSION. ALLOWABLE DAMBAR PROTRUSION SHALL BE 0.08 TOTAL IN EXCESS OF THE D DIMENSION AT MAXIMUM MATERIAL CONDITION. DAMBAR CANNOT BE LOCATED ON THE LOWER RADIUS OR THE FOOT.

DIM	MILLIMETERS	
	MIN	MAX
A	13.90	14.10
B	13.90	14.10
C	2.15	2.45
D	0.22	0.38
E	2.00	2.40
F	0.22	0.33
G	0.65 BSC	
H	---	0.25
J	0.13	0.23
K	0.65	0.95
L	12.35 REF	
M	5°	10°
N	0.13	0.17
P	0.325 BSC	
Q	0°	7°
R	0.13	0.30
S	16.95	17.45
T	0.13	---
U	0°	---
V	16.95	17.45
W	0.35	0.45
X	1.6 REF	

Figure 8. 80-pin QFP Mechanical Dimensions (case no. 841B)

How to Reach Us:

Home Page:

www.freescale.com

E-mail:

support@freescale.com

USA/Europe or Locations Not Listed:

Freescale Semiconductor
Technical Information Center, CH370
1300 N. Alma School Road
Chandler, Arizona 85224
+1-800-521-6274 or +1-480-768-2130
support@freescale.com

Europe, Middle East, and Africa:

Freescale Halbleiter Deutschland GmbH
Technical Information Center
Schatzbogen 7
81829 Muenchen, Germany
+44 1296 380 456 (English)
+46 8 52200080 (English)
+49 89 92103 559 (German)
+33 1 69 35 48 48 (French)
support@freescale.com

Japan:

Freescale Semiconductor Japan Ltd.
Headquarters
ARCO Tower 15F
1-8-1, Shimo-Meguro, Meguro-ku,
Tokyo 153-0064
Japan
0120 191014 or +81 3 5437 9125
support.japan@freescale.com

Asia/Pacific:

Freescale Semiconductor Hong Kong Ltd.
Technical Information Center
2 Dai King Street
Tai Po Industrial Estate
Tai Po, N.T., Hong Kong
+800 2666 8080
support.asia@freescale.com

For Literature Requests Only:

Freescale Semiconductor Literature Distribution Center
P.O. Box 5405
Denver, Colorado 80217
1-800-441-2447 or 303-675-2140
Fax: 303-675-2150
LDCForFreescaleSemiconductor@hibbertgroup.com

Information in this document is provided solely to enable system and software implementers to use Freescale Semiconductor products. There are no express or implied copyright licenses granted hereunder to design or fabricate any integrated circuits or integrated circuits based on the information in this document.

Freescale Semiconductor reserves the right to make changes without further notice to any products herein. Freescale Semiconductor makes no warranty, representation or guarantee regarding the suitability of its products for any particular purpose, nor does Freescale Semiconductor assume any liability arising out of the application or use of any product or circuit, and specifically disclaims any and all liability, including without limitation consequential or incidental damages. "Typical" parameters that may be provided in Freescale Semiconductor data sheets and/or specifications can and do vary in different applications and actual performance may vary over time. All operating parameters, including "Typicals", must be validated for each customer application by customer's technical experts. Freescale Semiconductor does not convey any license under its patent rights nor the rights of others. Freescale Semiconductor products are not designed, intended, or authorized for use as components in systems intended for surgical implant into the body, or other applications intended to support or sustain life, or for any other application in which the failure of the Freescale Semiconductor product could create a situation where personal injury or death may occur. Should Buyer purchase or use Freescale Semiconductor products for any such unintended or unauthorized application, Buyer shall indemnify and hold Freescale Semiconductor and its officers, employees, subsidiaries, affiliates, and distributors harmless against all claims, costs, damages, and expenses, and reasonable attorney fees arising out of, directly or indirectly, any claim of personal injury or death associated with such unintended or unauthorized use, even if such claim alleges that Freescale Semiconductor was negligent regarding the design or manufacture of the part.

Freescale™ and the Freescale logo are trademarks of Freescale Semiconductor, Inc. All other product or service names are the property of their respective owners.

© Freescale Semiconductor, Inc. 2005. All rights reserved.