

Freescale Semiconductor Data Sheet: Advance Information

An Energy Efficient Solution by Freescale

MC9S08GW64 Series

Covers: MC9S08GW64 and
MC9S08GW32

Document Number: MC9S08GW64

Rev. 1, 5/2010

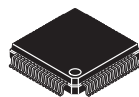

80-LQFP
Case 917A
14 × 14

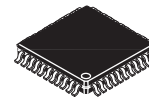

64-LQFP
Case 840F
10 × 10

comparator can be used as hardware breakpoint. Full mode, Comparator A compares address and Comparator B compares data. Supports both tag and force breakpoints

8-Bit HCS08 Central Processor Unit (CPU)

- New version of S08 core with same performance as traditional S08 and lower power
- Up to 20 MHz CPU at 3.6 V to 2.15 V and up to 10 MHz CPU at 2.15 V to 1.8 V, across temperature range of -40°C to 85°C
- HC08 instruction set with added BGND instruction
- Support for up to 48 interrupt/reset sources

On-Chip Memory

- Flash read/program/erase over full operating voltage and temperature
- Random-access memory (RAM)
- Security circuitry to prevent unauthorized access to RAM and flash contents

Power-Saving Modes

- Two low power stop modes and reduced power wait mode
- Low power run and wait modes allow peripherals to run while voltage regulator is in standby
- Peripheral clock gating register can disable clocks to unused modules, thereby reducing currents
- Very low power external oscillator that can be used in stop2 or stop3 modes to provide accurate clock source to real time counter
- 6 μs typical wakeup time from stop3 mode

Clock Source Options

- Oscillator (XOSC1) — Loop-control Pierce oscillator; Crystal or ceramic resonator of 32.768 kHz; Clock source for iRTC or ICS
- Oscillator (XOSC2) — Loop-control Pierce oscillator; Crystal or ceramic resonator range of 31.25 kHz to 38.4 kHz or 1 MHz to 16 MHz; optional clock source for ICS
- Internal Clock Source (ICS) — Internal clock source module containing a frequency-locked-loop (FLL) controlled by internal or external reference (XOSC1, XOSC2); precision trimming of internal reference allows 0.2% resolution and 2% deviation over temperature and voltage; supporting CPU/bus frequencies from 1 MHz to 20 MHz

System Protection

- Watchdog computer operating properly (COP) reset with option to run from dedicated 1 kHz internal clock source or bus clock
- Low-voltage warning with interrupt
- Low-voltage detection with reset or interrupt
- Illegal opcode and illegal address detection with reset
- Flash block protection

Development Support

- Single-wire background debug interface
- Breakpoint capability to allow single breakpoint setting during in-circuit debugging (plus 3 more breakpoints in breakpoint unit)
- Breakpoint (BKPT) debug module containing three comparators (A, B, and C) with ability to match addresses in 64 KB space. Each

This document contains information on a product under development. Freescale reserves the right to change or discontinue this product without notice.

© Freescale Semiconductor, Inc., 2010. All rights reserved.

PRELIMINARY-SUBJECT TO CHANGE WITHOUT NOTICE

Peripherals

- **LCD** — up to 4×40 or 8×36 LCD driver with internal charge pump and option to provide an internally regulated LCD reference that can be trimmed for contrast control
- **ADC16** — two analog-to-digital converters; 16-bit resolution; one dedicated differential per ADC; up to 16-ch; up to 2.5 μs conversion time for 12-bit mode; automatic compare function; hardware averaging; calibration registers; temperature sensor; internal bandgap reference channel; operation in stop3; fully functional from 3.6 V to 1.8 V
- **PRACMP** — three rail to rail programmable reference analog comparator; up to 8 inputs; on-chip programmable reference generator output; selectable interrupt on rising, falling, or either edge of comparator output; operation in stop3
- **SCI** — four full duplex non-return to zero (NRZ); LIN master extended break generation; LIN slave extended break detection; wakeup on active edge; SCI0 designed for AMR operation; TxD of SCI1 and SCI2 can be modulated with timers and RxD can be received through PRACMP;
- **SPI** — three full-duplex or single-wire bidirectional; double-buffered transmit and receive; master or slave mode; MSB-first or LSB-first shifting; SPI0 designed for AMR operation
- **IIC** — up to 100 kbps with maximum bus loading; multi-master operation; programmable slave address; interrupt driven byte-by-byte data transfer; supporting broadcast mode and 10-bit addressing; supporting SM BUS functionality; can wake from stop3
- **FTM** — 2-channel FTMs; selectable input capture, output compare, or buffered edge- or center-aligned PWM on each channel
- **IRTC** — independent real-time clock, independent power domain, 32 bytes RAM, 32.768 kHz input clock optional output to ICS, hardware calendar, hardware compensation due to crystal or temperature characteristics, tamper detection and indicator
- **PCRC** — 16/32 bit programmable cyclic redundancy check for high-speed CRC calculation
- **MTIM** — two 8-bit and one 16-bit timers; configurable clock inputs and interrupt generation on overflow
- **PDB** — programmable delay block; optimized for scheduling ADC conversions
- **PCNT** — position counter; working in stop3 mode without waking CPU; can be used to generate waveforms like timer

Input/Output

- 57 GPIOs including one output-only pin
- Eight KBI interrupts with selectable polarity
- Hysteresis and configurable pullup device on all input pins; configurable slew rate and drive strength on all output pins.

Package Options

- 80-pin LQFP, 64-pin LQFP



Table of Contents

1	Devices in the MC9S08GW64 Series	3	3.10.1 Control Timing	24
2	Pin Assignments	6	3.10.2 Timer (TPM/FTM) Module Timing	25
3	Electrical Characteristics	10	3.10.3 SPI Timing	26
3.1	Introduction	10	3.11 Analog Comparator (PRACMP) Electricals	29
3.2	Parameter Classification	10	3.12 ADC Characteristics	29
3.3	Absolute Maximum Ratings	10	3.13 VREF Characteristics	34
3.4	Thermal Characteristics	11	3.14 LCD Specifications	35
3.5	ESD Protection and Latch-Up Immunity	12	3.15 FLASH Specifications	35
3.6	DC Characteristics	13	4 Ordering Information	36
3.7	Supply Current Characteristics	18	4.1 Device Numbering System	36
3.8	External Oscillator (XOSCVLP) Characteristics	20	5 Package Information and Mechanical Drawings	36
3.9	Internal Clock Source (ICS) Characteristics	21		
3.10	AC Characteristics	23		

Revision History

To provide the most up-to-date information, the revision of our documents on the World Wide Web will be the most current. Your printed copy may be an earlier revision. To verify you have the latest information available, refer to:

<http://freescale.com/>

The following revision history table summarizes changes contained in this document.

Rev	Date	Description of Changes
1	5/26/2010	Initial public release

Related Documentation

Find the most current versions of all documents at: <http://www.freescale.com>

Reference Manual (MC9S08GW64RM)

Contains extensive product information including modes of operation, memory, resets and interrupts, register definition, port pins, CPU, and all module information.

1 Devices in the MC9S08GW64 Series

Table 1 summarizes the feature set available in the MC9S08GW64 series of MCUs.

Table 1. MC9S08GW64 Series Features by MCU and Package

Feature	MC9S08GW64		MC9S08GW32	
	80-pin LQFP	64-pin LQFP	80-pin LQFP	64-pin LQFP
FLASH	65,536 Bytes		32,768 Bytes	
RAM	4,032 Bytes		2,048 Bytes	
ADC0 ¹ Single-ended Channels	7-ch	7-ch	7-ch	7-ch
ADC0 Differential Channels ²	1	0	1	0
ADC1 Single-ended Channels	7-ch	7-ch	7-ch	7-ch
ADC1 Differential Channels	1	1	1	1
BKPT	yes		yes	
ICS	yes		yes	
IIC	yes		yes	
IRQ	yes		yes	
IRTC	yes		yes	
KBI	8-ch		8-ch	
MTIM8	2		2	
MTIM16	yes		yes	
PCNT	yes		yes	
PCRC	yes		yes	
PDB	yes		yes	
PRACMP	3		3	
SCI	4		4	
SPI	3		3	
FTM	2-ch		2-ch	
LCD	8×36 4×40	8×24 4×28	8×36 4×40	8×24 4×28
VREFO	yes	yes	yes	yes
XOSC	2		2	
I/O pins ³	57	45	57	45

Devices in the MC9S08GW64 Series

- ¹ There are two 16-bit ADC modules, so two parallel conversions at two channels can be made simultaneously.
- ² Each differential channel consists of two pins (DADPx and DADMx).
- ³ The I/O pins include one output-only pin.

The block diagram in [Figure 1](#) shows the structure of the MC9S08GW64 series MCUs.

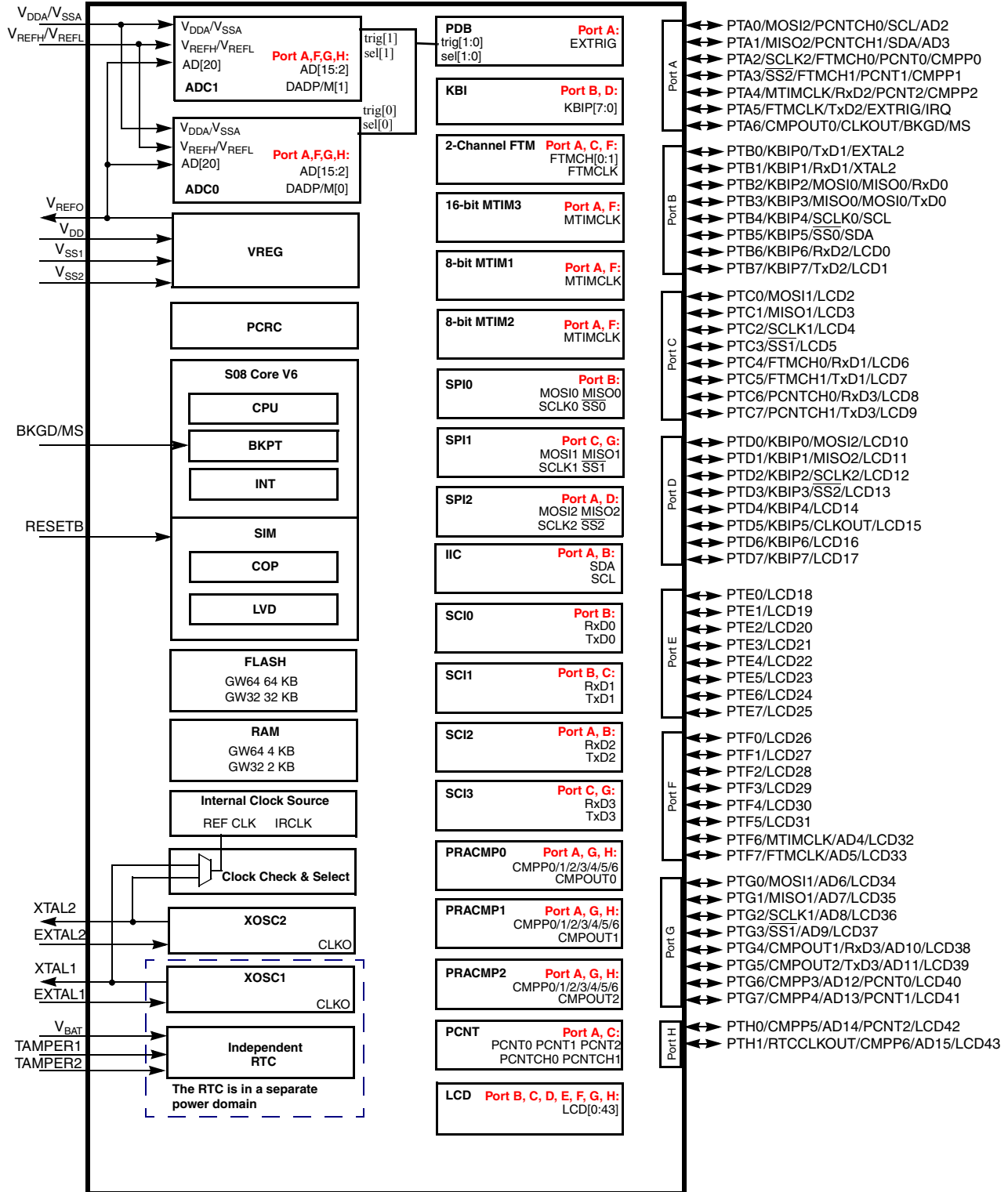

Figure 1. MC9S08GW64 Series Block Diagram

2 Pin Assignments

This section shows the pin assignments for the MC9S08GW64 series devices.

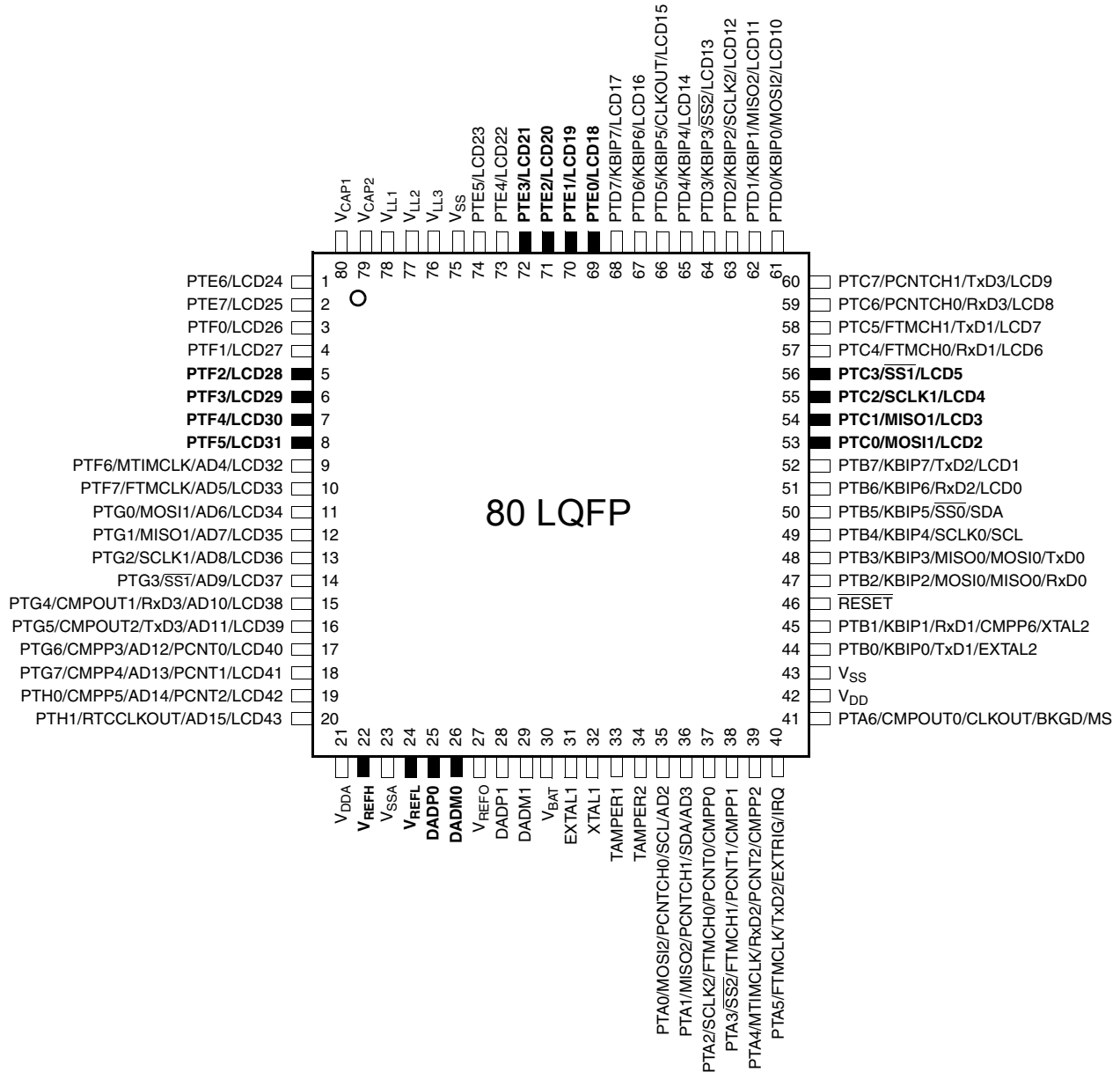

Figure 2. MC9S08GW64 Series in 80-Pin LQFP Package

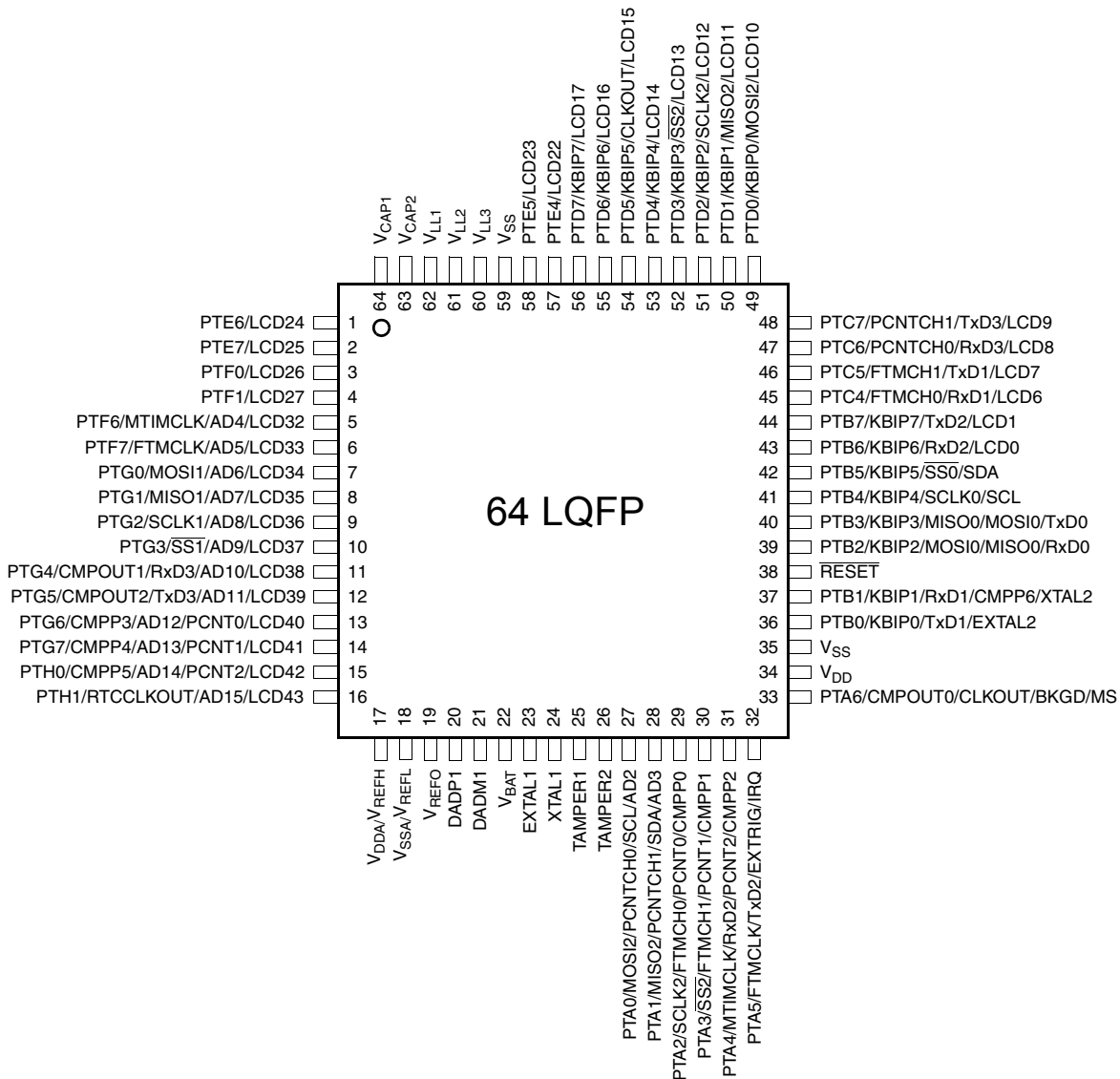

Figure 3. MC9S08GW64 Series in 64-Pin LQFP Package

Table 2. Pin Availability by Package Pin-Count

80	64	Port Pin	Default func	Alt 1	Alt 2	Alt3	Alt4
1	1	PTE6	PTE6		LCD24		
2	2	PTE7	PTE7		LCD25		
3	3	PTF0	PTF0	LCD26			
4	4	PTF1	PTF1	LCD27			
5		PTF2	PTF2	LCD28			
6		PTF3	PTF3	LCD29			

Table 2. Pin Availability by Package Pin-Count (continued)

80	64	Port Pin	Default func	Alt 1	Alt 2	Alt3	Alt4
7		PTF4	PTF4	LCD30			
8		PTF5	PTF5	LCD31			
9	5	PTF6	PTF6	MTIMCLK	AD4	LCD32	
10	6	PTF7	PTF7	FTMCLK	AD5	LCD33	
11	7	PTG0	PTG0	MOSI1	AD6	LCD34	
12	8	PTG1	PTG1	MISO1	AD7	LCD35	
13	9	PTG2	PTG2	SCLK1	AD8	LCD36	
14	10	PTG3	PTG3	$\overline{SS1}$	AD9	LCD37	
15	11	PTG4	PTG4	CMPOUT1	RxD3	AD10	LCD38
16	12	PTG5	PTG5	CMPOUT2	TxD3	AD11	LCD39
17	13	PTG6	PTG6	CMPP3	AD12	PCNT0	LCD40
18	14	PTG7	PTG7	CMPP4	AD13	PCNT1	LCD41
19	15	PTH0	PTH0	CMPP5	AD14	PCNT2	LCD42
20	16	PTH1	PTH1	RTCCLKOUT	AD15	LCD43	
21	17	V _{DDA}	V _{DDA}				
22		V _{REFH}	V _{REFH}				
23	18	V _{SSA}	V _{SSA}				
24		V _{REFL}	V _{REFL}				
25		DADP0	DADP0				
26		DADM0	DADM0				
27	19	V _{REFO}	V _{REFO}				
28	20	DADP1	DADP1				
29	21	DADM1	DADM1				
30	22	V _{BAT}	V _{BAT}				
31	23	EXTAL1	EXTAL1				
32	24	XTAL1	XTAL1				
33	25	TAMPER1 ¹	TAMPER1				
34	26	TAMPER2	TAMPER2				
35	27	PTA0	PTA0	MOSI2	PCNTCH0	SCL	AD2
36	28	PTA1	PTA1	MISO2	PCNTCH1	SDA	AD3
37	29	PTA2	PTA2	SCLK2	FTMCH0	PCNT0	CMPP0
38	30	PTA3	PTA3	$\overline{SS2}$	FTMCH1	PCNT1	CMPP1
39	31	PTA4	PTA4	MTIMCLK	RxD2	PCNT2	CMPP2
40	32	PTA5 ²	PTA5	FTMCLK	TxD2	EXTRIG	IRQ
41	33	PTA6 ³	BKGD/MS	CMPOUT0	CLKOUT	BKGD/MS	

Table 2. Pin Availability by Package Pin-Count (continued)

80	64	Port Pin	Default func	Alt 1	Alt 2	Alt3	Alt4
42	34	V _{DD}	V _{DD}				
43	35	V _{SS}	V _{SS}				
44	36	PTB0	PTB0	KBIP0	TxD1	EXTAL2	
45	37	PTB1 ¹	PTB1	KBIP1	RxD1	CMPP6	XTAL2
46	38	$\overline{\text{RESET}}$	$\overline{\text{RESET}}$				
47	39	PTB2	PTB2	KBIP2	MOSI0	MISO0	RxD0
48	40	PTB3 ⁴	PTB3	KBIP3	MISO0	MOSI0	TxD0
49	41	PTB4 ³	PTB4	KBIP4	SCLK0	SCL	
50	42	PTB5 ³	PTB5	KBIP5	$\overline{\text{SS0}}$	SDA	
51	43	PTB6	PTB6	KBIP6	RxD2	LCD0	
52	44	PTB7	PTB7	KBIP7	TxD2	LCD1	
53		PTC0	PTC0	MOSI1	LCD2		
54		PTC1	PTC1	MISO1	LCD3		
55		PTC2	PTC2	SCLK1	LCD4		
56		PTC3	PTC3	$\overline{\text{SS1}}$	LCD5		
57	45	PTC4	PTC4	FTMCH0	RxD1	LCD6	
58	46	PTC5	PTC5	FTMCH1	TxD1	LCD7	
59	47	PTC6	PTC6	PCNTCH0	RxD3	LCD8	
60	48	PTC7	PTC7	PCNTCH1	TxD3	LCD9	
61	49	PTD0	PTD0	KBIP0	MOSI2	LCD10	
62	50	PTD1	PTD1	KBIP1	MISO2	LCD11	
63	51	PTD2	PTD2	KBIP2	SCLK2	LCD12	
64	52	PTD3	PTD3	KBIP3	$\overline{\text{SS2}}$	LCD13	
65	53	PTD4	PTD4	KBIP4	LCD14		
66	54	PTD5	PTD5	KBIP5	CLKOUT	LCD15	
67	55	PTD6	PTD6	KBIP6	LCD16		
68	56	PTD7	PTD7	KBIP7	LCD17		
69		PTE0	PTE0	LCD18			
70		PTE1	PTE1	LCD19			
71		PTE2	PTE2	LCD20			
72		PTE3	PTE3	LCD21			
73	57	PTE4	PTE4		LCD22		
74	58	PTE5	PTE5		LCD23		
75	59	V _{SS}	V _{SS}				
76	60	V _{LL3}	V _{LL3}				

Table 2. Pin Availability by Package Pin-Count (continued)

80	64	Port Pin	Default func	Alt 1	Alt 2	Alt3	Alt4
77	61	V _{LL2}	V _{LL2}				
78	62	V _{LL1}	V _{LL1}				
79	63	V _{CAP2}	V _{CAP2}				
80	64	V _{CAP1}	V _{CAP1}				

¹ TAMPER0 pin is dedicatedly used for Battery Removal Tamper and not exposed on any SoC pins.

² PTA5 is with double drive strength.

³ PTA6 is an output-only pin when it is configured as GPIO.

⁴ PTB2, PTB3 and PTB4 are compatible with 5 V devices with a pullup device.

3 Electrical Characteristics

3.1 Introduction

This section contains electrical and timing specifications for the MC9S08GW64 sries of microcontrollers available at the time of publication.

3.2 Parameter Classification

The electrical parameters shown in this supplement are guaranteed by various methods. To give the customer a better understanding the following classification is used and the parameters are tagged accordingly in the tables where appropriate:

Table 3. Parameter Classifications

P	Those parameters are guaranteed during production testing on each individual device.
C	Those parameters are achieved by the design characterization by measuring a statistically relevant sample size across process variations.
T	Those parameters are achieved by design characterization on a small sample size from typical devices under typical conditions unless otherwise noted. All values shown in the typical column are within this category.
D	Those parameters are derived mainly from simulations.

NOTE

The classification is shown in the column labeled “C” in the parameter tables where appropriate.

3.3 Absolute Maximum Ratings

Absolute maximum ratings are stress ratings only, and functional operation at the maxima is not guaranteed. Stress beyond the limits specified in [Table 4](#) may affect device reliability or cause permanent damage to the device. For functional operating conditions, refer to the remaining tables in this section.

This device contains circuitry protecting against damage due to high static voltage or electrical fields; however, it is advised that normal precautions be taken to avoid application of any voltages higher than maximum-rated voltages to this

high-impedance circuit. Reliability of operation is enhanced if unused inputs are tied to an appropriate logic voltage level (for instance, either V_{SS} or V_{DD}) or the programmable pull-up resistor associated with the pin is enabled.

Table 4. Absolute Maximum Ratings

Rating	Symbol	Value	Unit
Supply voltage	V_{DD}	-0.3 to +3.8	V
Maximum current into V_{DD}	I_{DD}	120	mA
Digital input voltage	V_{In}	-0.3 to $V_{DD} + 0.3$	V
Instantaneous maximum current Single pin limit (applies to all port pins except PTA5 and PTB1) ^{1, 2, 3}	I_D	± 25	mA
Instantaneous maximum current Single pin limit (applies to PTA5 and PTB1) ^{1, 2, 3}	I_D	± 50	mA
Storage temperature range	T_{stg}	-55 to 150	°C

¹ Input must be current limited to the value specified. To determine the value of the required current-limiting resistor, calculate resistance values for positive (V_{DD}) and negative (V_{SS}) clamp voltages, then use the larger of the two resistance values.

² All functional non-supply pins are internally clamped to V_{SS} and V_{DD} .

³ Power supply must maintain regulation within operating V_{DD} range during instantaneous and operating maximum current conditions. If positive injection current ($V_{In} > V_{DD}$) is greater than I_{DD} , the injection current may flow out of V_{DD} and could result in external power supply going out of regulation. Ensure external V_{DD} load will shunt current greater than maximum injection current. This will be the greatest risk when the MCU is not consuming power. Examples are: if no system clock is present, or if the clock rate is very low (which would reduce overall power consumption).

3.4 Thermal Characteristics

This section provides information about operating temperature range, power dissipation, and package thermal resistance. Power dissipation on I/O pins is usually small compared to the power dissipation in on-chip logic and voltage regulator circuits, and it is user-determined rather than being controlled by the MCU design. To take $P_{I/O}$ into account in power calculations, determine the difference between actual pin voltage and V_{SS} or V_{DD} and multiply by the pin current for each I/O pin. Except in cases of unusually high pin current (heavy loads), the difference between pin voltage and V_{SS} or V_{DD} will be very small.

Table 5. Thermal Characteristics

Rating	Symbol	Value	Unit
Operating temperature range (packaged)	T_A	T_L to T_H -40 to 85	°C
Maximum junction temperature	T_J	95	°C
Thermal resistance Single-layer board			
80-pin LQFP	θ_{JA}	TBD	°C/W
64-pin LQFP		TBD	
Thermal resistance Four-layer board			
80-pin LQFP	θ_{JA}	TBD	°C/W
64-pin LQFP		TBD	

Electrical Characteristics

The average chip-junction temperature (T_J) in °C can be obtained from:

$$T_J = T_A + (P_D \times \theta_{JA}) \quad \text{Eqn. 1}$$

where:

T_A = Ambient temperature, °C

θ_{JA} = Package thermal resistance, junction-to-ambient, °C/W

$P_D = P_{int} + P_{I/O}$

$P_{int} = I_{DD} \times V_{DD}$, Watts — chip internal power

$P_{I/O}$ = Power dissipation on input and output pins — user determined

For most applications, $P_{I/O} \ll P_{int}$ and can be neglected. An approximate relationship between P_D and T_J (if $P_{I/O}$ is neglected) is:

$$P_D = K \div (T_J + 273^\circ\text{C}) \quad \text{Eqn. 2}$$

Solving Equation 1 and Equation 2 for K gives:

$$K = P_D \times (T_A + 273^\circ\text{C}) + \theta_{JA} \times (P_D)^2 \quad \text{Eqn. 3}$$

where K is a constant pertaining to the particular part. K can be determined from equation 3 by measuring P_D (at equilibrium) for a known T_A . Using this value of K, the values of P_D and T_J can be obtained by solving Equation 1 and Equation 2 iteratively for any value of T_A .

3.5 ESD Protection and Latch-Up Immunity

Although damage from electrostatic discharge (ESD) is much less common on these devices than on early CMOS circuits, normal handling precautions should be taken to avoid exposure to static discharge. Qualification tests are performed to ensure that these devices can withstand exposure to reasonable levels of static without suffering any permanent damage.

All ESD testing is in conformity with AEC-Q100 Stress Test Qualification for Automotive Grade Integrated Circuits. During the device qualification, ESD stresses were performed for the human body model (HBM), the machine model (MM) and the charge device model (CDM).

A device is defined as a failure if after exposure to ESD pulses the device no longer meets the device specification. Complete DC parametric and functional testing is performed per the applicable device specification at room temperature followed by hot temperature, unless instructed otherwise in the device specification.

Table 6. ESD and Latch-up Test Conditions

Model	Description	Symbol	Value	Unit
Human Body Model	Series resistance	R1	1500	Ω
	Storage capacitance	C	100	pF
	Number of pulses per pin	—	3	
Charge Device Model	Series resistance	R1	0	Ω
	Storage capacitance	C	200	pF
	Number of pulses per pin	—	3	
Latch-up	Minimum input voltage limit		-2.5	V
	Maximum input voltage limit		7.5	V

Table 7. ESD and Latch-Up Protection Characteristics

No.	Rating ¹	Symbol	Min	Max	Unit
1	Human body model (HBM)	V_{HBM}	± 1500	—	V
2	Machine Model (MM)	V_{MM}	± 200	—	V
3	Charge device model (CDM)	V_{CDM}	± 500	—	V
4	Latch-up current at $T_A = 85^\circ\text{C}$	I_{LAT}	± 100	—	mA

¹ Parameter is achieved by design characterization on a small sample size from typical devices under typical conditions unless otherwise noted.

3.6 DC Characteristics

This section includes information about power supply requirements and I/O pin characteristics.

Table 8. DC Characteristics

Num	C	Characteristic	Symbol	Condition	Min	Typ ¹	Max	Unit
1		Operating Voltage			1.8		3.6	V
2	C	Output high voltage All non-LCD pins low-drive strength	V_{OH}	$V_{DD} > 1.8\text{ V}$ $I_{Load} = -0.6\text{ mA}$	$V_{DD} - 0.5$	—	—	V
	P	All non-LCD pins high-drive strength		$V_{DD} > 2.7\text{ V}$ $I_{Load} = -10\text{ mA}$	$V_{DD} - 0.5$	—	—	
	C			$V_{DD} > 1.8\text{ V}$ $I_{Load} = -3\text{ mA}$	$V_{DD} - 0.5$	—	—	
3	C	Output high voltage All LCD/GPIO pins low-drive strength	V_{OH}	$V_{DD} > 1.8\text{ V}$ $I_{Load} = -0.5\text{ mA}$	$V_{DD} - 0.5$	—	—	V
	P	All LCD/GPIO pins high-drive strength		$V_{DD} > 2.7\text{ V}$ $I_{Load} = -2.5\text{ mA}$	$V_{DD} - 0.5$	—	—	
	C			$V_{DD} > 1.8\text{ V}$ $I_{Load} = -1\text{ mA}$	$V_{DD} - 0.5$	—	—	
4	D	Output high current Max total I_{OH} for all ports	I_{OHT}		—	—	100	mA
5	C	Output low voltage All non-LCD pins low-drive strength	V_{OL}	$V_{DD} > 1.8\text{ V}$ $I_{Load} = 0.6\text{ mA}$	—	—	0.5	V
	P	All non-LCD pins high-drive strength		$V_{DD} > 2.7\text{ V}$ $I_{Load} = 10\text{ mA}$	—	—	0.5	
	C			$V_{DD} > 1.8\text{ V}$ $I_{Load} = 3\text{ mA}$	—	—	0.5	
6	C	Output low voltage All LCD/GPIO pins low-drive strength	V_{OL}	$V_{DD} > 1.8\text{ V}$ $I_{Load} = 0.5\text{ mA}$	—	—	0.5	V
	P	All LCD/GPIO pins high-drive strength		$V_{DD} > 2.7\text{ V}$ $I_{Load} = 3\text{ mA}$	—	—	0.5	
	C			$V_{DD} > 1.8\text{ V}$ $I_{Load} = 1\text{ mA}$	—	—	0.5	
7	D	Output low current Max total I_{OL} for all ports	I_{OLT}		—	—	100	mA

Electrical Characteristics

Table 8. DC Characteristics (continued)

Num	C	Characteristic	Symbol	Condition	Min	Typ ¹	Max	Unit
8	P	Input high voltage all digital inputs	V_{IH}	$V_{DD} > 2.7\text{ V}$	$0.70 \times V_{DD}$	—	—	V
	C				$V_{DD} > 1.8\text{ V}$	$0.85 \times V_{DD}$	—	
9	P	Input low voltage all digital inputs	V_{IL}	$V_{DD} > 2.7\text{ V}$	—	—	$0.35 \times V_{DD}$	
	C				$V_{DD} > 1.8\text{ V}$	—	—	
10	C	Input hysteresis all digital inputs	V_{hys}		$0.06 \times V_{DD}$	—	—	mV
11	P	Input leakage current all input only pins (per pin)	$ I_{in} $	$V_{in} = V_{DD} \text{ or } V_{SS}$	—	0.025	1	μA
12	P	Hi-Z (off-state) leakage current all input/output (per pin)	$ I_{OZ} $	$V_{in} = V_{DD} \text{ or } V_{SS}$	—	0.025	1	μA
13	P	Total leakage current ² Total leakage current for all pins	$ I_{inT} $	$V_{in} = V_{DD} \text{ or } V_{SS}$	—	—	2	μA
14	P	Pullup, Pulldown resistors all digital inputs, when enabled	R_{PU}, R_{PD}		17.5	—	52.5	$k\Omega$
15	P	Pullup, Pulldown resistors all digital inputs, when enabled	R_{PU}, R_{PD}		17.5	—	52.5	$k\Omega$
16	D	DC injection current ^{3, 4, 5} Single pin limit Total MCU limit, includes sum of all stressed pins	I_{IC}	$V_{in} < V_{SS}, V_{in} > V_{DD}$	-0.2	—	0.2	mA
					-5	—	5	mA
17	C	Input Capacitance, all pins	C_{in}		—	—	8	pF
18	C	RAM retention voltage	V_{RAM}		—	0.6	1.0	V
19	C	iRTC RAM retention voltage	V_{iRTC}		—	1.05	—	V
20	C	POR re-arm voltage ⁶	V_{POR}		0.9	1.4	2.0	V
21	D	POR re-arm time	t_{POR}		10	—	—	μs
22	C	Low-voltage detection threshold	V_{LVDH}	High range — V_{DD} falling	2.11	2.16	2.22	V
					High range — V_{DD} rising	2.16	2.23	
23	C	Low-voltage detection threshold	V_{LVDL}	Low range — V_{DD} falling	1.80	1.85	1.91	V
				Low range — V_{DD} rising	1.86	1.92	1.99	
24	C	Low-voltage warning threshold	V_{LVWH}	V_{DD} falling, LVWV = 1	2.36	2.46	2.56	V
				V_{DD} rising, LVWV = 1	2.52	2.49	2.71	
25	C	Low-voltage warning	V_{LVWL}	V_{DD} falling, LVWV = 0	2.10	2.16	2.23	V
				V_{DD} rising, LVWV = 0	2.15	2.23	2.26	
26	C	Low-voltage inhibit reset/recover hysteresis	V_{hys}		—	80	—	mV
27	P	Bandgap Voltage Reference ⁷	V_{BG}		1.15	1.17	1.18	V

¹ Typical values are measured at 25°C. Characterized, not tested

- 2 Total leakage current is the sum value for all GPIO pins. This leakage current is not distributed evenly across all pins but characterization data shows that individual pin leakage current maximums are less than 250nA.
- 3 All functional non-supply pins, except for PTB2 are internally clamped to V_{SS} and V_{DD} .
- 4 Input must be current limited to the value specified. To determine the value of the required current-limiting resistor, calculate resistance values for positive and negative clamp voltages, then use the larger of the two values.
- 5 Power supply must maintain regulation within operating V_{DD} range during instantaneous and operating maximum current conditions. If the positive injection current ($V_{In} > V_{DD}$) is greater than I_{DD} , the injection current may flow out of V_{DD} and could result in external power supply going out of regulation. Ensure that external V_{DD} load will shunt current greater than maximum injection current. This will be the greatest risk when the MCU is not consuming power. Examples are: if no system clock is present, or if clock rate is very low (which would reduce overall power consumption).
- 6 POR will occur below the minimum voltage.
- 7 Factory trimmed at $V_{DD} = 3.0\text{ V}$, $\text{Temp} = 25^\circ\text{C}$

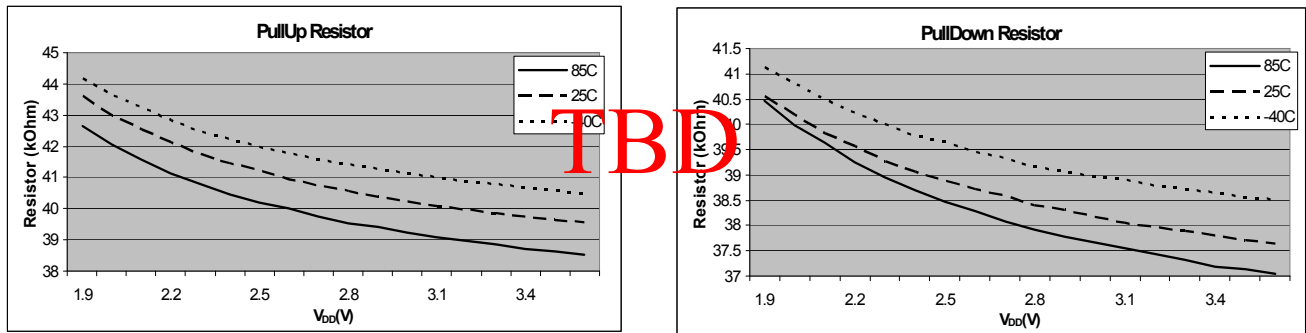

Figure 4. Non LCD pins I/O Pullup and Pulldown Typical Resistor Values ($V_{DD} = 3.0\text{ V}$)

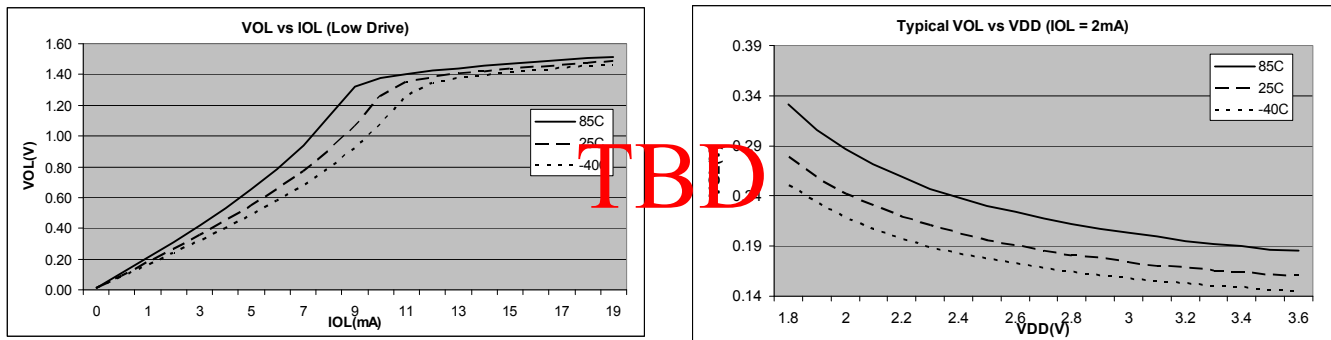

Figure 5. Typical Low-Side Driver (Sink) Characteristics(Non LCD pins) — Low Drive ($PTxDSn = 0$)

Electrical Characteristics

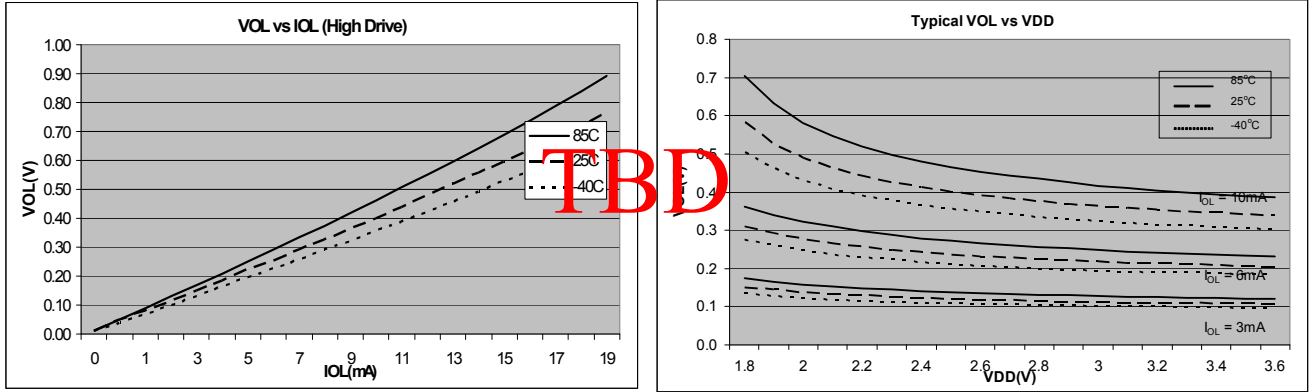

Figure 6. Typical Low-Side Driver (Sink) Characteristics(Non LCD pins) — High Drive (PTxDSn = 1)

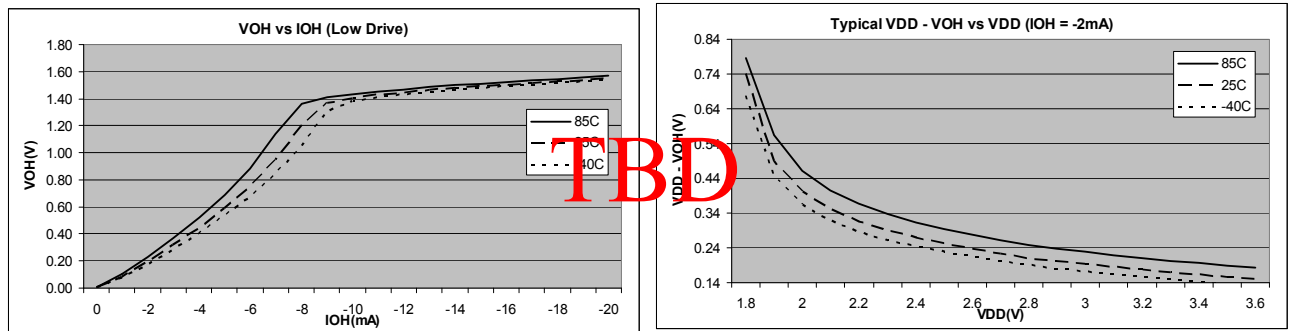

Figure 7. Typical High-Side (Source) Characteristics (Non LCD pins)— Low Drive (PTxDSn = 0)

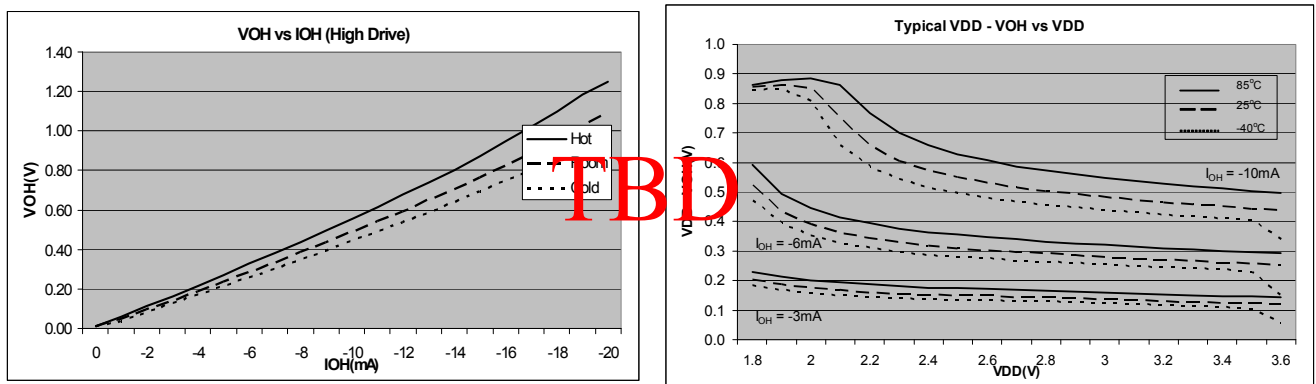

Figure 8. Typical High-Side (Source) Characteristics(Non LCD pins) — High Drive (PTxDSn = 1)

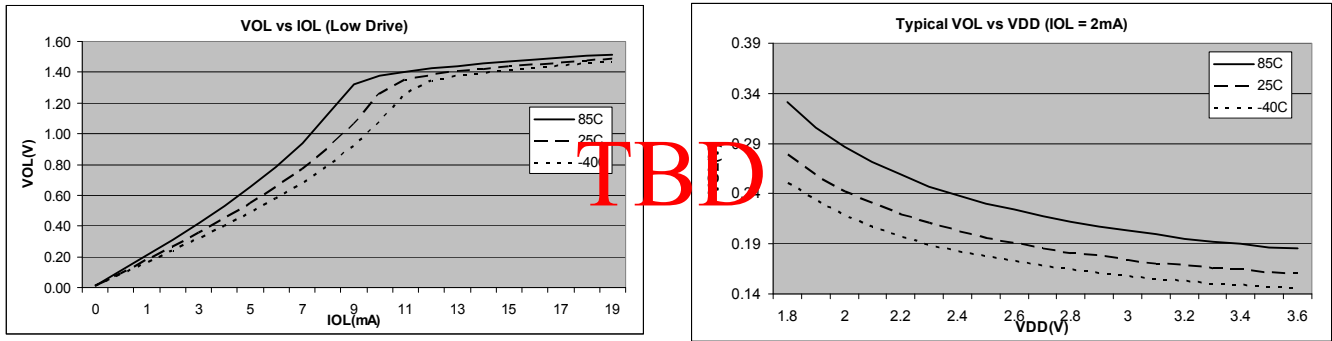

Figure 9. Typical Low-Side Driver (Sink) Characteristics(LCD/GPIO pins) — Low Drive (PTxDSn = 0)

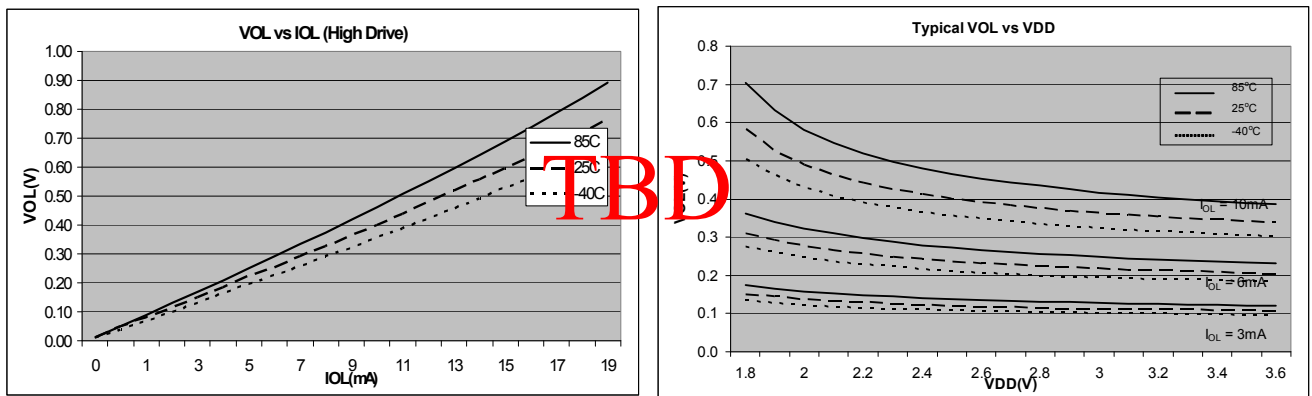

Figure 10. Typical Low-Side Driver (Sink) Characteristics(LCD/GPIO pins) — High Drive (PTxDSn = 1)

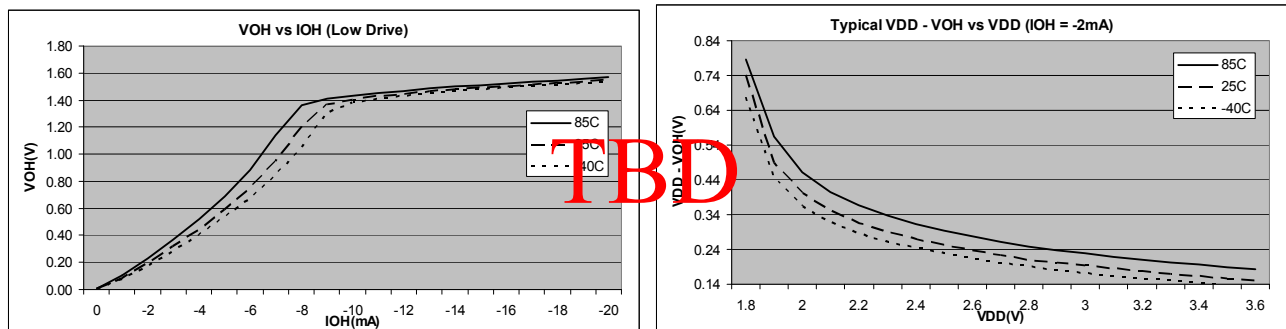

Figure 11. Typical High-Side (Source) Characteristics (LCD/GPIO pins)— Low Drive (PTxDSn = 0)

Electrical Characteristics

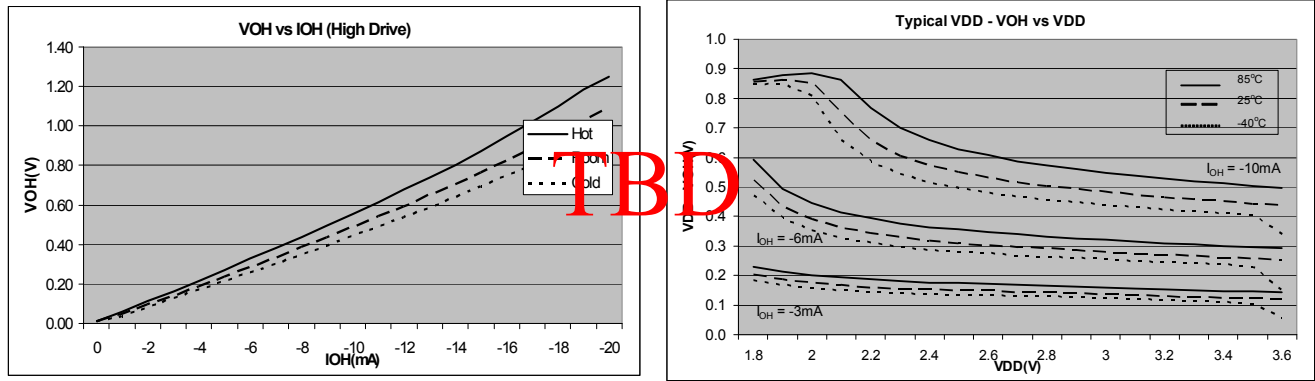

Figure 12. Typical High-Side (Source) Characteristics(LCD/GPIO pins) — High Drive (PTxDSn = 1)

3.7 Supply Current Characteristics

This section includes information about power supply current in various operating modes.

Table 9. Supply Current Characteristics

Num	C	Parameter	Symbol	Bus Freq	V _{DD} (V)	Typ ¹	Max	Unit	Temp (°C)
1	C	Run supply current FEI mode, all modules on, running from Flash	R _I DD	20 MHz	3	17.4	TBD	mA	-40 to 85°C
	T			2 MHz		2.6	TBD		
2	C	Run supply current FEI mode, all modules off, running from Flash	R _I DD	20 MHz	3	10.5	—	mA	-40 to 85°C
	T			2 MHz		1.6	—		
3	T	Run supply current LPRS=0, all modules off, running from Flash	R _I DD	16 kHz FBILP	3	158	—	μA	-40 to 85°C
	T			16 kHz FBELP		148	—		
4	T	Run supply current LPRS=1, all modules off; running from Flash	R _I DD	16 kHz FBILP	3	160	—	μA	-40 to 85°C
	T			16 kHz FBELP		23	—		
5	T	Run supply current LPRS=1, all modules off; running from RAM	R _I DD	16 kHz FBILP	3	137	—	μA	-40 to 85°C
	T			16 kHz FBELP		8	—		
6	C	Wait mode supply current, all modules off	W _I DD	20 MHz	3	5.4	TBD	mA	-40 to 85°C
	C			2 MHz		1.1	TBD		
7	T	Wait mode supply current LPRS = 0, all modules off	W _I DD	16 kHz FBILP	3	131	—	μA	-40 to 85°C
	T			16 kHz FBELP		123	—		

Table 9. Supply Current Characteristics

Num	C	Parameter	Symbol	Bus Freq	V _{DD} (V)	Typ ¹	Max	Unit	Temp (°C)
8	T	Wait mode supply current LPRS = 1, all modules off	W _I DD	16 kHz FBILP	3	159	—	μA	-40 to 85°C
	T			16 kHz FBELP	3	5.6	—	μA	-40 to 85°C
9	C	Stop2 mode supply current	S ₂ I _{DD}	N/A	3	300	TBD	nA	-40 to 25°C
						TBD	—		50°C
						TBD	TBD		70°C
						TBD	—		85°C
	C			N/A	2	TBD	—	-40 to 25°C	
						TBD	—	70°C	
TBD	—	85°C							
10	P	Stop3 mode supply current No clocks active	S ₃ I _{DD}	N/A	3	474	TBD	nA	-40 to 25°C
						TBD	—		50°C
						TBD	TBD		70°C
						TBD	—		85°C
	C			N/A	2	TBD	—	-40 to 25°C	
						TBD	—	70°C	
TBD	—	85°C							

¹ Typical values are measured at 25°C. Characterized, not tested.

Table 10. Stop Mode Adders

Num	C	Parameter	Condition	Temperature (°C)				Units
				-40	25	70	85	
1	T	LPO		TBD	TBD	TBD	TBD	nA
2	T	ERREFSTEN	RANGE = HGO = 0	TBD	TBD	TBD	TBD	nA
3	T	IREFSTEN ¹		TBD	TBD	TBD	TBD	μA
4	T	LVD ¹	LVDSE = 1	TBD	TBD	TBD	TBD	μA
5	T	PRACMP ¹	Not using the bandgap (BGBE = 0)	TBD	TBD	TBD	TBD	μA
6	T	VREFO	Not using the bandgap (BGBE = 0)	TBD	TBD	TBD	TBD	μA
7	T	IRTC	Not using the bandgap (BGBE = 0)	TBD	TBD	TBD	TBD	μA

Table 10. Stop Mode Adders (continued)

Num	C	Parameter	Condition	Temperature (°C)				Units
				-40	25	70	85	
8	T	ADC ¹	ADLPC = ADLSMP = 1 Not using the bandgap (BGBE = 0)	TBD	TBD	TBD	TBD	μA
9	T	LCD	VIREG enabled for Contrast control, 1/8 Duty cycle, 8x24 configuration for driving 192 Segments, 32Hz frame rate, No LCD glass connected.	TBD	TBD	TBD	TBD	μA
10	T	PCNT ¹	32KHz clock, without PWM output	TBD	TBD	TBD	TBD	μA
11	T	PCNT ¹	32KHz clock, with PWM output	TBD	TBD	TBD	TBD	μA

¹ Not available in stop2 mode.

3.8 External Oscillator (XOSCVLP) Characteristics

Reference [Figure 13](#) and [Figure 14](#) for crystal or resonator circuits.

Table 11. XOSCVLP and ICS Specifications (Temperature Range = -40 to 85°C Ambient)

Num	C	Characteristic	Symbol	Min	Typ ¹	Max	Unit
1	C	Oscillator crystal or resonator (EREFS = 1, ERCLKEN = 1) Low range (RANGE = 0) High range (RANGE = 1), high gain (HGO = 1) High range (RANGE = 1), low power (HGO = 0)	f_{lo} f_{hi} f_{hi}	32 1 1	— — —	38.4 16 8	kHz MHz MHz
2	D	Load capacitors Low range (RANGE=0), low power (HGO=0) Other oscillator settings	C_1, C_2	See Note ² See Note ³			
3	D	Feedback resistor Low range, low power (RANGE=0, HGO=0) ² Low range, high gain (RANGE=0, HGO=1) High range (RANGE=1, HGO=X)	R_F	— — —	— 10 1	— — —	MΩ
4	D	Series resistor — Low range, low power (RANGE = 0, HGO = 0) ² Low range, high gain (RANGE = 0, HGO = 1) High range, low power (RANGE = 1, HGO = 0) High range, high gain (RANGE = 1, HGO = 1) ≥ 8 MHz 4 MHz 1 MHz	R_S	— — — — — —	— 100 0 0 0 0	— — — 0 10 20	kΩ
5	C	Crystal start-up time ⁴ Low range, low power Low range, high gain High range, low power High range, high gain	t_{CSTL} t_{CSTH}	— — — —	600 400 5 15	— — — —	ms

Table 11. XOSCVLP and ICS Specifications (Temperature Range = -40 to 85°C Ambient)

Num	C	Characteristic	Symbol	Min	Typ ¹	Max	Unit
6	D	Square wave input clock frequency (EREFS = 0, ERCLKEN = 1) FEE mode FBE or FBELP mode	f_{extal}	0.03125 0	— —	20 20	MHz MHz

¹ Data in Typical column was characterized at 3.0 V, 25°C or is typical recommended value.

² Load capacitors (C_1, C_2), feedback resistor (R_F) and series resistor (R_S) are incorporated internally when RANGE=HGO=0.

³ See crystal or resonator manufacturer's recommendation.

⁴ Proper PC board layout procedures must be followed to achieve specifications.

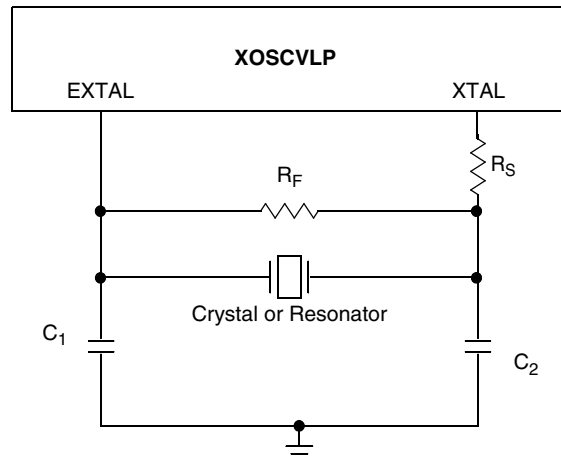

Figure 13. Typical Crystal or Resonator Circuit: High Range and Low Range/High Gain

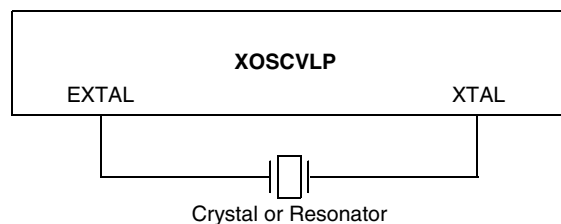

Figure 14. Typical Crystal or Resonator Circuit: Low Range/Low Power

3.9 Internal Clock Source (ICS) Characteristics

Table 12. ICS Frequency Specifications (Temperature Range = -40 to 85°C Ambient)

Num	C	Characteristic	Symbol	Min	Typ ¹	Max	Unit
1	P	Average internal reference frequency — factory trimmed at VDD = 3.6 V and temperature = 25 °C	$f_{\text{int_ft}}$	—	32.768	—	kHz
2	P	Average internal reference frequency - trimmed	$f_{\text{int_t}}$	31.25	—	39.063	kHz
3	T	Internal reference start-up time	t_{IRST}	—	—	6	μs

Table 12. ICS Frequency Specifications (Temperature Range = -40 to 85°C Ambient) (continued)

Num	C	Characteristic	Symbol	Min	Typ ¹	Max	Unit
4	P	DCO output frequency range - untrimmed	f_{dco_ut}	12.8	16.8	21.33	MHz
5	P	DCO output frequency range - trimmed	f_{dco_t}	16	—	20	MHz
6	C	Resolution of trimmed DCO output frequency at fixed voltage and temperature (using FTRIM)	$\Delta f_{dco_res_t}$	—	± 0.1	± 0.2	% f_{dco}
7	C	Resolution of trimmed DCO output frequency at fixed voltage and temperature (not using FTRIM)	$\Delta f_{dco_res_t}$	—	± 0.2	± 0.4	% f_{dco}
8	C	Total deviation from trimmed DCO output frequency over voltage and temperature	Δf_{dco_t}	—	+ 0.5 -1.0	± 2	% f_{dco}
9	C	Total deviation from trimmed DCO output frequency over fixed voltage and temperature range of 0°C to 70 °C	Δf_{dco_t}	—	± 0.5	± 1	% f_{dco}
10	C	FLL acquisition time ²	$t_{Acquire}$	—	—	1	ms
11	C	Long term jitter of DCO output clock (averaged over 2-ms interval) ³	C_{Jitter}	—	0.02	0.2	% f_{dco}

¹ Data in Typical column was characterized at 3.0 V, 25°C or is typical recommended value.

² This specification applies to any time the FLL reference source or reference divider is changed, trim value changed or changing from FLL disabled (FBELP, FBILP) to FLL enabled (FEI, FEE, FBE, FBI). If a crystal/resonator is being used as the reference, this specification assumes it is already running.

³ Jitter is the average deviation from the programmed frequency measured over the specified interval at maximum f_{Bus} . Measurements are made with the device powered by filtered supplies and clocked by a stable external clock signal. Noise injected into the FLL circuitry via V_{DD} and V_{SS} and variation in the crystal oscillator frequency increase the C_{Jitter} percentage for a given interval.

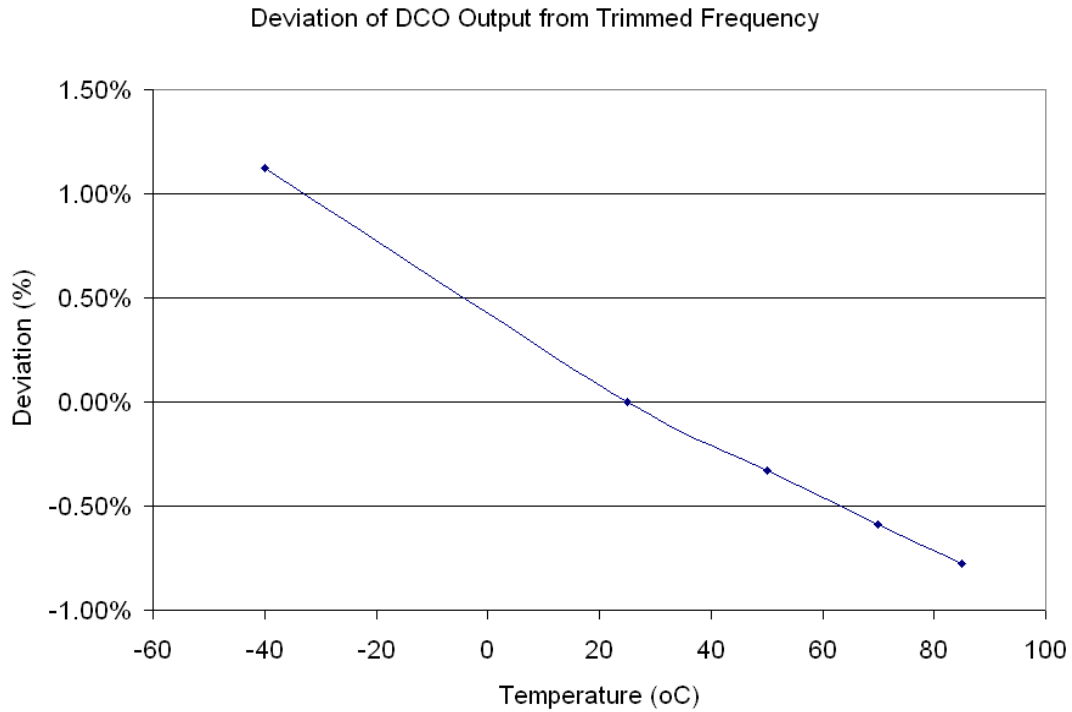

Figure 15. Deviation of DCO Output from Trimmed Frequency (20 MHz, 3.0 V)

3.10 AC Characteristics

This section describes timing characteristics for each peripheral system.

3.10.1 Control Timing

Table 13. Control Timing

Num	C	Rating	Symbol	Min	Typ ¹	Max	Unit
1	D	Bus frequency ($t_{cyc} = 1/f_{Bus}$)	f_{Bus}	dc	—	20	MHz
2	D	Internal low power oscillator period	t_{LPO}	700	—	1300	μs
3	D	External reset pulse width ²	t_{extrst}	100	—	—	ns
4	D	Reset low drive	t_{rstdrv}	$34 \times t_{cyc}$	—	—	ns
5	D	BKGD/MS setup time after issuing background debug force reset to enter user or BDM modes	t_{MSSU}	500	—	—	ns
6	D	BKGD/MS hold time after issuing background debug force reset to enter user or BDM modes ³	t_{MSH}	100	—	—	μs
7	D	IRQ pulse width Asynchronous path ² Synchronous path ⁴	t_{ILIH}, t_{IHIL}	100 $1.5 \times t_{cyc}$	— —	— —	ns
8	D	Keyboard interrupt pulse width Asynchronous path ² Synchronous path ⁴	t_{ILIH}, t_{IHIL}	100 $1.5 \times t_{cyc}$	— —	— —	ns
9	C	Port rise and fall time — Non-LCD Pins Low output drive (PTxDS = 0) (load = 50 pF) ^{5, 6} Slew rate control disabled (PTxSE = 0) Slew rate control enabled (PTxSE = 1)	t_{Rise}, t_{Fall}	— —	16 23	— —	ns
		Port rise and fall time — Non-LCD Pins High output drive (PTxDS = 1) (load = 50 pF) ^{5, 6} Slew rate control disabled (PTxSE = 0) Slew rate control enabled (PTxSE = 1)	t_{Rise}, t_{Fall}	— —	5 9	— —	ns
10	C	Voltage Regulator Recovery time	t_{VRR}	—	6	10	μs

- ¹ Typical values are based on characterization data at $V_{DD} = 3.0 V$, $25^{\circ}C$ unless otherwise stated.
- ² This is the shortest pulse that is guaranteed to be recognized as a reset pin request.
- ³ To enter BDM mode following a POR, BKGD/MS should be held low during the power-up and for a hold time of t_{MSH} after V_{DD} rises above V_{LVD} .
- ⁴ This is the minimum pulse width that is guaranteed to pass through the pin synchronization circuitry. Shorter pulses may or may not be recognized. In stop mode, the synchronizer is bypassed so shorter pulses can be recognized.
- ⁵ Timing is shown with respect to 20% V_{DD} and 80% V_{DD} levels. Temperature range $-40^{\circ}C$ to $85^{\circ}C$.
- ⁶ Except for LCD pins in Open Drain mode.

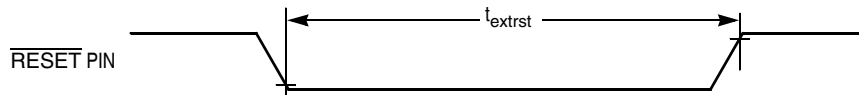

Figure 16. Reset Timing

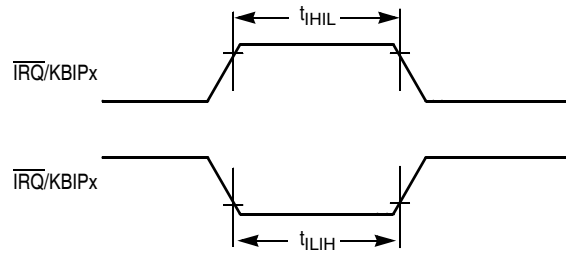

Figure 17. $\overline{\text{IRQ}}/\text{KBIPx}$ Timing

3.10.2 Timer (TPM/FTM) Module Timing

Synchronizer circuits determine the shortest input pulses that can be recognized or the fastest clock that can be used as the optional external source to the timer counter. These synchronizers operate from the current bus rate clock.

Table 14. TPM Input Timing

No.	C	Function	Symbol	Min	Max	Unit
1	D	External clock frequency	f_{TCLK}	0	$f_{\text{Bus}}/4$	Hz
2	D	External clock period	t_{TCLK}	4	—	t_{cyc}
3	D	External clock high time	t_{clkh}	1.5	—	t_{cyc}
4	D	External clock low time	t_{clkl}	1.5	—	t_{cyc}
5	D	Input capture pulse width	t_{ICPW}	1.5	—	t_{cyc}

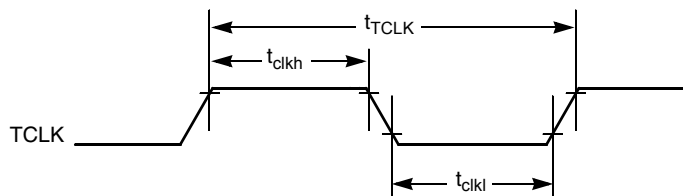
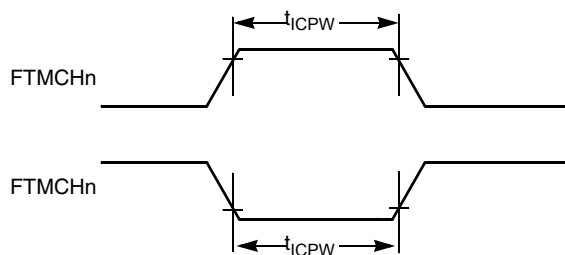

Figure 18. Timer External Clock



3.10.3 SPI Timing

Table 15 and Figure 19 through Figure 22 describe the timing requirements for the SPI system^{1,2}.

Table 15. SPI Timing

No.	C	Function	Symbol	Min	Max	Unit
—	D	Operating frequency Master Slave	f_{op}	$f_{Bus}/2048$ 0	$f_{Bus}/2$ $f_{Bus}/4$	Hz
①	D	SPSCK period Master Slave	t_{SPSCK}	2 4	2048 —	t_{cyc} t_{cyc}
②	D	Enable lead time Master Slave	t_{Lead}	1/2 1	— —	t_{SPSCK} t_{cyc}
③	D	Enable lag time Master Slave	t_{Lag}	1/2 1	— —	t_{SPSCK} t_{cyc}
④	D	Clock (SPSCK) high or low time Master Slave	t_{WSPSCK}	$t_{cyc} - 30$ $t_{cyc} - 30$	$1024 t_{cyc}$ —	ns ns
⑤	D	Data setup time (inputs) Master Slave	t_{SU}	30 30	— —	ns ns
⑥	D	Data hold time (inputs) Master Slave	t_{HI}	0 25	— —	ns ns
⑦	D	Slave access time	t_a	—	1	t_{cyc}
⑧	D	Slave MISO disable time	t_{dis}	—	1	t_{cyc}
⑨	D	Data valid (after SPSCK edge) Master Slave	t_v	— —	60 60	ns ns
⑩	D	Data hold time (outputs) Master Slave	t_{HO}	0 0	— —	ns ns
⑪	D	Rise time Input Output	t_{RI} t_{RO}	— —	$t_{cyc} - 25$ 25	ns ns
⑫	D	Fall time Input Output	t_{FI} t_{FO}	— —	$t_{cyc} - 25$ 25	ns ns

1. There is 20 pF load on the SPI ports.

2. There are three types of SPI ports in MC9S08GW64 Series. They are ports for AMR, ports shared with LCD pads and normal ports. This timing is for normal ports condition.

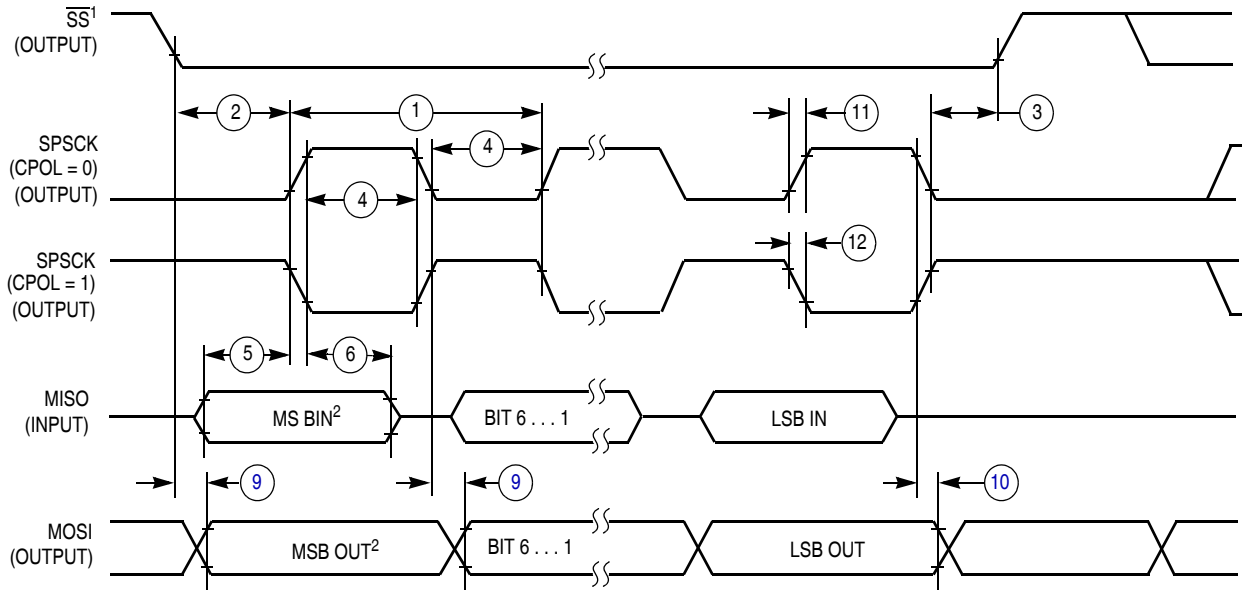

NOTES:

1. SS output mode (DDS7 = 1, SSOE = 1).
2. LSBF = 0. For LSBF = 1, bit order is LSB, bit 1, ..., bit 6, MSB.

Figure 19. SPI Master Timing (CPHA = 0)

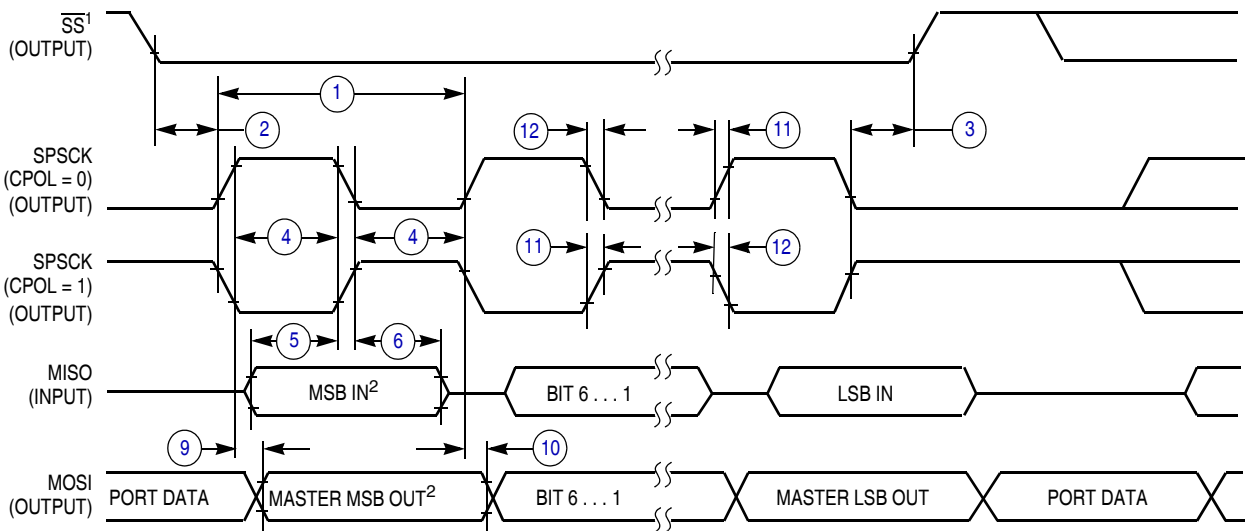

NOTES:

1. SS output mode (DDS7 = 1, SSOE = 1).
2. LSBF = 0. For LSBF = 1, bit order is LSB, bit 1, ..., bit 6, MSB.

Figure 20. SPI Master Timing (CPHA = 1)

Electrical Characteristics

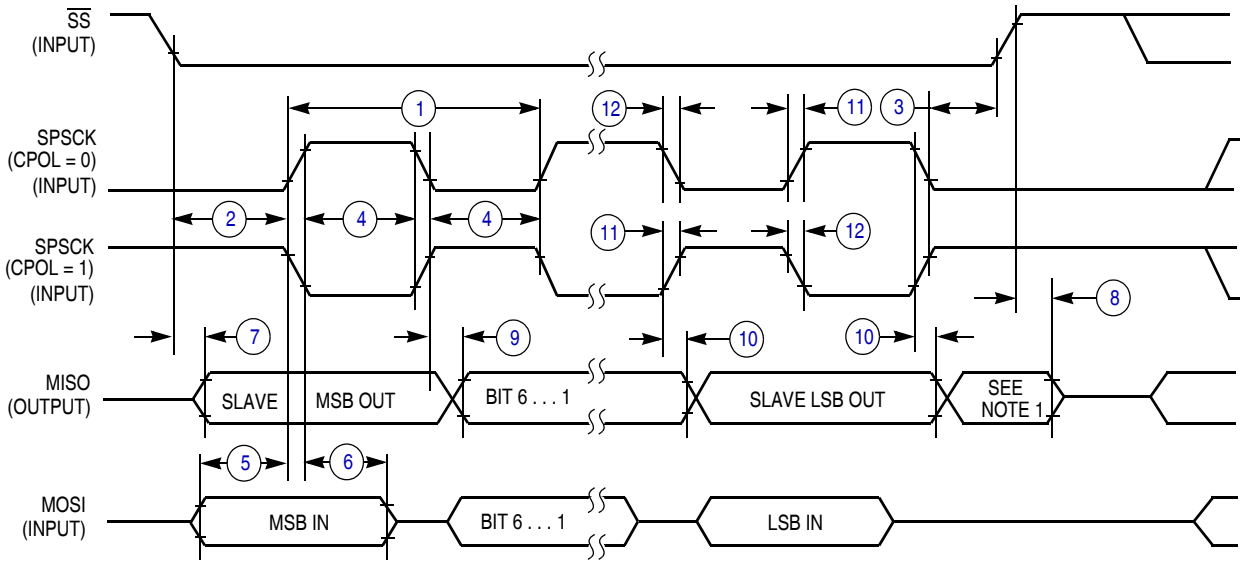

NOTE:

1. Not defined but normally MSB of character just received.

Figure 21. SPI Slave Timing (CPHA = 0)

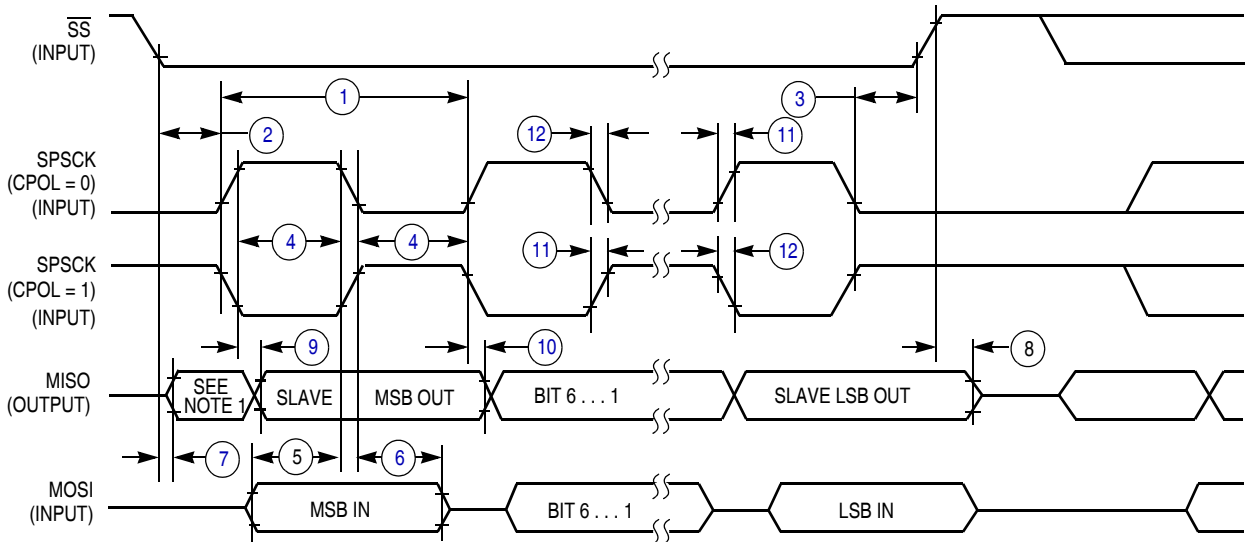

NOTE:

1. Not defined but normally LSB of character just received.

Figure 22. SPI Slave Timing (CPHA = 1)

3.11 Analog Comparator (PRACMP) Electricals

Table 16. PRACMP Electrical Specifications

N	C	Characteristic	Symbol	Min	Typical	Max	Unit
1	D	Supply voltage	V_{PWR}	1.8	—	3.6	V
2	C	Supply current (active) (PRG enabled)	I_{DDACT1}	—	—	60	μA
3	C	Supply current (active) (PRG disabled)	I_{DDACT2}	—	—	40	μA
4	C	Supply current (ACMP and PRG all disabled)	I_{DDDIS}	—	—	2	nA
5	D	Analog input voltage	V_{AIN}	$V_{SS} - 0.3$	—	V_{DD}	V
6	C	Analog input offset voltage	V_{AIO}	—	5	40	mV
7	C	Analog comparator hysteresis	V_H	3.0	—	20.0	mV
8	P	Analog input leakage current	I_{ALKG}	—	—	1	nA
9	C	Analog comparator initialization delay	t_{AINIT}	—	—	1.0	μs
10	C	Programmable reference generator inputs	$V_{In1}(V_{DD})$	1.8	—	V_{DD}	V
11	C	Programmable reference generator inputs	$V_{In2}(V_{DD25})$	1.8	—	2.75	V
12	C	Programmable reference generator setup delay	t_{PRGST}	TBD	TBD	TBD	ns
13	C	Programmable reference generator step size	V_{step}	-0.25	1	0.25	LSB
14	C	Programmable reference generator voltage range	V_{prgout}	$V_{In}/32$	—	V_{in}	V

3.12 ADC Characteristics

These specs all assume separate V_{DDAD} supply for ADC and isolated pad segment for ADC supplies and differential inputs.. Spec's should be de-rated for $V_{REFH} = V_{bg}$ condition.

Table 17. 16-bit ADC Operating Conditions

Num	Charact eristic	Conditions	Symb	Min	Typ ¹	Max	Unit	Comment
1	Supply voltage	Absolute	V_{DDA}	1.8	—	3.6	V	
2		Delta to V_{DD} ($V_{DD} - V_{DDA}$) ²	ΔV_{DDA}	-100	0	100	mV	
3	Ground voltage	Delta to V_{SS} ($V_{SS} - V_{SSA}$) ²	ΔV_{SSA}	-100	0	100	mV	
4	Ref Voltage High		V_{REFH}	1.15	V_{DDA}	V_{DDA}	V	

Table 17. 16-bit ADC Operating Conditions

Num	Characteristic	Conditions	Symb	Min	Typ ¹	Max	Unit	Comment
5	Ref Voltage Low		V_{REFL}	V_{SSA}	V_{SSA}	V_{SSA}	V	
6	Input Voltage		V_{ADIN}	V_{REFL}	—	V_{REFH}	V	
7	Input Capacitance	16-bit modes 8/10/12-bit modes	C_{ADIN}	—	8 4	10 5	pF	
8	Input Resistance		R_{ADIN}	—	2	5	k Ω	
9	Analog Source Resistance	16 bit modes $f_{ADCK} > 8\text{MHz}$ $4\text{MHz} < f_{ADCK} < 8\text{MHz}$ $f_{ADCK} < 4\text{MHz}$	R_{AS}	—	—	0.5 1 2	k Ω	External to MCU Assumes ADLSMP=0
10		13/12 bit modes $f_{ADCK} > 8\text{MHz}$ $4\text{MHz} < f_{ADCK} < 8\text{MHz}$ $f_{ADCK} < 4\text{MHz}$		—	—	1 2 5		
11		11/10 bit modes $f_{ADCK} > 8\text{MHz}$ $4\text{MHz} < f_{ADCK} < 8\text{MHz}$ $f_{ADCK} < 4\text{MHz}$		—	—	2 5 10		
12		9/8 bit modes $f_{ADCK} > 8\text{MHz}$ $f_{ADCK} < 8\text{MHz}$		—	—	5 10		
13	ADC Conversion Clock Freq.	ADLPC = 0, ADHSC = 1	f_{ADCK}	1.0	—	10	MHz	
14		ADLPC = 0, ADHSC = 0		1.0	—	5		
15		ADLPC = 1, ADHSC = 0		1.0	—	2.5		

¹ Typical values assume $V_{DDA} = 3.0\text{ V}$, $\text{Temp} = 25\text{ }^\circ\text{C}$, $f_{ADCK} = 1.0\text{ MHz}$ unless otherwise stated. Typical values are for reference only and are not tested in production.

² DC potential difference.

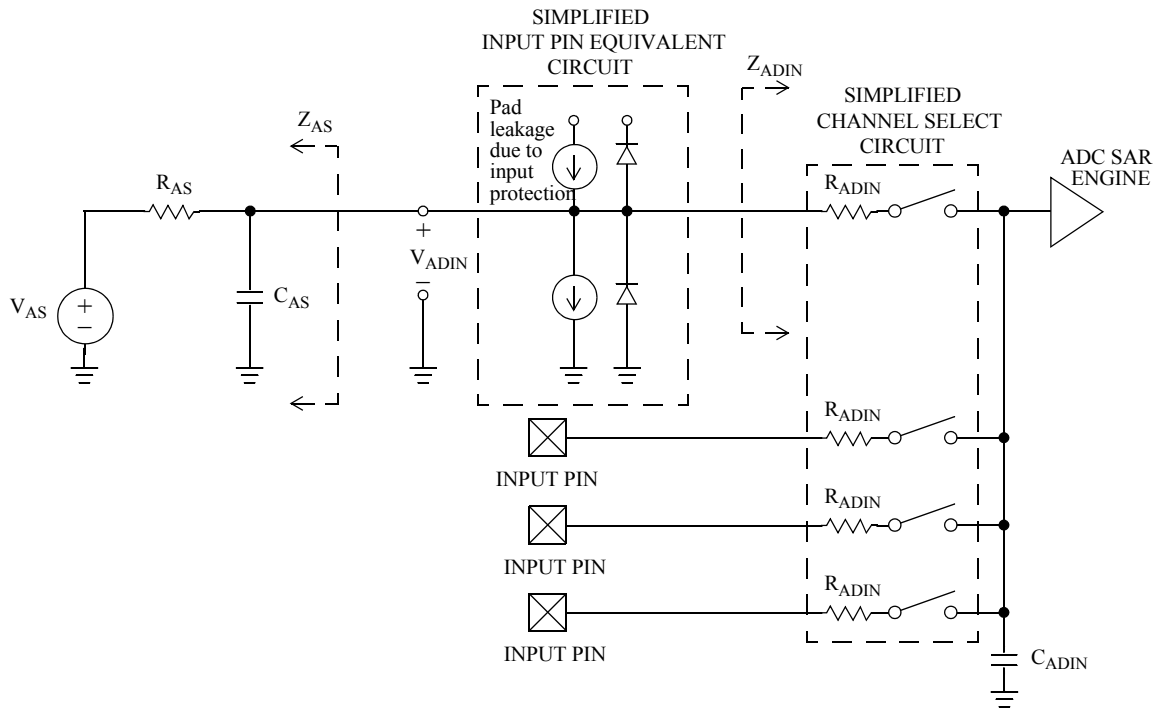

Figure 23. ADC Input Impedance Equivalency Diagram

Table 18. 16-bit ADC Characteristics full operating range ($V_{REFH} = V_{DDAD}$, $V_{REFL} = V_{SSAD}$, $F_{ADCK} \leq 10\text{MHz}$)

Characteristic	Conditions ¹	C	Symb	Min	Typ ²	Max	Unit	Comment
Supply Current	ADLPC = 1, ADHSC = 0	T	I_{DDA}	—	215	—	μA	ADLSMP = 0 ADCO = 1
	ADLPC = 0, ADHSC = 0			—	540	—		
	ADLPC=0, ADHSC=1			—	610	—		
Supply Current	Stop, Reset, Module Off	C	I_{DDA}	—	0.072	—	μA	
ADC Asynchronous Clock Source	ADLPC = 1, ADHSC = 0	P	f_{ADACK}	—	2.4	—	MHz	$t_{ADACK} = 1/f_{ADACK}$
	ADLPC = 0, ADHSC = 0			—	5.2	—		
	ADLPC = 0, ADHSC = 1			—	6.2	—		
Sample Time	See reference manual for sample times							
Conversion Time	See reference manual for conversion times							

¹ All accuracy numbers assume the ADC is calibrated with $V_{REFH} = V_{DDAD}$

² Typical values assume $V_{DDAD} = 3.0\text{V}$, $\text{Temp} = 25^\circ\text{C}$, $f_{ADCK} = 2.0\text{MHz}$ unless otherwise stated. Typical values are for reference only and are not tested in production.

Electrical Characteristics

Table 19. 16-bit ADC Characteristics ($V_{REFH} = V_{DDAD} \geq 2.7V$, $V_{REFL} = V_{SSAD}$, $F_{ADCK} \leq 4MHz$, $ADHSC=1$)

Characteristic	Conditions ¹	C	Symb	Min	Typ ²	Max	Unit	Comment
Total Unadjusted Error	16-bit differential mode 16-bit single-ended mode	T	TUE	— —	± 16 ± 20	$+24/-24$ $+32/-20$	LSB ³	32x Hardware Averaging (AVGE = %1 AVGS = %11)
	13-bit differential mode 12-bit single-ended mode	T		— —	± 1.5 ± 1.75	± 2.0 ± 2.5		
	11-bit differential mode 10-bit single-ended mode	T		— —	± 0.7 ± 0.8	± 1.0 ± 1.25		
	9-bit differential mode 8-bit single-ended mode	T		— —	± 0.5 ± 0.5	± 1.0 ± 1.0		
Differential Non-Linearity	16-bit differential mode 16-bit single-ended mode	T	DNL	— —	± 2.5 ± 2.5	± 3 ± 3	LSB ²	
	13-bit differential mode 12-bit single-ended mode	T		— —	± 0.7 ± 0.7	± 1 ± 1		
	11-bit differential mode 10-bit single-ended mode	T		— —	± 0.5 ± 0.5	± 0.75 ± 0.75		
	9-bit differential mode 8-bit single-ended mode	T		— —	± 0.2 ± 0.2	± 0.5 ± 0.5		
Integral Non-Linearity	16-bit differential mode 16-bit single-ended mode	T	INL	— —	± 6.0 ± 10.0	± 12.0 ± 16.0	LSB ²	
	13-bit differential mode 12-bit single-ended mode	T		— —	± 1.0 ± 1.0	± 2.0 ± 2.0		
	11-bit differential mode 10-bit single-ended mode	T		— —	± 0.5 ± 0.5	± 1.0 ± 1.0		
	9-bit differential mode 8-bit single-ended mode	T		— —	± 0.3 ± 0.3	± 0.5 ± 0.5		
Zero-Scale Error	16-bit differential mode 16-bit single-ended mode	T	E _{ZS}	— —	± 4.0 ± 4.0	$+16/0$ $+16/-38$	LSB ²	$V_{ADIN} = V_{SSAD}$
	13-bit differential mode 12-bit single-ended mode	T		— —	± 0.7 ± 0.7	± 2.0 ± 2.0		
	11-bit differential mode 10-bit single-ended mode	T		— —	± 0.4 ± 0.4	± 1.0 ± 1.0		
	9-bit differential mode 8-bit single-ended mode	T		— —	± 0.2 ± 0.2	± 0.5 ± 0.5		

Table 19. 16-bit ADC Characteristics ($V_{REFH} = V_{DDAD} \geq 2.7V$, $V_{REFL} = V_{SSAD}$, $F_{ADCK} \leq 4MHz$, $ADHSC=1$)

Characteristic	Conditions ¹	C	Symb	Min	Typ ²	Max	Unit	Comment
Full-Scale Error	16-bit differential mode 16-bit single-ended mode	T	E_{FS}	— —	+8/0 +12/0	+24/0 +24/0	LSB ²	$V_{ADIN} = V_{DDAD}$
	13-bit differential mode 12-bit single-ended mode	T		— —	±0.7 ±0.7	±2.0 ±2.5		
	11-bit differential mode 10-bit single-ended mode	T		— —	±0.4 ±0.4	±1.0 ±1.0		
	9-bit differential mode 8-bit single-ended mode	T		— —	±0.2 ±0.2	±0.5 ±0.5		
Quantization Error	16 bit modes	D	E_Q	—	-1 to 0	—	LSB ²	
	≤13 bit modes			—	—	±0.5		
Effective Number of Bits	16 bit differential mode Avg = 32 Avg = 16 Avg = 8 Avg = 4 Avg = 1	C	ENOB	— — — — —	13.5 13.4 13.2 13 12.6	— — — — —	Bits	For ADC_DIV=1, ADC_CLK=10 MHz.
	16 bit single-ended mode Avg = 32 Avg = 16 Avg = 8 Avg = 4 Avg = 1			— — — — —	12.39 12.34 12.13 11.94 11.4	— — — — —		
Signal to Noise plus Distortion	See ENOB		SINAD	$SINAD = 6.02 \cdot ENOB + 1.76$			dB	
Total Harmonic Distortion	16-bit differential mode Avg = 32	C	THD	—	—	—	dB	
	16-bit single-ended mode Avg = 32	D		—	—	—		
Spurious Free Dynamic Range	16-bit differential mode Avg = 32	C	SFDR	91.0	96.5	—	dB	
	16-bit single-ended mode Avg = 32	D		—	—	—		
Input Leakage Error	all modes	D	E_{IL}	$I_{in} \cdot R_{AS}$			mV	I_{in} = leakage current (refer to DC characteristics)
Temp Sensor Slope	-40°C–25°C	D	m	—	1.646	—	mV/°C	
	25°C–125°C			—	1.769	—		
Temp Sensor Voltage	25°C	D	V_{TEMP25}	—	966	—	mV	

Electrical Characteristics

¹ All accuracy numbers assume the ADC is calibrated with $V_{REFH}=V_{DDAD}$

² Typical values assume $V_{DDAD} = 3.0\text{ V}$, $\text{Temp} = 25\text{ }^{\circ}\text{C}$, $f_{ADCK}=2.0\text{MHz}$ unless otherwise stated. Typical values are for reference only and are not tested in production.

³ $1\text{ LSB} = (V_{REFH}-V_{REFL})/2^N$

3.13 VREF Characteristics

Table 20. Electrical specifications

Num	C	Characteristic	Symbol	Min	Max	Unit
1	P	Supply voltage	V_{DD}	1.80	3.60	V
2	P	Operating temperature range	T_{op}	-40	85	C
3	C	Maximum Load			10	mA
Operation across Temperature						
4	P	Voltage output room temperature	Untrimmed	1.070–1.202		V
5	P	Voltage output room temperature	Factory trimmed ¹	1.1995–1.2005		V
6	P	-40 °C	Factory trimmed	1.194–1.198		V
7	P	0 °C	Factory trimmed	1.198–1.201		V
8	P	50 °C	Factory trimmed	1.198–1.201		V
9	P	85 °C	Factory trimmed	1.196–1.200		V
Load Bandwidth						
10	C	Load Regulation Mode = 10 at 1mA load	Mode = 10	20	100	$\mu\text{V}/\text{mA}$
11	C	Line Regulation (Power Supply Rejection)	DC	± 0.1 from room temp voltage		mV
			AC	-60		dB
Power Consumption						
12	C	Powered down Current (Stop Mode, $V_{REFEN} = 0$, $V_{RSTEN} = 0$)	I		100	μA
13	C	Bandgap only (Mode[1:0] 00)	I		75	μA
14	C	Low Power buffer (Mode[1:0] 01)	I		125	μA
15	C	Tight Regulation buffer (Mode[1:0] 10)	I		1.1	mA
16	C	Low Power and Tight Regulation (Mode[1:0] 11)	I		1.15	mA

¹ Factory trim is performed at the room temperature.

3.14 LCD Specifications

Table 21. LCD Electricals, 3-V Glass

C	Characteristic	Symbol	Min	Typ	Max	Unit	
D	LCD Frame Frequency	f_{Frame}	28	30	58	Hz	
D	LCD Charge Pump Capacitance	C_{LCD}		100	100	nF	
D	LCD Bypass Capacitance	C_{BYLCD}		100	100	nF	
D	LCD Glass Capacitance	C_{glass}		2000	8000	pF	
D	V_{IREG}	HRefSel = 0	V_{IREG}	.89	1.00	1.15	V
		HRefSel = 1		1.49	1.67	1.85 ¹	
D	V_{IREG} TRIM Resolution	Δ_{RTRIM}	1.5			% V_{IREG}	
D	V_{IREG} Ripple	HRefSel = 0				.1	V
		HRefSel = 1					.15

¹ V_{IREG} Max can not exceed $V_{\text{DD}} - 0.15$ V

3.15 FLASH Specifications

This section provides details about program/erase times and program-erase endurance for the FLASH memory.

Program and erase operations do not require any special power sources other than the normal V_{DD} supply. For more detailed information about program/erase operations, see the Memory section.

Table 22. FLASH Characteristics

C	Characteristic	Symbol	Min	Typical	Max	Unit
D	Supply voltage for program/erase -40°C to 85°C	$V_{\text{prog/erase}}$	1.8		3.6	V
D	Supply voltage for read operation	V_{Read}	1.8		3.6	V
D	Internal FCLK frequency ¹	f_{FCLK}	150		200	kHz
D	Internal FCLK period (1/FCLK)	t_{Fcyc}	5		6.67	μs
P	Byte program time (random location) ²	t_{prog}		9		t_{Fcyc}
P	Byte program time (burst mode) ²	t_{Burst}		4		t_{Fcyc}
P	Page erase time ²	t_{Page}		4000		t_{Fcyc}
P	Mass erase time ²	t_{Mass}		20,000		t_{Fcyc}
D	Byte program current ³	R_{IDDBP}	—	4	—	mA
D	Page erase current ³	R_{IDPE}	—	6	—	mA
C	Program/erase endurance ⁴ T_{L} to $T_{\text{H}} = -40^{\circ}\text{C}$ to $+85^{\circ}\text{C}$ $T = 25^{\circ}\text{C}$		10,000	— 100,000	— —	cycles
C	Data retention ⁵	$t_{\text{D_ret}}$	15	100	—	years

¹ The frequency of this clock is controlled by a software setting.

Ordering Information

- ² These values are hardware state machine controlled. User code does not need to count cycles. This information supplied for calculating approximate time to program and erase.
- ³ The program and erase currents are additional to the standard run I_{DD} . These values are measured at room temperatures with $V_{DD} = 3.0$ V, bus frequency = 4.0 MHz.
- ⁴ Typical endurance for FLASH was evaluated for this product family on the 9S12Dx64. For additional information on how Freescale defines typical endurance, please refer to Engineering Bulletin EB619, *Typical Endurance for Nonvolatile Memory*.
- ⁵ Typical data retention values are based on intrinsic capability of the technology measured at high temperature and de-rated to 25°C using the Arrhenius equation. For additional information on how Freescale defines typical data retention, please refer to Engineering Bulletin EB618, *Typical Data Retention for Nonvolatile Memory*.

4 Ordering Information

This section contains the ordering information and the device numbering system for the MC9S08GW64 Series.

4.1 Device Numbering System

Example of the device numbering system:

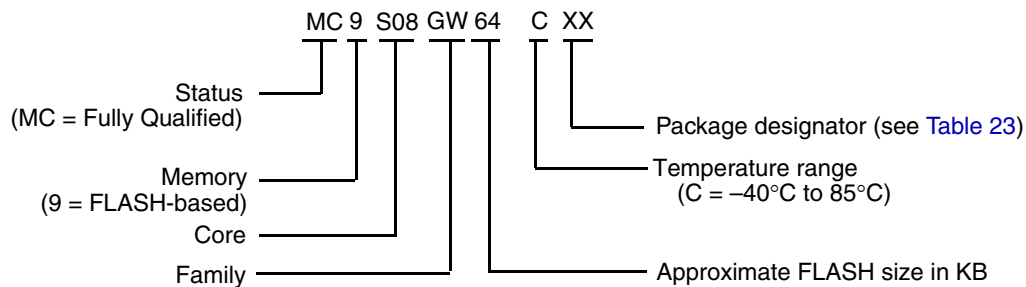

5 Package Information and Mechanical Drawings

Table 23 provides the available package types and their document numbers. The latest package outline/mechanical drawings are available on the MC9S08GW64 Series Product Summary pages at <http://www.freescale.com>.

To view the latest drawing, either:

- Click on the appropriate link in Table 23, or
- Open a browser to the Freescale® website (<http://www.freescale.com>), and enter the appropriate document number (from Table 23) in the “Enter Keyword” search box at the top of the page.

Table 23. Package Descriptions

Pin Count	Package Type	Abbreviation	Designator	Case No.	Document No.
80	Low Quad Flat Package	LQFP	LK	917A	98ASS23237W
64	Low Quad Flat Package	LQFP	LH	840F	98ASS23234W

How to Reach Us:

Home Page:

www.freescale.com

Web Support:

<http://www.freescale.com/support>

USA/Europe or Locations Not Listed:

Freescale Semiconductor, Inc.
Technical Information Center, EL516
2100 East Elliot Road
Tempe, Arizona 85284
+1-800-521-6274 or +1-480-768-2130
www.freescale.com/support

Europe, Middle East, and Africa:

Freescale Halbleiter Deutschland GmbH
Technical Information Center
Schatzbogen 7
81829 Muenchen, Germany
+44 1296 380 456 (English)
+46 8 52200080 (English)
+49 89 92103 559 (German)
+33 1 69 35 48 48 (French)
www.freescale.com/support

Japan:

Freescale Semiconductor Japan Ltd.
Headquarters
ARCO Tower 15F
1-8-1, Shimo-Meguro, Meguro-ku,
Tokyo 153-0064
Japan
0120 191014 or +81 3 5437 9125
support.japan@freescale.com

Asia/Pacific:

Freescale Semiconductor China Ltd.
Exchange Building 23F
No. 118 Jianguo Road
Chaoyang District
Beijing 100022
China
+86 10 5879 8000
support.asia@freescale.com

For Literature Requests Only:

Freescale Semiconductor Literature Distribution Center
1-800-441-2447 or 303-675-2140
Fax: 303-675-2150
LDCForFreescaleSemiconductor@hibbertgroup.com

Information in this document is provided solely to enable system and software implementers to use Freescale Semiconductor products. There are no express or implied copyright licenses granted hereunder to design or fabricate any integrated circuits or integrated circuits based on the information in this document.

Freescale Semiconductor reserves the right to make changes without further notice to any products herein. Freescale Semiconductor makes no warranty, representation or guarantee regarding the suitability of its products for any particular purpose, nor does Freescale Semiconductor assume any liability arising out of the application or use of any product or circuit, and specifically disclaims any and all liability, including without limitation consequential or incidental damages. "Typical" parameters that may be provided in Freescale Semiconductor data sheets and/or specifications can and do vary in different applications and actual performance may vary over time. All operating parameters, including "Typicals", must be validated for each customer application by customer's technical experts. Freescale Semiconductor does not convey any license under its patent rights nor the rights of others. Freescale Semiconductor products are not designed, intended, or authorized for use as components in systems intended for surgical implant into the body, or other applications intended to support or sustain life, or for any other application in which the failure of the Freescale Semiconductor product could create a situation where personal injury or death may occur. Should Buyer purchase or use Freescale Semiconductor products for any such unintended or unauthorized application, Buyer shall indemnify and hold Freescale Semiconductor and its officers, employees, subsidiaries, affiliates, and distributors harmless against all claims, costs, damages, and expenses, and reasonable attorney fees arising out of, directly or indirectly, any claim of personal injury or death associated with such unintended or unauthorized use, even if such claim alleges that Freescale Semiconductor was negligent regarding the design or manufacture of the part.

RoHS-compliant and/or Pb-free versions of Freescale products have the functionality and electrical characteristics as their non-RoHS-compliant and/or non-Pb-free counterparts. For further information, see <http://www.freescale.com> or contact your Freescale sales representative.

For information on Freescale's Environmental Products program, go to <http://www.freescale.com/epp>.

Freescale™ and the Freescale logo are trademarks of Freescale Semiconductor, Inc. All other product or service names are the property of their respective owners. ARM is the registered trademark of ARM Limited. ARM7TDMI-S is the trademark of ARM Limited.

The Power Architecture and Power.org word marks and the Power and Power.org logos and related marks are trademarks and service marks licensed by Power.org
© Freescale Semiconductor, Inc. 2010. All rights reserved.

Document Number: MC9S08GW64

Rev. 1
5/2010



PRELIMINARY-SUBJECT TO CHANGE WITHOUT NOTICE