



STR73xF

ARM7TDMI™ 32-BIT MCU WITH FLASH, 3x CAN, 4 UARTs, 20 TIMERS, ADC, 12 COMM. INTERFACES

DATA BRIEF

- **Core**
 - ARM7TDMI 32-bit RISC CPU
 - 32 MIPS @ 36 MHz
- **Temperature Range**
 - Operating temperature range -40 to 105 °C
- **Memories**
 - Up to 256 Kbytes FLASH program memory (10,000 cycles endurance, data retention 20 years at 55°C)
 - 16 Kbytes RAM
- **Clock, Reset and Supply Management**
 - 4.5 - 5.5V application supply and I/O interface
 - Embedded 1.8V regulator for core supply
 - Embedded oscillator running from external 4-8MHz crystal or ceramic resonator
 - Up to 36 MHz CPU freq. with internal PLL
 - Internal RC oscillator 32kHz or 2MHz software configurable for fast startup and backup clock
 - Realtime Clock for clock-calendar function
 - Wakeup Timer driven by internal RC for wake-up from STOP mode
 - 5 power saving modes: SLOW, WAIT, LPWAIT, STOP and HALT modes
- **Nested interrupt controller**
 - Fast interrupt handling with multiple vectors
 - 64 maskable IRQ with 64 vectors and 16 priority levels
 - 2 maskable FIQ sources
 - 16 external interrupts and up to 32 wake up lines
- **Up to 112 I/O ports**
 - 72/112 multifunctional bidirectional I/O lines

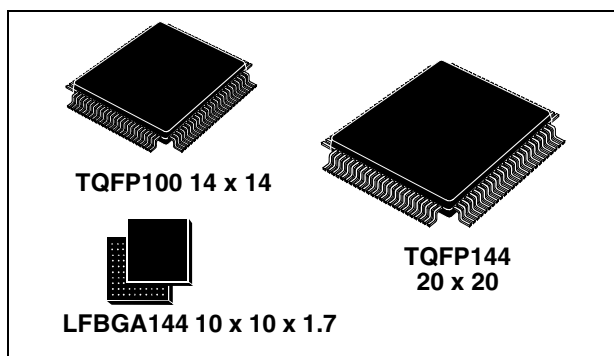

- **DMA**
 - 4 DMA controllers with 4 channels each
- **Timers**
 - 16-bit watchdog timer (WDG)
 - 6/10 16-bit timers (TIM) each with: 2 input captures, 2 output compares, PWM and pulse counter modes
 - 6 16-bit PWM modules (PWM)
 - 3 16-bit timebase timers with 8-bit prescalers
- **12 Communications Interfaces**
 - 2 I²C interfaces
 - 4 UART asynchronous serial communications interfaces
 - 3 BSPI synchronous serial interfaces
 - Up to 3 CAN interfaces (2.0B Active)
- **10-bit A/D Converter**
 - 12/16 channels
 - Conversion time: min 3µs, range: 0 to 5V
- **Development Tools Support**
 - JTAG interface

Table 1. Device Summary

Features	STR730FZx		STR735FZx		STR731FVx			STR736FVx		
FLASH memory - bytes	128K	256K	128K	256K	64K	128K	256K	64K	128K	256K
RAM - bytes	16K				16K					
Peripheral Functions	10 TIM Timers, 112 I/Os, 32 Wake-Up lines, 16 ADC channels				6 TIM Timers, 72 I/Os, 18 Wake-Up lines, 12 ADC channels					
CAN Peripherals	3		0		3			0		
Operating Voltage	4.5 to 5.5V (optional 1.8V for core)									
Operating Temperature	-40 to +105°C									
Packages	T=TQFP144 20 x 20 H=LFBGA144 10 x 10				T=TQFP100 14x14					

Rev. 1

1 INTRODUCTION

This Data Brief provides the STR73xF feature summary, pin description and ordering Information.

For complete information on the Mechanical and Electrical Device Characteristics please refer to the Preliminary Datasheet.

For complete information on the STR73xF Microcontroller memory, registers and peripherals, please refer to the STR73x Reference Manual.

For information on programming, erasing and protection of the internal Flash memory please refer to the STR7 Flash Programming Reference Manual

For information on the ARM7TDMI core please refer to the ARM7TDMI Technical Reference Manual.

1.1 Overview

ARM core with embedded Flash & RAM

STR73xF family combines the high performance ARM7TDMI™ CPU with an extensive range of peripheral functions and enhanced I/O capabilities. All devices have on-chip high-speed single voltage FLASH memory and high-speed RAM. The STR73xF family has an embedded ARM core and is therefore compatible with all ARM tools and software.

Extensive tools support

STMicroelectronics' 32-bit, ARM core-based microcontrollers are supported by a complete range of high-end and low-cost development tools to meet the needs of application developers. This extensive line of hardware/software tools includes starter kits and complete development packages all tailored for ST's ARM core-based MCUs. The range of development packages includes third-party solutions that come complete with a graphical development environment and an in-circuit emulator/programmer featuring a JTAG application interface. These support a range of embedded operating systems (OS), while several royalty-free OSs are also available.

For more information, please refer to ST MCU site <http://www.st.com/mcu>

Figure 1 shows the general block diagram of the device family.

Package Choice: Reduced Pin-Count TQFP100 or Feature-Rich 144-pin TQFP or LFBGA

The STR73xF family is available in 3 packages. The TQFP144 and LFBGA144 versions have the full set of all features. The 100-pin version has fewer timers, I/Os and ADC channels. Refer to the Device Summary on Page 1 for a comparison of the I/Os available on each package.

The family includes versions with and without CAN.

High Speed Flash Memory

The Flash program memory is organized in 32-bit wide memory cells which can be used for storing both code and data constants. It is accessed by CPU with zero wait states @ 36 MHz.

The STR7 embedded Flash memory can be programmed using In-Circuit Programming or In-Application programming.

The Flash memory endurance is 10K write/erase cycles and the data retention is 20 years at 55°C.

IAP (In-Application Programming): The IAP is the ability to re-program the Flash memory of a microcontroller while the user program is running.

ICP (In-Circuit Programming): The ICP is the ability to program the Flash memory of a microcontroller using JTAG protocol while the device is mounted on the user application board.

The Flash memory can be protected against different types of unwanted access (read/write/erase). There are two types of protection:

- Sector Write Protection
- Flash Debug Protection (locks JTAG access)

Flexible Power Management

To minimize power consumption, you can program the STR73xF to switch to SLOW, WAIT LPWAIT, STOP or HALT modes depending on the current system activity in the application.

Flexible Clock Control

Two clock sources are used to drive the microcontroller, a main clock driven by an external crystal or ceramic resonator and an internal backup RC oscillator that operates at 2MHz or 32 kHz. The embedded PLL allows the internal system clock (up to 36 MHz) to be generated from a main clock frequency of 10 MHz or less. The PLL output frequency can be programmed using a wide selection of multipliers and dividers.

Voltage Regulators

The STR73xF requires an external 4.5 to 5.5V power supply. There are two internal Voltage Regulators for generating the 1.8V power supply needed by the core and peripherals. The main VR is switched off and the Low Power VR switched on when the application puts the STR73xF in Low Power Wait (LPWAIT) mode.

Low Voltage Detectors

The voltage regulator and Flash modules each have an embedded LVD that monitors the internal 1.8V supply. If the voltage drops below a certain threshold, the LVD will reset the STR73xF.

Note: An external power-on reset must be provided ensure the microcontroller starts-up correctly.

On-Chip Peripherals

CAN Interfaces

The three CAN modules are compliant with the CAN specification V2.0 part B (active). The bit rate can be programmed up to 1 Mbaud. These are not available in the STR735 and STR736.

DMA

4 DMA controllers, each with 4 data streams manage memory to memory, peripheral to memory and memory to peripheral transfers. The DMA requests are connected to TIM timers, BSPI0, BSPI1, BSPI2 and ADC. One of the streams can be configured to be triggered by a software request, independently from any peripheral activity.

16-bit Timers (TIM)

Each of the ten timers (six in 100-pin devices) have a 16-bit free-running counter with 7-bit prescaler, up to two input capture/output compare functions, a pulse counter function, and a PWM channel with selectable frequency. This provides a total of 16 independent PWMs (12 in 100-pin devices) when added with the PWM modules (see next paragraph).

PWM Modules (PWM)

The six 16-bit PWM modules have independently programmable periods and duty-cycles, with 5+3 bit prescaler factor.

Timebase Timers (TB)

The three 16-bit Timebase Timers with 8-bit prescaler for general purpose time triggering operations.

Realtime Clock (RTC)

The RTC provides a set of continuously running counters driven by separate clock signal derived from the main oscillator. The RTC can be used as a general timebase or clock/calendar/alarm function. When the STR73xF is in LPWFI mode the RTC keeps running, powered by the low power voltage regulator.

UARTs

The 4 UARTs allow full duplex, asynchronous, communications with external devices with independently programmable TX and RX baud rates up to 625K baud.

Buffered Serial Peripheral Interfaces (BSPI)

Each of the three BSPIs allow full duplex, synchronous communications with external devices, master or slave communication at up to 6 Mb/s (@36 MHz System Clock).

I²C Interfaces

The two I²C Interfaces provide multi-master and slave functions, support normal and fast I²C mode (400 kHz) and 7 or 10-bit addressing modes.

A/D Converter

The 10-bit Analog to Digital Converter, converts up to 16 channels in single-shot or continuous conversion modes (12 channels in 100-pin devices). The minimum conversion time is 3 μ s.

Watchdog

The 16-bit Watchdog Timer protects the application against hardware or software failures and ensures recovery by generating a reset.

I/O Ports

Up to 112 I/O ports (72 in 100-pin devices) are programmable as general purpose input/output or Alternate Function.

External Interrupts and Wake-Up Lines

16 external interrupts lines are available for application use. In addition, up to 32 external Wakeup lines (18 in 100-pin devices) can be used as general purpose interrupts or to wake-up the application from STOP mode.

Figure 1. STR730F/STR735F Block Diagram

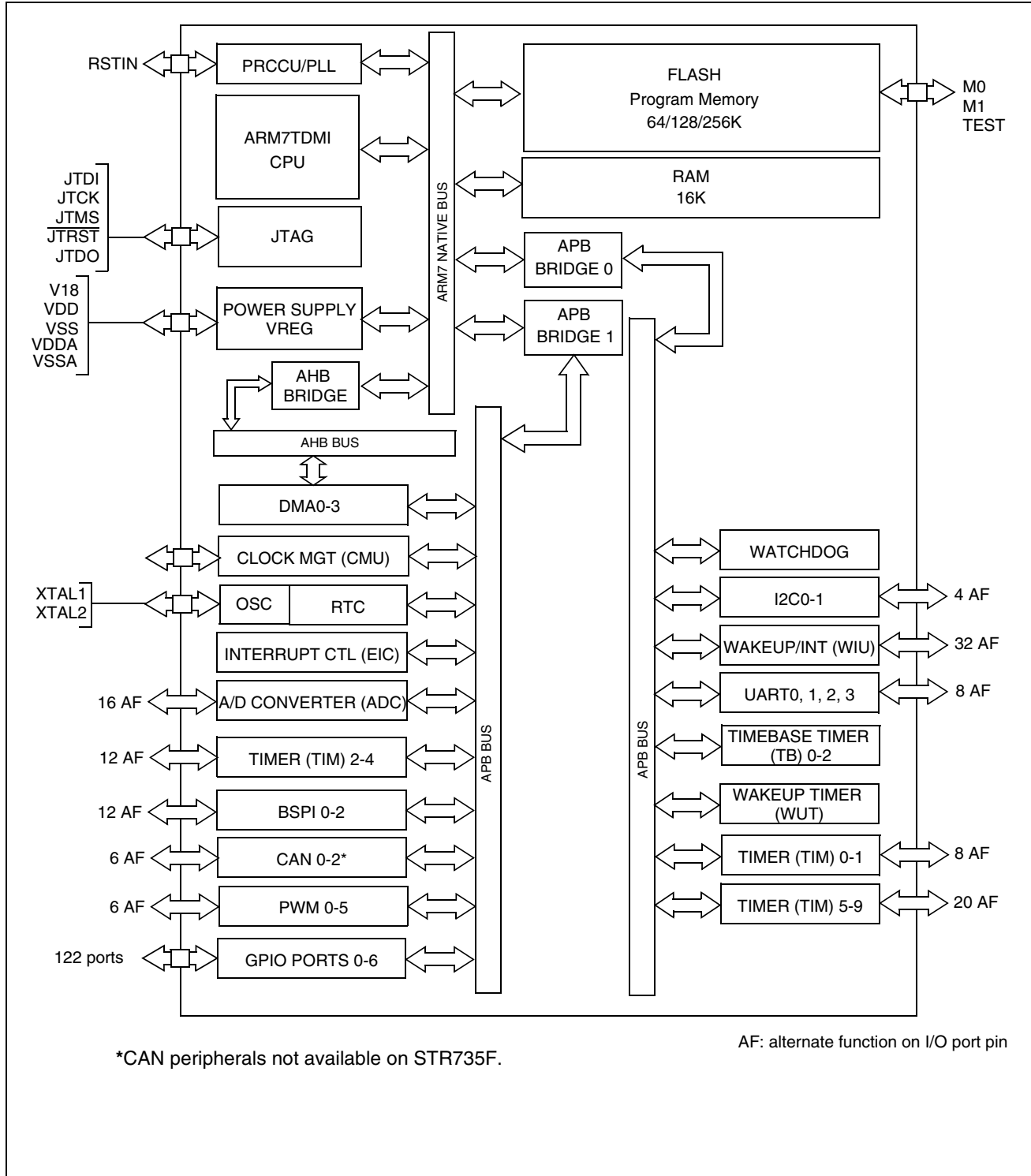
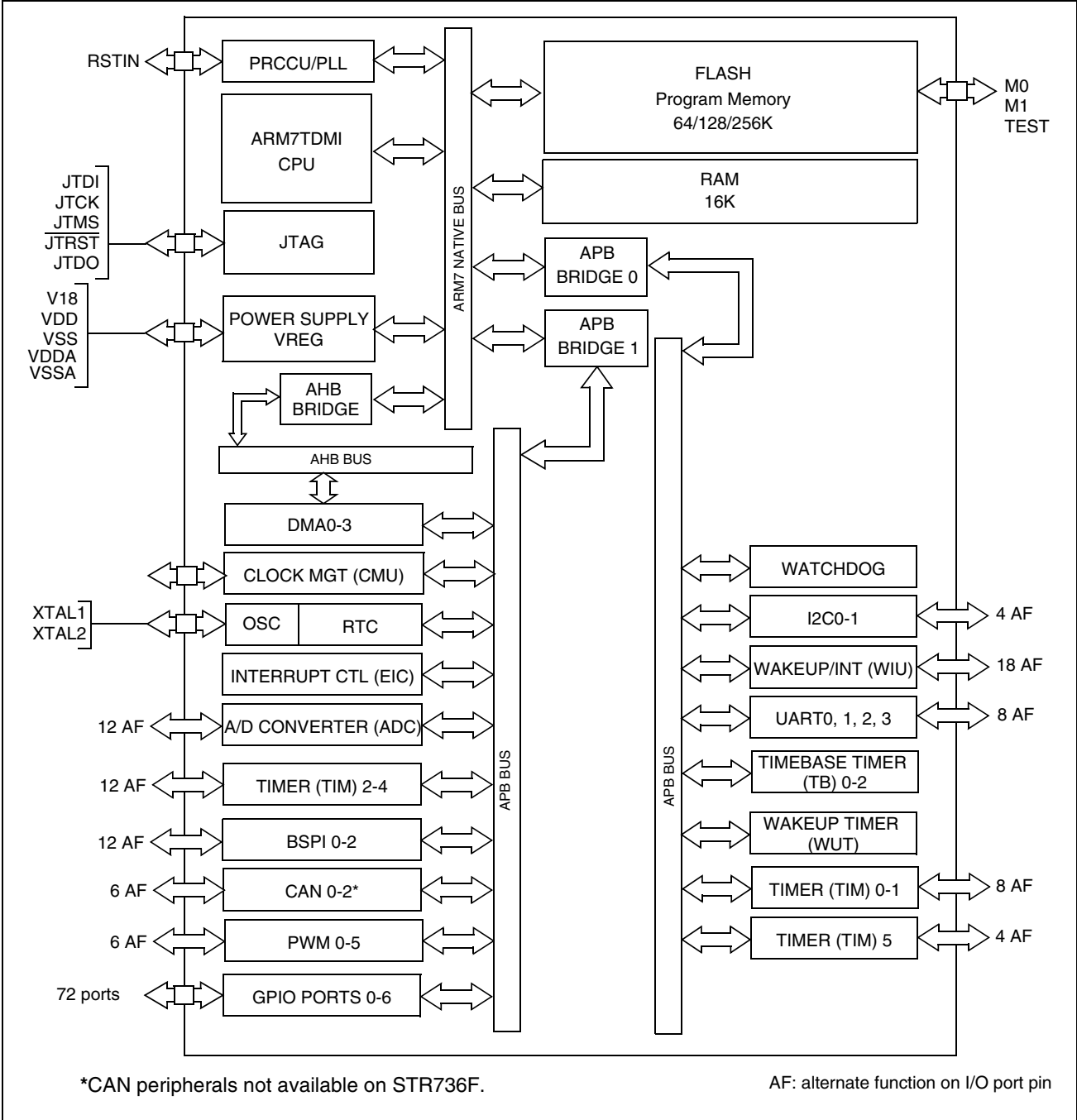

Figure 2. STR731F/STR736 Device Block Diagram



1.2 Related Documentation

Available from www.arm.com:

ARM7TDMI Technical Reference Manual

Available from <http://www.st.com>:

STR7 Flash Programming Reference Manual

STR73x Software Library User Manual

For a list of related application notes refer to <http://www.st.com>.

1.3 Pin Description

1.3.1 STR730F/STR735F (TQFP144)

Figure 3. STR730F/STR735F Pin Configuration (top view)

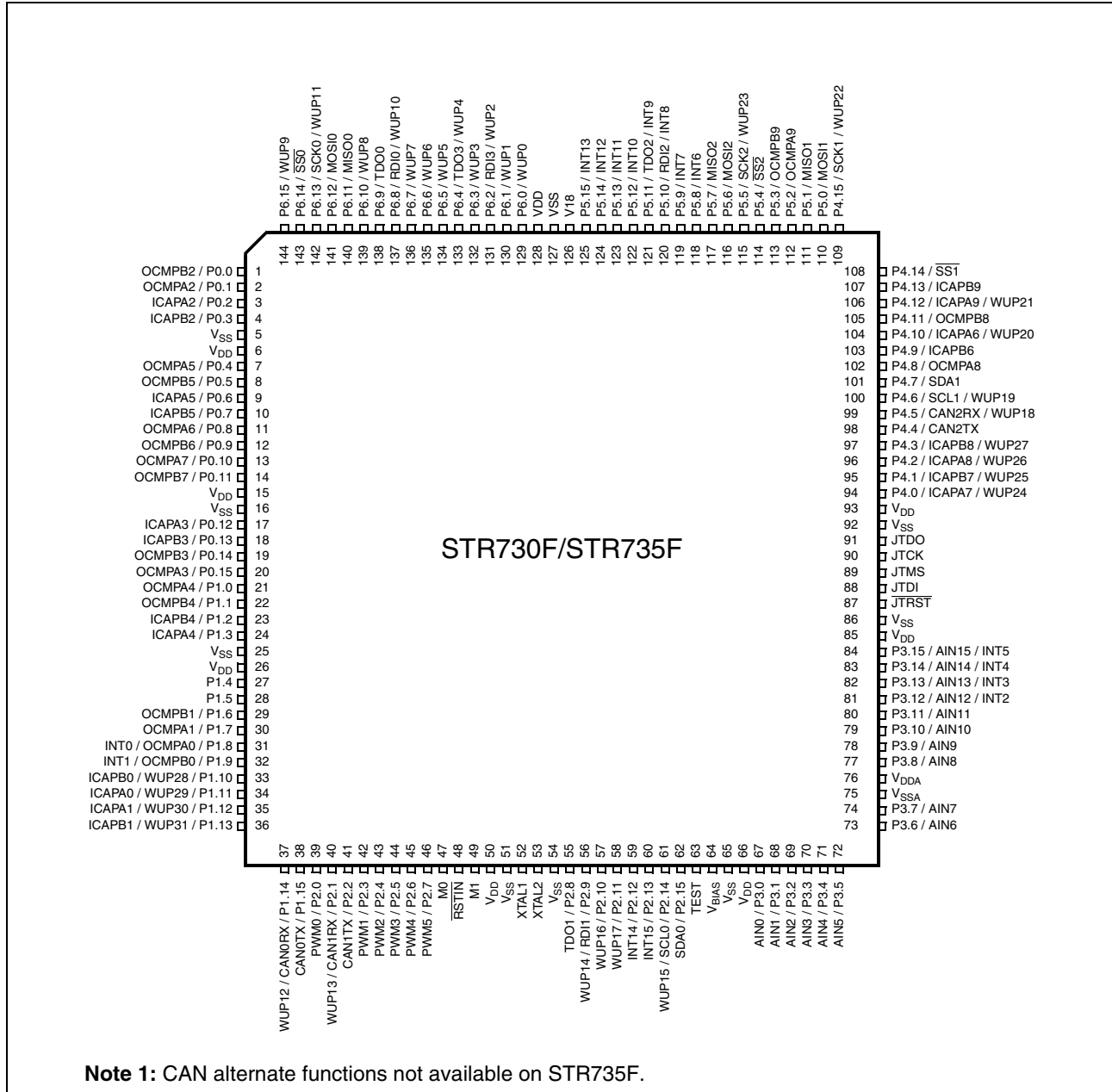

1.3.2 STR730F/STR735F (LFBGA144)

Table 2. STR730F/STR735F LFBGA Ball Connections

Ball	Name	Ball	Name	Ball	Name	Ball	Name
A1	P0.0 / OCMPB2	B1	P0.4 / OCMPA5	C1	P0.5 / OCMPB5	D1	V _{SS}
A2	P6.10 / WUP8	B2	P0.1 / OCMPA2	C2	P0.2 / ICAPA2	D2	V _{DD}
A3	P6.9 / TDO0	B3	P6.15 / WUP9	C3	P0.3 / ICAPB2	D3	P0.6 / ICAPA5
A4	P6.12 / MOSI0	B4	P6.13 / SCK0 / WUP11	C4	P6.14 / SSO	D4	P0.7 / ICAPB5
A5	P6.6 / WUP6	B5	P6.7 / WUP7	C5	P6.8 / RDI0 / WUP10	D5	P6.11 / MISO0
A6	V ₁₈	B6	P6.2 / WUP2 / RDI3	C6	P6.3 / WUP3	D6	P6.4 / WUP4 / TDO3
A7	P5.15 / INT13	B7	P5.14 / INT12	C7	V _{SS}	D7	V _{DD}
A8	P5.8 / INT6	B8	P5.9 / INT7	C8	P5.10 / INT8 / RDI2	D8	P5.12 / INT10
A9	P5.2 / OCMPA9	B9	P5.3 / OCMPB9	C9	P5.4 / SS2	D9	P5.5 / SCK2 / WUP23
A10	P5.7 / MISO2	B10	P5.0 / MOSI1	C10	P5.1 / MISO1	D10	P4.13 / ICAPB9
A11	P5.6 / MOSI2	B11	P4.15 / SCK1 / WUP22	C11	P4.14 / SS1	D11	P4.12 / ICAPA9 / WUP21
A12	P5.11 / TDO2 / INT9	B12	P4.8 / OCMPA8	C12	P4.7 / SDA1	D12	P4.11 / OCMPB8
E1	P0.8 / OCMPA6	F1	V _{DD}	G1	V _{SS}	H1	V _{DD}
E2	P0.9 / OCMPB6	F2	P0.13 / ICAPB3	G2	P1.2 / ICAPB4	H2	P1.8 / OCMPA0 / INT0
E3	P0.10 / OCMPA7	F3	P0.14 / OCMPB3	G3	P1.3 / ICAPA4	H3	P1.9 / OCMPB0 / INT1
E4	P0.11 / OCMPB7	F4	P0.15 / OCMPA3	G4	V _{SS}	H4	P1.10 / ICAPB0 / WUP28
E5	P0.12 / ICAPA3	F5	P1.0 / OCMPA4	G5	P1.5	H5	XTAL2
E6	P6.5 / WUP5	F6	P1.1 / OCMPB4	G6	P2.11 / WUP17	H6	P2.10 / WUP16
E7	P6.0 / WUP0	F7	P6.1 / WUP1	G7	P4.0 / ICAPA7 / WUP24	H7	P2.15 / SDA 0
E8	P5.13 / INT11	F8	P4.4 / CAN2TX ¹⁾	G8	V _{DD}	H8	JTMS
E9	P4.10 / ICAPA6 / WUP20	F9	P4.3 / ICAPB8 / WUP27	G9	V _{SS}	H9	V _{SS}

Table 2. STR730F/STR735F LFBGA Ball Connections

Ball	Name	Ball	Name	Ball	Name	Ball	Name
E10	P4.9 / ICAPB6	F10	P4.2 / ICAPA8 / WUP26	G10	JTDO	H10	VDD
E11	P4.6 / SCL1 / WUP19	F11	P4.1 / ICAPB7 / WUP25	G11	JTCK	H11	P3.15 / AIN15 / INT5
E12	P4.5 / WUP18 / CAN2RX ¹⁾	F12	JTDI	G12	nJTRST	H12	P3.14 / AIN14 / INT4
J1	P1.4	K1	P1.6 / OCMPB1	L1	P1.7 / OCMPA1	M1	P1.14 / CAN0RX ¹⁾ / WUP12
J2	P1.11 / ICAPA0 / WUP29	K2	P1.13 / ICAPB1 / WUP31	L2	P1.15 / CAN0TX ¹⁾	M2	P2.4 / PWM2
J3	P1.12 / ICAPA1 / WUP30	K3	P2.1 / CAN1RX ¹⁾ / WUP13	L3	P2.0 / PWM0	M3	P2.5 / PWM3
J4	P2.7 / PWM5	K4	P2.6 / PWM4	L4	P2.3 / PWM1	M4	P2.2 / CAN1TX ¹⁾
J5	V _{DD}	K5	M1	L5	RSTIN	M5	M0
J6	P2.9 / RDI1 / WUP14	K6	P2.8 / TDO1	L6	V _{SS}	M6	V _{SS}
J7	P2.14 / SCL0 / WUP15	K7	P2.13 / INT15	L7	P2.12 / INT14	M7	XTAL1
J8	P3.1 / AIN1	K8	P3.0 / AIN0	L8	VBIAS	M8	TST
J9	P3.13 / AIN13 / INT3	K9	P3.4 / AIN4	L9	P3.3 / AIN3	M9	P3.2 / AIN2
J10	P3.12 / AIN12 / INT2	K10	V _{DDA}	L10	P3.5 / AIN5	M10	V _{SS}
J11	P3.9 / AIN9	K11	V _{SSA}	L11	P3.7 / AIN7	M11	V _{DD}
J12	P3.8 / AIN8	K12	P3.11 / AIN11	L12	P3.10 / AIN10	M12	P3.6 / AIN6

Note 1: CAN alternate functions not available on STR735F.

1.3.3 STR731F/STR736F (TQFP100)

Figure 4. STR731F/STR736F Pin Configuration (top view)

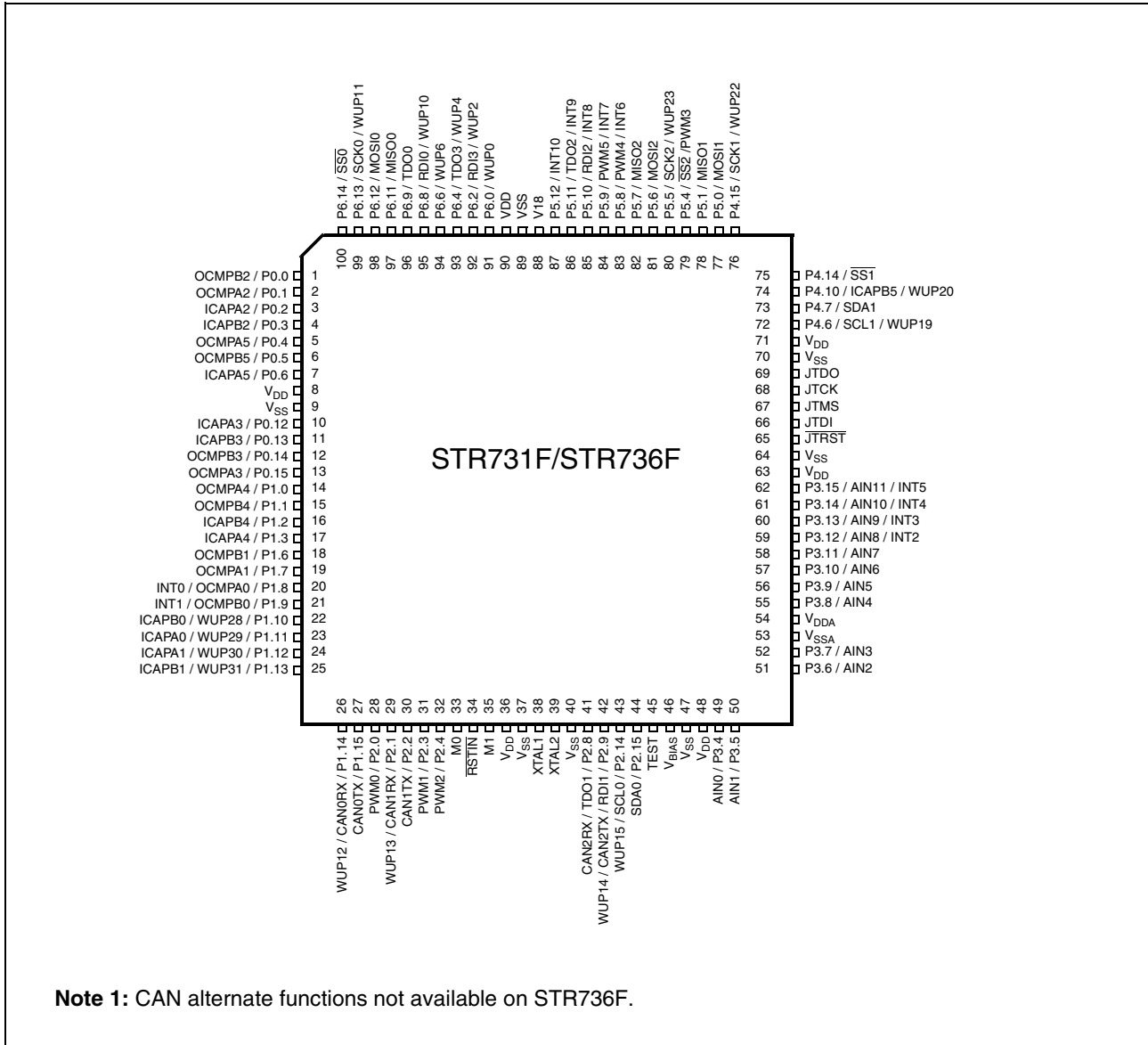

Note 1: CAN alternate functions not available on STR736F.

Legend / Abbreviations for Table 3:

Type: I = input, O = output, S = supply, HiZ= high impedance,

In/Output level: T_T = TTL 0.8V / 2V with input trigger

C_T = CMOS 0.3V_{DD}/0.7V_{DD} with input trigger

Port and control configuration:

- Input: pu/pd = with internal 100kΩ weak pull-up or pull down
- Output: OD = open drain (logic level)
PP = push-pull

Interrupts:

INTx =external interrupt line

WUPx =Wake-Up interrupt line

The reset state of the I/O ports is input floating. To avoid excess power consumption, unused I/O ports must be tied to ground.

Table 3. STR73xF Pin Description

Pin n°			Pin Name	Type	Input			Output			Main function (after reset)	Alternate function
TQFP144	LFPGA144	TQFP100			Input Level	pu/pd	interrupt	Capability	OD	PP		
1	A1	1	P0.0/OCMPB2	I/O	T_T			2mA	X	X	Port 0.0	TIM2: Output Compare B output
2	B2	2	P0.1/OCMPA2	I/O	T_T			2mA	X	X	Port 0.1	TIM2: Output Compare A output
3	C2	3	P0.2/ICAPA2	I/O	T_T			2mA	X	X	Port 0.2	TIM2: Input Capture A input
4	C3	4	P0.3/ICAPB2	I/O	T_T			2mA	X	X	Port 0.3	TIM2: Input Capture B input
5	D1		V _{SS}	S							Ground for digital I/O (5V)	
6	D2		V _{DD}	S							Supply voltage for digital I/O (5V)	
7	B1	5	P0.4/OCMPA5	I/O	T_T			2mA	X	X	Port 0.4	TIM5: Output Compare A output
8	C1	6	P0.5/OCMPB5	I/O	T_T			2mA	X	X	Port 0.5	TIM5: Output Compare B output
9	D3	7	P0.6/ICAPA5	I/O	T_T			2mA	X	X	Port 0.6	TIM5: Input Capture A input
10	D4		P0.7/ICAPB5	I/O	T_T			2mA	X	X	Port 0.7	TIM5: Input Capture B input
11	E1		P0.8/OCMPA6	I/O	T_T			2mA	X	X	Port 0.8	TIM6: Output Compare A output
12	E2		P0.9/OCMPB6	I/O	T_T			2mA	X	X	Port 0.9	TIM6: Output Compare B output
13	E3		P0.10/OCMPA7	I/O	T_T			2mA	X	X	Port 0.10	TIM7: Output Compare A output
14	E4		P0.11/OCMPB7	I/O	T_T			2mA	X	X	Port 0.11	TIM7: Output Compare B output
15	F1	8	V _{DD}	S							Supply voltage for digital I/O (5V)	
16	G1	9	V _{SS}	S							Ground for digital I/O (5V)	
17	E5	10	P0.12/ICAPA3	I/O	T_T			2mA	X	X	Port 0.12	TIM3: Input Capture A input
18	F2	11	P0.13/ICAPB3	I/O	T_T			2mA	X	X	Port 0.13	TIM3: Input Capture B input
19	F3	12	P0.14/OCMPB3	I/O	T_T			2mA	X	X	Port 0.14	TIM3: Output Compare B output

Table 3. STR73xF Pin Description

Pin n°			Pin Name	Type	Input			Output			Main function (after reset)	Alternate function
TQFP144	LFBGA144	TQFP100			Input Level	pu/pd	interrupt	Capability	OD	PP		
20	F4	13	P0.15/OCMPA3	I/O	T _T			2mA	X	X	Port 0.15	TIM3: Output Compare A output
21	F5	14	P1.0/OCMPA4	I/O	T _T			2mA	X	X	Port 1.0	TIM4: Output Compare A output
22	F6	15	P1.1/OCMPB4	I/O	T _T			2mA	X	X	Port 1.1	TIM4: Output Compare B output
23	G2	16	P1.2/ICAPB4	I/O	T _T			2mA	X	X	Port 1.2	TIM4: Input Capture B input
24	G3	17	P1.3/ICAPA4	I/O	T _T			2mA	X	X	Port 1.3	TIM4: Input Capture A input
25	G4		V _{SS}	S								Ground for digital I/O (5V)
26	H1		V _{DD}	S								Supply voltage for digital I/O (5V)
27	J1		P1.4	I/O	T _T			2mA	X	X	Port 1.4	
28	G5		P1.5	I/O	T _T			2mA	X	X	Port 1.5	
29	K1	18	P1.6/OCMPB1	I/O	T _T			2mA	X	X	Port 1.6	TIM1: Output Compare B output
30	L1	19	P1.7/OCMPA1	I/O	T _T			2mA	X	X	Port 1.7	TIM1: Output Compare A output
31	H2	20	P1.8/OCMPA0	I/O	T _T		INT0	2mA	X	X	Port 1.8	TIM0: Output Compare A output
32	H3	21	P1.9/OCMPB0	I/O	T _T		INT1	2mA	X	X	Port 1.9	TIM0: Output Compare B output
33	H4	22	P1.10/ICAPB0	I/O	T _T		WUP28	2mA	X	X	Port 1.10	TIM0: Input Capture B input
34	J2	23	P1.11/ICAPA0	I/O	T _T		WUP29	2mA	X	X	Port 1.11	TIM0: Input Capture A input
35	J3	24	P1.12/ICAPA1	I/O	T _T		WUP30	2mA	X	X	Port 1.12	TIM1: Input Capture A input
36	K2	25	P1.13/ICAPB1	I/O	T _T		WUP31	2mA	X	X	Port 1.13	TIM1: Input Capture B input
37	M1	26	P1.14/CAN0RX	I/O	T _T		WUP12	2mA	X	X	Port 1.14	CAN0: Receive Data input
38	L2	27	P1.15/CAN0TX	I/O	T _T			2mA	X	X	Port 1.15	CAN0: Transmit Data output
39	L3	28	P2.0/PWM0	I/O	T _T			2mA	X	X	Port 2.0	PWM0: PWM output
40	K3	29	P2.1/CAN1RX	I/O	T _T		WUP13	2mA	X	X	Port 2.1	CAN1: Receive Data input
41	M4	30	P2.2/CAN1TX	I/O	T _T			2mA	X	X	Port 2.2	CAN1: Transmit Data output
42	L4	31	P2.3/PWM1	I/O	T _T			2mA	X	X	Port 2.3	PWM1: PWM output
43	M2	32	P2.4/PWM2	I/O	T _T			2mA	X	X	Port 2.4	PWM2: PWM output
44	M3		P2.5/PWM3	I/O	T _T			2mA	X	X	Port 2.5	PWM3: PWM output
45	K4		P2.6/PWM4	I/O	T _T			2mA	X	X	Port 2.6	PWM4: PWM output
46	J4		P2.7/PWM5	I/O	T _T			2mA	X	X	Port 2.7	PWM5: PWM output
47	M5	33	M0	I	T _T	pd						BOOT: Mode selection 0 input
48	L5	34	$\overline{\text{RSTIN}}$	I	C _T	pu						Reset input
49	K5	35	M1	I	T _T	pd						BOOT: Mode selection 1 input
50	J5	36	V _{DD}	S								Supply voltage for digital I/O (5V)

Table 3. STR73xF Pin Description

Pin n°			Pin Name	Type	Input			Output			Main function (after reset)	Alternate function	
TQFP144	LFBGA144	TQFP100			Input Level	pu/pd	interrupt	Capability	OD	PP			
51	M6	37	V _{SS}	S							Ground for digital I/O (5V)		
52	M7	38	XTAL1	I							Oscillator amplifier circuit input and internal clock generator input.		
53	H5	39	XTAL2	O							Oscillator amplifier circuit output.		
54	L6	40	V _{SS}	S							Ground for digital I/O (5V)		
55	K6	41	P2.8/TDO1/ CAN2RX	I/O	T _T			2mA	X	X	Port 2.8	UART1: Transmit Data output	CAN2: Receive Data input (TQFP100 only)
56	J6	42	P2.9/RDI1/ CAN2TX	I/O	T _T		WUP14	2mA	X	X	Port 2.9	UART1: Receive Data input	CAN2: Transmit Data output (TQFP100 only)
57	H6		P2.10	I/O	T _T		WUP16	2mA	X	X	Port 2.10		
58	G6		P2.11	I/O	T _T		WUP17	2mA	X	X	Port 2.11		
59	L7		P2.12	I/O	T _T		INT14	2mA	X	X	Port 2.12		
60	K7		P2.13	I/O	T _T		INT15	2mA	X	X	Port 2.13		
61	J7	43	P2.14/SCL0	I/O	T _T		WUP15	2mA	X	X	Port 2.14	I2C0:Serial Clock	
62	H7	44	P2.15/SDA0	I/O	T _T			2mA	X	X	Port 2.15	I2C0:Serial Data	
63	M8	45	Test	I		pd					Reserved pin. Must be tied to ground		
64	L8	46	V _{BIAS}	S							Internal RC Oscillator bias. A 1.3MΩ external resistor has to be connected to this pin when a 32kHz RC oscillator frequency is used.		
65	M10	47	V _{SS}	S							Ground for digital I/O (5V)		
66	M11	48	V _{DD}	S							Supply voltage for digital I/O (5V)		
67	K8		P3.0/AIN0	I/O	T _T			2mA	X	X	Port 3.0	ADC: Analog input 0	
68	J8		P3.1/AIN1	I/O	T _T			2mA	X	X	Port 3.1	ADC: Analog input 1	
69	M9		P3.2/AIN2	I/O	T _T			2mA	X	X	Port 3.2	ADC: Analog input 2	
70	L9		P3.3/AIN3	I/O	T _T			2mA	X	X	Port 3.3	ADC: Analog input 3	
71	K9	49	P3.4/AIN4	I/O	T _T			2mA	X	X	Port 3.4	ADC: Analog input 4 (AIN0 in TQFP100)	
72	L10	50	P3.5/AIN5	I/O	T _T			2mA	X	X	Port 3.5	ADC: Analog input 5 (AIN1 in TQFP100)	
73	M12	51	P3.6/AIN6	I/O	T _T			2mA	X	X	Port 3.6	ADC: Analog input 6 (AIN2 in TQFP100)	
74	L11	52	P3.7/AIN7	I/O	T _T			2mA	X	X	Port 3.7	ADC: Analog input 7 (AIN3 in TQFP100)	

Table 3. STR73xF Pin Description

Pin n°			Pin Name	Type	Input			Output			Main function (after reset)	Alternate function
TQFP144	LFBGA144	TQFP100			Input Level	pu/pd	interrupt	Capability	OD	PP		
75	K11	53	V _{SSA}	S							Reference ground for A/D converter	
76	K10	54	V _{DDA}	S							Reference voltage for A/D converter	
77	J12	55	P3.8/AIN8	I/O	T _T			2mA	X	X	Port 3.8	ADC: Analog input 8 (AIN4 in TQFP100)
78	J11	56	P3.9/AIN9	I/O	T _T			2mA	X	X	Port 3.9	ADC: Analog input 9 (AIN5 in TQFP100)
79	L12	57	P3.10/AIN10	I/O	T _T			2mA	X	X	Port 3.10	ADC: Analog input 10 (AIN6 in TQFP100)
80	K12	58	P3.11/AIN11	I/O	T _T			2mA	X	X	Port 3.11	ADC: Analog input 11 (AIN7 in TQFP100)
81	J10	59	P3.12/AIN12	I/O	T _T		INT2	2mA	X	X	Port 3.12	ADC: Analog input 12 (AIN8 in TQFP100)
82	J9	60	P3.13/AIN13	I/O	T _T		INT3	2mA	X	X	Port 3.13	ADC: Analog input 13 (AIN9 in TQFP100)
83	H12	61	P3.14/AIN14	I/O	T _T		INT4	2mA	X	X	Port 3.14	ADC: Analog input 14 (AIN10 in TQFP100)
84	H11	62	P3.15/AIN15	I/O	T _T		INT5	2mA	X	X	Port 3.15	ADC: Analog input 15 (AIN11 in TQFP100)
85	H10	63	V _{DD}	S							Supply voltage for digital I/O (5V)	
86	H9	64	V _{SS}	S							Ground for digital I/O (5V)	
87	G12	65	JTRST	I	T _T							JTAG Reset Input
88	F12	66	JTDI	I	T _T	pu						JTAG Data input
89	H8	67	JTMS	I	T _T	pu						JTAG Mode Selection Input
90	G11	68	JTCK	I	T _T	pd						JTAG Clock Input
91	G10	69	JTDO	O				4mA				JTAG data output. Note: Reset state = HiZ
92	G9	70	V _{SS}	S								Ground for digital I/O (5V)
93	G8	71	V _{DD}	S								Supply voltage for digital I/O (5V)
94	G7		P4.0/ICAPA7	I/O	T _T		WUP24	2mA	X	X	Port 4.0	TIM7: Input Capture A input
95	F11		P4.1/ICAPB7	I/O	T _T		WUP25	2mA	X	X	Port 4.1	TIM7: Input Capture B input
96	F10		P4.2/ICAPA8	I/O	T _T		WUP26	2mA	X	X	Port 4.2	TIM8: Input Capture A input
97	F9		P4.3/ICAPB8	I/O	T _T		WUP27	2mA	X	X	Port 4.3	TIM8: Input Capture B input
98	F8		P4.4/CAN2TX	I/O	T _T			2mA	X	X	Port 4.4	CAN2: Transmit Data output
99	E12		P4.5/CAN2RX	I/O	T _T		WUP18	2mA	X	X	Port 4.5	CAN2: Receive Data input
100	E11	72	P4.6/SCL1	I/O	T _T		WUP19	2mA	X	X	Port 4.6	I2C1:Serial Clock
101	C12	73	P4.7/SDA1	I/O	T _T			2mA	X	X	Port 4.7	I2C1:Serial Data
102	B12		P4.8/OCMPA8	I/O	T _T			2mA	X	X	Port 4.8	TIM8: Output Compare A output
103	E10		P4.9/ICAPB6	I/O	T _T			2mA	X	X	Port 4.9	TIM6: Input Capture B input

Table 3. STR73xF Pin Description

Pin n°			Pin Name	Type	Input			Output			Main function (after reset)	Alternate function	
TQFP144	LFBGA144	TQFP100			Input Level	pu/pd	interrupt	Capability	OD	PP			
104	E9	74	P4.10/ICAPA6/ICAPB5	I/O	T _T		WUP20	2mA	X	X	Port 4.10	TIM6: Input Capture A input (144-pin pkg only)	TIM5: Input Capture B input (TQFP100 only)
105	D12		P4.11/OCMPB8	I/O	T _T			2mA	X	X	Port 4.11	TIM8: Output Compare B output	
106	D11		P4.12/ICAPA9	I/O	T _T		WUP21	2mA	X	X	Port 4.12	TIM9: Input Capture A input	
107	D10		P4.13/ICAPB9	I/O	T _T			2mA	X	X	Port 4.13	TIM9: Input Capture B input	
108	C11	75	P4.14/ \overline{SS} 1	I/O	T _T			2mA	X	X	Port 4.14	BSPI1: Slave Select	
109	B11	76	P4.15/SCK1	I/O	T _T		WUP22	2mA	X	X	Port 4.15	BSPI1: Serial Clock	
110	B10	77	P5.0/MOSI1	I/O	T _T			2mA	X	X	Port 5.0	BSPI1: Master Output/Slave input	
111	C10	78	P5.1/MISO1	I/O	T _T			2mA	X	X	Port 5.1	BSPI1: Master input/Slave output	
112	A9		P5.2/OCMPA9	I/O	T _T			2mA	X	X	Port 5.2	TIM9: Output Compare A output	
113	B9		P5.3/OCMPB9	I/O	T _T			2mA	X	X	Port 5.3	TIM9: Output Compare B output	
114	C9	79	P5.4/ \overline{SS} 2/PWM3	I/O	T _T			2mA	X	X	Port 5.4	BSPI2: Slave Select	PWM3: PWM output (TQFP100 only)
115	D9	80	P5.5/SCK2	I/O	T _T		WUP23	2mA	X	X	Port 5.5	BSPI2: Serial Clock	
116	A11	81	P5.6/MOSI2	I/O	T _T			2mA	X	X	Port 5.6	BSPI2: Master Output/Slave input	
117	A10	82	P5.7/MISO2	I/O	T _T			2mA	X	X	Port 5.7	BSPI2: Master input/Slave output	
118	A8	83	P5.8/PWM4	I/O	T _T		INT6	2mA	X	X	Port 5.8	PWM4: PWM output (TQFP100 only)	
119	B8	84	P5.9/PWM5	I/O	T _T		INT7	2mA	X	X	Port 5.9	PWM5: PWM output (TQFP100 only)	
120	C8	85	P5.10/RDI2	I/O	T _T		INT8	2mA	X	X	Port 5.10	UART2: Receive Data input	
121	A12	86	P5.11/TDO2	I/O	T _T		INT9	2mA	X	X	Port 5.11	UART2: Transmit Data output	
122	D8	87	P5.12	I/O	T _T		INT10	2mA	X	X	Port 5.12		
123	E8		P5.13	I/O	T _T		INT11	2mA	X	X	Port 5.13		
124	B7		P5.14	I/O	T _T		INT12	2mA	X	X	Port 5.14		
125	A7		P5.15	I/O	T _T		INT13	2mA	X	X	Port 5.15		
126	A6	88	V ₁₈	S								Supply voltage for core provided by internal voltage regulator	
127	C7	89	V _{SS}	S								Ground for digital I/O (5V)	
128	D7	90	V _{DD}	S								Supply voltage for digital I/O (5V)	

Table 3. STR73xF Pin Description

Pin n°			Pin Name	Type	Input			Output			Main function (after reset)	Alternate function
TQFP144	LFBGA144	TQFP100			Input Level	pu/pd	interrupt	Capability	OD	PP		
129	E7	91	P6.0	I/O	T _T		WUP0	8mA	X	X	Port 6.0	
130	F7		P6.1	I/O	T _T		WUP1	2mA	X	X	Port 6.1	
131	B6	92	P6.2/RDI3	I/O	T _T		WUP2	2mA	X	X	Port 6.2	UART3: Receive Data input
132	C6		P6.3	I/O	T _T		WUP3	2mA	X	X	Port 6.3	
133	D6	93	P6.4/TDO3	I/O	T _T		WUP4	2mA	X	X	Port 6.4	UART3: Transmit Data output
134	E6		P6.5	I/O	T _T		WUP5	2mA	X	X	Port 6.5	
135	A5	94	P6.6	I/O	T _T		WUP6	2mA	X	X	Port 6.6	
136	B5		P6.7	I/O	T _T		WUP7	2mA	X	X	Port 6.7	
137	C5	95	P6.8/RDI0	I/O	T _T		WUP10	2mA	X	X	Port 6.8	UART0: Receive Data input
138	A3	96	P6.9/TDO0	I/O	T _T			2mA	X	X	Port 6.9	UART0: Transmit Data output
139	A2		P6.10	I/O	T _T		WUP8	2mA	X	X	Port 6.10	
140	D5	97	P6.11/MISO0	I/O	T _T			2mA	X	X	Port 6.11	BSPI0: Master input/Slave output
141	A4	98	P6.12/MOSI0	I/O	T _T			2mA	X	X	Port 6.12	BSPI0: Master Output/Slave input
142	B4	99	P6.13/SCK0	I/O	T _T		WUP11	2mA	X	X	Port 6.13	BSPI0: Serial Clock
143	C4	100	P6.14/SS0	I/O	T _T			2mA	X	X	Port 6.14	BSPI0: Slave Select
144	B3		P6.15	I/O	T _T		WUP9	2mA	X	X	Port 6.15	

1.4 Memory Mapping

Figure 5 shows the various memory configurations of the STR73xF system. The system memory map (from 0x0000_0000 to 0xFFFF_FFFF) is shown on the left part of the figure, the right part shows maps of the Flash and APB areas. For flexibility the Flash or RAM addresses can be aliased to Block 0 addresses using the remapping feature

Most reserved memory spaces (gray shaded areas in Figure 5) are protected from access by the user code. When an access this memory space is attempted, an ABORT signal is generated. Depending on the type of access, the ARM processor will enter “prefetch abort” state (Exception vector 0x0000_000C) or “data abort” state (Exception vector 0x0000_0010). It is up to the application software to manage these abort exceptions.

Figure 5. Memory Map

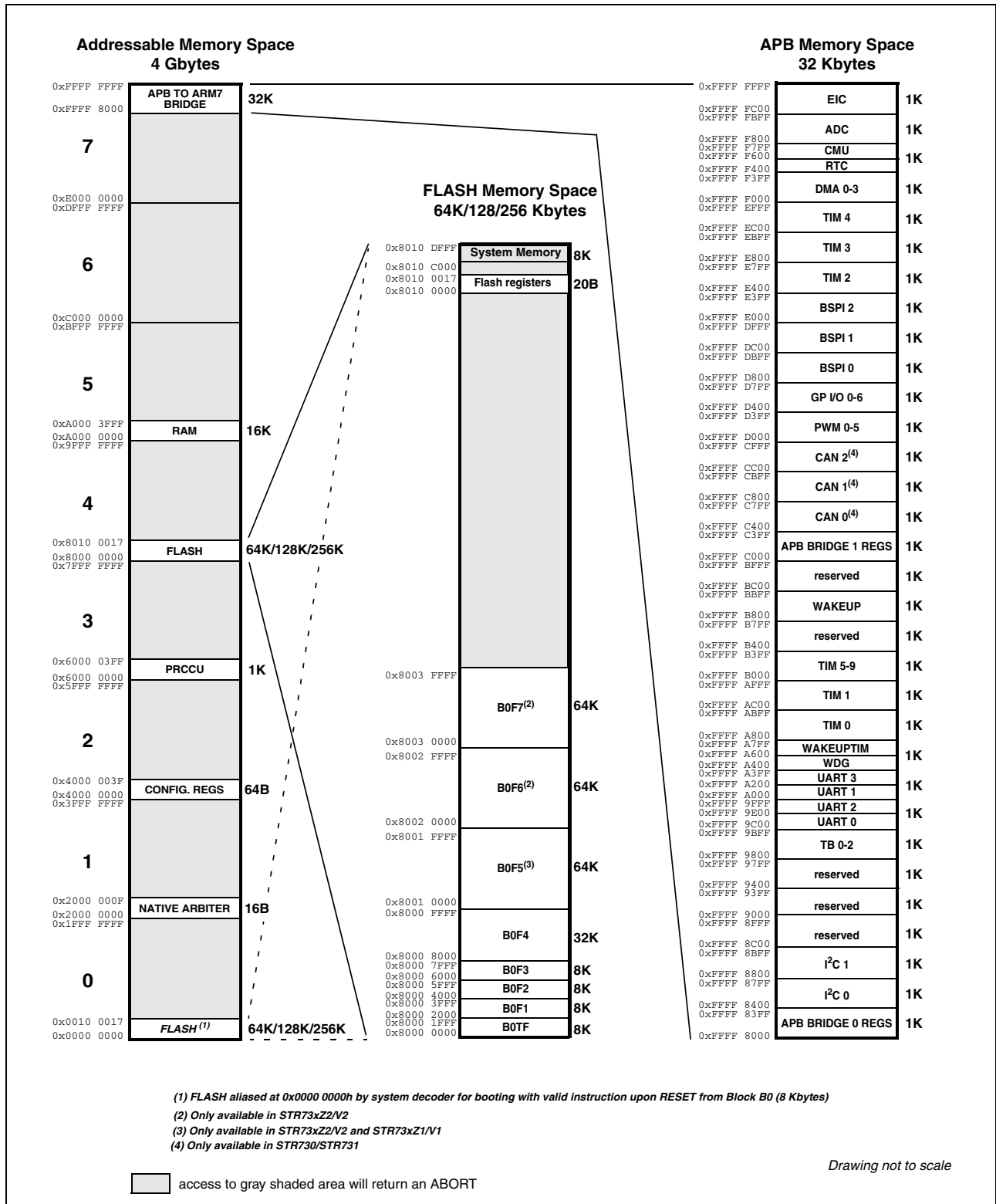

2 ORDER CODES

Table 4. Order Codes

Partnumber	FLASH Kbytes	Package	RAM Kbytes	TIM Timers	CAN Periph.	A/D Chan.	Wake-up Lines	I/O Ports	Temp. Range
STR730FZ1T7	128	TQFP144	16	10	3	16	32	112	-40 to +105°C
STR730FZ2T7	256	20x20							
STR730FZ1H7	128	LFBGA144							
STR730FZ2H7	256	10x10							
STR735FZ1T7	128	TQFP144							
STR735FZ2T7	256	20x20							
STR735FZ1H7	128	LFBGA144		6	0	12	18	72	
STR735FZ2H7	256	10x10							
STR731FV0T7	64	TQFP100							
STR731FV1T7	128	14x14							
STR731FV2T7	256								
STR736FV0T7	64	TQFP100							
STR736FV1T7	128	14x14							
STR736FV2T7	256								

Notes:

Information furnished is believed to be accurate and reliable. However, STMicroelectronics assumes no responsibility for the consequences of use of such information nor for any infringement of patents or other rights of third parties which may result from its use. No license is granted by implication or otherwise under any patent or patent rights of STMicroelectronics. Specifications mentioned in this publication are subject to change without notice. This publication supersedes and replaces all information previously supplied. STMicroelectronics products are not authorized for use as critical components in life support devices or systems without express written approval of STMicroelectronics.

The ST logo is a registered trademark of STMicroelectronics.

All other names are the property of their respective owners

© 2005 STMicroelectronics - All rights reserved

STMicroelectronics group of companies

Australia – Belgium - Brazil - Canada - China – Czech Republic - Finland - France - Germany - Hong Kong - India - Israel - Italy - Japan - Malaysia - Malta - Morocco - Singapore - Spain - Sweden - Switzerland - United Kingdom - United States of America

www.st.com