

8-bit MCU with single voltage Flash memory, ADC, timers

PRELIMINARY DATA

Features

■ Memories

- 2K Bytes single voltage Flash Program memory with read-out protection, In-Circuit and In-Application Programming (ICP and IAP). 10K write/erase cycles guaranteed, data retention: 20 years at 55°C
- 128 bytes RAM
- 128 bytes data EEPROM. 300K write/erase cycles guaranteed, data retention: 20 years at 55°C

■ Clock, Reset and Supply Management

- 3-level low voltage supervisor (LVD) and auxiliary voltage detector (AVD) for safe power-on/off procedures
- Clock sources: internal trimmable 8MHz RC oscillator, internal low power, low frequency RC oscillator or external clock
- Five Power Saving Modes: Halt, Auto Wake Up from Halt, Active-Halt, Wait and Slow

■ Interrupt Management

- 11 interrupt vectors plus TRAP and RESET
- 5 external interrupt lines (on 5 vectors)

■ I/O Ports

- 5 multifunctional bidirectional I/O lines
- 1 additional Output line
- 6 alternate function lines
- 5 high sink outputs

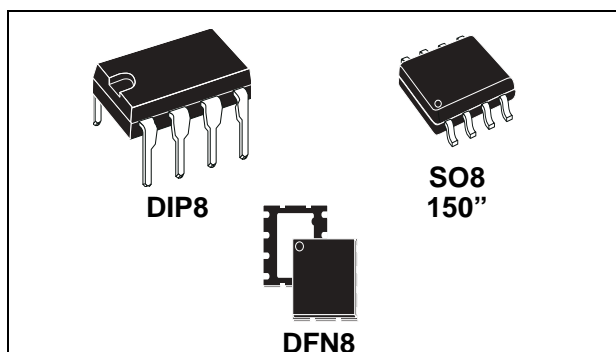

■ 2 Timers

- One 8-bit Lite Timer (LT) with prescaler including: watchdog, 1 realtime base and 1 input capture
- One 12-bit Auto-reload Timer (AT) with output compare function and PWM

■ A/D Converter

- 10-bit resolution for 0 to V_{DD}
- 5 input channels

■ Instruction Set

- 8-bit data manipulation
- 63 basic instructions with illegal opcode detection
- 17 main addressing modes
- 8 x 8 unsigned multiply instruction

■ Development Tools

- Full hardware/software development package
- Debug Module

Table 1. Device summary

| Features | ST7ULTRALITE | |
|------------------------|---|------------|
| | ST7LITEU05 | ST7LITEU09 |
| Program memory - bytes | 2K | |
| RAM (stack) - bytes | 128 (64) | |
| EEPROM -bytes | - | 128 |
| Peripherals | LT Timer w/ Wdg, AT Timer w/ 1 PWM | |
| ADC | 10-bit | |
| Operating Supply | 2.4V to 3.3V @ $f_{CPU}=4MHz$, 3.3V to 5.5V @ $f_{CPU}=8MHz$ | |
| CPU Frequency | up to 8MHz RC | |
| Operating Temperature | -40°C to +125°C | |
| Packages | SO8 150°, DIP8, DFN8, DIP16 ¹⁾ | |

Note 1: For development or tool prototyping purposes only. Not orderable in production quantities.

Rev. 1

| | |
|---|-----------|
| ST7LITEU05 | |
| ST7LITEU09 | 1 |
| 1 INTRODUCTION | 4 |
| 2 PIN DESCRIPTION | 5 |
| 3 REGISTER & MEMORY MAP | 8 |
| 4 FLASH PROGRAM MEMORY | 11 |
| 4.1 INTRODUCTION | 11 |
| 4.2 MAIN FEATURES | 11 |
| 4.3 PROGRAMMING MODES | 11 |
| 4.4 ICC INTERFACE | 12 |
| 4.5 MEMORY PROTECTION | 13 |
| 4.6 RELATED DOCUMENTATION | 13 |
| 4.7 REGISTER DESCRIPTION | 13 |
| 5 DATA EEPROM | 14 |
| 5.1 INTRODUCTION | 14 |
| 5.2 MAIN FEATURES | 14 |
| 5.3 MEMORY ACCESS | 15 |
| 5.4 POWER SAVING MODES | 17 |
| 5.5 ACCESS ERROR HANDLING | 17 |
| 5.6 DATA EEPROM READ-OUT PROTECTION | 17 |
| 5.7 REGISTER DESCRIPTION | 18 |
| 6 CENTRAL PROCESSING UNIT | 19 |
| 6.1 INTRODUCTION | 19 |
| 6.2 MAIN FEATURES | 19 |
| 6.3 CPU REGISTERS | 19 |
| 7 SUPPLY, RESET AND CLOCK MANAGEMENT | 22 |
| 7.1 INTERNAL RC OSCILLATOR ADJUSTMENT | 22 |
| 7.2 REGISTER DESCRIPTION | 24 |
| 7.3 RESET SEQUENCE MANAGER (RSM) | 27 |
| 7.4 REGISTER DESCRIPTION | 30 |
| 8 INTERRUPTS | 31 |
| 8.1 NON MASKABLE SOFTWARE INTERRUPT | 31 |
| 8.2 EXTERNAL INTERRUPTS | 31 |
| 8.3 PERIPHERAL INTERRUPTS | 31 |
| 8.4 SYSTEM INTEGRITY MANAGEMENT (SI) | 34 |
| 9 POWER SAVING MODES | 39 |
| 9.1 INTRODUCTION | 39 |
| 9.2 SLOW MODE | 39 |
| 9.3 WAIT MODE | 40 |
| 9.4 ACTIVE-HALT AND HALT MODES | 41 |
| 9.5 AUTO WAKE UP FROM HALT MODE | 43 |

| | |
|---|------------|
| 10 I/O PORTS | 47 |
| 10.1 INTRODUCTION | 47 |
| 10.2 FUNCTIONAL DESCRIPTION | 47 |
| 10.3 UNUSED I/O PINS | 51 |
| 10.4 LOW POWER MODES | 51 |
| 10.5 INTERRUPTS | 51 |
| 10.6 I/O PORT IMPLEMENTATION | 51 |
| 11 ON-CHIP PERIPHERALS | 53 |
| 11.1 LITE TIMER (LT) | 53 |
| 11.2 12-BIT AUTORELOAD TIMER (AT) | 58 |
| 11.3 10-BIT A/D CONVERTER (ADC) | 64 |
| 12 INSTRUCTION SET | 68 |
| 12.1 ST7 ADDRESSING MODES | 68 |
| 12.2 INSTRUCTION GROUPS | 71 |
| 13 ELECTRICAL CHARACTERISTICS | 74 |
| 13.1 PARAMETER CONDITIONS | 74 |
| 13.2 ABSOLUTE MAXIMUM RATINGS | 75 |
| 13.3 OPERATING CONDITIONS | 76 |
| 13.4 SUPPLY CURRENT CHARACTERISTICS | 81 |
| 13.5 CLOCK AND TIMING CHARACTERISTICS | 85 |
| 13.6 MEMORY CHARACTERISTICS | 86 |
| 13.7 EMC CHARACTERISTICS | 87 |
| 13.8 I/O PORT PIN CHARACTERISTICS | 90 |
| 13.9 CONTROL PIN CHARACTERISTICS | 96 |
| 13.10 10-BIT ADC CHARACTERISTICS | 98 |
| 14 PACKAGE CHARACTERISTICS | 101 |
| 14.1 PACKAGE MECHANICAL DATA | 101 |
| 14.2 SOLDERING INFORMATION | 104 |
| 15 DEVICE CONFIGURATION AND ORDERING INFORMATION | 105 |
| 15.1 OPTION BYTES | 105 |
| 15.2 ORDERING INFORMATION | 107 |
| 15.3 DEVELOPMENT TOOLS | 110 |
| 15.4 ST7 APPLICATION NOTES | 111 |
| 16 REVISION HISTORY | 114 |

1 INTRODUCTION

The ST7ULTRALITE is a member of the ST7 microcontroller family. All ST7 devices are based on a common industry-standard 8-bit core, featuring an enhanced instruction set.

The ST7ULTRALITE features FLASH memory with byte-by-byte In-Circuit Programming (ICP) and In-Application Programming (IAP) capability.

Under software control, the ST7ULTRALITE device can be placed in WAIT, SLOW, or HALT mode, reducing power consumption when the application is in idle or standby state.

The enhanced instruction set and addressing modes of the ST7 offer both power and flexibility to

software developers, enabling the design of highly efficient and compact application code. In addition to standard 8-bit data management, all ST7 microcontrollers feature true bit manipulation, 8x8 unsigned multiplication and indirect addressing modes.

For easy reference, all parametric data are located in [section 13 on page 74](#).

The devices feature an on-chip Debug Module (DM) to support in-circuit debugging (ICD). For a description of the DM registers, refer to the ST7 ICC Protocol Reference Manual.

Figure 1. General Block Diagram

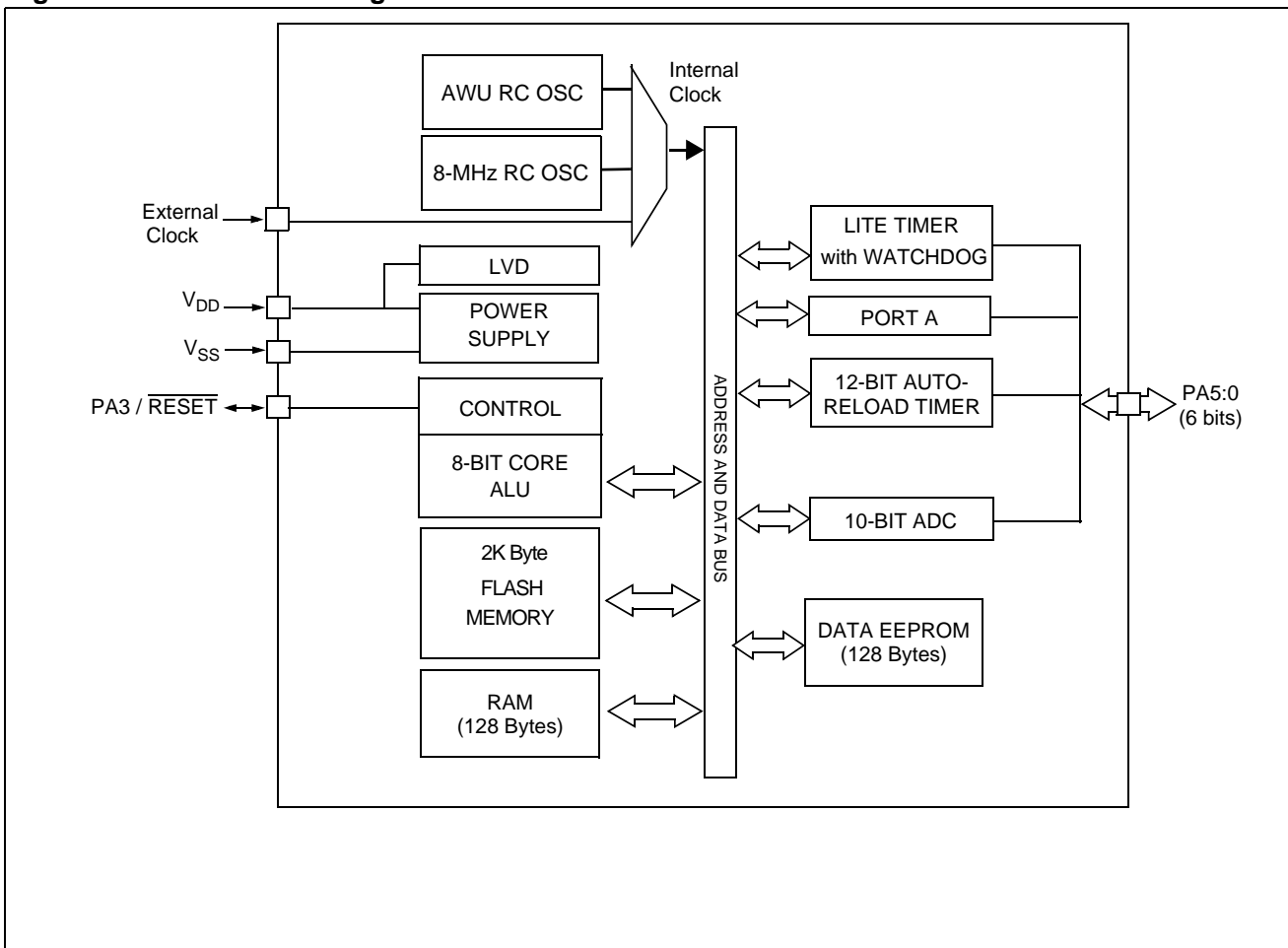

2 PIN DESCRIPTION

Figure 2. 8-pin SO and DIP Package Pinout

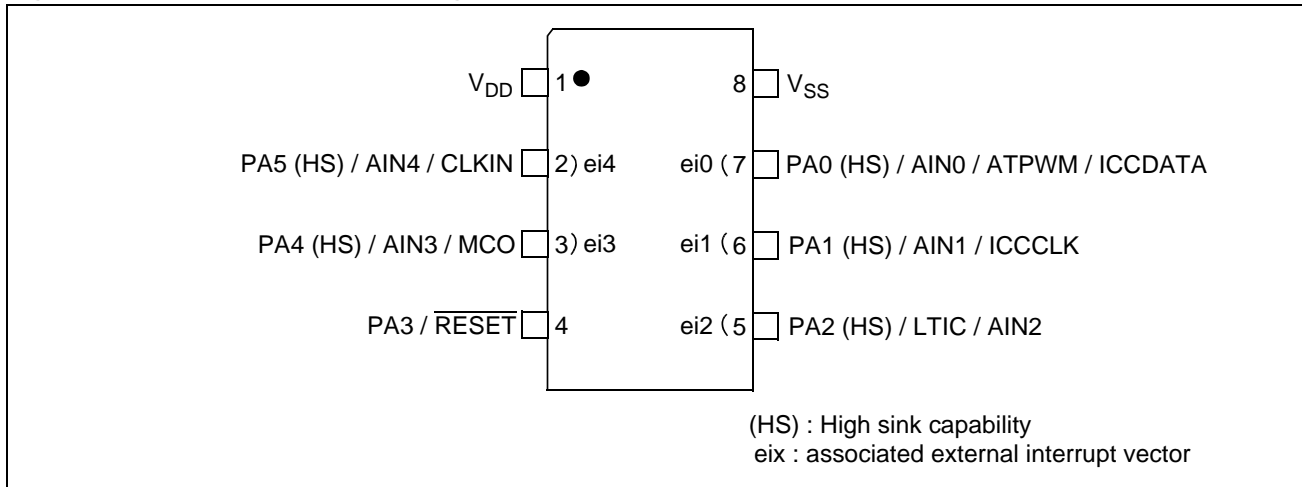
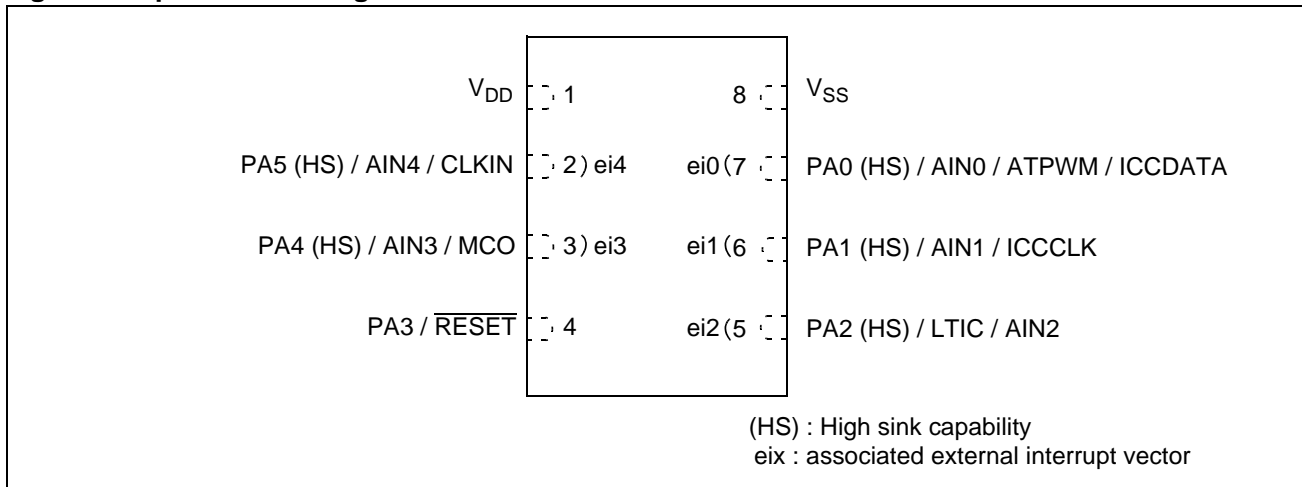
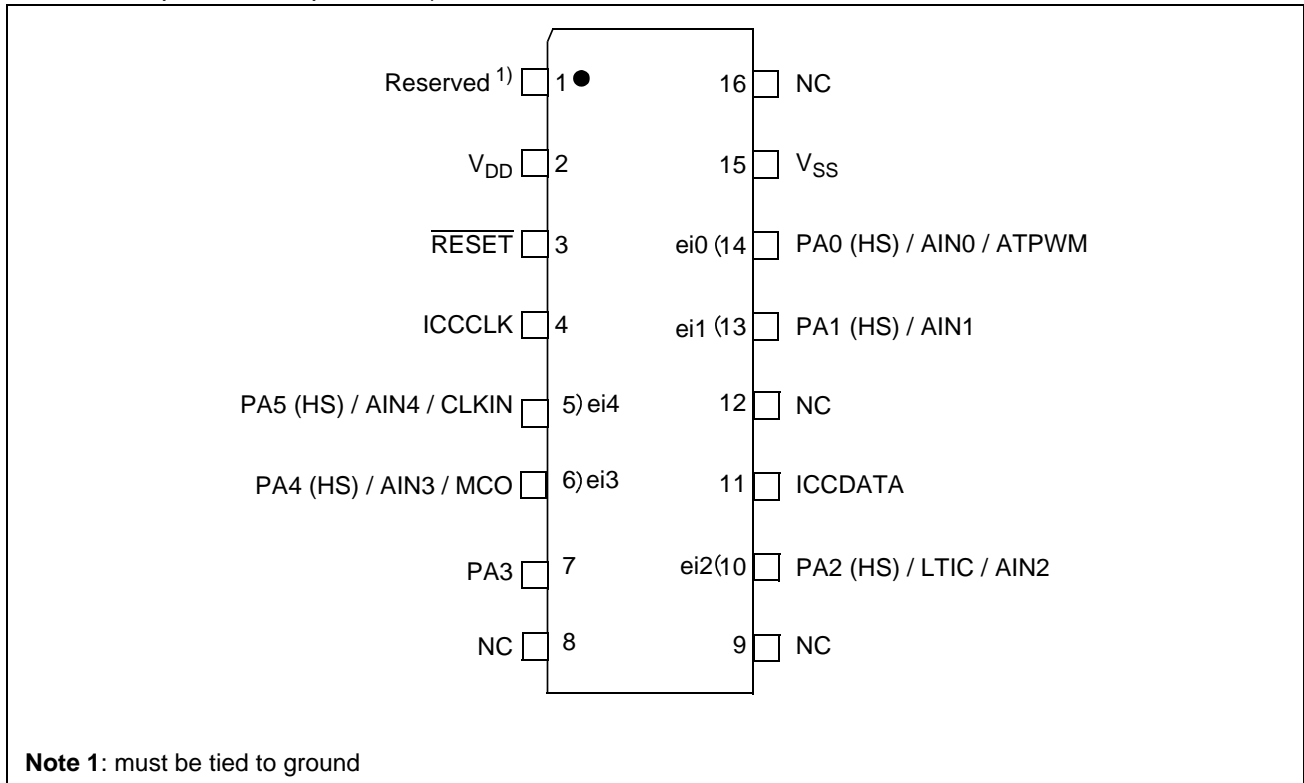

Figure 3. 8-pin DFN Package Pinout



PIN DESCRIPTION (Cont'd)

Figure 4. 16-Pin Package Pinout (For development or tool prototyping purposes only. Package not orderable in production quantities.)



Note:

The differences versus the 8-pin packages are listed below:

1. The ICC signals (ICCCLK and ICCDATA) are mapped on dedicated pins.
2. The RESET signal is mapped on a dedicated pin. It is not multiplexed with PA3.

3. PA3 pin is always configured as output. Any change on multiplexed IO reset control registers (MUXCR1 and MUXCR2) will have no effect on PA3 functionality. Refer to "REGISTER DESCRIPTION" on page 30.

PIN DESCRIPTION (Cont'd)

Legend / Abbreviations for Table 2:

Type: I = input, O = output, S = supply

In/Output level: $C_T = \text{CMOS } 0.3V_{DD}/0.7V_{DD}$ with input trigger

Output level: HS = High sink (on N-buffer only)

Port and control configuration:

– Input: float = floating, wpu = weak pull-up, int = interrupt, ana = analog

– Output: OD = open drain, PP = push-pull

The RESET configuration of each pin is shown in bold which is valid as long as the device is in reset state.

Table 2. Device Pin Description

| Pin No. | Pin Name | Type | Level | | Port / Control | | | | | | Main Function (after reset) | Alternate Function |
|---------|-------------------------------------|------|-------|--------|----------------|-----|-----|-----|--------|----------------|---|---------------------|
| | | | Input | Output | Input | | | | Output | | | |
| | | | | | float | wpu | int | ana | OD | PP | | |
| 1 | $V_{DD}^{1)}$ | S | | | | | | | | | | Main power supply |
| 2 | PA5/AIN4/CLKIN | I/O | C_T | HS | X | ei4 | X | X | X | Port A5 | Analog input 4 or External Clock Input | |
| 3 | PA4/AIN3/MCO | I/O | C_T | HS | X | ei3 | X | X | X | Port A4 | Analog input 3 or Main clock output | |
| 4 | PA3/ $\overline{\text{RESET}}^{2)}$ | O | | | | X | | | X | X | Port A3 | RESET ²⁾ |
| 5 | PA2/AIN2/LTIC | I/O | C_T | HS | X | ei2 | X | X | X | Port A2 | Analog input 2 or Lite Timer Input Capture | |
| 6 | PA1/AIN1/ICCCLK | I/O | C_T | HS | X | ei1 | X | X | X | Port A1 | Analog input 1 or In Circuit Communication Clock Caution: During normal operation this pin must be pulled-up, internally or externally (external pull-up of 10k mandatory in noisy environment). This is to avoid entering ICC mode unexpectedly during a reset. In the application, even if the pin is configured as output, any reset will put it back in pull-up | |
| 7 | PA0/AIN0/ATP-WM/ICCDATA | I/O | C_T | HS | X | ei0 | X | X | X | Port A0 | Analog input 0 or Auto-Reload Timer PWM or In Circuit Communication Data | |
| 8 | $V_{SS}^{1)}$ | S | | | | | | | | | | Ground |

Note:

1. It is mandatory to connect all available V_{DD} and V_{DDA} pins to the supply voltage and all V_{SS} and V_{SSA} pins to ground.

2. After a reset, the multiplexed PA3/RESET pin will act as $\overline{\text{RESET}}$. To configure this pin as output (Port A3), write 55h to MUXCR0 and AAh to MUXCR1. For further details, please refer to section 7.4 on page 30.

3 REGISTER & MEMORY MAP

As shown in [Figure 5](#), the MCU is capable of addressing 64K bytes of memories and I/O registers.

The available memory locations consist of 128 bytes of register locations, 128 bytes of RAM and 1 Kbytes of user program memory. The RAM space includes up to 64 bytes for the stack from 00C0h to 00FFh.

The highest address bytes contain the user reset and interrupt vectors.

The Flash memory contains two sectors (see [Figure 5](#)) mapped in the upper part of the ST7 addressing space so the reset and interrupt vectors are located in Sector 0 (FC00-FFFFh).

The size of Flash Sector 0 and other device options are configurable by Option byte.

IMPORTANT: Memory locations marked as “Reserved” must never be accessed. Accessing a reserved area can have unpredictable effects on the device.

Figure 5. Memory Map

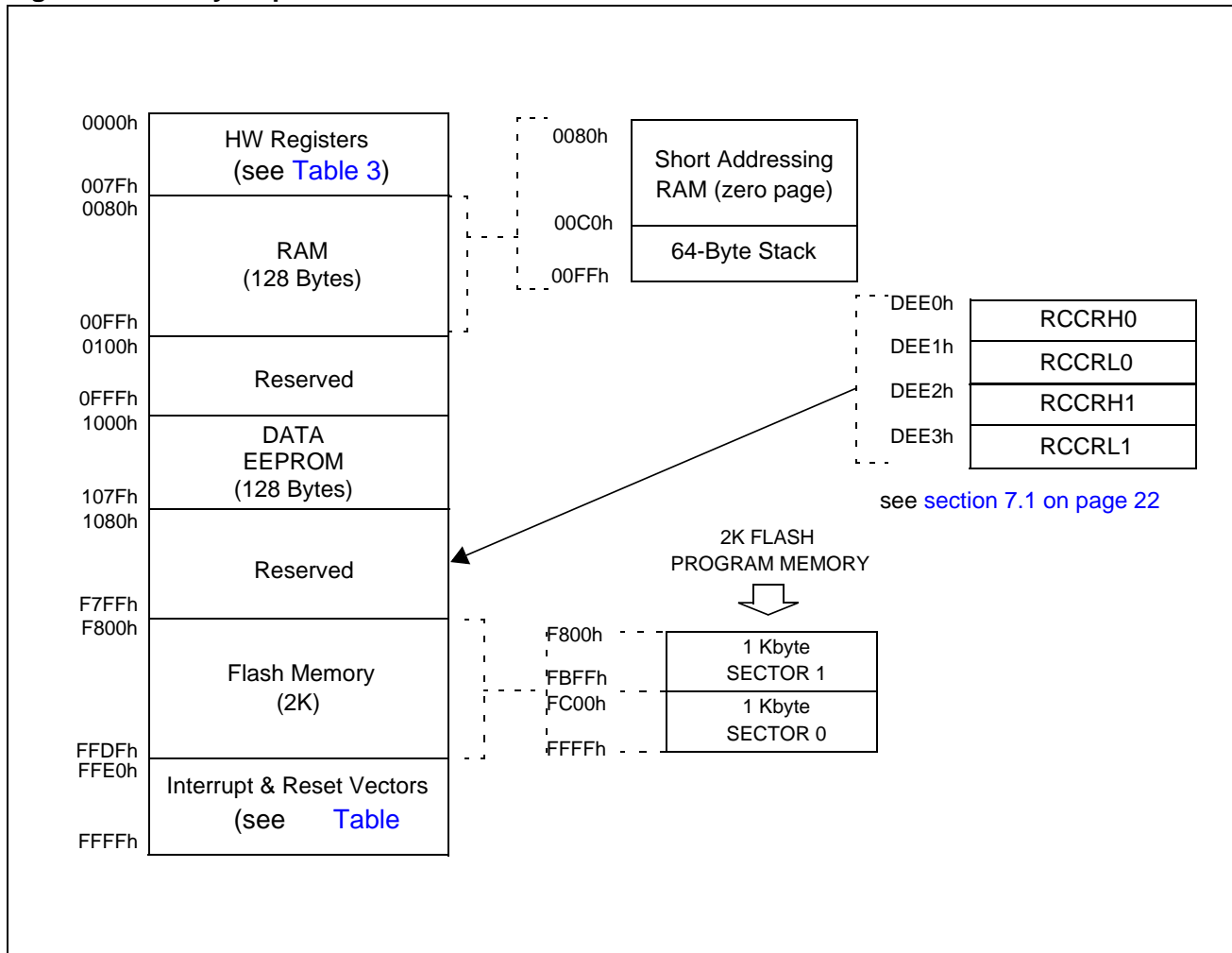

Note:

1. DEE0h, DEE1h, DEE2h and DEE3h addresses are located in a reserved area but are special bytes containing also the RC calibration values which are read-accessible only in user mode. If all the EEPROM data or Flash space (including the RC calibration values locations) has been erased (after the read-out protection removal), then the RC calibration values can still be obtained through these addresses.

Table 3. Hardware Register Map

| Address | Block | Register Label | Register Name | Reset Status | Remarks |
|---|--------------------------|---|---|---|---|
| 0000h 0001h 0002h | Port A | PADR PADDR PAOR | Port A Data Register Port A Data Direction Register Port A Option Register | 00h ¹⁾ 08h 02h ²⁾ | R/W R/W R/W |
| 0003h- 000Ah | Reserved area (8 bytes) | | | | |
| 000Bh 000Ch | LITE TIMER | LTCSR LTICR | Lite Timer Control/Status Register Lite Timer Input Capture Register | 0xh 00h | R/W Read Only |
| 000Dh 000Eh 000Fh 0010h 0011h 0012h 0013h | AUTO- RELOAD TIMER | ATCSR CNTRH CNTRL ATRH ATRL PWMCR PWM0CSR | Timer Control/Status Register Counter Register High Counter Register Low Auto-Reload Register High Auto-Reload Register Low PWM Output Control Register PWM 0 Control/Status Register | 00h 00h 00h 00h 00h 00h 00h | R/W Read Only Read Only R/W R/W R/W R/W |
| 0014h to 0016h | Reserved area (3 bytes) | | | | |
| 0017h 0018h | AUTO- RELOAD TIMER | DCR0H DCR0L | PWM 0 Duty Cycle Register High PWM 0 Duty Cycle Register Low | 00h 00h | R/W R/W |
| 0019h to 002Eh | Reserved area (22 bytes) | | | | |
| 002Fh | FLASH | FCSR | Flash Control/Status Register | 00h | R/W |
| 00030h | EEPROM | EECSR | Data EEPROM Control/Status Register | 00h | R/W |
| 0031h to 0033h | Reserved area (3 bytes) | | | | |
| 0034h 0035h 0036h | ADC | ADCCSR ADCDRH ADCDRL | A/D Control Status Register A/D Data Register High A/D Data Register Low | 00h xxh 00h | R/W Read Only R/W |
| 0037h | ITC | EICR1 | External Interrupt Control Register 1 | 00h | R/W |
| 0038h | MCC | MCCSR | Main Clock Control/Status Register | 00h | R/W |
| 0039h 003Ah | Clock and Reset | RCCR SICSR | RC oscillator Control Register System Integrity Control/Status Register | FFh 0000 0x00b | R/W R/W |
| 003Bh to 003Ch | Reserved area (2 bytes) | | | | |
| 003Dh | ITC | EICR2 | External Interrupt Control Register 2 | 00h | R/W |
| 003Eh | AVD | AVDTHCR | AVD Threshold Selection Register | 03h | R/W |
| 003Fh | Clock controller | CKCNTCSR | Clock Controller Control/Status Register | 09h | R/W |

| Address | Block | Register Label | Register Name | Reset Status | Remarks |
|--|--------------------------|--|---|--|--|
| 0040h to 0046h | Reserved area (7 bytes) | | | | |
| 0047h 0048h | MuxIO- reset | MUXCR0 MUXCR1 | Mux IO-Reset Control Register 0 Mux IO-Reset Control Register 1 | 00h 00h | R/W R/W |
| 0049h 004Ah | AWU | AWUPR AWUCSR | AWU Prescaler Register AWU Control/Status Register | FFh 00h | R/W R/W |
| 004Bh 004Ch 004Dh 004Eh 004Fh 0050h | DM ³⁾ | DMCR DMSR DMBK1H DMBK1L DMBK2H DMBK2L | DM Control Register DM Status Register DM Breakpoint Register 1 High DM Breakpoint Register 1 Low DM Breakpoint Register 2 High DM Breakpoint Register 2 Low | 00h 00h 00h 00h 00h 00h | R/W R/W R/W R/W R/W R/W |
| 0051h to 007Fh | Reserved area (47 bytes) | | | | |

Legend: x=undefined, R/W=read/write

Notes:

1. The contents of the I/O port DR registers are readable only in output configuration. In input configuration, the values of the I/O pins are returned instead of the DR register contents.
2. The bits associated with unavailable pins must always keep their reset value.
3. For a description of the DM registers, see the ST7 ICC Protocol Reference Manual.

4 FLASH PROGRAM MEMORY

4.1 Introduction

The ST7 single voltage extended Flash (XFlash) is a non-volatile memory that can be electrically erased and programmed either on a byte-by-byte basis or up to 32 bytes in parallel.

The XFlash devices can be programmed off-board (plugged in a programming tool) or on-board using In-Circuit Programming or In-Application Programming.

The array matrix organisation allows each sector to be erased and reprogrammed without affecting other sectors.

4.2 Main Features

- ICP (In-Circuit Programming)
- IAP (In-Application Programming)
- ICT (In-Circuit Testing) for downloading and executing user application test patterns in RAM
- Sector 0 size configurable by option byte
- Read-out and write protection

4.3 PROGRAMMING MODES

The ST7 can be programmed in three different ways:

- Insertion in a programming tool. In this mode, FLASH sectors 0 and 1 and option byte row can be programmed or erased.
- In-Circuit Programming. In this mode, FLASH sectors 0 and 1 and option byte row can be programmed or erased without removing the device from the application board.
- In-Application Programming. In this mode, sector 1 can be programmed or erased without removing the device from the application board and while the application is running.

4.3.1 In-Circuit Programming (ICP)

ICP uses a protocol called ICC (In-Circuit Communication) which allows an ST7 plugged on a printed circuit board (PCB) to communicate with an external programming device connected via cable. ICP is performed in three steps:

- Switch the ST7 to ICC mode (In-Circuit Communications). This is done by driving a specific signal sequence on the ICCCLK/DATA pins while the RESET pin is pulled low. When the ST7 enters ICC mode, it fetches a specific RESET vector which points to the ST7 System Memory containing the ICC protocol routine. This routine enables the ST7 to receive bytes from the ICC interface.
- Download ICP Driver code in RAM from the IC-CDATA pin
- Execute ICP Driver code in RAM to program the FLASH memory

Depending on the ICP Driver code downloaded in RAM, FLASH memory programming can be fully customized (number of bytes to program, program locations, or selection of the serial communication interface for downloading).

4.3.2 In Application Programming (IAP)

This mode uses an IAP Driver program previously programmed in Sector 0 by the user (in ICP mode).

This mode is fully controlled by user software. This allows it to be adapted to the user application, (user-defined strategy for entering programming mode, choice of communications protocol used to fetch the data to be stored etc.)

IAP mode can be used to program any memory areas except Sector 0, which is write/erase protected to allow recovery in case errors occur during the programming operation.

FLASH PROGRAM MEMORY (Cont'd)

4.4 ICC interface

ICP needs a minimum of 4 and up to 6 pins to be connected to the programming tool. These pins are:

- $\overline{\text{RESET}}$: device reset
- V_{SS} : device power supply ground
- ICCCLK: ICC output serial clock pin (see note 1)
- ICCDATA: ICC input serial data pin
- CLKIN: main clock input for external source
- V_{DD} : application board power supply (see Note 3)

Figure 6. Typical ICC Interface

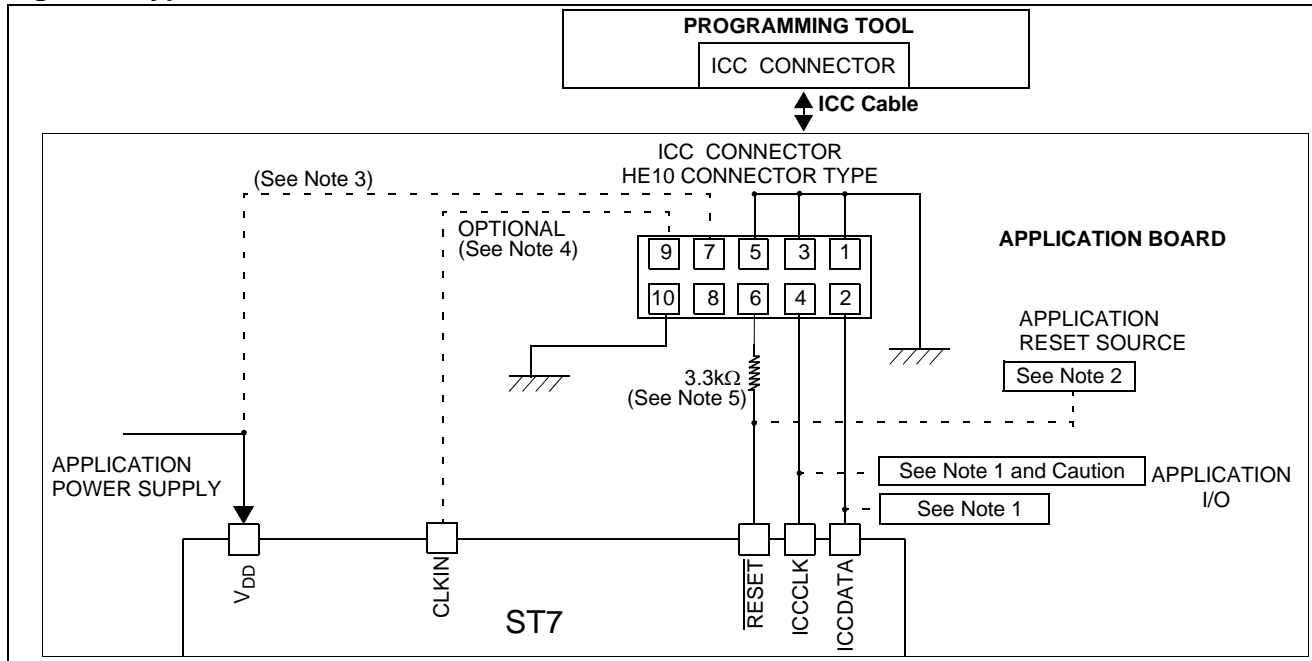

Notes:

1. If the ICCCLK or ICCDATA pins are only used as outputs in the application, no signal isolation is necessary. As soon as the Programming Tool is plugged to the board, even if an ICC session is not in progress, the ICCCLK and ICCDATA pins are not available for the application. If they are used as inputs by the application, isolation such as a serial resistor has to be implemented in case another device forces the signal. Refer to the Programming Tool documentation for recommended resistor values.

2. During the ICP session, the programming tool must control the $\overline{\text{RESET}}$ pin. This can lead to conflicts between the programming tool and the application reset circuit if it drives more than 5mA at high level (push pull output or pull-up resistor < 1K). A schottky diode can be used to isolate the application RESET circuit in this case. When using a classical RC network with $R > 1K$ or a reset man-

agement IC with open drain output and pull-up resistor > 1K, no additional components are needed. In all cases the user must ensure that no external reset is generated by the application during the ICC session.

3. The use of Pin 7 of the ICC connector depends on the Programming Tool architecture. This pin must be connected when using most ST Programming Tools (it is used to monitor the application power supply). Please refer to the Programming Tool manual.

4. Pin 9 has to be connected to the CLKIN pin of the ST7 when ICC mode is selected with option bytes disabled (35-pulse ICC entry mode). When option bytes are enabled (38-pulse ICC entry mode), the internal RC clock is forced, regardless of the selection in the option byte.

FLASH PROGRAM MEMORY (Cont'd)

5. A serial resistor must be connected to ICC connector pin 6 in order to prevent contention on PA3/RESET pin. Contention may occur if a tool forces a state on RESET pin while PA3 pin forces the opposite state in output mode. The resistor value is defined to limit the current below 2mA at 5V. If PA3 is used as output push-pull, then the application must be switched off to allow the tool to take control of the RESET pin (PA3). To allow the programming tool to drive the RESET pin below V_{IL} , special care must also be taken when a pull-up is placed on PA3 for application reasons.

Caution: During normal operation, ICCCLK pin must be pulled-up, internally or externally (external pull-up of 10k mandatory in noisy environment). This is to avoid entering ICC mode unexpectedly during a reset. In the application, even if the pin is configured as output, any reset will put it back in input pull-up.

4.5 Memory Protection

There are two different types of memory protection: read-out protection and Write/Erase Protection which can be applied individually.

4.5.1 Read-out Protection

Readout protection, when selected provides a protection against program memory content extraction and against write access to Flash memory. Even if no protection can be considered as totally unbreakable, the feature provides a very high level of protection for a general purpose microcontroller. Program memory is protected.

In flash devices, this protection is removed by reprogramming the option. In this case, program memory is automatically erased, and the device can be reprogrammed.

Read-out protection selection depends on the device type:

- In Flash devices it is enabled and removed through the FMP_R bit in the option byte.
- In ROM devices it is enabled by mask option specified in the Option List.

4.5.2 Flash Write/Erase Protection

Write/erase protection, when set, makes it impossible to both overwrite and erase program memory. Its purpose is to provide advanced security to applications and prevent any change being made to the memory content.

Warning: Once set, Write/erase protection can never be removed. A write-protected flash device is no longer reprogrammable.

Write/erase protection is enabled through the FMP_W bit in the option byte.

4.6 Related Documentation

For details on Flash programming and ICC protocol, refer to the ST7 Flash Programming Reference Manual and to the ST7 ICC Protocol Reference Manual.

4.7 Register Description

FLASH CONTROL/STATUS REGISTER (FCSR)

Read/Write

Reset Value: 000 0000 (00h)

1st RASS Key: 0101 0110 (56h)

2nd RASS Key: 1010 1110 (AEh)

| | | | | | | | |
|---|---|---|---|---|-----|-----|-----|
| 7 | | | | | | | 0 |
| 0 | 0 | 0 | 0 | 0 | OPT | LAT | PGM |

Note: This register is reserved for programming using ICP, IAP or other programming methods. It controls the XFlash programming and erasing operations.

When an EPB or another programming tool is used (in socket or ICP mode), the RASS keys are sent automatically.

Table 4. FLASH Register Map and Reset Values

| Address (Hex.) | Register Label | 7 | 6 | 5 | 4 | 3 | 2 | 1 | 0 |
|----------------|---------------------|---|---|---|---|---|----------|----------|----------|
| 002Fh | FCSR Reset Value | 0 | 0 | 0 | 0 | 0 | OPT 0 | LAT 0 | PGM 0 |

5 DATA EEPROM

5.1 INTRODUCTION

The Electrically Erasable Programmable Read Only Memory can be used as a non volatile back-up for storing data. Using the EEPROM requires a basic access protocol described in this chapter.

5.2 MAIN FEATURES

- Up to 32 Bytes programmed in the same cycle
- EEPROM mono-voltage (charge pump)
- Chained erase and programming cycles
- Internal control of the global programming cycle duration
- WAIT mode management
- Readout protection

Figure 7. EEPROM Block Diagram

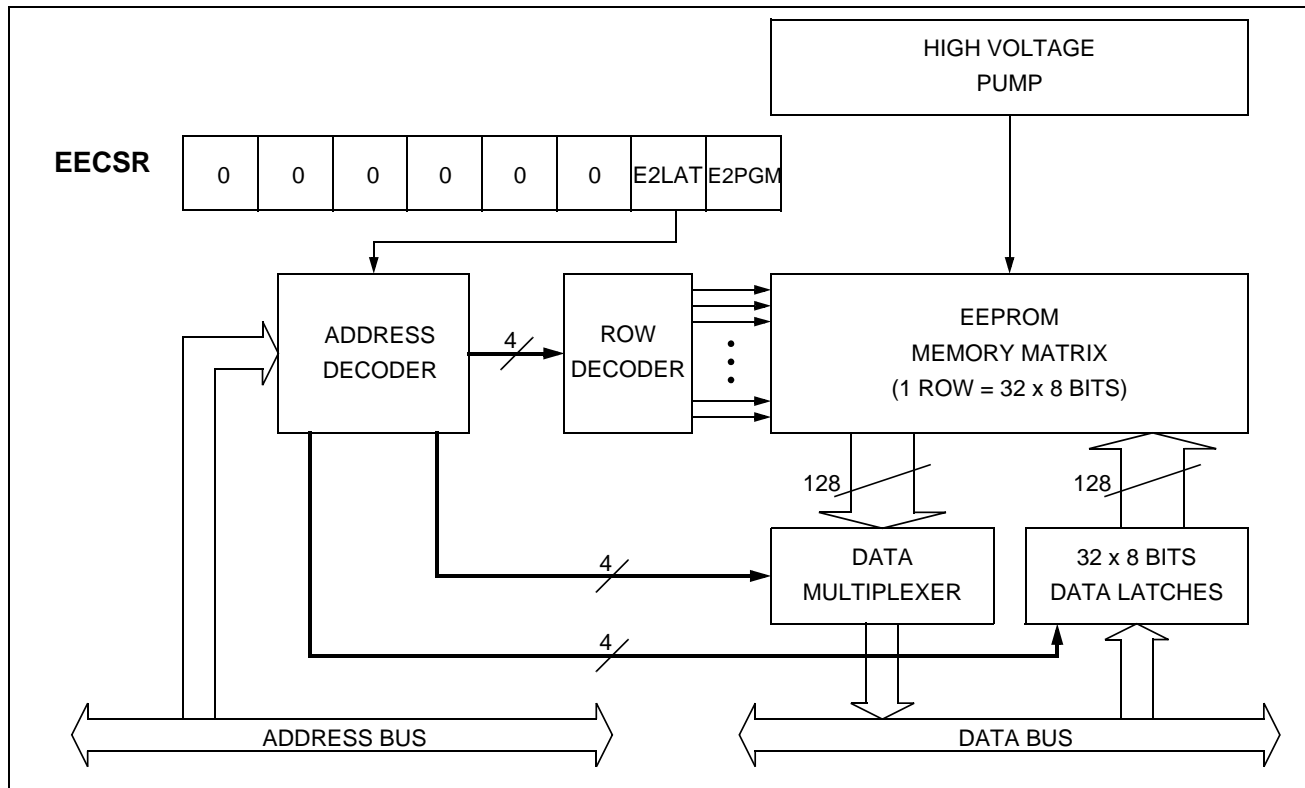

DATA EEPROM (Cont'd)

5.3 MEMORY ACCESS

The Data EEPROM memory read/write access modes are controlled by the E2LAT bit of the EEPROM Control/Status register (EECSR). The flowchart in [Figure 8](#) describes these different memory access modes.

Read Operation (E2LAT=0)

The EEPROM can be read as a normal ROM location when the E2LAT bit of the EECSR register is cleared.

On this device, Data EEPROM can also be used to execute machine code. Take care not to write to the Data EEPROM while executing from it. This would result in an unexpected code being executed.

Write Operation (E2LAT=1)

To access the write mode, the E2LAT bit has to be set by software (the E2PGM bit remains cleared). When a write access to the EEPROM area occurs,

the value is latched inside the 32 data latches according to its address.

When PGM bit is set by the software, all the previous bytes written in the data latches (up to 32) are programmed in the EEPROM cells. The effective high address (row) is determined by the last EEPROM write sequence. To avoid wrong programming, the user must take care that all the bytes written between two programming sequences have the same high address: only the five Least Significant Bits of the address can change.

At the end of the programming cycle, the PGM and LAT bits are cleared simultaneously.

Note: Care should be taken during the programming cycle. Writing to the same memory location will over-program the memory (logical AND between the two write access data result) because the data latches are only cleared at the end of the programming cycle and by the falling edge of the E2LAT bit.

It is not possible to read the latched data. This note is illustrated by the [Figure 10](#).

Figure 8. Data EEPROM Programming Flowchart

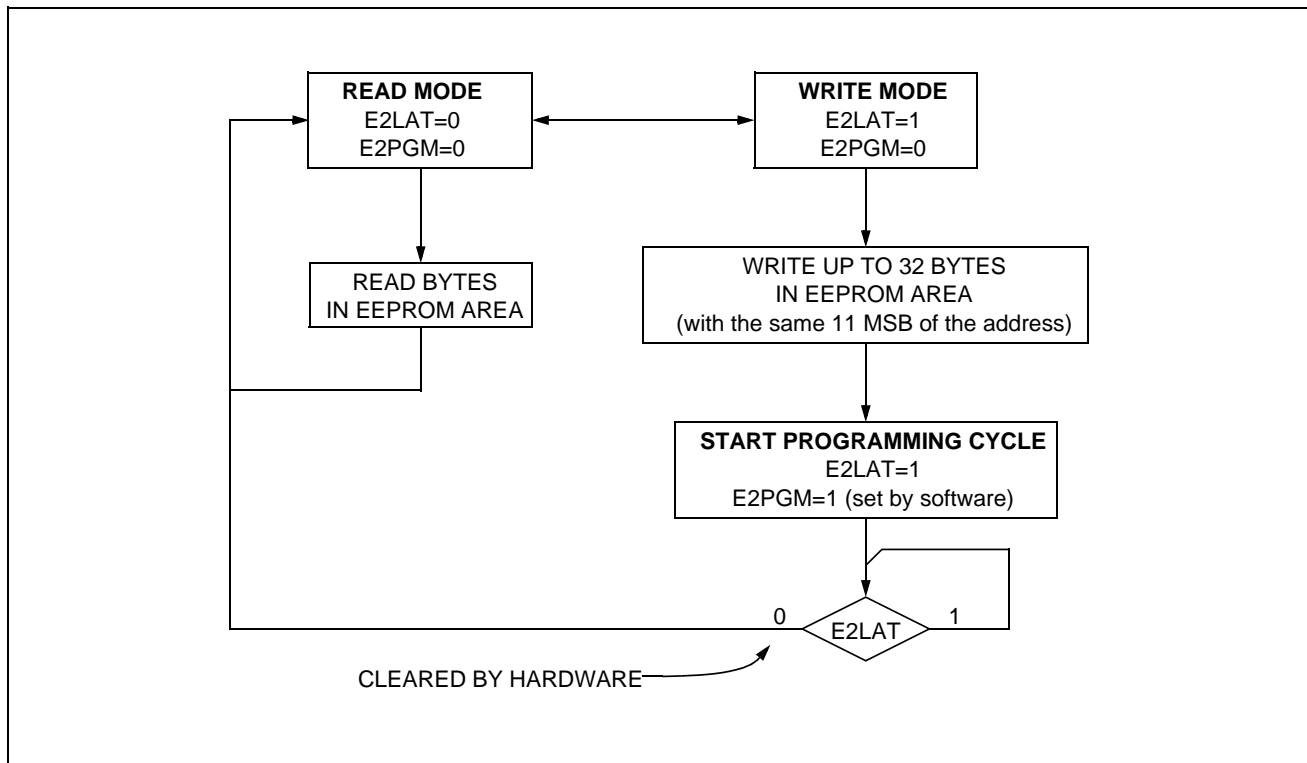

DATA EEPROM (Cont'd)

Figure 9. Data E²PROM Write Operation

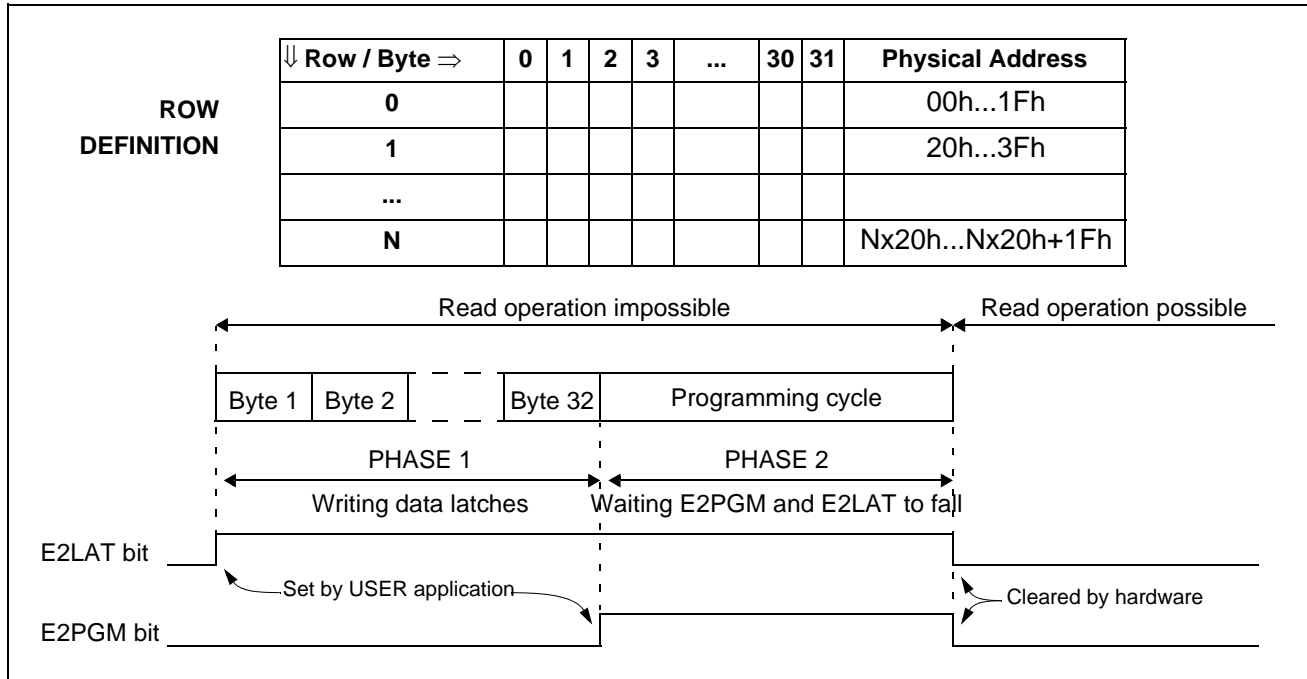

Note: If a programming cycle is interrupted (by a reset action), the integrity of the data in memory is not guaranteed.

DATA EEPROM (Cont'd)

5.4 POWER SAVING MODES

Wait mode

The DATA EEPROM can enter WAIT mode on execution of the WFI instruction of the microcontroller or when the microcontroller enters Active-HALT mode. The DATA EEPROM will immediately enter this mode if there is no programming in progress, otherwise the DATA EEPROM will finish the cycle and then enter WAIT mode.

Active-Halt mode

Refer to Wait mode.

Halt mode

The DATA EEPROM immediately enters HALT mode if the microcontroller executes the HALT instruction. Therefore the EEPROM will stop the function in progress, and data may be corrupted.

5.5 ACCESS ERROR HANDLING

If a read access occurs while E2LAT=1, then the data bus will not be driven.

If a write access occurs while E2LAT=0, then the data on the bus will not be latched.

If a programming cycle is interrupted (by a RESET action), the integrity of the data in memory will not be guaranteed.

5.6 Data EEPROM Read-out Protection

The read-out protection is enabled through an option bit (see option byte section).

When this option is selected, the programs and data stored in the EEPROM memory are protected against read-out (including a re-write protection). In Flash devices, when this protection is removed by reprogramming the Option Byte, the entire Program memory and EEPROM is first automatically erased.

Note: Both Program Memory and data EEPROM are protected using the same option bit.

Figure 10. Data EEPROM Programming Cycle

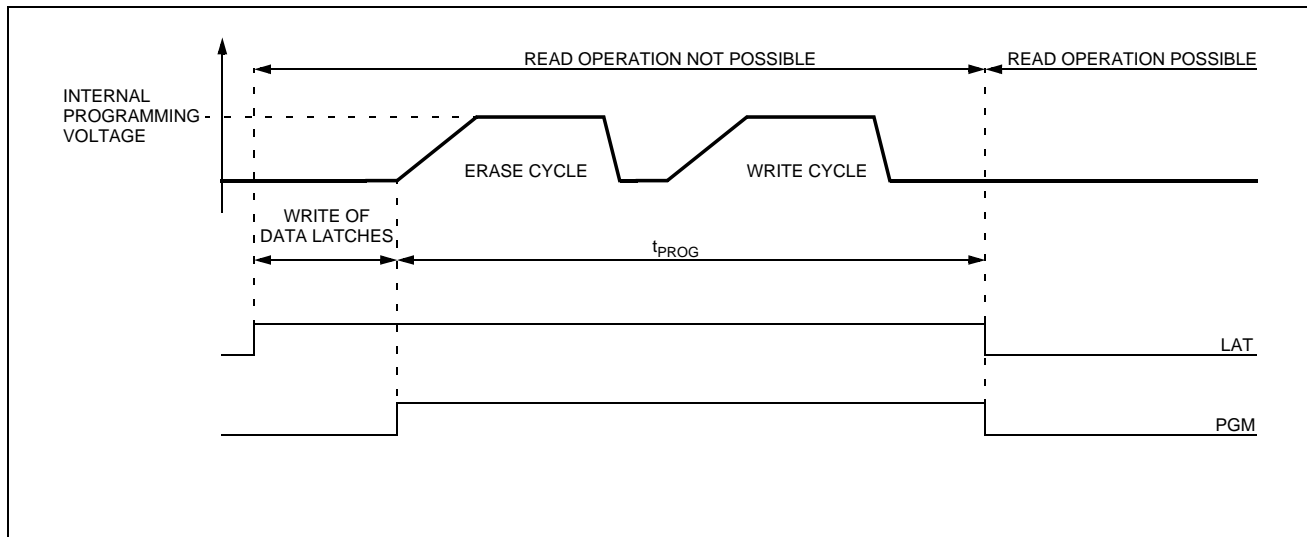

DATA EEPROM (Cont'd)

5.7 REGISTER DESCRIPTION

EEPROM CONTROL/STATUS REGISTER (EECSR)

Read/Write

Reset Value: 0000 0000 (00h)

| | | | | | | | |
|---|---|---|---|---|---|-------|-------|
| 7 | | | | | | | 0 |
| 0 | 0 | 0 | 0 | 0 | 0 | E2LAT | E2PGM |

Bits 7:2 = Reserved, forced by hardware to 0.

Bit 1 = **E2LAT** *Latch Access Transfer*

This bit is set by software. It is cleared by hardware at the end of the programming cycle. It can only be cleared by software if the E2PGM bit is cleared.

0: Read mode

1: Write mode

Bit 0 = **E2PGM** *Programming control and status*

This bit is set by software to begin the programming cycle. At the end of the programming cycle, this bit is cleared by hardware.

0: Programming finished or not yet started

1: Programming cycle is in progress

Note: if the E2PGM bit is cleared during the programming cycle, the memory data is not guaranteed

Table 5. DATA EEPROM Register Map and Reset Values

| Address (Hex.) | Register Label | 7 | 6 | 5 | 4 | 3 | 2 | 1 | 0 |
|----------------|----------------------|---|---|---|---|---|---|------------|------------|
| 0030h | EECSR Reset Value | 0 | 0 | 0 | 0 | 0 | 0 | E2LAT 0 | E2PGM 0 |

CPU REGISTERS (cont'd)

CONDITION CODE REGISTER (CC)

Read/Write

Reset Value: 111x1xxx

| | | | | | | | |
|---|---|---|---|---|---|---|---|
| 7 | | | | | | | 0 |
| 1 | 1 | 1 | H | I | N | Z | C |

The 8-bit Condition Code register contains the interrupt mask and four flags representative of the result of the instruction just executed. This register can also be handled by the PUSH and POP instructions.

These bits can be individually tested and/or controlled by specific instructions.

Bit 4 = **H** *Half carry*

This bit is set by hardware when a carry occurs between bits 3 and 4 of the ALU during an ADD or ADC instruction. It is reset by hardware during the same instructions.

0: No half carry has occurred.
1: A half carry has occurred.

This bit is tested using the JRH or JRNH instruction. The H bit is useful in BCD arithmetic subroutines.

Bit 3 = **I** *Interrupt mask*

This bit is set by hardware when entering in interrupt or by software to disable all interrupts except the TRAP software interrupt. This bit is cleared by software.

0: Interrupts are enabled.
1: Interrupts are disabled.

This bit is controlled by the RIM, SIM and IRET instructions and is tested by the JRM and JRNM instructions.

Note: Interrupts requested while I is set are latched and can be processed when I is cleared. By default an interrupt routine is not interruptible

because the I bit is set by hardware at the start of the routine and reset by the IRET instruction at the end of the routine. If the I bit is cleared by software in the interrupt routine, pending interrupts are serviced regardless of the priority level of the current interrupt routine.

Bit 2 = **N** *Negative*

This bit is set and cleared by hardware. It is representative of the result sign of the last arithmetic, logical or data manipulation. It is a copy of the 7th bit of the result.

0: The result of the last operation is positive or null.
1: The result of the last operation is negative (that is, the most significant bit is a logic 1).

This bit is accessed by the JRMI and JRPL instructions.

Bit 1 = **Z** *Zero*

This bit is set and cleared by hardware. This bit indicates that the result of the last arithmetic, logical or data manipulation is zero.

0: The result of the last operation is different from zero.
1: The result of the last operation is zero.

This bit is accessed by the JREQ and JRNE test instructions.

Bit 0 = **C** *Carry/borrow*

This bit is set and cleared by hardware and software. It indicates an overflow or an underflow has occurred during the last arithmetic operation.

0: No overflow or underflow has occurred.
1: An overflow or underflow has occurred.

This bit is driven by the SCF and RCF instructions and tested by the JRC and JRNC instructions. It is also affected by the "bit test and branch", shift and rotate instructions.

CPU REGISTERS (Cont'd)

Stack Pointer (SP)

Read/Write

Reset Value: 00 FFh

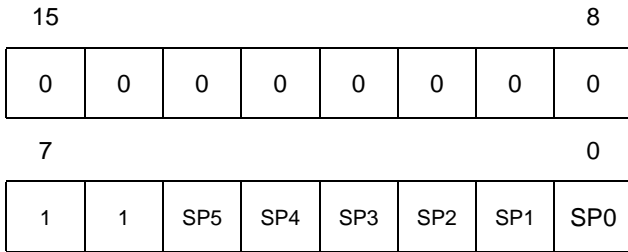

The Stack Pointer is a 16-bit register which is always pointing to the next free location in the stack. It is then decremented after data has been pushed onto the stack and incremented before data is popped from the stack (see Figure 12).

Since the stack is 64 bytes deep, the 10 most significant bits are forced by hardware. Following an MCU Reset, or after a Reset Stack Pointer instruction (RSP), the Stack Pointer contains its reset value (the SP5 to SP0 bits are set) which is the stack higher address.

The least significant byte of the Stack Pointer (called S) can be directly accessed by a LD instruction.

Note: When the lower limit is exceeded, the Stack Pointer wraps around to the stack upper limit, without indicating the stack overflow. The previously stored information is then overwritten and therefore lost. The stack also wraps in case of an underflow.

The stack is used to save the return address during a subroutine call and the CPU context during an interrupt. The user may also directly manipulate the stack by means of the PUSH and POP instructions. In the case of an interrupt, the PCL is stored at the first location pointed to by the SP. Then the other registers are stored in the next locations as shown in Figure 12.

- When an interrupt is received, the SP is decremented and the context is pushed on the stack.
- On return from interrupt, the SP is incremented and the context is popped from the stack.

A subroutine call occupies two locations and an interrupt five locations in the stack area.

Figure 12. . Stack Manipulation Example

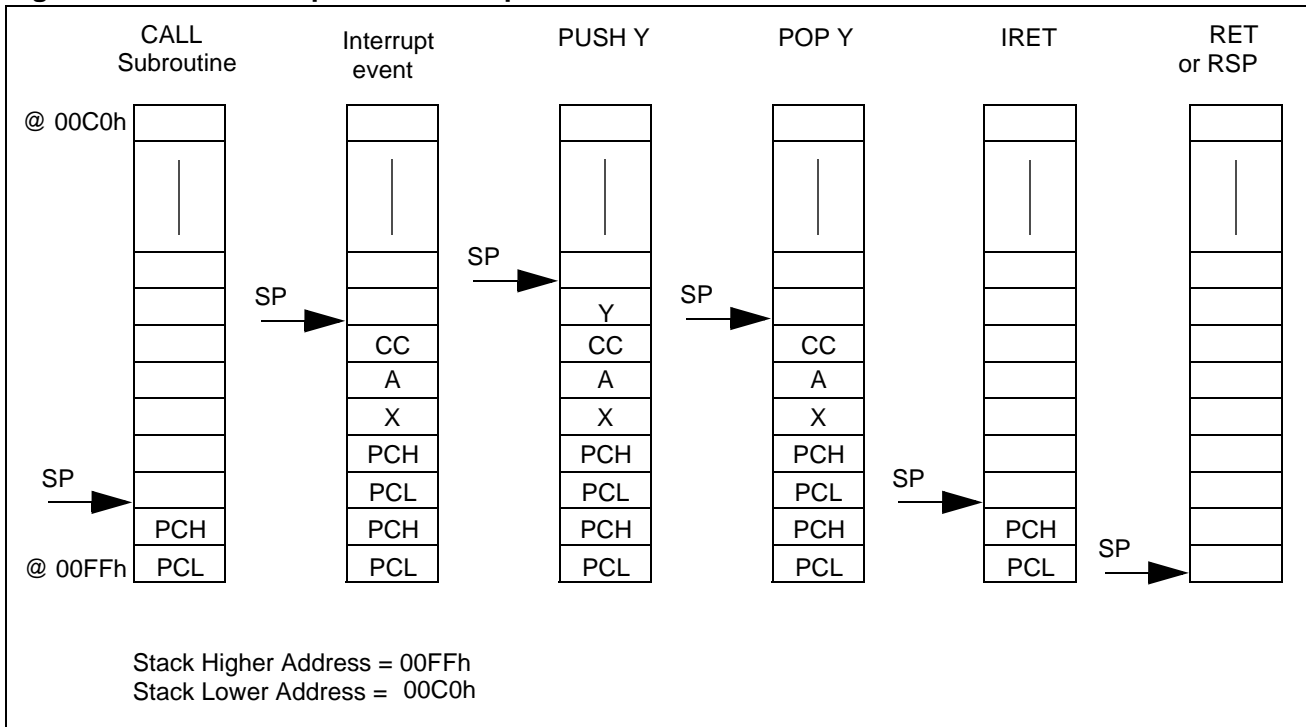

7 SUPPLY, RESET AND CLOCK MANAGEMENT

The device includes a range of utility features for securing the application in critical situations (for example in case of a power brown-out), and reducing the number of external components.

Main features

- Clock Management
 - 8 MHz internal RC oscillator (enabled by option byte)
 - External Clock Input (enabled by option byte)
- Reset Sequence Manager (RSM)
- System Integrity Management (SI)
 - Main supply Low voltage detection (LVD) with reset generation (enabled by option byte)
 - Auxiliary Voltage detector (AVD) with interrupt capability for monitoring the main supply

7.1 INTERNAL RC OSCILLATOR ADJUSTMENT

The ST7 contains an internal RC oscillator with a specific accuracy for a given device, temperature and voltage. It can be selected as the start up clock through the CKSEL[1:0] option bits (see [section 15.1 on page 105](#)). It must be calibrated to obtain the frequency required in the application. This is done by software writing a 10-bit calibration value in the RCCR (RC Control Register) and in the bits [6:5] in the SICSR (SI Control Status Register).

Whenever the microcontroller is reset, the RCCR returns to its default value (FFh), i.e. each time the device is reset, the calibration value must be loaded in the RCCR. Predefined calibration values are stored in Flash memory for 3.3 and 5V V_{DD} supply voltages at 25°C, as shown in the following table.

| RCCR | Conditions | ST7LITEU05/ ST7LITEU09 Address |
|--------|---|--------------------------------------|
| RCCRH0 | $V_{DD}=5V$ $T_A=25^{\circ}C$ $f_{RC}=8MHz$ | DEE0h ¹⁾ (CR[9:2] bits) |
| RCCRL0 | | DEE1h ¹⁾ (CR[1:0] bits) |
| RCCRH1 | $V_{DD}=3.3V$ $T_A=25^{\circ}C$ $f_{RC}=8MHz$ | DEE2h ¹⁾ (CR[9:2] bits) |
| RCCRL1 | | DEE3h ¹⁾ (CR[1:0] bits) |

1. DEE0h, DEE1h, DEE2h and DEE3h are located in a reserved area but are special bytes containing also the RC calibration values which are read-accessible only in user mode. If all the Flash space (including the RC calibration value locations) has been erased (after the read-out protection remov-

al), then the RC calibration values can still be obtained through these two address.

Notes:

- In ICC mode, the internal RC oscillator is forced as a clock source, regardless of the selection in the option byte. Refer to note 5 in [section 4.4 on page 12](#) for further details.
- See “ELECTRICAL CHARACTERISTICS” on page 74. for more information on the frequency and accuracy of the RC oscillator.
- To improve clock stability and frequency accuracy, it is recommended to place a decoupling capacitor, typically 100nF, between the V_{DD} and V_{SS} pins as close as possible to the ST7 device.

Caution: If the voltage or temperature conditions change in the application, the frequency may need to be recalibrated.

Refer to application note AN2326 for information on how to calibrate the RC frequency using an external reference signal.

The ST7ULTRALITE also contains an Auto Wake Up RC oscillator. This RC oscillator should be enabled to enter Auto Wake-up from Halt mode.

The Auto Wake Up RC oscillator can also be configured as the startup clock through the CKSEL[1:0] option bits (see [section 15.1 on page 105](#)).

This is recommended for applications where very low power consumption is required.

Switching from one startup clock to another can be done in run mode as follows (see [Figure 13](#)):

Case 1: Switching from internal RC to AWU:

- 1. Set the RC/AWU bit in the CKCNTCSR register to enable the AWU RC oscillator
- 2. The RC_FLAG is cleared and the clock output is at 1.
- 3. Wait 3 AWU RC cycles till the AWU_FLAG is set
- 4. The switch to the AWU clock is made at the positive edge of the AWU clock signal
- 5. Once the switch is made, the internal RC is stopped

Case 2: Switching from AWU RC to internal RC:

- 1. Reset the RC/AWU bit to enable the internal RC oscillator

SUPPLY, RESET AND CLOCK MANAGEMENT (Cont'd)

- 2. Using a 4-bit counter, wait until 8 internal RC cycles have elapsed. The counter is running on internal RC clock.
- 3. Wait till the AWU_FLAG is cleared (1AWU RC cycle) and the RC_FLAG is set (2 RC cycles)
- 4. The switch to the internal RC clock is made at the positive edge of the internal RC clock signal
- 5. Once the switch is made, the AWU RC is stopped

Notes:

1. When the internal RC is not selected, it is stopped so as to save power consumption.
2. When the internal RC is selected, the AWU RC is turned on by hardware when entering Auto Wake-Up from Halt mode.

3. When the external clock is selected, the AWU RC oscillator is always on.

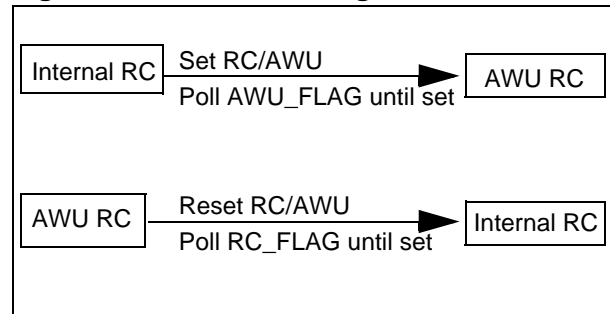
Figure 13. Clock Switching

7.2 REGISTER DESCRIPTION

MAIN CLOCK CONTROL/STATUS REGISTER (MCCSR)

Read / Write

Reset Value: 0000 0000 (00h)

| | | | | | | | |
|---|---|---|---|---|---|-----|-----|
| 7 | | | | | | | 0 |
| 0 | 0 | 0 | 0 | 0 | 0 | MCO | SMS |

Bits 7:2 = Reserved, must be kept cleared.

Bit 1 = MCO Main Clock Out enable

This bit is read/write by software and cleared by hardware after a reset. This bit allows to enable the MCO output clock.

0: MCO clock disabled, I/O port free for general purpose I/O.

1: MCO clock enabled.

Bit 0 = **SMS** Slow Mode select

This bit is read/write by software and cleared by hardware after a reset. This bit selects the input clock f_{OSC} or $f_{OSC}/32$.

0: Normal mode ($f_{CPU} = f_{OSC}$)

1: Slow mode ($f_{CPU} = f_{OSC}/32$)

RC CONTROL REGISTER (RCCR)

Read / Write

Reset Value: 1111 1111 (FFh)

| | | | | | | | |
|-----|-----|-----|-----|-----|-----|-----|-----|
| 7 | | | | | | | 0 |
| CR9 | CR8 | CR7 | CR6 | CR5 | CR4 | CR3 | CR2 |

Bits 7:0 = **CR[9:2]** RC Oscillator Frequency Adjustment Bits

These bits, as well as CR[1:0] bits in the SICSR register must be written immediately after reset to adjust the RC oscillator frequency and to obtain the required accuracy. The application can store the correct value for each voltage range in Flash memory and write it to this register at start-up.

00h = maximum available frequency

FFh = lowest available frequency

Note: To tune the oscillator, write a series of different values in the register until the correct frequency is reached. The fastest method is to use a dichotomy starting with 80h.

SYSTEM INTEGRITY (SI) CONTROL/STATUS REGISTER (SICSR)

Read/Write

Reset Value: 0000 0x00 (0xh)

| | | | | | | | |
|---|-----|-----|---|---|-------|------|-------|
| 7 | | | | | | | 0 |
| 0 | CR1 | CR0 | 0 | 0 | LVDRF | AVDF | AVDIE |

Bit 7 = Reserved, must be kept cleared.

Bits 6:5 = **CR[1:0]** RC Oscillator Frequency Adjustment bits

These bits, as well as CR[9:2] bits in the RCCR register must be written immediately after reset to adjust the RC oscillator frequency and to obtain the required accuracy. Refer to [section 7.1 on page 22](#).

Bits 4:3 = Reserved, must be kept cleared.

Bits 2:0 = System Integrity bits. Refer to [Section 8.4 SYSTEM INTEGRITY MANAGEMENT \(SI\)](#).

REGISTER DESCRIPTION (Cont'd)

AVD THRESHOLD SELECTION REGISTER
(AVDTHCR)

Read/Write

Reset Value: 0000 0011 (03h)

| | | | | | | | |
|-----|-----|-----|---|---|---|------|------|
| 7 | | | | | | 0 | |
| CK2 | CK1 | CK0 | 0 | 0 | 0 | AVD1 | AVD0 |

Bits 7:5 = **CK[2:0]** internal RC Prescaler Selection
These bits are set by software and cleared by hardware after a reset. These bits select the prescaler of the internal RC oscillator. See [Figure 14 on page 26](#) and the following table and note:

Table 6. Internal RC Prescaler Selection bits

| CK2 | CK1 | CK0 | f_{osc} |
|--------|-----|-----|-------------|
| 0 | 0 | 1 | $f_{RC/2}$ |
| 0 | 1 | 0 | $f_{RC/4}$ |
| 0 | 1 | 1 | $f_{RC/8}$ |
| 1 | 0 | 0 | $f_{RC/16}$ |
| others | | | f_{RC} |

Note: If the internal RC is used with a supply operating range below 3.3V, a division ratio of at least 2 must be enabled in the RC prescaler.

Bits 4:2 = Reserved, must be kept cleared.

Bits 1:0 = AVD Threshold Selection bits. Refer to [Section 8.4 SYSTEM INTEGRITY MANAGEMENT \(SI\)](#).

Table 7. Clock Register Map and Reset Values

| Address (Hex.) | Register Label | 7 | 6 | 5 | 4 | 3 | 2 | 1 | 0 |
|----------------|-------------------------|----------|----------|----------|----------|---------------|--------------|-----------|-------------|
| 0038h | MCCSR Reset Value | - 0 | - 0 | - 0 | - 0 | - 0 | - 0 | MCO 0 | SMS 0 |
| 0039h | RCCR Reset Value | CR9 1 | CR8 1 | CR7 1 | CR6 1 | CR5 1 | CR4 1 | CR3 1 | CR2 1 |
| 003Ah | SICSR Reset Value | - 0 | CR1 0 | CR0 0 | - 0 | - 0 | LVDRF x | AVDF 0 | AVDIE 0 |
| 003Eh | AVDTHCR Reset Value | CK2 0 | CK1 0 | CK0 0 | - 0 | - 0 | - 0 | AVD1 1 | AVD2 1 |
| 003Fh | CKCNTCSR Reset Value | - 0 | - 0 | - 0 | - 0 | AWU_FLAG 1 | RC_FLAG 0 | - 0 | RC/AWU 1 |

CLOCK CONTROLLER CONTROL/STATUS REGISTER (CKCNTCSR)

Read/Write

Reset Value: 0000 1001 (09h)

| | | | | | | | |
|---|---|---|---|----------|---------|---|--------|
| 7 | | | | | | 0 | |
| 0 | 0 | 0 | 0 | AWU_FLAG | RC_FLAG | 0 | RC/AWU |

Bits 7:4 = Reserved, must be kept cleared.

Bit 3 = **AWU_FLAG** AWU Selection

This bit is set and cleared by hardware

0: No switch from AWU to RC requested

1: AWU clock activated and temporization completed

Bit 2 = **RC_FLAG** RC Selection

This bit is set and cleared by hardware

0: No switch from RC to AWU requested

1: RC clock activated and temporization completed

Bit 1 = Reserved, must be kept cleared.

Bit 0 = **RC/AWU** RC/AWU Selection

0: RC enabled

1: AWU enabled (default value)

SUPPLY, RESET AND CLOCK MANAGEMENT (Cont'd)

Figure 14. Clock Management Block Diagram

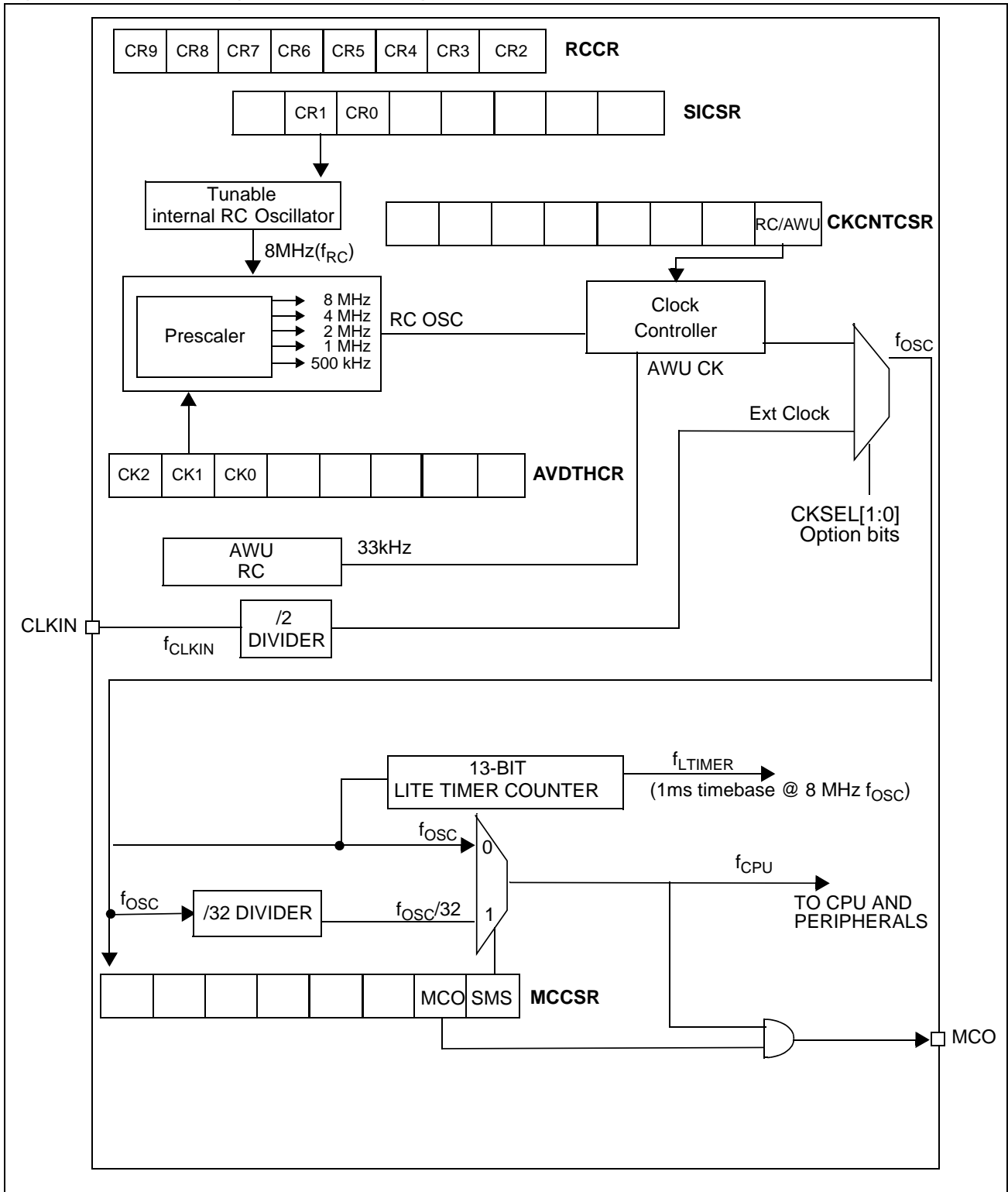

7.3 RESET SEQUENCE MANAGER (RSM)

7.3.1 Introduction

The reset sequence manager includes three RESET sources as shown in [Figure 16](#):

- External $\overline{\text{RESET}}$ source pulse
- Internal LVD RESET (Low Voltage Detection)
- Internal WATCHDOG RESET

Note: A reset can also be triggered following the detection of an illegal opcode or prebyte code. Refer to [Figure 16](#).

These sources act on the $\overline{\text{RESET}}$ pin and it is always kept low during the delay phase.

The RESET service routine vector is fixed at addresses FFFEh-FFFFh in the ST7 memory map.

The basic RESET sequence consists of 3 phases as shown in [Figure 15](#):

- Active Phase depending on the RESET source
- 256 or 512 CPU clock cycle delay (see table below)
- RESET vector fetch

Caution: When the ST7 is unprogrammed or fully erased, the Flash is blank and the RESET vector is not programmed. For this reason, it is recommended to keep the RESET pin in low state until programming mode is entered, in order to avoid unwanted behavior.

Figure 15. RESET Sequence Phases

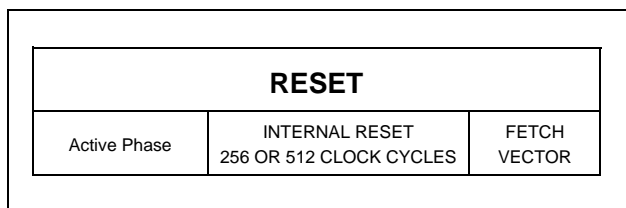

The 256 or 512 CPU clock cycle delay allows the oscillator to stabilise and ensures that recovery has taken place from the Reset state. The shorter or longer clock cycle delay is automatically selected depending on the clock source chosen by option byte after a reset or depending on the clock source selected before entering Halt mode or AWU from Halt mode:

Table 8. CPU clock cycle delay

| Clock source | CPU clock cycle delay |
|---|-----------------------|
| Internal RC oscillator | 512 |
| External clock (connected to CLKIN pin) | |
| AWURC | 256 |

The RESET vector fetch phase duration is 2 clock cycles.

Figure 16. Reset Block Diagram

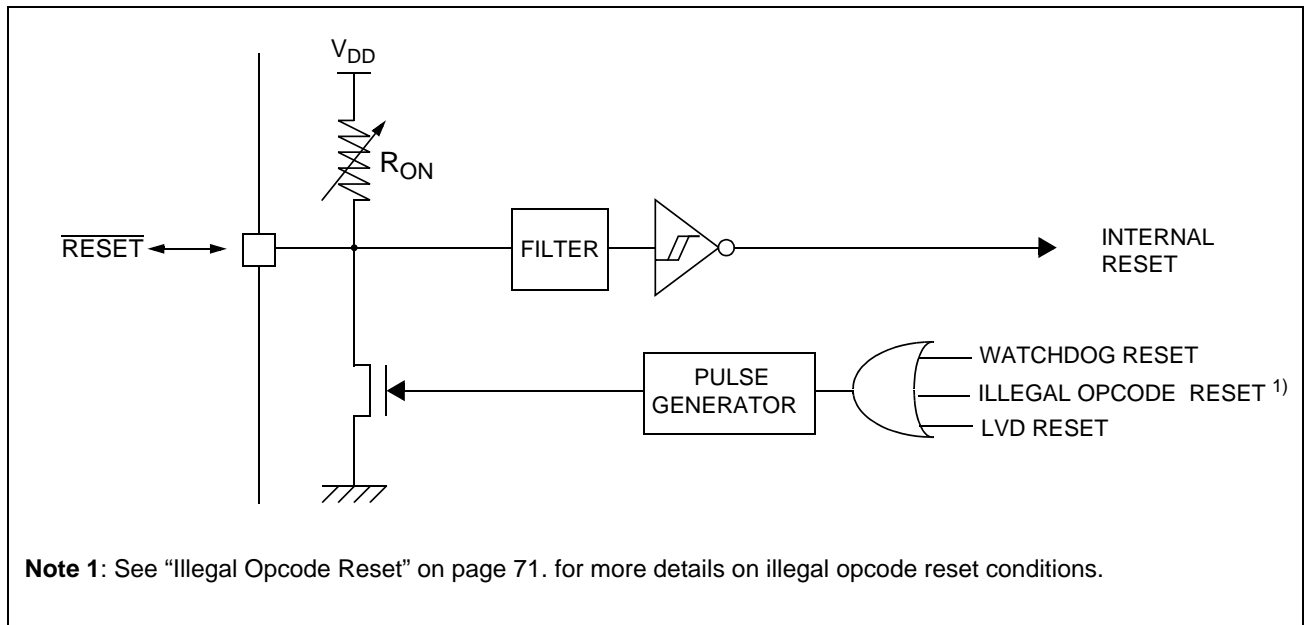

RESET SEQUENCE MANAGER (Cont'd)

7.3.2 Asynchronous External RESET pin

The RESET pin is both an input and an open-drain output with integrated R_{ON} weak pull-up resistor. This pull-up has no fixed value but varies in accordance with the input voltage. It can be pulled low by external circuitry to reset the device. See Electrical Characteristic section for more details.

A RESET signal originating from an external source must have a duration of at least t_{h(RSTL)in} in order to be recognized (see Figure 17). This detection is asynchronous and therefore the MCU can enter reset state even in HALT mode.

The RESET pin is an asynchronous signal which plays a major role in EMS performance. In a noisy environment, it is recommended to follow the guidelines mentioned in the electrical characteristics section.

7.3.3 External Power-On RESET

If the LVD is disabled by option byte, to start up the microcontroller correctly, the user must ensure by means of an external reset circuit that the reset signal is held low until V_{DD} is over the minimum level specified for the selected f_{CLKIN} frequency.

A proper reset signal for a slow rising V_{DD} supply can generally be provided by an external RC network connected to the RESET pin.

7.3.4 Internal Low Voltage Detector (LVD) RESET

Two different RESET sequences caused by the internal LVD circuitry can be distinguished:

- Power-On RESET
- Voltage Drop RESET

The device RESET pin acts as an output that is pulled low when V_{DD} < V_{IT+} (rising edge) or V_{DD} < V_{IT-} (falling edge) as shown in Figure 17.

The LVD filters spikes on V_{DD} larger than t_{g(VDD)} to avoid parasitic resets.

7.3.5 Internal Watchdog RESET

The RESET sequence generated by a internal Watchdog counter overflow is shown in Figure 17.

Starting from the Watchdog counter underflow, the device RESET pin acts as an output that is pulled low during at least t_{w(RSTL)out}.

Figure 17. RESET Sequences

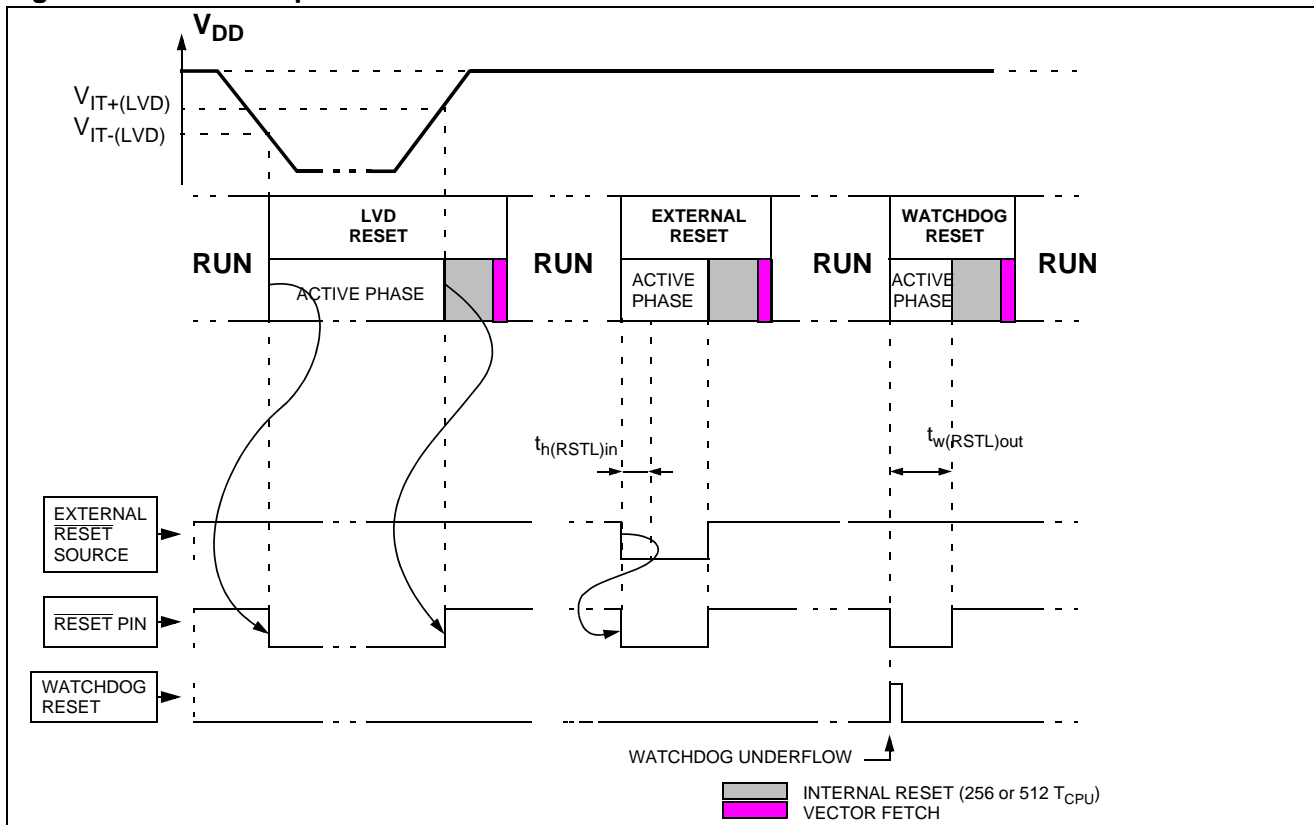

7.4 REGISTER DESCRIPTION

MULTIPLEXED IO RESET CONTROL REGISTER 1 (MUXCR1)

Read / Write once only

Reset Value: 0000 0000 (00h)

7 0

| | | | | | | | |
|------|------|------|------|------|------|-----|-----|
| MIR1 | MIR1 | MIR1 | MIR1 | MIR1 | MIR1 | MIR | MIR |
| 5 | 4 | 3 | 2 | 1 | 0 | 9 | 8 |

MULTIPLEXED IO RESET CONTROL REGISTER 0 (MUXCR0)

Read / Write once only

Reset Value: 0000 0000 (00h)

7 0

| | | | | | | | |
|------|------|------|------|------|------|------|------|
| MIR7 | MIR6 | MIR5 | MIR4 | MIR3 | MIR2 | MIR1 | MIR0 |
|------|------|------|------|------|------|------|------|

Bits 15:0 = **MIR[15:0]**

This 16-bit register is read/write by software but can be written only once between two reset events. It is cleared by hardware after a reset; When both MUXCR0 and MUXCR1 registers are at 00h, the multiplexed PA3/RESET pin will act as RESET. To configure this pin as output (Port A3), write 55h to MUXCR0 and AAh to MUXCR1.

These registers are one-time writable only.

– To configure PA3 as general purpose output:
After power-on / reset, the application program has to configure the I/O port by writing to these registers as described above. Once the pin is configured as an I/O output, it cannot be changed back to a reset pin by the application code.

– To configure PA3 as $\overline{\text{RESET}}$:
An internally generated reset (such as POR, LVD, WDG, illegal opcode) will clear the two registers and the pin will act again as a reset function. Otherwise, a power-down is required to put the pin back in reset configuration.

Table 9. Multiplexed IO Register Map and Reset Values

| Address (Hex.) | Register Label | 7 | 6 | 5 | 4 | 3 | 2 | 1 | 0 |
|----------------|-----------------------|------------|------------|------------|------------|------------|------------|-----------|-----------|
| 0047h | MUXCR0 Reset Value | MIR7 0 | MIR6 0 | MIR5 0 | MIR4 0 | MIR3 0 | MIR2 0 | MIR1 0 | MIR0 0 |
| 0048h | MUXCR1 Reset Value | MIR15 0 | MIR14 0 | MIR13 0 | MIR12 0 | MIR11 0 | MIR10 0 | MIR9 0 | MIR8 0 |

8 INTERRUPTS

The ST7 core may be interrupted by one of two different methods: Maskable hardware interrupts as listed in the “interrupt mapping” table and a non-maskable software interrupt (TRAP). The Interrupt processing flowchart is shown in [Figure 18](#).

The maskable interrupts must be enabled by clearing the I bit in order to be serviced. However, disabled interrupts may be latched and processed when they are enabled (see external interrupts subsection).

Note: After reset, all interrupts are disabled.

When an interrupt has to be serviced:

- Normal processing is suspended at the end of the current instruction execution.
- The PC, X, A and CC registers are saved onto the stack.
- The I bit of the CC register is set to prevent additional interrupts.
- The PC is then loaded with the interrupt vector of the interrupt to service and the first instruction of the interrupt service routine is fetched (refer to the Interrupt Mapping table for vector addresses).

The interrupt service routine should finish with the IRET instruction which causes the contents of the saved registers to be recovered from the stack.

Note: As a consequence of the IRET instruction, the I bit is cleared and the main program resumes.

Priority Management

By default, a servicing interrupt cannot be interrupted because the I bit is set by hardware entering in interrupt routine.

In the case when several interrupts are simultaneously pending, an hardware priority defines which one will be serviced first (see the Interrupt Mapping table).

Interrupts and Low Power Mode

All interrupts allow the processor to leave the WAIT low power mode. Only external and specifically mentioned interrupts allow the processor to leave the HALT low power mode (refer to the “Exit from HALT” column in the Interrupt Mapping table).

8.1 NON MASKABLE SOFTWARE INTERRUPT

This interrupt is entered when the TRAP instruction is executed regardless of the state of the I bit. It is serviced according to the flowchart in [Figure 18](#).

8.2 EXTERNAL INTERRUPTS

External interrupt vectors can be loaded into the PC register if the corresponding external interrupt occurred and if the I bit is cleared. These interrupts allow the processor to leave the HALT low power mode.

The external interrupt polarity is selected through the miscellaneous register or interrupt register (if available).

An external interrupt triggered on edge will be latched and the interrupt request automatically cleared upon entering the interrupt service routine.

Caution: The type of sensitivity defined in the Miscellaneous or Interrupt register (if available) applies to the ei source. In case of a Nanded source (as described in the I/O ports section), a low level on an I/O pin, configured as input with interrupt, masks the interrupt request even in case of rising-edge sensitivity.

8.3 PERIPHERAL INTERRUPTS

Different peripheral interrupt flags in the status register are able to cause an interrupt when they are active if both:

- The I bit of the CC register is cleared.
- The corresponding enable bit is set in the control register.

If any of these two conditions is false, the interrupt is latched and thus remains pending.

Clearing an interrupt request is done by:

- Writing “0” to the corresponding bit in the status register or
- Access to the status register while the flag is set followed by a read or write of an associated register.

Note: The clearing sequence resets the internal latch. A pending interrupt (that is, waiting for being enabled) will therefore be lost if the clear sequence is executed.

INTERRUPTS (Cont'd)**EXTERNAL INTERRUPT CONTROL REGISTER 1 (EICR1)**

Read/Write

Reset Value: 0000 0000 (00h)

| | | | | | | | |
|---|---|------|------|------|------|------|------|
| 7 | | | | | | | 0 |
| 0 | 0 | IS21 | IS20 | IS11 | IS10 | IS01 | IS00 |

Bits 7:6 = Reserved

Bits 5:4 = **IS2[1:0]** *ei2 sensitivity*These bits define the interrupt sensitivity for ei2 according to [Table 11](#).Bits 3:2 = **IS1[1:0]** *ei1 sensitivity*These bits define the interrupt sensitivity for ei1 according to [Table 11](#).Bits 1:0 = **IS0[1:0]** *ei0 sensitivity*These bits define the interrupt sensitivity for ei0 according to [Table 11](#).**Notes:**

1. These 8 bits can be written only when the I bit in the CC register is set.
2. Changing the sensitivity of a particular external interrupt clears this pending interrupt. This can be used to clear unwanted pending interrupts. Refer to section "External interrupt function" on page 47.
3. Whatever the sensitivity configuration, ei2 cannot exit the MCU from HALT, ACTIVE-HALT and AWUFH modes when a falling edge occurs.

Table 11. Interrupt Sensitivity Bits

| ISx1 | ISx0 | External Interrupt Sensitivity |
|------|------|--------------------------------|
| 0 | 0 | Falling edge & low level |
| 0 | 1 | Rising edge only |
| 1 | 0 | Falling edge only |
| 1 | 1 | Rising and falling edge |

EXTERNAL INTERRUPT CONTROL REGISTER 2 (EICR2)

Read/Write

Reset Value: 0000 0000 (00h)

| | | | | | | | | | |
|---|---|---|---|------|------|------|------|--|---|
| 7 | | | | | | | | | 0 |
| 0 | 0 | 0 | 0 | IS41 | IS40 | IS31 | IS30 | | |

Bits 7:4 = Reserved

Bits 3:2 = **IS4[1:0]** *ei4 sensitivity*These bits define the interrupt sensitivity for ei1 according to [Table 11](#).Bits 1:0 = **IS3[1:0]** *ei3 sensitivity*These bits define the interrupt sensitivity for ei0 according to [Table 11](#).**Notes:**

1. These 8 bits can be written only when the I bit in the CC register is set.
2. Changing the sensitivity of a particular external interrupt clears this pending interrupt. This can be used to clear unwanted pending interrupts. Refer to section "External interrupt function" on page 47.
3. IS4[1:0] = 01 is the only safe configuration to avoid spurious interrupt in HALT and AWUFH modes.

8.4 SYSTEM INTEGRITY MANAGEMENT (SI)

The System Integrity Management block contains the Low voltage Detector (LVD) and Auxiliary Voltage Detector (AVD) functions. It is managed by the SICSR register.

Note: A reset can also be triggered following the detection of an illegal opcode or prebyte code. Refer to [section 12.2.1 on page 71](#) for further details.

8.4.1 Low Voltage Detector (LVD)

The Low Voltage Detector function (LVD) generates a static reset when the V_{DD} supply voltage is below a $V_{IT-(LVD)}$ reference value. This means that it secures the power-up as well as the power-down keeping the ST7 in reset.

The $V_{IT-(LVD)}$ reference value for a voltage drop is lower than the $V_{IT+(LVD)}$ reference value for power-on in order to avoid a parasitic reset when the MCU starts running and sinks current on the supply (hysteresis).

The LVD Reset circuitry generates a reset when V_{DD} is below:

- $V_{IT+(LVD)}$ when V_{DD} is rising
- $V_{IT-(LVD)}$ when V_{DD} is falling

The LVD function is illustrated in [Figure 19](#).

The voltage threshold can be configured by option byte to be low, medium or high. See [section 15.1 on page 105](#).

Provided the minimum V_{DD} value (guaranteed for the oscillator frequency) is above $V_{IT-(LVD)}$, the MCU can only be in two modes:

- under full software control
- in static safe reset

Figure 19. Low Voltage Detector vs Reset

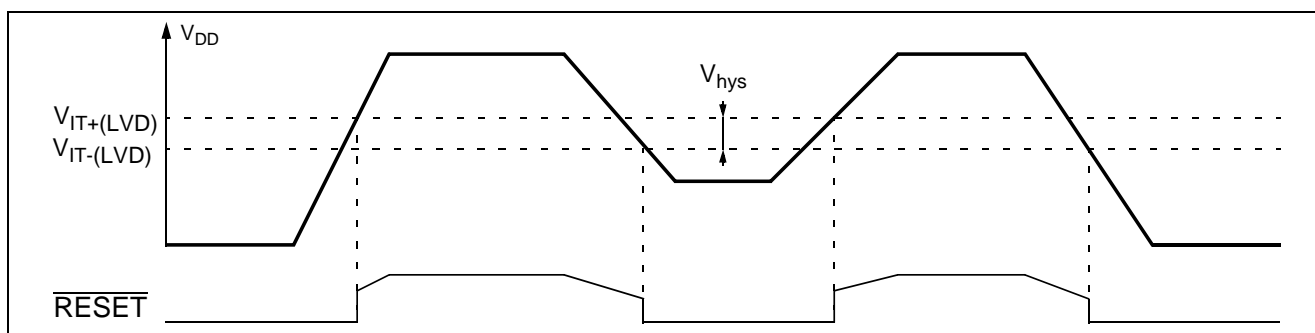

In these conditions, secure operation is always ensured for the application without the need for external reset hardware.

During a Low Voltage Detector Reset, the \overline{RESET} pin is held low, thus permitting the MCU to reset other devices.

Notes:

Use of LVD with capacitive power supply: with this type of power supply, if power cuts occur in the application, it is recommended to pull V_{DD} down to 0V to ensure optimum restart conditions. Refer to circuit example in [Figure 67 on page 97](#) and note 4.

The LVD is an optional function which can be selected by option byte. See [section 15.1 on page 105](#). It allows the device to be used without any external RESET circuitry. If the LVD is disabled, an external circuitry must be used to ensure a proper power-on reset.

It is recommended to make sure that the V_{DD} supply voltage rises monotonously when the device is exiting from Reset, to ensure the application functions properly.

Make sure the right combination of LVD and AVD thresholds is used as LVD and AVD levels are not correlated. Refer to [section 13.3.2 on page 77](#) and [section 13.3.3 on page 77](#) for more details.

Caution: If an LVD reset occurs after a watchdog reset has occurred, the LVD will take priority and will clear the watchdog flag.

SYSTEM INTEGRITY MANAGEMENT (Cont'd)

Figure 20. Reset and Supply Management Block Diagram

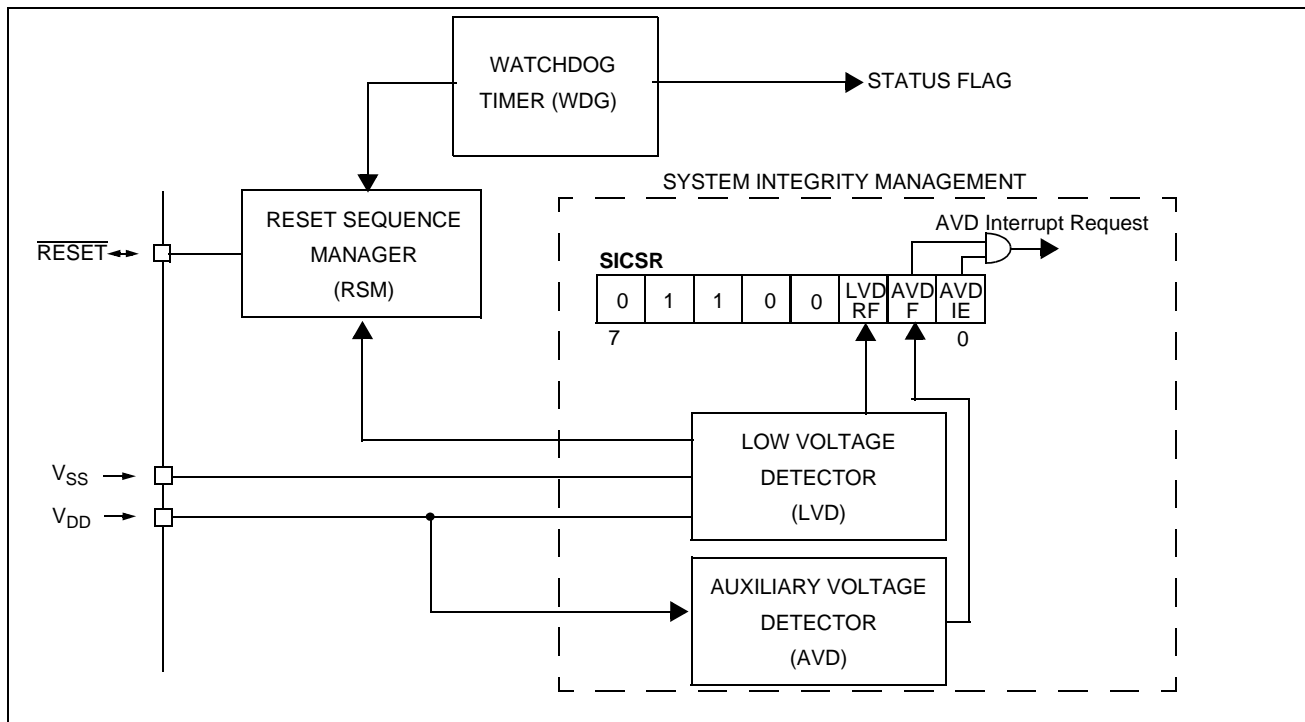

8.4.2 Auxiliary Voltage Detector (AVD)

The Voltage Detector function (AVD) is based on an analog comparison between a $V_{IT-(AVD)}$ and $V_{IT+(AVD)}$ reference value and the V_{DD} main supply voltage (V_{AVD}). The $V_{IT-(AVD)}$ reference value for falling voltage is lower than the $V_{IT+(AVD)}$ reference value for rising voltage in order to avoid parasitic detection (hysteresis).

The output of the AVD comparator is directly readable by the application software through a real time status bit (AVDF) in the SICSR register. This bit is read only.

8.4.2.1 Monitoring the V_{DD} Main Supply.

The AVD threshold is selected by the AVD[1:0] bits in the AVDTHCR register.

If the AVD interrupt is enabled, an interrupt is generated when the voltage crosses the $V_{IT+(AVD)}$ or $V_{IT-(AVD)}$ threshold (AVDF bit is set).

In the case of a drop in voltage, the AVD interrupt acts as an early warning, allowing software to shut down safely before the LVD resets the microcontroller. See [Figure 21](#).

The interrupt on the rising edge is used to inform the application that the V_{DD} warning state is over

Note: Make sure the right combination of LVD and AVD thresholds is used as LVD and AVD levels are not correlated. Refer to [section 13.3.2 on page 77](#) and [section 13.3.3 on page 77](#) for more details.

SYSTEM INTEGRITY MANAGEMENT (Cont'd)

Figure 21. Using the AVD to Monitor V_{DD}

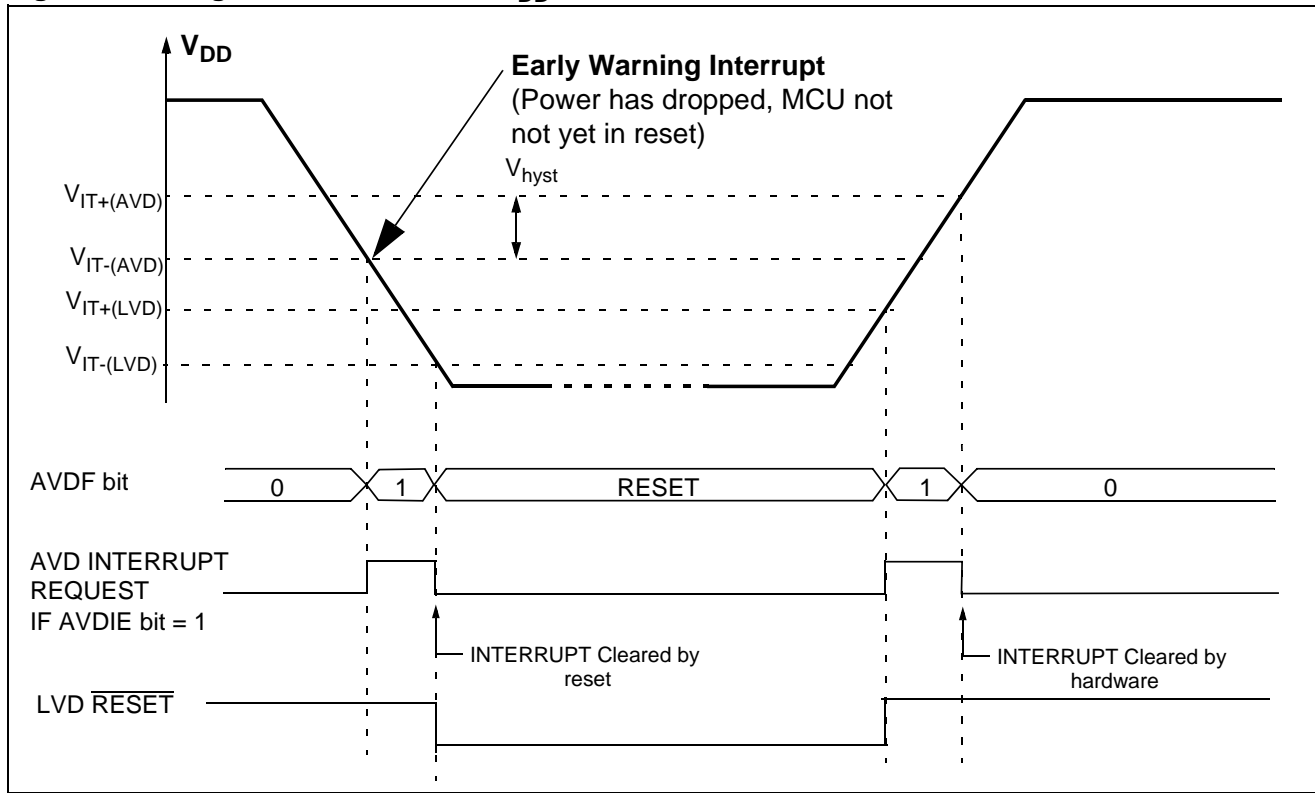

8.4.3 Low Power Modes

| Mode | Description |
|------|---|
| WAIT | No effect on SI. AVD interrupts cause the device to exit from Wait mode. |
| HALT | The SICSR register is frozen. The AVD remains active but the AVD interrupt cannot be used to exit from Halt mode. |

8.4.3.1 Interrupts

The AVD interrupt event generates an interrupt if the corresponding Enable Control Bit (AVDIE) is set and the interrupt mask in the CC register is reset (RIM instruction).

| Interrupt Event | Event Flag | Enable Control Bit | Exit from Wait | Exit from Halt |
|-----------------|------------|--------------------|----------------|----------------|
| AVD event | AVDF | AVDIE | Yes | No |

SYSTEM INTEGRITY MANAGEMENT (Cont'd)

8.4.4 Register Description

SYSTEM INTEGRITY (SI) CONTROL/STATUS REGISTER (SICSR)

Read/Write

Reset Value: 0000 0x00 (0xh)

| | | | | | | | |
|---|-----|-----|---|---|-------|------|-------|
| 7 | | | | | | | 0 |
| 0 | CR1 | CR0 | 0 | 0 | LVDRF | AVDF | AVDIE |

Bit 7 = Reserved, must be kept cleared.

Bits 6:5 = **CR[1:0]** RC Oscillator Frequency Adjustment bits

These bits, as well as CR[9:2] bits in the RCCR register must be written immediately after reset to adjust the RC oscillator frequency and to obtain the required accuracy. Refer to [section 7.1 on page 22](#).

Bits 4:3 = Reserved, must be kept cleared.

Bit 2 = **LVDRF** LVD reset flag

This bit indicates that the last Reset was generated by the LVD block. It is set by hardware (LVD reset) and cleared when read. See WDGRF flag description in [Section 11.1](#) for more details. When the LVD is disabled by OPTION BYTE, the LVDRF bit value is undefined.

Note: If the selected clock source is one of the two internal ones, and if V_{DD} remains below the selected LVD threshold during less than T_{AWU_RC} (33 μ s typ.), the LVDRF flag cannot be set even if the device is reset by the LVD. If the selected clock source is the external clock (CLKIN), the flag is never set if the reset occurs during Halt mode. In run mode the flag is set only if f_{CLKIN} is greater than 10MHz.

Bit 1 = **AVDF** Voltage Detector flag

This read-only bit is set and cleared by hardware. If the AVDIE bit is set, an interrupt request is generated when the AVDF bit is set. Refer to [Figure 21](#) for additional details

0: V_{DD} over AVD threshold1: V_{DD} under AVD thresholdBit 0 = **AVDIE** Voltage Detector interrupt enable

This bit is set and cleared by software. It enables an interrupt to be generated when the AVDF flag is set. The pending interrupt information is automatically cleared when software enters the AVD interrupt routine.

0: AVD interrupt disabled

1: AVD interrupt enabled

AVD THRESHOLD SELECTION REGISTER (AVDTHCR)

Read/Write

Reset Value: 0000 0011 (03h)

| | | | | | | | |
|-----|-----|-----|---|---|---|------|------|
| 7 | | | | | | 0 | |
| CK2 | CK1 | CK0 | 0 | 0 | 0 | AVD1 | AVD0 |

Bits 7:5 = **CK[2:0]** internal RC Prescaler Selection
Refer to [Section 7.1 INTERNAL RC OSCILLATOR ADJUSTMENT](#) on [page 22](#).

Bits 4:2 = Reserved, must be kept cleared.

Bits 1:0 = **AVD[1:0]** AVD Threshold Selection

These bits are set and cleared by software and set by hardware after a reset. They select the AVD threshold.

Table 12. AVD Threshold Selection bits

| AVD1 | AVD0 | Functionality |
|------|------|---------------|
| 0 | 0 | Low |
| 0 | 1 | Medium |
| 1 | 0 | High |
| 1 | 1 | AVD off |

Application notes

The LVDRF flag is not cleared when another RESET type occurs (external or watchdog), the LVDRF flag remains set to keep trace of the original failure.

In this case, a watchdog reset can be detected by software while an external reset can not.

REGISTER DESCRIPTION (Cont'd)

Table 13. System Integrity Register Map and Reset Values

| Address (Hex.) | Register Label | 7 | 6 | 5 | 4 | 3 | 2 | 1 | 0 |
|----------------|------------------------|----------|----------|----------|---|---|------------|-----------|------------|
| 003Ah | SICSR Reset Value | 0 | 1 | 1 | 0 | 0 | LVDRF x | AVDF 0 | AVDIE 0 |
| 003Eh | AVDTHCR Reset Value | CK2 0 | CK1 0 | CK0 0 | 0 | 0 | 0 | AVD1 1 | AVD2 1 |

9 POWER SAVING MODES

9.1 INTRODUCTION

To give a large measure of flexibility to the application in terms of power consumption, four main power saving modes are implemented in the ST7 (see Figure 22):

- Slow
- Wait (and Slow-Wait)
- Active Halt
- Auto Wake up From Halt (AWUFH)
- Halt

After a RESET the normal operating mode is selected by default (RUN mode). This mode drives the device (CPU and embedded peripherals) by means of a master clock which is based on the main oscillator frequency (f_{OSC}).

From RUN mode, the different power saving modes may be selected by setting the relevant register bits or by calling the specific ST7 software instruction whose action depends on the oscillator status.

Figure 22. Power Saving Mode Transitions

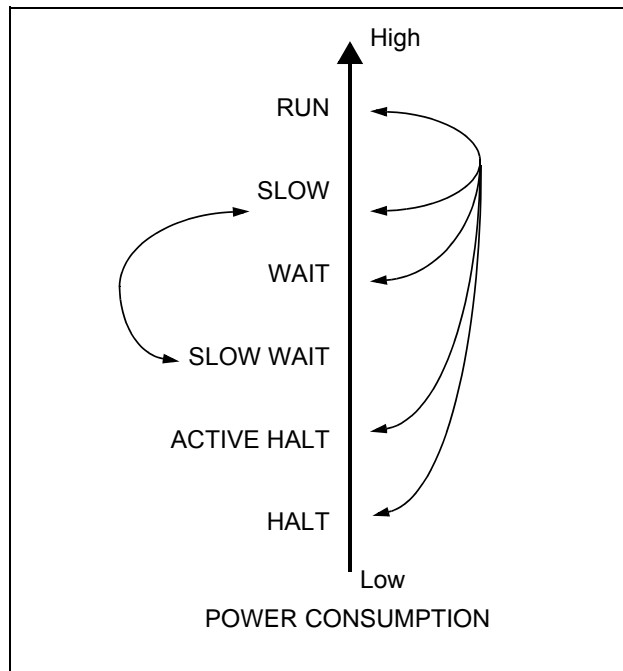

9.2 SLOW MODE

This mode has two targets:

- To reduce power consumption by decreasing the internal clock in the device,
- To adapt the internal clock frequency (f_{CPU}) to the available supply voltage.

SLOW mode is controlled by the SMS bit in the MCCR register which enables or disables Slow mode.

In this mode, the oscillator frequency is divided by 32. The CPU and peripherals are clocked at this lower frequency.

Notes:

SLOW-WAIT mode is activated when entering WAIT mode while the device is already in SLOW mode.

Figure 23. SLOW Mode Clock Transition

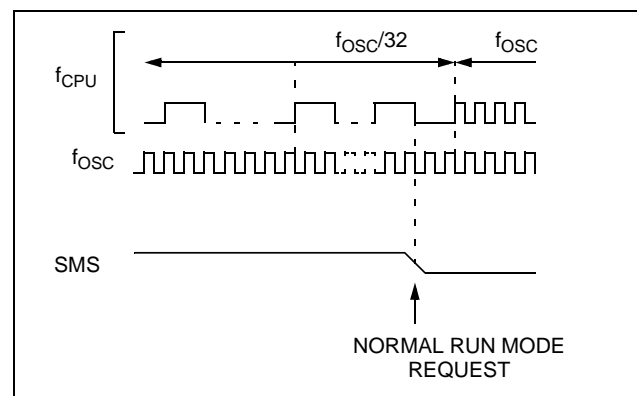

POWER SAVING MODES (Cont'd)

9.3 WAIT MODE

WAIT mode places the MCU in a low power consumption mode by stopping the CPU.

This power saving mode is selected by calling the 'WFI' instruction.

All peripherals remain active. During WAIT mode, the I bit of the CC register is cleared, to enable all interrupts. All other registers and memory remain unchanged. The MCU remains in WAIT mode until an interrupt or RESET occurs, whereupon the Program Counter branches to the starting address of the interrupt or Reset service routine.

The MCU will remain in WAIT mode until a Reset or an Interrupt occurs, causing it to wake up.

Refer to [Figure 24](#).

Figure 24. WAIT Mode Flow-chart

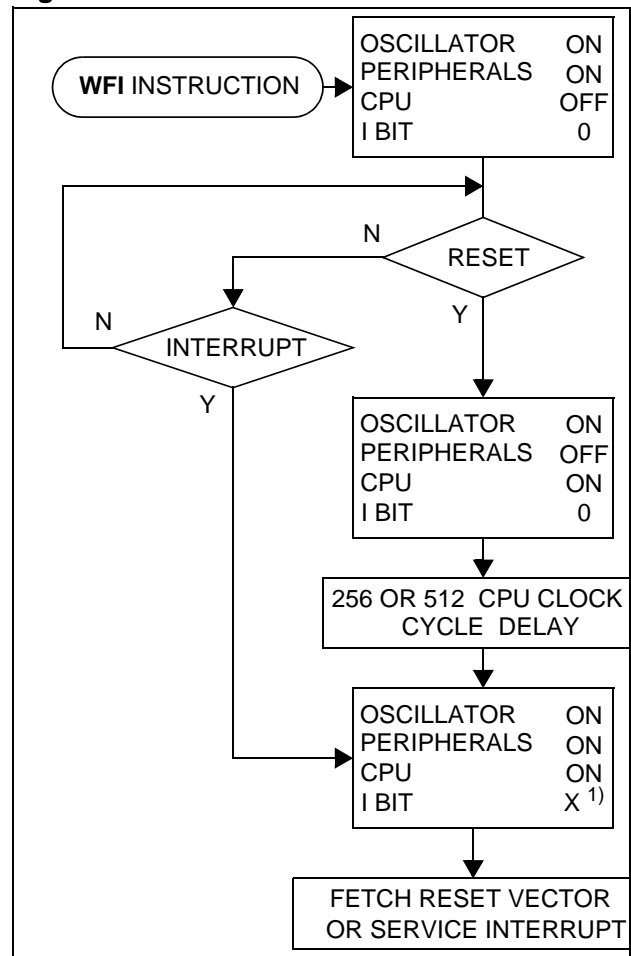
**Note:**

1. Before servicing an interrupt, the CC register is pushed on the stack. The I bit of the CC register is set during the interrupt routine and cleared when the CC register is popped.

POWER SAVING MODES (Cont'd)

9.4 ACTIVE-HALT AND HALT MODES

ACTIVE-HALT and HALT modes are the two lowest power consumption modes of the MCU. They are both entered by executing the 'HALT' instruction. The decision to enter either in ACTIVE-HALT or HALT mode is given by the LTCSR/ATCSR register status as shown in the following table:

| LTCSR TBIE bit | ATCSR OVFI bit | ATCSR CK1 bit | ATCSR CK0 bit | Meaning |
|----------------|----------------|---------------|---------------|---------------------------|
| 0 | x | x | 0 | ACTIVE-HALT mode disabled |
| 0 | 0 | x | x | |
| 0 | 1 | 1 | 1 | |
| 1 | x | x | x | ACTIVE-HALT mode enabled |
| x | 1 | 0 | 1 | |

9.4.1 ACTIVE-HALT MODE

ACTIVE-HALT mode is the lowest power consumption mode of the MCU with a real time clock available. It is entered by executing the 'HALT' instruction when active halt mode is enabled.

The MCU can exit ACTIVE-HALT mode on reception of a Lite Timer / AT Timer interrupt or a RESET.

- When exiting ACTIVE-HALT mode by means of a RESET, a 256 or 512 CPU cycle delay occurs. After the start up delay, the CPU resumes operation by fetching the reset vector which woke it up (see Figure 26).
- When exiting ACTIVE-HALT mode by means of an interrupt, the CPU immediately resumes operation by servicing the interrupt vector which woke it up (see Figure 26).

When entering ACTIVE-HALT mode, the I bit in the CC register is cleared to enable interrupts. Therefore, if an interrupt is pending, the MCU wakes up immediately.

In ACTIVE-HALT mode, only the main oscillator and the selected timer counter (LT/AT) are running to keep a wake-up time base. All other peripherals are not clocked except those which get their clock supply from another clock generator (such as external or auxiliary oscillator).

Caution: As soon as ACTIVE-HALT is enabled, executing a HALT instruction while the Watchdog is active does not generate a RESET if the WDGHALT bit is reset.

This means that the device cannot spend more than a defined delay in this power saving mode.

Figure 25. ACTIVE-HALT Timing Overview

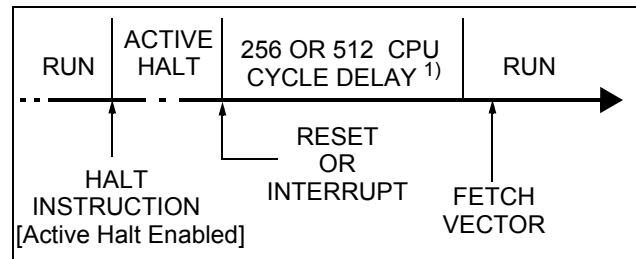
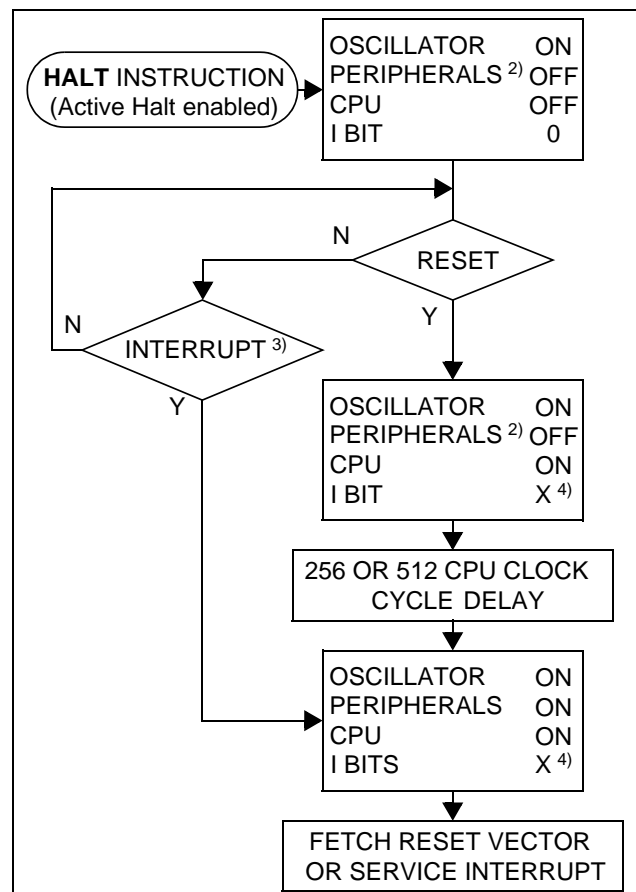

Figure 26. ACTIVE-HALT Mode Flow-chart



Notes:

1. This delay occurs only if the MCU exits ACTIVE-HALT mode by means of a RESET.
2. Peripherals clocked with an external clock source can still be active.
3. Only the Lite Timer RTC and AT Timer interrupts can exit the MCU from ACTIVE-HALT mode.
4. Before servicing an interrupt, the CC register is pushed on the stack. The I bit of the CC register is set during the interrupt routine and cleared when the CC register is popped.

POWER SAVING MODES (Cont'd)

9.4.2 HALT MODE

The HALT mode is the lowest power consumption mode of the MCU. It is entered by executing the 'HALT' instruction when active halt mode is disabled.

The MCU can exit HALT mode on reception of either a specific interrupt (see Table 10, "Interrupt mapping," on page 32) or a RESET. When exiting HALT mode by means of a RESET or an interrupt, the main oscillator is immediately turned on and the 256 or 512 CPU cycle delay is used to stabilize it. After the start up delay, the CPU resumes operation by servicing the interrupt or by fetching the reset vector which woke it up (see Figure 28).

When entering HALT mode, the I bit in the CC register is forced to 0 to enable interrupts. Therefore, if an interrupt is pending, the MCU wakes immediately.

In HALT mode, the main oscillator is turned off causing all internal processing to be stopped, including the operation of the on-chip peripherals. All peripherals are not clocked except the ones which get their clock supply from another clock generator (such as an external or auxiliary oscillator).

The compatibility of Watchdog operation with HALT mode is configured by the "WDGHALT" option bit of the option byte. The HALT instruction when executed while the Watchdog system is enabled, can generate a Watchdog RESET (see section 15.1 on page 105 for more details).

Figure 27. HALT Timing Overview

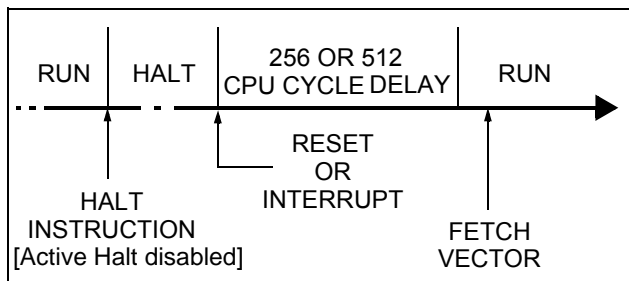
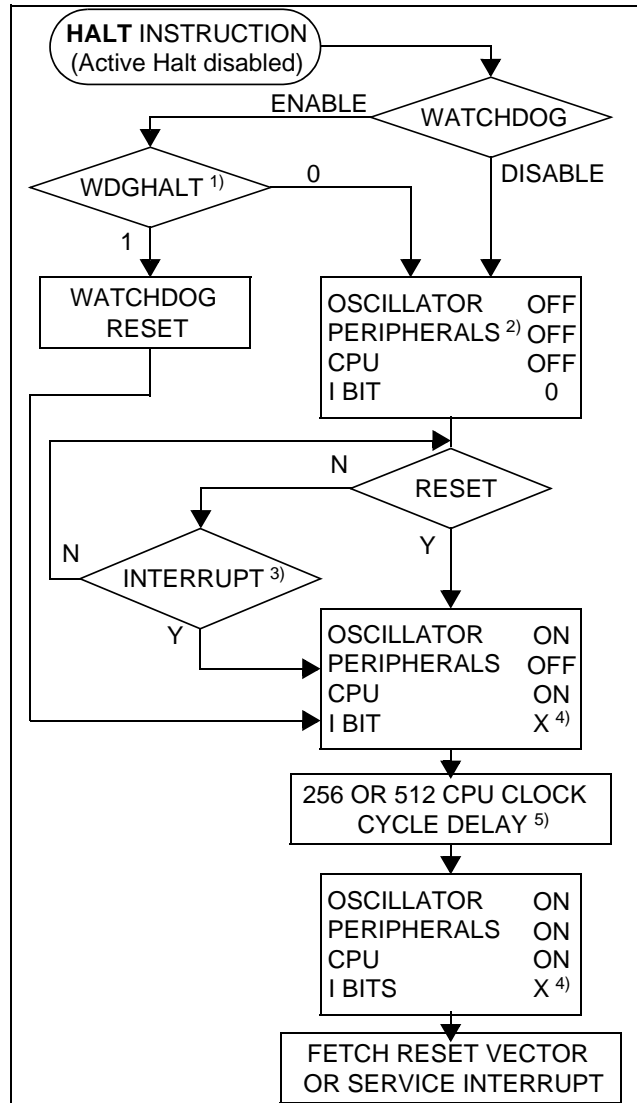

Figure 28. HALT Mode Flow-chart



Notes:

1. WDGHALT is an option bit. See option byte section for more details.
2. Peripheral clocked with an external clock source can still be active.
3. Only some specific interrupts can exit the MCU from HALT mode (such as external interrupt). Refer to Table 10, "Interrupt mapping," on page 32 for more details.
4. Before servicing an interrupt, the CC register is pushed on the stack. The I bit of the CC register is set during the interrupt routine and cleared when the CC register is popped.
5. The CPU clock must be switched to 1MHz (RC/8) or AWU RC before entering HALT mode.

POWER SAVING MODES (Cont'd)

9.4.2.1 HALT Mode Recommendations

- Make sure that an external event is available to wake up the microcontroller from Halt mode.
- When using an external interrupt to wake up the microcontroller, reinitialize the corresponding I/O as “Input Pull-up with Interrupt” before executing the HALT instruction. The main reason for this is that the I/O may be wrongly configured due to external interference or by an unforeseen logical condition.
- For the same reason, reinitialize the level sensitivity of each external interrupt as a precautionary measure.
- The opcode for the HALT instruction is 0x8E. To avoid an unexpected HALT instruction due to a program counter failure, it is advised to clear all occurrences of the data value 0x8E from memory. For example, avoid defining a constant in ROM with the value 0x8E.
- As the HALT instruction clears the I bit in the CC register to allow interrupts, the user may choose to clear all pending interrupt bits before executing the HALT instruction. This avoids entering other peripheral interrupt routines after executing the external interrupt routine corresponding to the wake-up event (reset or external interrupt).

9.5 AUTO WAKE UP FROM HALT MODE

Auto Wake Up From Halt (AWUFH) mode is similar to Halt mode with the addition of a specific internal RC oscillator for wake-up (Auto Wake-Up from Halt oscillator) which replaces the main clock which was active before entering HALT mode. Compared to ACTIVE-HALT mode, AWUFH has lower power consumption (the main clock is not kept running), but there is no accurate realtime clock available.

It is entered by executing the HALT instruction when the AWUEN bit in the AWUCSR register has been set.

Figure 29. AWUFH Mode Block Diagram

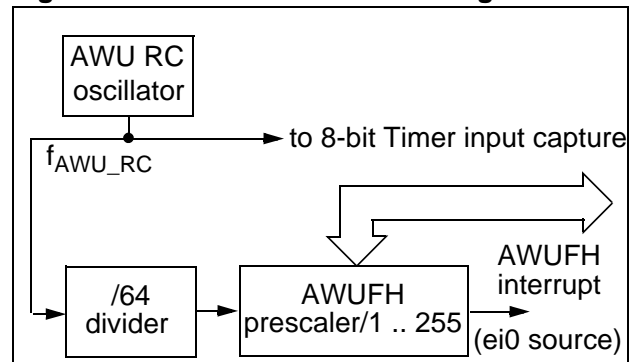

As soon as HALT mode is entered, and if the AWUEN bit has been set in the AWUCSR register, the AWU RC oscillator provides a clock signal (f_{AWU_RC}). Its frequency is divided by a fixed divider and a programmable prescaler controlled by the AWUPR register. The output of this prescaler provides the delay time. When the delay has elapsed, the following actions are performed:

- the AWUF flag is set by hardware,
- an interrupt wakes-up the MCU from Halt mode,
- the main oscillator is immediately turned on and the 256 or 512 CPU cycle delay is used to stabilize it.

After this start-up delay, the CPU resumes operation by servicing the AWUFH interrupt. The AWU flag and its associated interrupt are cleared by software reading the AWUCSR register.

To compensate for any frequency dispersion of the AWU RC oscillator, it can be calibrated by measuring the clock frequency f_{AWU_RC} and then calculating the right prescaler value. Measurement mode is enabled by setting the AWUM bit in the AWUCSR register in Run mode. This connects f_{AWU_RC} to the input capture of the 8-bit lite timer, allowing the f_{AWU_RC} to be measured using the main oscillator clock as a reference timebase.

POWER SAVING MODES (Cont'd)

Similarities with Halt mode

The following AWUFH mode behaviour is the same as normal Halt mode:

- The MCU can exit AWUFH mode by means of any interrupt with exit from Halt capability or a reset (see [Section 9.4 ACTIVE-HALT AND HALT MODES](#)).
- When entering AWUFH mode, the I bit in the CC register is forced to 0 to enable interrupts. Therefore, if an interrupt is pending, the MCU wakes up immediately.

- In AWUFH mode, the main oscillator is turned off causing all internal processing to be stopped, including the operation of the on-chip peripherals. None of the peripherals are clocked except those which get their clock supply from another clock generator (such as an external or auxiliary oscillator like the AWU oscillator).
- The compatibility of watchdog operation with AWUFH mode is configured by the WDGHALT option bit in the option byte. Depending on this setting, the HALT instruction when executed while the watchdog system is enabled, can generate a watchdog RESET.

Figure 30. AWUF Halt Timing Diagram

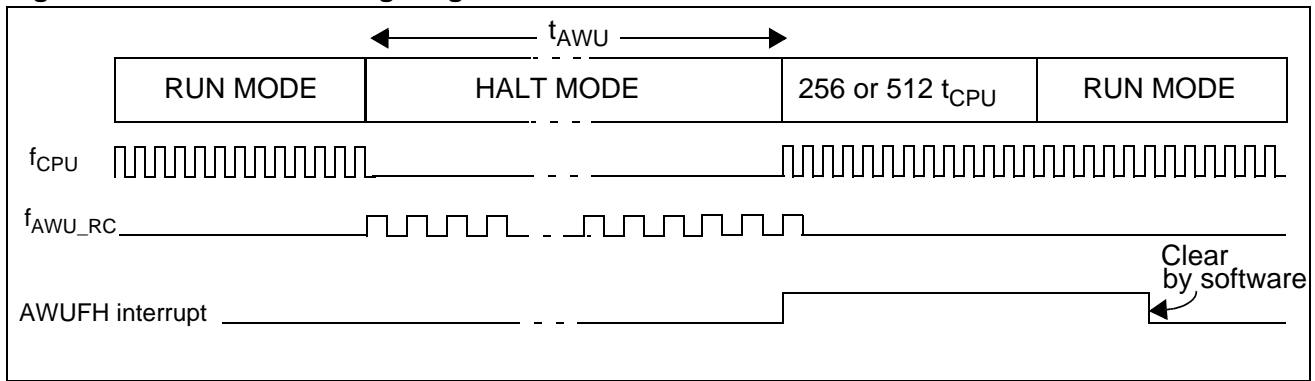
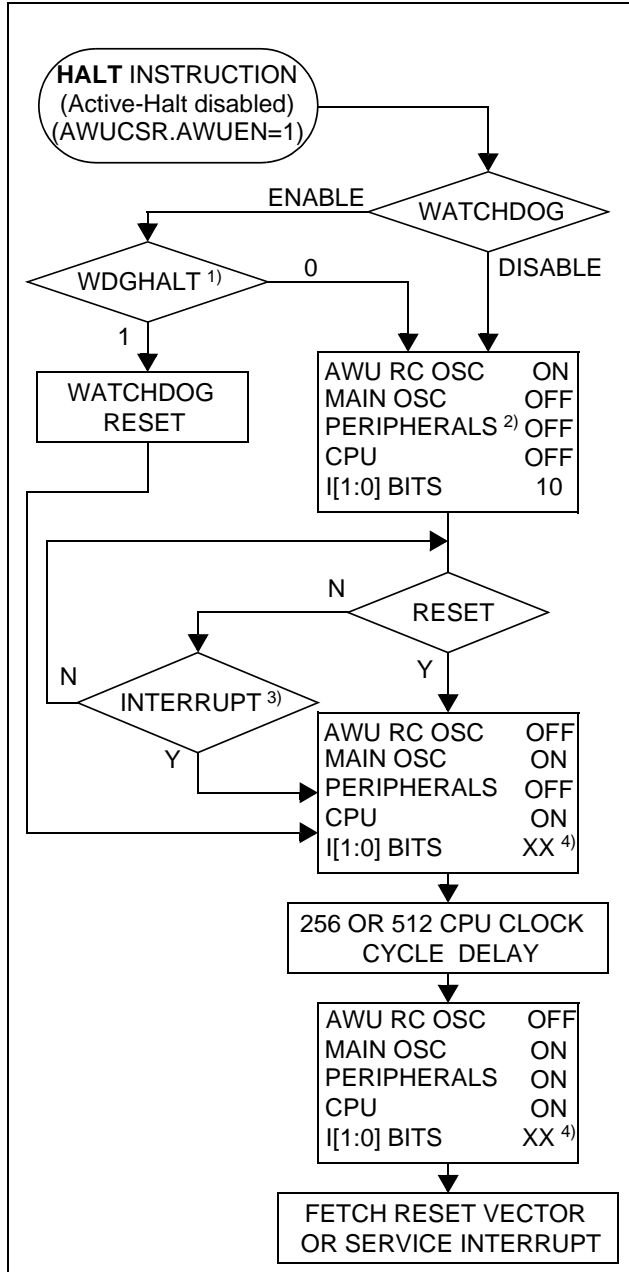

Figure 31. AWUFH Mode Flow-chart



Notes:

1. WDGHALT is an option bit. See option byte section for more details.
2. Peripheral clocked with an external clock source can still be active.
3. Only an AWUFH interrupt and some specific interrupts can exit the MCU from HALT mode (such as external interrupt). Refer to Table 10, "Interrupt mapping," on page 32 for more details.
4. Before servicing an interrupt, the CC register is pushed on the stack. The I[1:0] bits of the CC register are set to the current software priority level of the interrupt routine and recovered when the CC register is popped.

POWER SAVING MODES (Cont'd)

9.5.1 Register Description

AWUFH CONTROL/STATUS REGISTER (AWUCSR)

Read/Write

Reset Value: 0000 0000 (00h)

| | | | | | | | |
|---|---|---|---|---|----------|----------|-----------|
| 7 | | | | | | | 0 |
| 0 | 0 | 0 | 0 | 0 | AWU F | AWU M | AWU EN |

Bits 7:3 = Reserved.

Bit 2= AWUF Auto Wake Up Flag

This bit is set by hardware when the AWU module generates an interrupt and cleared by software on reading AWUCSR. Writing to this bit does not change its value.

0: No AWU interrupt occurred

1: AWU interrupt occurred

Bit 1= AWUM Auto Wake Up Measurement

This bit enables the AWU RC oscillator and connects its output to the input capture of the 8-bit Lite timer. This allows the timer to be used to measure the AWU RC oscillator dispersion and then compensate this dispersion by providing the right value in the AWUPRE register.

0: Measurement disabled

1: Measurement enabled

Bit 0 = AWUEN Auto Wake Up From Halt Enabled

This bit enables the Auto Wake Up From Halt feature: once HALT mode is entered, the AWUFH wakes up the microcontroller after a time delay dependent on the AWU prescaler value. It is set and cleared by software.

0: AWUFH (Auto Wake Up From Halt) mode disabled

1: AWUFH (Auto Wake Up From Halt) mode enabled

Note: whatever the clock source, this bit should be set to enable the AWUFH mode once the HALT instruction has been executed.

Table 14. AWU Register Map and Reset Values

| Address (Hex.) | Register Label | 7 | 6 | 5 | 4 | 3 | 2 | 1 | 0 |
|----------------|------------------------------|---|---|---|---|---|------|------|-------|
| 0049h | AWUPR Reset Value | 1 | 1 | 1 | 1 | 1 | 1 | 1 | 1 |
| 004Ah | AWUCSR Reset Value | 0 | 0 | 0 | 0 | 0 | AWUF | AWUM | AWUEN |

AWUFH PRESCALER REGISTER (AWUPR)

Read/Write

Reset Value: 1111 1111 (FFh)

| | | | | | | | |
|------------|------------|------------|------------|------------|------------|------------|------------|
| 7 | | | | | | | 0 |
| AWU PR7 | AWU PR6 | AWU PR5 | AWU PR4 | AWU PR3 | AWU PR2 | AWU PR1 | AWU PR0 |

Bits 7:0= **AWUPR[7:0] Auto Wake Up Prescaler**
These 8 bits define the AWUPR Dividing factor (as explained below:

| AWUPR[7:0] | Dividing factor |
|------------|-----------------|
| 00h | Forbidden |
| 01h | 1 |
| ... | ... |
| FEh | 254 |
| FFh | 255 |

In AWU mode, the period that the MCU stays in Halt Mode (t_{AWU} in [Figure 30 on page 44](#)) is defined by

$$t_{AWU} = 64 \times AWUPR \times \frac{1}{f_{AWURC}} + t_{RCSTRT}$$

This prescaler register can be programmed to modify the time that the MCU stays in Halt mode before waking up automatically.

Note: If 00h is written to AWUPR, depending on the product, an interrupt is generated immediately after a HALT instruction, or the AWUPR remains unchanged.

10 I/O PORTS

10.1 INTRODUCTION

The I/O port offers different functional modes:

- transfer of data through digital inputs and outputs and for specific pins:
- external interrupt generation
- alternate signal input/output for the on-chip peripherals.

An I/O port contains up to 6 pins. Each pin (except PA3/RESET) can be programmed independently as digital input (with or without interrupt generation) or digital output.

10.2 FUNCTIONAL DESCRIPTION

Each port has 2 main registers:

- Data Register (DR)
- Data Direction Register (DDR)

and one optional register:

- Option Register (OR)

Each I/O pin may be programmed using the corresponding register bits in the DDR and OR registers: bit X corresponding to pin X of the port. The same correspondence is used for the DR register.

The following description takes into account the OR register, (for specific ports which do not provide this register refer to the I/O Port Implementation section). The generic I/O block diagram is shown in [Figure 32](#)

10.2.1 Input Modes

The input configuration is selected by clearing the corresponding DDR register bit.

In this case, reading the DR register returns the digital value applied to the external I/O pin.

Different input modes can be selected by software through the OR register.

Notes:

1. Writing the DR register modifies the latch value but does not affect the pin status.
2. PA3 cannot be configured as input.

10.2.1.1 External interrupt function

When an I/O is configured as Input with Interrupt, an event on this I/O can generate an external interrupt request to the CPU.

Each pin can independently generate an interrupt request. The interrupt sensitivity is independently programmable using the sensitivity bits in the EICR register.

Each external interrupt vector is linked to a dedicated group of I/O port pins (see pinout description and interrupt section). If several I/O interrupt pins on the same interrupt vector are selected simultaneously, they are logically combined. For this reason if one of the interrupt pins is tied low, it may mask the others.

External interrupts are hardware interrupts. Fetching the corresponding interrupt vector automatically clears the request latch. Changing the sensitivity of a particular external interrupt clears this pending interrupt. This can be used to clear unwanted pending interrupts.

Spurious interrupts

When enabling/disabling an external interrupt by setting/resetting the related OR register bit, a spurious interrupt is generated if the pin level is low and its edge sensitivity includes falling/rising edge. This is due to the edge detector input which is switched to '1' when the external interrupt is disabled by the OR register.

To avoid this unwanted interrupt, a "safe" edge sensitivity (rising edge for enabling and falling edge for disabling) has to be selected before changing the OR register bit and configuring the appropriate sensitivity again.

Caution: In case a pin level change occurs during these operations (asynchronous signal input), as interrupts are generated according to the current sensitivity, it is advised to disable all interrupts before and to reenble them after the complete previous sequence in order to avoid an external interrupt occurring on the unwanted edge.

This corresponds to the following steps:

1. To enable an external interrupt:
 - set the interrupt mask with the SIM instruction (in cases where a pin level change could occur)
 - select rising edge
 - enable the external interrupt through the OR register
 - select the desired sensitivity if different from rising edge
 - reset the interrupt mask with the RIM instruction (in cases where a pin level change could occur)
2. To disable an external interrupt:
 - set the interrupt mask with the SIM instruction SIM (in cases where a pin level change could occur)

- occur)
- select falling edge
 - disable the external interrupt through the OR register
 - select rising edge

10.2.2 Output Modes

The output configuration is selected by setting the corresponding DDR register bit. In this case, writing the DR register applies this digital value to the I/O pin through the latch. Then reading the DR register returns the previously stored value.

Two different output modes can be selected by software through the OR register: Output push-pull and open-drain.

DR register value and output pin status:

| DR | Push-pull | Open-drain |
|----|-----------|------------|
| 0 | V_{SS} | V_{SS} |
| 1 | V_{DD} | Floating |

Note: When switching from input to output mode, the DR register has to be written first to drive the

correct level on the pin as soon as the port is configured as an output.

10.2.3 Alternate Functions

When an on-chip peripheral is configured to use a pin, the alternate function is automatically selected. This alternate function takes priority over the standard I/O programming under the following conditions:

- When the signal is coming from an on-chip peripheral, the I/O pin is automatically configured in output mode (push-pull or open drain according to the peripheral).
- When the signal is going to an on-chip peripheral, the I/O pin must be configured in floating input mode. In this case, the pin state is also digitally readable by addressing the DR register.

Notes:

- Input pull-up configuration can cause unexpected value at the input of the alternate peripheral input.
- When an on-chip peripheral use a pin as input and output, this pin has to be configured in input floating mode.

Figure 32. I/O Port General Block Diagram

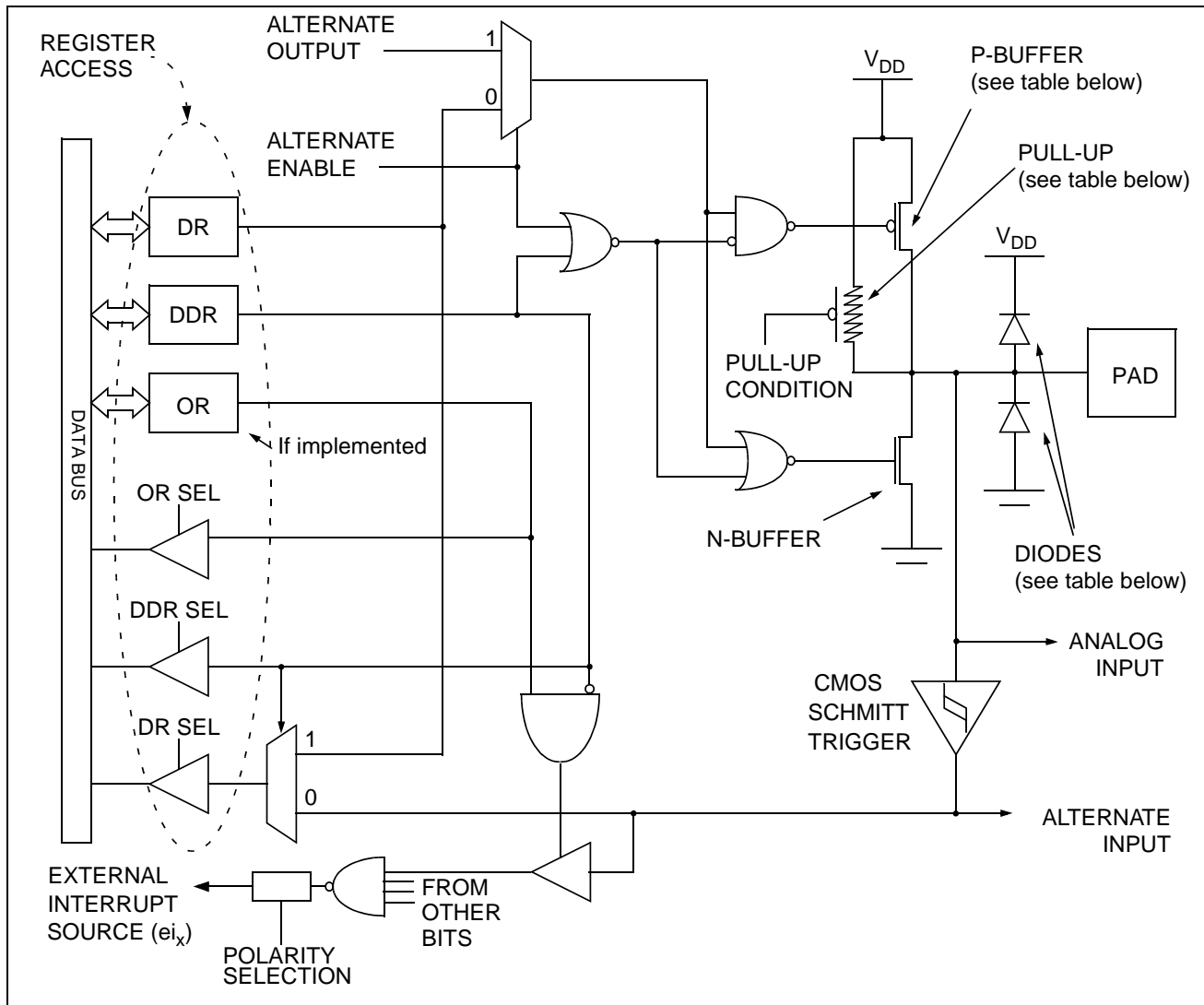

Table 15. I/O Port Mode Options

| Configuration Mode | | Pull-Up | P-Buffer | Diodes | |
|--------------------|---------------------------------|---------|----------|--------------------|--------------------|
| | | | | to V _{DD} | to V _{SS} |
| Input | Floating with/without Interrupt | Off | Off | On | On |
| | Pull-up with/without Interrupt | On | Off | | |
| Output | Push-pull | Off | On | On | On |
| | Open Drain (logic level) | | Off | | |

Legend: NI - not implemented
 Off - implemented not activated
 On - implemented and activated

I/O PORTS (Cont'd)

Table 16. I/O Port Configurations

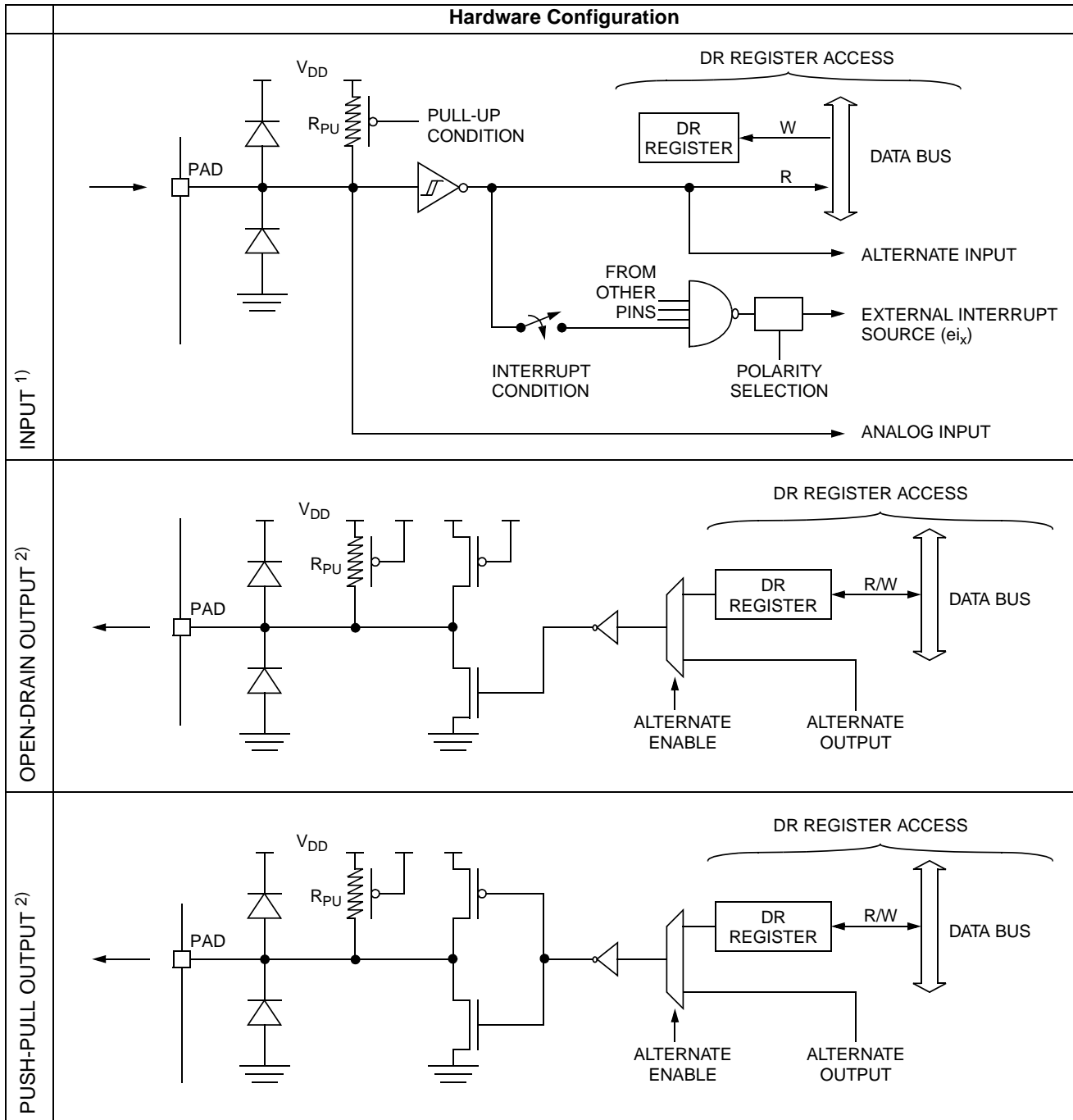

Notes:

1. When the I/O port is in input configuration and the associated alternate function is enabled as an output, reading the DR register will read the alternate function output status.
2. When the I/O port is in output configuration and the associated alternate function is enabled as an input, the alternate function reads the pin status given by the DR register content.

I/O PORTS (Cont'd)

CAUTION: The alternate function must not be activated as long as the pin is configured as input with interrupt, in order to avoid generating spurious interrupts.

Analog alternate function

When the pin is used as an ADC input, the I/O must be configured as floating input. The analog multiplexer (controlled by the ADC registers) switches the analog voltage present on the selected pin to the common analog rail which is connected to the ADC input.

It is recommended not to change the voltage level or loading on any port pin while conversion is in progress. Furthermore it is recommended not to have clocking pins located close to a selected analog pin.

WARNING: The analog input voltage level must be within the limits stated in the absolute maximum ratings.

10.3 UNUSED I/O PINS

Unused I/O pins must be connected to fixed voltage levels. Refer to [Section 13.8](#).

10.4 LOW POWER MODES

| Mode | Description |
|------|--|
| WAIT | No effect on I/O ports. External interrupts cause the device to exit from WAIT mode. |
| HALT | No effect on I/O ports. External interrupts cause the device to exit from HALT mode. |

10.5 INTERRUPTS

The external interrupt event generates an interrupt if the corresponding configuration is selected with DDR and OR registers and the interrupt mask in the CC register is not active (RIM instruction).

| Interrupt Event | Event Flag | Enable Control Bit | Exit from Wait | Exit from Halt |
|---|------------|--------------------|----------------|----------------|
| External interrupt on selected external event | - | DDRx ORx | Yes | Yes |

10.6 I/O PORT IMPLEMENTATION

The hardware implementation on each I/O port depends on the settings in the DDR and OR registers and specific feature of the I/O port such as ADC Input or true open drain.

Switching these I/O ports from one state to another should be done in a sequence that prevents unwanted side effects. Recommended safe transitions are illustrated in [Figure 33](#). Other transitions are potentially risky and should be avoided, since they are likely to present unwanted side-effects such as spurious interrupt generation.

Figure 33. Interrupt I/O Port State Transitions

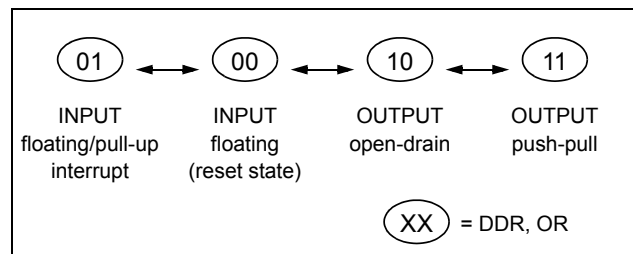

The I/O port register configurations are summarised in the following table:

Table 17. Port Configuration

| Port | Pin name | Input (DDR=0) | | Output (DDR=1) | |
|--------|----------------------------|---------------|---------------------------------|----------------|-----------|
| | | OR = 0 | OR = 1 | OR = 0 | OR = 1 |
| Port A | PA0:2, PA4:5 ¹⁾ | floating | pull-up interrupt ¹⁾ | open drain | push-pull |
| | PA3 ²⁾ | - | - | open drain | push-pull |

Notes:

- IS4[1:0] = 01 is the only safe configuration to avoid spurious interrupt in HALT and AWUFH modes. Refer to EICR2 description on [page 33](#).
- After reset, to configure PA3 as a general purpose output, the application has to program the MUXCR0 and MUXCR1 registers. See [section 7.4 on page 30](#)

I/O PORTS (Cont'd)

Table 18. I/O Port Register Map and Reset Values

| Address (Hex.) | Register Label | 7 | 6 | 5 | 4 | 3 | 2 | 1 | 0 |
|-------------------|----------------------|----------|---|---|---|---|---|---|----------|
| 0000h | PADR Reset Value | MSB 0 | 0 | 0 | 0 | 0 | 0 | 0 | LSB 0 |
| 0001h | PADDR Reset Value | MSB 0 | 0 | 0 | 0 | 1 | 0 | 0 | LSB 0 |
| 0002h | PAOR Reset Value | MSB 0 | 0 | 0 | 0 | 0 | 0 | 1 | LSB 0 |

11 ON-CHIP PERIPHERALS

11.1 LITE TIMER (LT)

11.1.1 Introduction

The Lite Timer can be used for general-purpose timing functions. It is based on a free-running 13-bit upcounter with two software-selectable timebase periods, an 8-bit input capture register and watchdog function.

11.1.2 Main Features

- Realtime Clock
 - 13-bit upcounter
 - 1 ms or 2 ms timebase period (@ 8 MHz f_{OSC})
 - Maskable timebase interrupt
- Input Capture
 - 8-bit input capture register (LTICR)
 - Maskable interrupt with wakeup from Halt Mode capability
- Watchdog
 - Enabled by hardware or software (configurable by option byte)
 - Optional reset on HALT instruction (configurable by option byte)
 - Automatically resets the device unless disable bit is refreshed
 - Software reset (Forced Watchdog reset)
 - Watchdog reset status flag

Figure 34. Lite Timer Block Diagram

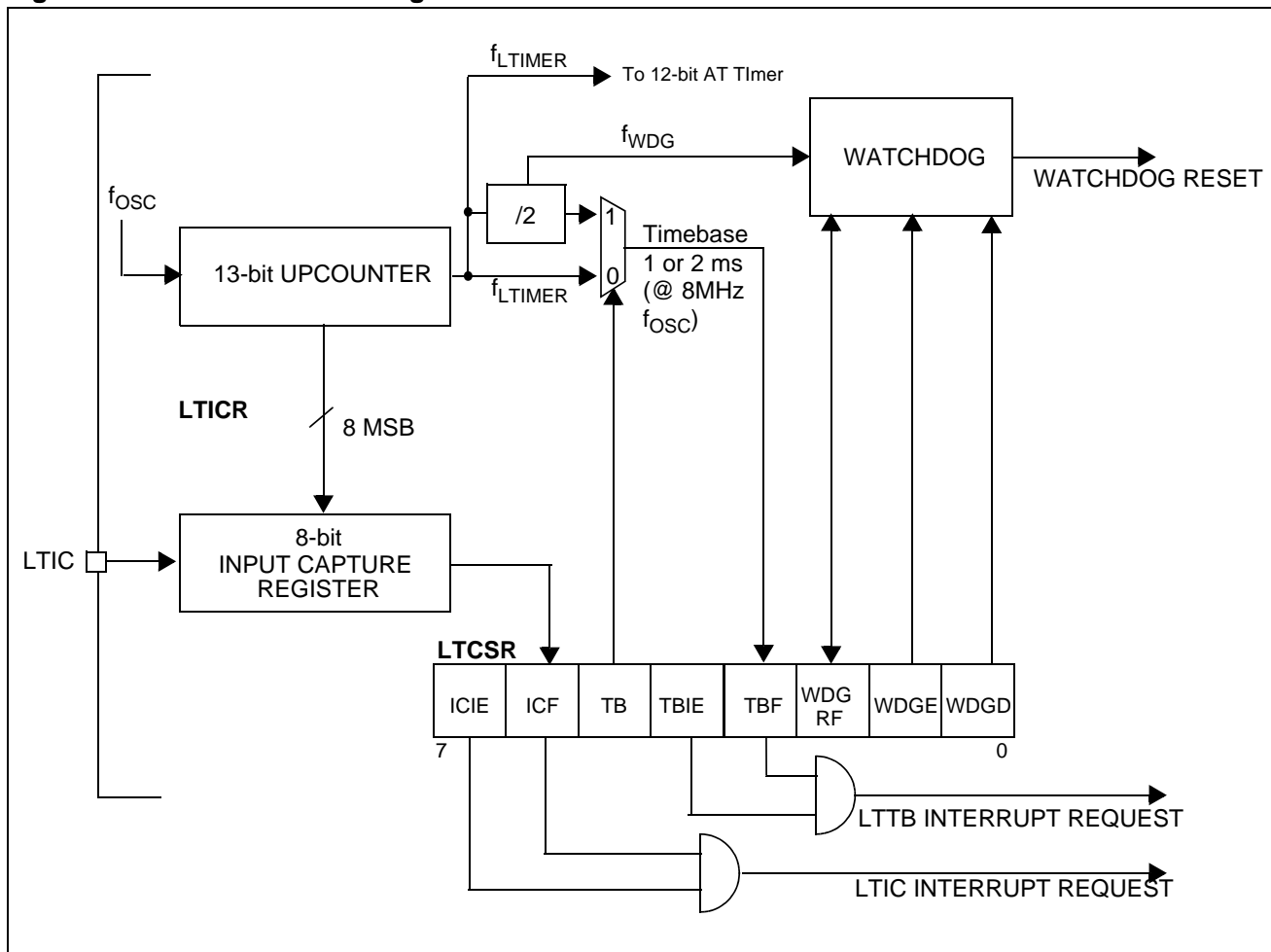

LITE TIMER (Cont'd)

11.1.3 Functional Description

The value of the 13-bit counter cannot be read or written by software. After an MCU reset, it starts incrementing from 0 at a frequency of f_{OSC} . A counter overflow event occurs when the counter rolls over from 1F39h to 00h. If $f_{OSC} = 8$ MHz, then the time period between two counter overflow events is 1 ms. This period can be doubled by setting the TB bit in the LTCSR register.

When the timer overflows, the TBF bit is set by hardware and an interrupt request is generated if the TBIE is set. The TBF bit is cleared by software reading the LTCSR register.

11.1.3.1 Watchdog

The watchdog is enabled using the WDGE bit. The normal Watchdog timeout is 2ms (@ $f_{osc} = 8$ MHz), after which it then generates a reset.

To prevent this watchdog reset occurring, software must set the WDGD bit. The WDGD bit is cleared by hardware after t_{WDG} . This means that software must write to the WDGD bit at regular intervals to prevent a watchdog reset occurring. Refer to [Figure 35](#).

If the watchdog is not enabled immediately after reset, the first watchdog timeout will be shorter than 2ms, because this period is counted starting from reset. Moreover, if a 2ms period has already elapsed after the last MCU reset, the watchdog reset will take place as soon as the WDGE bit is set. For these reasons, it is recommended to enable the Watchdog immediately after reset or else to set the WDGD bit before the WGDE bit so a watchdog reset will not occur for at least 2ms.

Note: Software can use the timebase feature to set the WDGD bit at 1 or 2 ms intervals.

A Watchdog reset can be forced at any time by setting the WDGRF bit. To generate a forced watchdog reset, first watchdog has to be activated by setting the WDGE bit and then the WDGRF bit has to be set.

The WDGRF bit also acts as a flag, indicating that the Watchdog was the source of the reset. It is automatically cleared after it has been read.

Caution: When the WDGRF bit is set, software must clear it, otherwise the next time the watchdog is enabled (by hardware or software), the microcontroller will be immediately reset.

Hardware Watchdog Option

If Hardware Watchdog is selected by option byte, the watchdog is always active and the WDGE bit in the LTCSR is not used.

Refer to the Option Byte description in the "device configuration and ordering information" section.

Using Halt Mode with the Watchdog (option)

If the Watchdog reset on HALT option is not selected by option byte, the Halt mode can be used when the watchdog is enabled.

In this case, the HALT instruction stops the oscillator. When the oscillator is stopped, the Lite Timer stops counting and is no longer able to generate a Watchdog reset until the microcontroller receives an external interrupt or a reset.

If an external interrupt is received, the WDG restarts counting after 256 or 512 CPU clocks. If a reset is generated, the Watchdog is disabled (reset state).

If Halt mode with Watchdog is enabled by option byte (No watchdog reset on HALT instruction), it is recommended before executing the HALT instruction to refresh the WDG counter, to avoid an unexpected WDG reset immediately after waking up the microcontroller.

Figure 35. Watchdog Timing Diagram

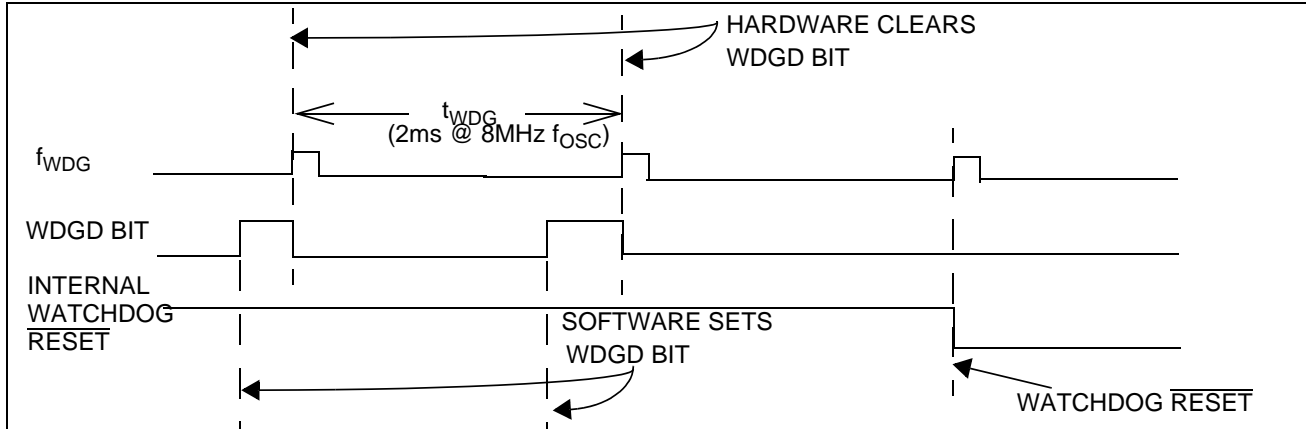

LITE TIMER (Cont'd)

Input Capture

The 8-bit input capture register is used to latch the free-running upcounter after a rising or falling edge is detected on the LTIC pin. When an input capture occurs, the ICF bit is set and the LTICR register contains the MSB of the free-running upcounter. An interrupt is generated if the ICIE bit is set. The ICF bit is cleared by reading the LTICR register.

The LTICR is a read only register and always contains the data from the last input capture. Input capture is inhibited if the ICF bit is set.

11.1.4 Low Power Modes

| Mode | Description |
|-------------|---------------------------|
| WAIT | No effect on Lite timer |
| ACTIVE-HALT | No effect on Lite timer |
| HALT | Lite timer stops counting |

11.1.5 Interrupts

| Interrupt Event | Event Flag | Enable Control Bit | Exit from Wait | Exit from Halt | Exit from Active-Halt |
|-----------------|------------|--------------------|----------------|----------------|-----------------------|
| Timebase Event | TBF | TBIE | Yes | No | Yes |
| IC Event | ICF | ICIE | Yes | No | No |

Note: The TBF and ICF interrupt events are connected to separate interrupt vectors (see Interrupts chapter).

They generate an interrupt if the enable bit is set in the LTCSR register and the interrupt mask in the CC register is reset (RIM instruction).

Figure 36. Input Capture Timing Diagram

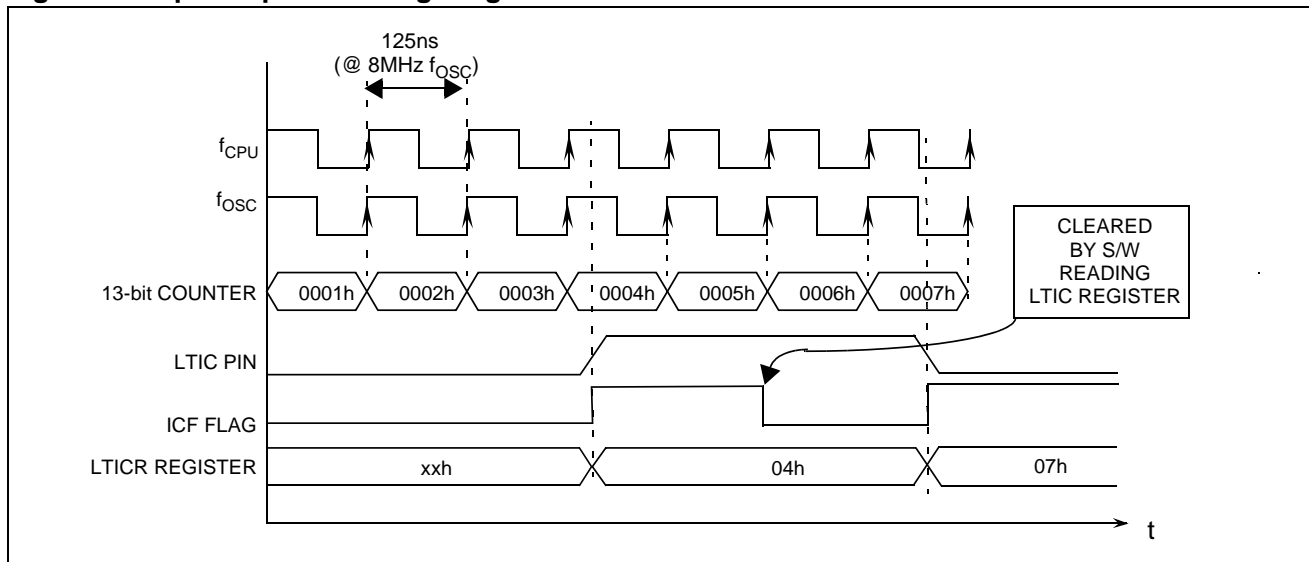

LITE TIMER (Cont'd)

11.1.6 Register Description

LITE TIMER CONTROL/STATUS REGISTER (LTCSR)

Read / Write

Reset Value: 0000 0x00 (0xh)

| | | | | | | | |
|------|-----|----|------|-----|----------|------|----------|
| 7 | | | | | | | 0 |
| ICIE | ICF | TB | TBIE | TBF | WDG R | WDGE | WDG D |

Bit 7 = **ICIE** *Interrupt Enable*.

This bit is set and cleared by software.

0: Input Capture (IC) interrupt disabled

1: Input Capture (IC) interrupt enabled

Bit 6 = **ICF** *Input Capture Flag*.

This bit is set by hardware and cleared by software by reading the LTICR register. Writing to this bit does not change the bit value.

0: No input capture

1: An input capture has occurred

Note: After an MCU reset, software must initialise the ICF bit by reading the LTICR registerBit 5 = **TB** *Timebase period selection*.

This bit is set and cleared by software.

0: Timebase period = $t_{OSC} * 8000$ (1ms @ 8 MHz)1: Timebase period = $t_{OSC} * 16000$ (2ms @ 8 MHz)Bit 4 = **TBIE** *Timebase Interrupt enable*.

This bit is set and cleared by software.

0: Timebase (TB) interrupt disabled

1: Timebase (TB) interrupt enabled

Bit 3 = **TBF** *Timebase Interrupt Flag*.

This bit is set by hardware and cleared by software reading the LTCSR register. Writing to this bit has no effect.

0: No counter overflow

1: A counter overflow has occurred

Bit 2 = **WDGRF** *Force Reset/ Reset Status Flag*

This bit is used in two ways: it is set by software to force a watchdog reset. It is set by hardware when a watchdog reset occurs and cleared by hardware or by software. It is cleared by hardware only when an LVD reset occurs. It can be cleared by software after a read access to the LTCSR register.

0: No watchdog reset occurred.

1: Force a watchdog reset (write), or, a watchdog reset occurred (read).

Bit 1 = **WDGE** *Watchdog Enable*

This bit is set and cleared by software.

0: Watchdog disabled

1: Watchdog enabled

Bit 0 = **WDGD** *Watchdog Reset Delay*This bit is set by software. It is cleared by hardware at the end of each t_{WDG} period.

0: Watchdog reset not delayed

1: Watchdog reset delayed

LITE TIMER INPUT CAPTURE REGISTER (LTICR)

Read only

Reset Value: 0000 0000 (00h)

| | | | | | | | |
|------|------|------|------|------|------|------|------|
| 7 | | | | | | | 0 |
| ICR7 | ICR6 | ICR5 | ICR4 | ICR3 | ICR2 | ICR1 | ICR0 |

Bits 7:0 = **ICR[7:0]** *Input Capture Value*

These bits are read by software and cleared by hardware after a reset. If the ICF bit in the LTCSR is cleared, the value of the 8-bit up-counter will be captured when a rising or falling edge occurs on the LTIC pin.

Table 19. Lite Timer Register Map and Reset Values

| Address (Hex.) | Register Label | 7 | 6 | 5 | 4 | 3 | 2 | 1 | 0 |
|----------------|-----------------------------|-----------|-----------|-----------|-----------|-----------|------------|-----------|-----------|
| 0B | LTCSR Reset Value | ICIE 0 | ICF 0 | TB 0 | TBIE 0 | TBF 0 | WDGRF x | WDGE 0 | WDGD 0 |
| 0C | LTICR Reset Value | ICR7 0 | ICR6 0 | ICR5 0 | ICR4 0 | ICR3 0 | ICR2 0 | ICR1 0 | ICR0 0 |

11.2 12-BIT AUTORELOAD TIMER (AT)

11.2.1 Introduction

The 12-bit Autoreload Timer can be used for general-purpose timing functions. It is based on a free-running 12-bit upcounter with a PWM output channel.

11.2.2 Main Features

- 12-bit upcounter with 12-bit autoreload register (ATR)
- Maskable overflow interrupt

- PWM signal generator
- Frequency range 2KHz-4MHz (@ 8 MHz f_{CPU})
 - Programmable duty-cycle
 - Polarity control
 - Maskable Compare interrupt
- Output Compare Function

Figure 37. Block Diagram

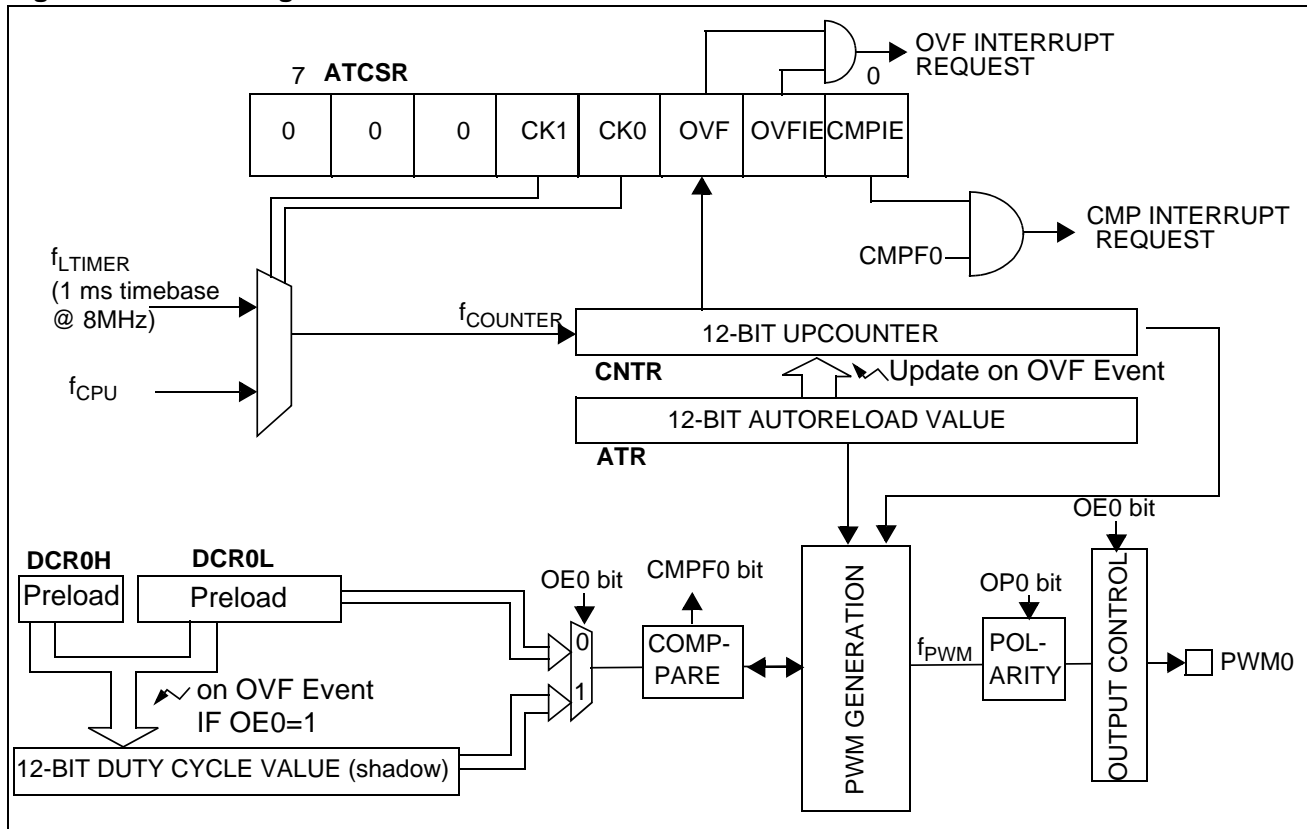

12-BIT AUTORELOAD TIMER (Cont'd)

11.2.3 Functional Description

PWM Mode

This mode allows a Pulse Width Modulated signals to be generated on the PWM0 output pin with minimum core processing overhead. The PWM0 output signal can be enabled or disabled using the OE0 bit in the PWMCR register. When this bit is set the PWM I/O pin is configured as output push-pull alternate function.

Note: CMPF0 is available in PWM mode (see PWM0CSR description on [page 62](#)).

PWM Frequency and Duty Cycle

The PWM signal frequency (f_{PWM}) is controlled by the counter period and the ATR register value.

$$f_{PWM} = f_{COUNTER} / (4096 - ATR)$$

Following the above formula, if f_{CPU} is 8 MHz, the maximum value of f_{PWM} is 4 Mhz (ATR register value = 4094), and the minimum value is 2 kHz (ATR register value = 0).

Note: The maximum value of ATR is 4094 because it must be lower than the DCR value which must be 4095 in this case.

At reset, the counter starts counting from 0.

Software must write the duty cycle value in the DCR0H and DCR0L preload registers. The DCR0H register must be written first. See caution below.

When a upcounter overflow occurs (OVF event), the ATR value is loaded in the upcounter, the preloaded Duty cycle value is transferred to the Duty Cycle register and the PWM0 signal is set to a high level. When the upcounter matches the DCRx value the PWM0 signals is set to a low level. To obtain a signal on the PWM0 pin, the contents of the DCR0 register must be greater than the contents of the ATR register.

The polarity bit can be used to invert the output signal.

The maximum available resolution for the PWM0 duty cycle is:

$$\text{Resolution} = 1 / (4096 - ATR)$$

Note: To get the maximum resolution (1/4096), the ATR register must be 0. With this maximum resolution and assuming that $DCR=ATR$, a 0% or 100% duty cycle can be obtained by changing the polarity .

Caution: As soon as the DCR0H is written, the compare function is disabled and will start only when the DCR0L value is written. If the DCR0H write occurs just before the compare event, the signal on the PWM output may not be set to a low level. In this case, the DCRx register should be updated just after an OVF event. If the DCR and ATR values are close, then the DCRx register should be updated just before an OVF event, in order not to miss a compare event and to have the right signal applied on the PWM output.

Figure 38. PWM Function

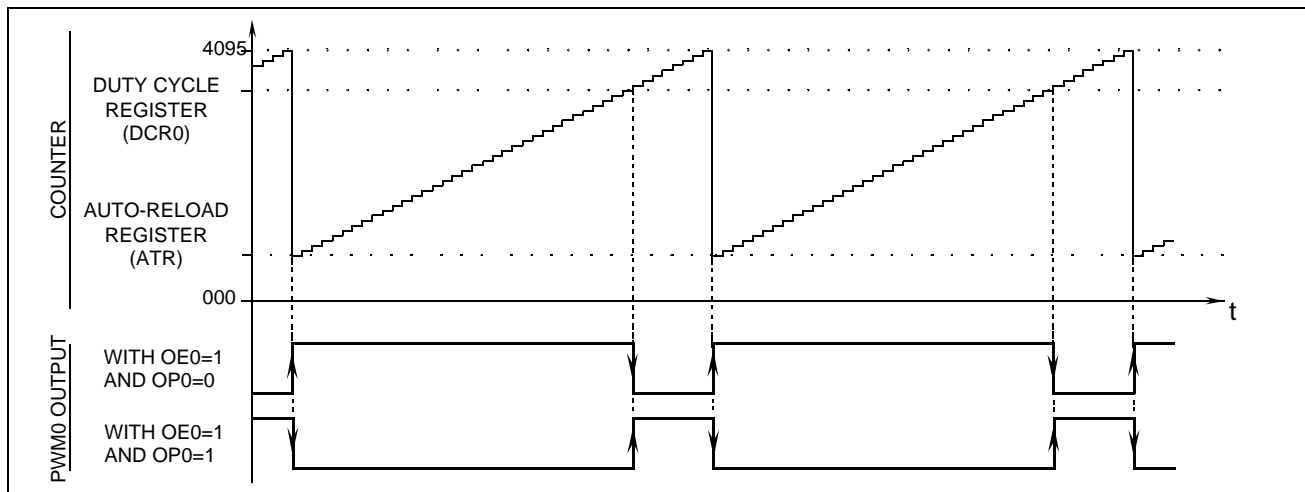

12-BIT AUTORELOAD TIMER (Cont'd)

Figure 39. PWM Signal Example

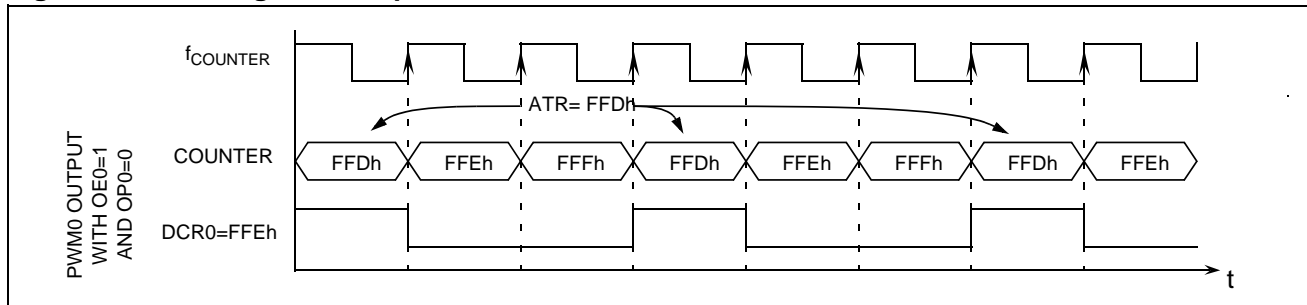

Output Compare Mode

To use this function, the OE bit must be 0, otherwise the compare is done with the shadow register instead of the DCRx register. Software must then write a 12-bit value in the DCR0H and DCR0L registers. This value will be loaded immediately (without waiting for an OVF event).

The DCR0H must be written first, the output compare function starts only when the DCR0L value is written.

When the 12-bit upcounter (CNTR) reaches the value stored in the DCR0H and DCR0L registers, the CMPF0 bit in the PWM0CSR register is set and an interrupt request is generated if the CMPIE bit is set.

Note: The output compare function is only available for DCRx values other than 0 (reset value).

Caution: At each OVF event, the DCRx value is written in a shadow register, even if the DCR0L value has not yet been written (in this case, the shadow register will contain the new DCR0H value and the old DCR0L value), then:

- If OE=1 (PWM mode): the compare is done between the timer counter and the shadow register (and not DCRx)
- if OE=0 (OCMP mode): the compare is done between the timer counter and DCRx. There is no PWM signal.

The compare between DCRx or the shadow register and the timer counter is locked until DCR0L is written.

11.2.4 Low Power Modes

| Mode | Description |
|-------------|--|
| SLOW | The input frequency is divided by 32 |
| WAIT | No effect on AT timer |
| ACTIVE-HALT | AT timer halted except if CK0=1, CK1=0 and OVFIE=1 |
| HALT | AT timer halted |

11.2.5 Interrupts

| Interrupt Event ¹⁾ | Event Flag | Enable Control Bit | Exit from Wait | Exit from Halt | Exit from Active-Halt |
|-------------------------------|------------|--------------------|----------------|----------------|-----------------------|
| Overflow Event | OVF | OVFIE | Yes | No | Yes ²⁾ |
| CMP Event | CMPFx | CMPIE | Yes | No | No |

Note 1: The interrupt events are connected to separate interrupt vectors (see Interrupts chapter). They generate an interrupt if the enable bit is set in the ATCSR register and the interrupt mask in the CC register is reset (RIM instruction).

Note 2: only if CK0=1 and CK1=0

12-BIT AUTORELOAD TIMER (Cont'd)**11.2.6 Register Description****TIMER CONTROL STATUS REGISTER (ATCSR)**

Read / Write

Reset Value: 0000 0000 (00h)

| | | | | | | | |
|---|---|---|-----|-----|-----|-------|-------|
| 7 | | | | | | | 0 |
| 0 | 0 | 0 | CK1 | CK0 | OVF | OVFIE | CMPIE |

Bits 7:5 = Reserved, must be kept cleared.

Bits 4:3 = **CK[1:0]** Counter Clock Selection.

These bits are set and cleared by software and cleared by hardware after a reset. They select the clock frequency of the counter.

| Counter Clock Selection | CK1 | CK0 |
|--|-----|-----|
| OFF | 0 | 0 |
| f_{TIMER} (1 ms timebase @ 8 MHz) | 0 | 1 |
| f_{CPU} | 1 | 0 |
| Reserved | 1 | 1 |

Bit 2 = **OVF** Overflow Flag.

This bit is set by hardware and cleared by software by reading the ATCSR register. It indicates the transition of the counter from FFFh to ATR value.

0: No counter overflow occurred

1: Counter overflow occurred

Caution:When set, the OVF bit stays high for 1 f_{COUNTER} cycle (up to 1ms depending on the clock selection) after it has been cleared by software.Bit 1 = **OVFIE** Overflow Interrupt Enable.

This bit is read/write by software and cleared by hardware after a reset.

0: OVF interrupt disabled

1: OVF interrupt enabled

Bit 0 = **CMPIE** Compare Interrupt Enable.

This bit is read/write by software and clear by hardware after a reset. It allows to mask the interrupt generation when CMPF bit is set.

0: CMPF interrupt disabled

1: CMPF interrupt enabled

COUNTER REGISTER HIGH (CNTRH)

Read only

Reset Value: 0000 0000 (00h)

| | | | | | | | |
|----|---|---|---|------|------|-----|-----|
| 15 | | | | | | | 8 |
| 0 | 0 | 0 | 0 | CN11 | CN10 | CN9 | CN8 |

COUNTER REGISTER LOW (CNTRL)

Read only

Reset Value: 0000 0000 (00h)

| | | | | | | | |
|-----|-----|-----|-----|-----|-----|-----|-----|
| 7 | | | | | | | 0 |
| CN7 | CN6 | CN5 | CN4 | CN3 | CN2 | CN1 | CN0 |

Bits 15:12 = Reserved, must be kept cleared.

Bits 11:0 = **CNTR[11:0]** Counter Value.This 12-bit register is read by software and cleared by hardware after a reset. The counter is incremented continuously as soon as a counter clock is selected. To obtain the 12-bit value, software should read the counter value in two consecutive read operations. As there is no latch, it is recommended to read LSB first. In this case, CNTRH can be incremented between the two read operations and to have an accurate result when $f_{\text{timer}}=f_{\text{CPU}}$, special care must be taken when CNTRL values close to FFh are read.

When a counter overflow occurs, the counter restarts from the value specified in the ATR register.

12-BIT AUTORELOAD TIMER (Cont'd)

AUTO RELOAD REGISTER (ATRH)

Read / Write
Reset Value: 0000 0000 (00h)

| | | | | | | | |
|----|---|---|---|-------|-------|------|------|
| 15 | | | | | 8 | | |
| 0 | 0 | 0 | 0 | ATR11 | ATR10 | ATR9 | ATR8 |

AUTO RELOAD REGISTER (ATRL)

Read / Write
Reset Value: 0000 0000 (00h)

| | | | | | | | | |
|------|------|------|------|------|------|------|------|---|
| 7 | | | | | | | | 0 |
| ATR7 | ATR6 | ATR5 | ATR4 | ATR3 | ATR2 | ATR1 | ATRO | |

Bits 15:12 = Reserved, must be kept cleared.

Bits 11:0 = **ATR[11:0]** *Autoreload Register*.
This is a 12-bit register which is written by software. The ATR register value is automatically loaded into the upcounter when an overflow occurs. The register value is used to set the PWM frequency.

PWM0 DUTY CYCLE REGISTER HIGH (DCR0H)

Read / Write
Reset Value: 0000 0000 (00h)

| | | | | | | | |
|----|---|---|---|-------|-------|------|------|
| 15 | | | | | 8 | | |
| 0 | 0 | 0 | 0 | DCR11 | DCR10 | DCR9 | DCR8 |

PWM0 DUTY CYCLE REGISTER LOW (DCR0L)

Read / Write
Reset Value: 0000 0000 (00h)

| | | | | | | | |
|------|------|------|------|------|------|------|------|
| 7 | | | | | | | 0 |
| DCR7 | DCR6 | DCR5 | DCR4 | DCR3 | DCR2 | DCR1 | DCR0 |

Bits 15:12 = Reserved, must be kept cleared.

Bits 11:0 = **DCR[11:0]** *PWMx Duty Cycle Value*
This 12-bit value is written by software. The high register must be written first.

In PWM mode (OE0=1 in the PWMCR register) the DCR[11:0] bits define the duty cycle of the PWM0 output signal (see [Figure 38](#)). In Output Compare mode, (OE0=0 in the PWMCR register) they define the value to be compared with the 12-bit upcounter value.

PWM0 CONTROL/STATUS REGISTER (PWM0CSR)

Read / Write
Reset Value: 0000 0000 (00h)

| | | | | | | | |
|---|---|---|---|---|---|-----|-------|
| 7 | | | | | | | 0 |
| 0 | 0 | 0 | 0 | 0 | 0 | OP0 | CMPF0 |

Bit 7:2= Reserved, must be kept cleared.

Bit 1 = **OP0** *PWM0 Output Polarity*.
This bit is read/write by software and cleared by hardware after a reset. This bit selects the polarity of the PWM0 signal.
0: The PWM0 signal is not inverted.
1: The PWM0 signal is inverted.

Bit 0 = **CMPF0** *PWM0 Compare Flag*.
This bit is set by hardware and cleared by software by reading the PWM0CSR register. It indicates that the upcounter value matches the DCR0 register value.
0: Upcounter value does not match DCR value.
1: Upcounter value matches DCR value.

12-BIT AUTORELOAD TIMER (Cont'd)**PWM OUTPUT CONTROL REGISTER (PWMCR)**

Read/Write

Reset Value: 0000 0000 (00h)

| | | | | | | | |
|---|---|---|---|---|---|---|-----|
| 7 | | | | | | | 0 |
| 0 | 0 | 0 | 0 | 0 | 0 | 0 | OE0 |

Bits 7:1 = Reserved, must be kept cleared.

Bit 0 = **OE0** PWM0 Output enable.

This bit is set and cleared by software.

0: PWM0 output Alternate Function disabled (I/O pin free for general purpose I/O)

1: PWM0 output enabled

Table 20. Register Map and Reset Values

| Address (Hex.) | Register Label | 7 | 6 | 5 | 4 | 3 | 2 | 1 | 0 |
|----------------|-------------------------------|-----------|-----------|-----------|-----------|------------|------------|------------|------------|
| 0D | ATCSR Reset Value | 0 | 0 | 0 | CK1 0 | CK0 0 | OVF 0 | OVFIE 0 | CMPIE 0 |
| 0E | CNTRH Reset Value | 0 | 0 | 0 | 0 | CN11 0 | CN10 0 | CN9 0 | CN8 0 |
| 0F | CNTRL Reset Value | CN7 0 | CN6 0 | CN5 0 | CN4 0 | CN3 0 | CN2 0 | CN1 0 | CN0 0 |
| 10 | ATRH Reset Value | 0 | 0 | 0 | 0 | ATR11 0 | ATR10 0 | ATR9 0 | ATR8 0 |
| 11 | ATRL Reset Value | ATR7 0 | ATR6 0 | ATR5 0 | ATR4 0 | ATR3 0 | ATR2 0 | ATR1 0 | ATR0 0 |
| 12 | PWMCR Reset Value | 0 | 0 | 0 | 0 | 0 | 0 | 0 | OE0 0 |
| 13 | PWM0CSR Reset Value | 0 | 0 | 0 | 0 | 0 | 0 | OP 0 | CMPF0 0 |
| 17 | DCR0H Reset Value | 0 | 0 | 0 | 0 | DCR11 0 | DCR10 0 | DCR9 0 | DCR8 0 |
| 18 | DCR0L Reset Value | DCR7 0 | DCR6 0 | DCR5 0 | DCR4 0 | DCR3 0 | DCR2 0 | DCR1 0 | DCR0 0 |

11.3 10-BIT A/D CONVERTER (ADC)

11.3.1 Introduction

The on-chip Analog to Digital Converter (ADC) peripheral is a 10-bit, successive approximation converter with internal sample and hold circuitry. This peripheral has up to 5 multiplexed analog input channels (refer to device pin out description) that allow the peripheral to convert the analog voltage levels from up to 5 different sources.

The result of the conversion is stored in a 10-bit Data Register. The A/D converter is controlled through a Control/Status Register.

11.3.2 Main Features

- 10-bit conversion
- Up to 5 channels with multiplexed input

- Linear successive approximation
- Data register (DR) which contains the results
- Conversion complete status flag
- On/off bit (to reduce consumption)

The block diagram is shown in [Figure 40](#).

11.3.3 Functional Description

11.3.3.1 Analog Power Supply

V_{DD} and V_{SS} are the high and low level reference voltage pins.

Conversion accuracy may therefore be impacted by voltage drops and noise in the event of heavily loaded or badly decoupled power supply lines.

Figure 40. ADC Block Diagram

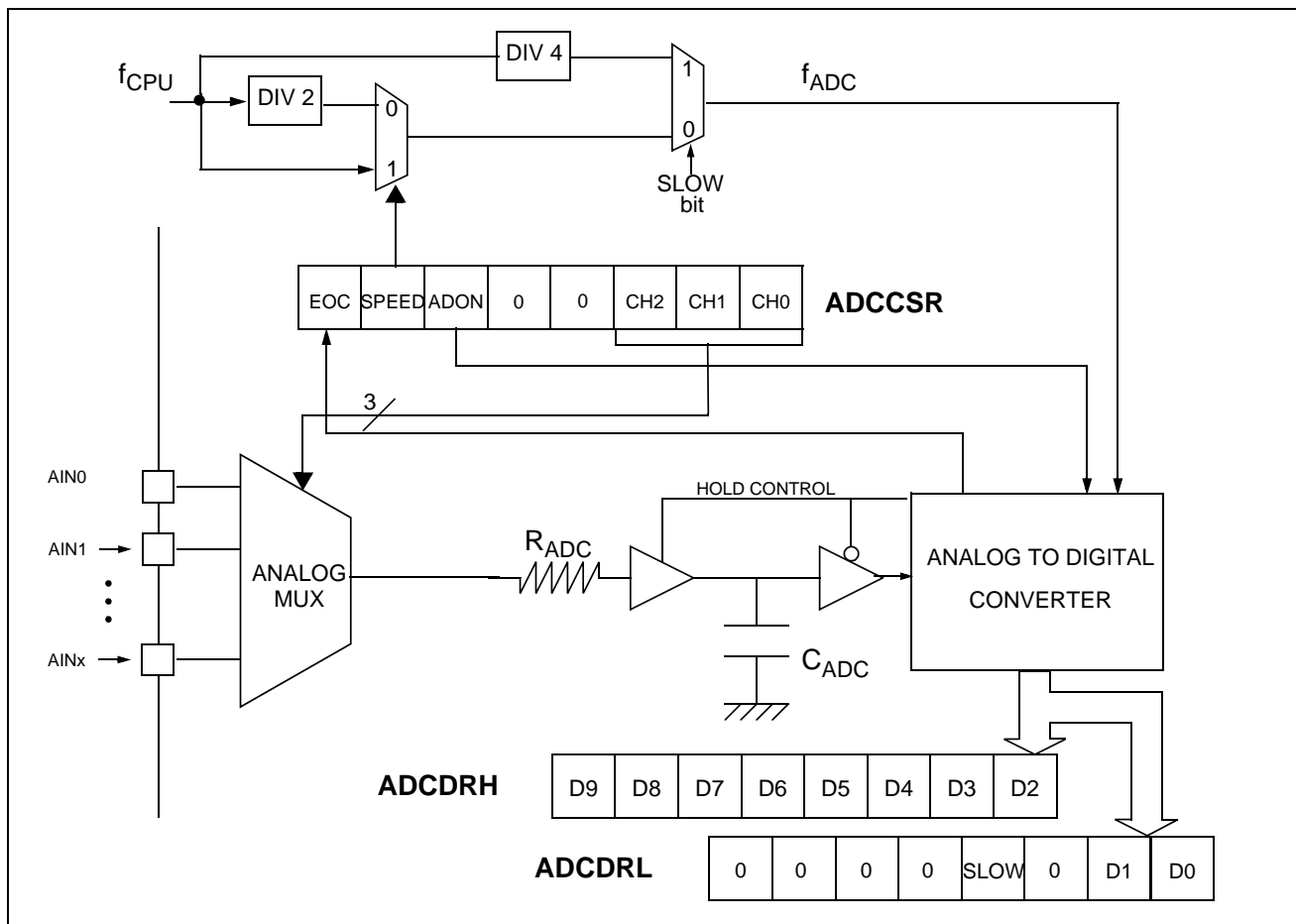

10-BIT A/D CONVERTER (ADC) (Cont'd)

11.3.3.2 Digital A/D Conversion Result

The conversion is monotonic, meaning that the result never decreases if the analog input does not and never increases if the analog input does not.

If the input voltage (V_{AIN}) is greater than V_{DD} (high-level voltage reference) then the conversion result is FFh in the ADCDRH register and 03h in the ADCDRL register (without overflow indication).

If the input voltage (V_{AIN}) is lower than V_{SS} (low-level voltage reference) then the conversion result in the ADCDRH and ADCDRL registers is 00 00h.

The A/D converter is linear and the digital result of the conversion is stored in the ADCDRH and ADCDRL registers. The accuracy of the conversion is described in the Electrical Characteristics Section.

R_{AIN} is the maximum recommended impedance for an analog input signal. If the impedance is too high, this will result in a loss of accuracy due to leakage and sampling not being completed in the allotted time.

11.3.3.3 A/D Conversion Phases

The A/D conversion is based on two conversion phases:

- Sample capacitor loading [duration: t_{SAMPLE}]
During this phase, the V_{AIN} input voltage to be measured is loaded into the C_{ADC} sample capacitor.
- A/D conversion [duration: t_{HOLD}]
During this phase, the A/D conversion is computed (8 successive approximations cycles) and the C_{ADC} sample capacitor is disconnected from the analog input pin to get the optimum analog to digital conversion accuracy.
- The total conversion time:
 $t_{CONV} = t_{SAMPLE} + t_{HOLD}$

While the ADC is on, these two phases are continuously repeated.

At the end of each conversion, the sample capacitor is kept loaded with the previous measurement load. The advantage of this behaviour is that it minimizes the current consumption on the analog pin in case of single input channel measurement.

11.3.3.4 A/D Conversion

The analog input ports must be configured as input, no pull-up, no interrupt. Refer to the "I/O ports" chapter. Using these pins as analog inputs does not affect the ability of the port to be read as a logic input.

In the ADCCSR register:

- Select the CS[2:0] bits to assign the analog channel to convert.

ADC Conversion mode

In the ADCCSR register:

Set the ADON bit to enable the A/D converter and to start the conversion. From this time on, the ADC performs a continuous conversion of the selected channel.

When a conversion is complete:

- The EOC bit is set by hardware.
- The result is in the ADCDR registers.

A read to the ADCDRH or a write to any bit of the ADCCSR register resets the EOC bit.

To read the 10 bits, perform the following steps:

1. Poll EOC bit
2. Read ADCDRL
3. Read ADCDRH. This clears EOC automatically.

To read only 8 bits, perform the following steps:

1. Poll EOC bit
2. Read ADCDRH. This clears EOC automatically.

11.3.3.5 Changing the conversion channel

The application can change channels during conversion.

When software modifies the CH[2:0] bits in the ADCCSR register, the current conversion is stopped, the EOC bit is cleared, and the A/D converter starts converting the newly selected channel.

11.3.4 Low Power Modes

Note: The A/D converter may be disabled by resetting the ADON bit. This feature allows reduced power consumption when no conversion is needed and between single shot conversions.

| Mode | Description |
|------|---|
| WAIT | No effect on A/D Converter |
| HALT | A/D Converter disabled. After wakeup from Halt mode, the A/D Converter requires a stabilization time t_{STAB} (see Electrical Characteristics) before accurate conversions can be performed. |

11.3.5 Interrupts

None.

10-BIT A/D CONVERTER (ADC) (Cont'd)

11.3.6 Register Description

CONTROL/STATUS REGISTER (ADCCSR)

Read/Write (Except bit 7 read only)

Reset Value: 0000 0000 (00h)

| | | | | | | | |
|-----|-------|------|---|---|-----|-----|-----|
| 7 | | | | | | | 0 |
| EOC | SPEED | ADON | 0 | 0 | CH2 | CH1 | CH0 |

Bit 7 = **EOC** *End of Conversion*

This bit is set by hardware. It is cleared by hardware when software reads the ADCDRH register or writes to any bit of the ADCCSR register.

- 0: Conversion is not complete
- 1: Conversion complete

Bit 6 = **SPEED** *ADC clock selection*

This bit is set and cleared by software. It is used together with the SLOW bit to configure the ADC clock speed. Refer to the table in the SLOW bit description.

Bit 5 = **ADON** *A/D Converter on*

- This bit is set and cleared by software.
- 0: A/D converter is switched off
- 1: A/D converter is switched on

Bits 4:3 = **Reserved**. Must be kept cleared.

Bits 2:0 = **CH[2:0]** *Channel Selection*

These bits are set and cleared by software. They select the analog input to convert.

| Channel Pin | CH2 | CH1 | CH0 |
|-------------|-----|-----|-----|
| AIN0 | 0 | 0 | 0 |
| AIN1 | 0 | 0 | 1 |
| AIN2 | 0 | 1 | 0 |
| AIN3 | 0 | 1 | 1 |
| AIN4 | 1 | 0 | 0 |

Note: A write to the ADCCSR register (with ADON set) aborts the current conversion, resets the EOC bit and starts a new conversion.

DATA REGISTER HIGH (ADCDRH)

Read Only

Reset Value: 0000 0000 (00h)

| | | | | | | | |
|----|----|----|----|----|----|----|----|
| 7 | | | | | | | 0 |
| D9 | D8 | D7 | D6 | D5 | D4 | D3 | D2 |

Bits 7:0 = **D[9:2]** *MSB of Analog Converted Value*

DATA REGISTER LOW (ADCDRL)

Read/Write

Reset Value: 0000 0000 (00h)

| | | | | | | | |
|---|---|---|---|------|---|----|----|
| 7 | | | | | | | 0 |
| 0 | 0 | 0 | 0 | SLOW | 0 | D1 | D0 |

Bits 7:5 = **Reserved**. Forced by hardware to 0.

Bit 4 = **Reserved**. Forced by hardware to 0.

Bit 3 = **SLOW** *Slow mode*

This bit is set and cleared by software. It is used together with the SPEED bit to configure the ADC clock speed as shown on the table below.

| f_{ADC} | SLOW | SPEED |
|-------------|------|-------|
| $f_{CPU}/2$ | 0 | 0 |
| f_{CPU} | 0 | 1 |
| $f_{CPU}/4$ | 1 | x |

Bit 2 = **Reserved**. Forced by hardware to 0.

Bits 1:0 = **D[1:0]** *LSB of Analog Converted Value*

Table 21. ADC Register Map and Reset Values

| Address (Hex.) | Register Label | 7 | 6 | 5 | 4 | 3 | 2 | 1 | 0 |
|-------------------|------------------------------|----------|------------|-----------|---------|-----------|----------|----------|----------|
| 0034h | ADCCSR Reset Value | EOC 0 | SPEED 0 | ADON 0 | 0 0 | 0 0 | CH2 0 | CH1 0 | CH0 0 |
| 0035h | ADCDRH Reset Value | D9 0 | D8 0 | D7 0 | D6 0 | D5 0 | D4 0 | D3 0 | D2 0 |
| 0036h | ADCDRL Reset Value | 0 0 | 0 0 | 0 0 | 0 0 | SLOW 0 | 0 0 | D1 0 | D0 0 |

12 INSTRUCTION SET

12.1 ST7 ADDRESSING MODES

The ST7 Core features 17 different addressing modes which can be classified in seven main groups:

| Addressing Mode | Example |
|-----------------|-----------------|
| Inherent | nop |
| Immediate | ld A,#\$55 |
| Direct | ld A,\$55 |
| Indexed | ld A,(\$55,X) |
| Indirect | ld A,([\$55],X) |
| Relative | jrne loop |
| Bit operation | bset byte,#5 |

The ST7 Instruction set is designed to minimize the number of bytes required per instruction: To do so, most of the addressing modes may be subdivided in two submodes called long and short:

- Long addressing mode is more powerful because it can use the full 64 Kbyte address space, however it uses more bytes and more CPU cycles.
- Short addressing mode is less powerful because it can generally only access page zero (0000h - 00FFh range), but the instruction size is more compact, and faster. All memory to memory instructions use short addressing modes only (CLR, CPL, NEG, BSET, BRES, BTJT, BTJF, INC, DEC, RLC, RRC, SLL, SRL, SRA, SWAP)

The ST7 Assembler optimizes the use of long and short addressing modes.

Table 22. ST7 Addressing Mode Overview

| Mode | | | Syntax | Destination/ Source | Pointer Address (Hex.) | Pointer Size (Hex.) | Length (Bytes) |
|-----------|----------|----------|---------------------|-----------------------------|------------------------------|---------------------------|--|
| Inherent | | | nop | | | | + 0 |
| Immediate | | | ld A,#\$55 | | | | + 1 |
| Short | Direct | | ld A,\$10 | 00..FF | | | + 1 |
| Long | Direct | | ld A,\$1000 | 0000..FFFF | | | + 2 |
| No Offset | Direct | Indexed | ld A,(X) | 00..FF | | | + 0 (with X register) + 1 (with Y register) |
| Short | Direct | Indexed | ld A,(\$10,X) | 00..1FE | | | + 1 |
| Long | Direct | Indexed | ld A,(\$1000,X) | 0000..FFFF | | | + 2 |
| Short | Indirect | | ld A,[\$10] | 00..FF | 00..FF | byte | + 2 |
| Long | Indirect | | ld A,[\$10.w] | 0000..FFFF | 00..FF | word | + 2 |
| Short | Indirect | Indexed | ld A,([\$10],X) | 00..1FE | 00..FF | byte | + 2 |
| Long | Indirect | Indexed | ld A,([\$10.w],X) | 0000..FFFF | 00..FF | word | + 2 |
| Relative | Direct | | jrne loop | PC-128/PC+127 ¹⁾ | | | + 1 |
| Relative | Indirect | | jrne [\$10] | PC-128/PC+127 ¹⁾ | 00..FF | byte | + 2 |
| Bit | Direct | | bset \$10,#7 | 00..FF | | | + 1 |
| Bit | Indirect | | bset [\$10],#7 | 00..FF | 00..FF | byte | + 2 |
| Bit | Direct | Relative | btjt \$10,#7,skip | 00..FF | | | + 2 |
| Bit | Indirect | Relative | btjt [\$10],#7,skip | 00..FF | 00..FF | byte | + 3 |

Note:

1. At the time the instruction is executed, the Program Counter (PC) points to the instruction following JRxx.

ST7 ADDRESSING MODES (cont'd)

12.1.1 Inherent

All Inherent instructions consist of a single byte. The opcode fully specifies all the required information for the CPU to process the operation.

| Inherent Instruction | Function |
|-------------------------|-------------------------------------|
| NOP | No operation |
| TRAP | S/W Interrupt |
| WFI | Wait For Interrupt (Low Power Mode) |
| HALT | Halt Oscillator (Lowest Power Mode) |
| RET | Subroutine Return |
| IRET | Interrupt Subroutine Return |
| SIM | Set Interrupt Mask |
| RIM | Reset Interrupt Mask |
| SCF | Set Carry Flag |
| RCF | Reset Carry Flag |
| RSP | Reset Stack Pointer |
| LD | Load |
| CLR | Clear |
| PUSH/POP | Push/Pop to/from the stack |
| INC/DEC | Increment/Decrement |
| TNZ | Test Negative or Zero |
| CPL, NEG | 1 or 2 Complement |
| MUL | Byte Multiplication |
| SLL, SRL, SRA, RLC, RRC | Shift and Rotate Operations |
| SWAP | Swap Nibbles |

12.1.2 Immediate

Immediate instructions have 2 bytes, the first byte contains the opcode, the second byte contains the operand value.

| Immediate Instruction | Function |
|-----------------------|-----------------------|
| LD | Load |
| CP | Compare |
| BCP | Bit Compare |
| AND, OR, XOR | Logical Operations |
| ADC, ADD, SUB, SBC | Arithmetic Operations |

12.1.3 Direct

In Direct instructions, the operands are referenced by their memory address.

The direct addressing mode consists of two sub-modes:

Direct (Short)

The address is a byte, thus requires only 1 byte after the opcode, but only allows 00 - FF addressing space.

Direct (Long)

The address is a word, thus allowing 64 Kbyte addressing space, but requires 2 bytes after the opcode.

12.1.4 Indexed (No Offset, Short, Long)

In this mode, the operand is referenced by its memory address, which is defined by the unsigned addition of an index register (X or Y) with an offset.

The indirect addressing mode consists of three submodes:

Indexed (No Offset)

There is no offset (no extra byte after the opcode), and allows 00 - FF addressing space.

Indexed (Short)

The offset is a byte, thus requires only 1 byte after the opcode and allows 00 - 1FE addressing space.

Indexed (Long)

The offset is a word, thus allowing 64 Kbyte addressing space and requires 2 bytes after the opcode.

12.1.5 Indirect (Short, Long)

The required data byte to do the operation is found by its memory address, located in memory (pointer).

The pointer address follows the opcode. The indirect addressing mode consists of two submodes:

Indirect (Short)

The pointer address is a byte, the pointer size is a byte, thus allowing 00 - FF addressing space, and requires 1 byte after the opcode.

Indirect (Long)

The pointer address is a byte, the pointer size is a word, thus allowing 64 Kbyte addressing space, and requires 1 byte after the opcode.

ST7 ADDRESSING MODES (cont'd)**12.1.6 Indirect Indexed (Short, Long)**

This is a combination of indirect and short indexed addressing modes. The operand is referenced by its memory address, which is defined by the unsigned addition of an index register value (X or Y) with a pointer value located in memory. The pointer address follows the opcode.

The indirect indexed addressing mode consists of two submodes:

Indirect Indexed (Short)

The pointer address is a byte, the pointer size is a byte, thus allowing 00 - 1FE addressing space, and requires 1 byte after the opcode.

Indirect Indexed (Long)

The pointer address is a byte, the pointer size is a word, thus allowing 64 Kbyte addressing space, and requires 1 byte after the opcode.

Table 23. Instructions Supporting Direct, Indexed, Indirect and Indirect Indexed Addressing Modes

| Long and Short Instructions | Function |
|-----------------------------|--|
| LD | Load |
| CP | Compare |
| AND, OR, XOR | Logical Operations |
| ADC, ADD, SUB, SBC | Arithmetic Addition/subtraction operations |
| BCP | Bit Compare |

| Short Instructions Only | Function |
|-------------------------|------------------------------|
| CLR | Clear |
| INC, DEC | Increment/Decrement |
| TNZ | Test Negative or Zero |
| CPL, NEG | 1 or 2 Complement |
| BSET, BRES | Bit Operations |
| BTJT, BTJF | Bit Test and Jump Operations |
| SLL, SRL, SRA, RLC, RRC | Shift and Rotate Operations |
| SWAP | Swap Nibbles |
| CALL, JP | Call or Jump subroutine |

12.1.7 Relative Mode (Direct, Indirect)

This addressing mode is used to modify the PC register value by adding an 8-bit signed offset to it.

| Available Relative Direct/Indirect Instructions | Function |
|---|------------------|
| JRxx | Conditional Jump |
| CALLR | Call Relative |

The relative addressing mode consists of two submodes:

Relative (Direct)

The offset follows the opcode.

Relative (Indirect)

The offset is defined in memory, of which the address follows the opcode.

12.2 INSTRUCTION GROUPS

The ST7 family devices use an Instruction Set consisting of 63 instructions. The instructions may

be subdivided into 13 main groups as illustrated in the following table:

| | | | | | | | | |
|----------------------------------|------|------|------|------|------|-------|-----|-----|
| Load and Transfer | LD | CLR | | | | | | |
| Stack operation | PUSH | POP | RSP | | | | | |
| Increment/Decrement | INC | DEC | | | | | | |
| Compare and Tests | CP | TNZ | BCP | | | | | |
| Logical operations | AND | OR | XOR | CPL | NEG | | | |
| Bit Operation | BSET | BRES | | | | | | |
| Conditional Bit Test and Branch | BTJT | BTJF | | | | | | |
| Arithmetic operations | ADC | ADD | SUB | SBC | MUL | | | |
| Shift and Rotates | SLL | SRL | SRA | RLC | RRC | SWAP | SLA | |
| Unconditional Jump or Call | JRA | JRT | JRF | JP | CALL | CALLR | NOP | RET |
| Conditional Branch | JRxx | | | | | | | |
| Interrupt management | TRAP | WFI | HALT | IRET | | | | |
| Condition Code Flag modification | SIM | RIM | SCF | RCF | | | | |

Using a prebyte

The instructions are described with 1 to 4 bytes.

In order to extend the number of available opcodes for an 8-bit CPU (256 opcodes), three different prebyte opcodes are defined. These prebytes modify the meaning of the instruction they precede.

The whole instruction becomes:

- PC-2 End of previous instruction
- PC-1 Prebyte
- PC Opcode
- PC+1 Additional word (0 to 2) according to the number of bytes required to compute the effective address

These prebytes enable instruction in Y as well as indirect addressing modes to be implemented. They precede the opcode of the instruction in X or the instruction using direct addressing mode. The prebytes are:

PDY 90 Replace an X based instruction using immediate, direct, indexed, or inherent addressing mode by a Y one.

PIX 92 Replace an instruction using direct, direct bit or direct relative addressing mode to an instruction using the corresponding indirect addressing mode. It also changes an instruction using X indexed addressing mode to an instruction using indirect X indexed addressing mode.

PIY 91 Replace an instruction using X indirect indexed addressing mode by a Y one.

12.2.1 Illegal Opcode Reset

In order to provide enhanced robustness to the device against unexpected behavior, a system of illegal opcode detection is implemented. If a code to be executed does not correspond to any opcode or prebyte value, a reset is generated. This, combined with the Watchdog, allows the detection and recovery from an unexpected fault or interference.

Note: A valid prebyte associated with a valid opcode forming an unauthorized combination does not generate a reset.

INSTRUCTION GROUPS (cont'd)

| Mnemo | Description | Function/Example | Dst | Src | H | I | N | Z | C |
|-------|----------------------------|---------------------|--------|-----|---|---|---|---|---|
| ADC | Add with Carry | A = A + M + C | A | M | H | | N | Z | C |
| ADD | Addition | A = A + M | A | M | H | | N | Z | C |
| AND | Logical And | A = A . M | A | M | | | N | Z | |
| BCP | Bit compare A, Memory | tst (A . M) | A | M | | | N | Z | |
| BRES | Bit Reset | bres Byte, #3 | M | | | | | | |
| BSET | Bit Set | bset Byte, #3 | M | | | | | | |
| BTJF | Jump if bit is false (0) | btjf Byte, #3, Jmp1 | M | | | | | | C |
| BTJT | Jump if bit is true (1) | btjt Byte, #3, Jmp1 | M | | | | | | C |
| CALL | Call subroutine | | | | | | | | |
| CALLR | Call subroutine relative | | | | | | | | |
| CLR | Clear | | reg, M | | | | 0 | 1 | |
| CP | Arithmetic Compare | tst(Reg - M) | reg | M | | | N | Z | C |
| CPL | One Complement | A = FFH-A | reg, M | | | | N | Z | 1 |
| DEC | Decrement | dec Y | reg, M | | | | N | Z | |
| HALT | Halt | | | | | 0 | | | |
| IRET | Interrupt routine return | Pop CC, A, X, PC | | | H | I | N | Z | C |
| INC | Increment | inc X | reg, M | | | | N | Z | |
| JP | Absolute Jump | jp [TBL.w] | | | | | | | |
| JRA | Jump relative always | | | | | | | | |
| JRT | Jump relative | | | | | | | | |
| JRF | Never jump | jrf * | | | | | | | |
| JRIH | Jump if ext. interrupt = 1 | | | | | | | | |
| JRIL | Jump if ext. interrupt = 0 | | | | | | | | |
| JRH | Jump if H = 1 | H = 1 ? | | | | | | | |
| JRNH | Jump if H = 0 | H = 0 ? | | | | | | | |
| JRM | Jump if I = 1 | I = 1 ? | | | | | | | |
| JRNM | Jump if I = 0 | I = 0 ? | | | | | | | |
| JRMI | Jump if N = 1 (minus) | N = 1 ? | | | | | | | |
| JRPL | Jump if N = 0 (plus) | N = 0 ? | | | | | | | |
| JREQ | Jump if Z = 1 (equal) | Z = 1 ? | | | | | | | |
| JRNE | Jump if Z = 0 (not equal) | Z = 0 ? | | | | | | | |
| JRC | Jump if C = 1 | C = 1 ? | | | | | | | |
| JRNC | Jump if C = 0 | C = 0 ? | | | | | | | |
| JRULT | Jump if C = 1 | Unsigned < | | | | | | | |
| JRUGE | Jump if C = 0 | Jmp if unsigned >= | | | | | | | |
| JRUGT | Jump if (C + Z = 0) | Unsigned > | | | | | | | |

INSTRUCTION GROUPS (cont'd)

| Mnemo | Description | Function/Example | Dst | Src | H | I | N | Z | C |
|-------|------------------------|-------------------------|-----------|---------|---|---|---|---|---|
| JRULE | Jump if (C + Z = 1) | Unsigned <= | | | | | | | |
| LD | Load | dst <= src | reg, M | M, reg | | | N | Z | |
| MUL | Multiply | X,A = X * A | A, X, Y | X, Y, A | 0 | | | | 0 |
| NEG | Negate (2's compl) | neg \$10 | reg, M | | | | N | Z | C |
| NOP | No Operation | | | | | | | | |
| OR | OR operation | A = A + M | A | M | | | N | Z | |
| POP | Pop from the Stack | pop reg pop CC | reg CC | M M | H | I | N | Z | C |
| PUSH | Push onto the Stack | push Y | M | reg, CC | | | | | |
| RCF | Reset carry flag | C = 0 | | | | | | | 0 |
| RET | Subroutine Return | | | | | | | | |
| RIM | Enable Interrupts | I = 0 | | | | 0 | | | |
| RLC | Rotate left true C | C <= Dst <= C | reg, M | | | | N | Z | C |
| RRC | Rotate right true C | C => Dst => C | reg, M | | | | N | Z | C |
| RSP | Reset Stack Pointer | S = Max allowed | | | | | | | |
| SBC | Subtract with Carry | A = A - M - C | A | M | | | N | Z | C |
| SCF | Set carry flag | C = 1 | | | | | | | 1 |
| SIM | Disable Interrupts | I = 1 | | | | 1 | | | |
| SLA | Shift left Arithmetic | C <= Dst <= 0 | reg, M | | | | N | Z | C |
| SLL | Shift left Logic | C <= Dst <= 0 | reg, M | | | | N | Z | C |
| SRL | Shift right Logic | 0 => Dst => C | reg, M | | | | 0 | Z | C |
| SRA | Shift right Arithmetic | Dst7 => Dst => C | reg, M | | | | N | Z | C |
| SUB | Subtraction | A = A - M | A | M | | | N | Z | C |
| SWAP | SWAP nibbles | Dst[7..4] <=> Dst[3..0] | reg, M | | | | N | Z | |
| TNZ | Test for Neg & Zero | tnz lbl1 | | | | | N | Z | |
| TRAP | S/W trap | S/W interrupt | | | | 1 | | | |
| WFI | Wait for Interrupt | | | | | 0 | | | |
| XOR | Exclusive OR | A = A XOR M | A | M | | | N | Z | |

13 ELECTRICAL CHARACTERISTICS

13.1 PARAMETER CONDITIONS

Unless otherwise specified, all voltages are referred to V_{SS} .

13.1.1 Minimum and Maximum values

Unless otherwise specified the minimum and maximum values are guaranteed in the worst conditions of ambient temperature, supply voltage and frequencies by tests in production on 100% of the devices with an ambient temperature at $T_A=25^\circ\text{C}$ and $T_A=T_{A\text{max}}$ (given by the selected temperature range).

Data based on characterization results, design simulation and/or technology characteristics are indicated in the table footnotes and are not tested in production. Based on characterization, the minimum and maximum values refer to sample tests and represent the mean value plus or minus three times the standard deviation ($\text{mean} \pm 3\sigma$).

13.1.2 Typical values

Unless otherwise specified, typical data are based on $T_A=25^\circ\text{C}$, $V_{DD}=5\text{V}$ (for the $4.5\text{V} \leq V_{DD} \leq 5.5\text{V}$ voltage range), $V_{DD}=3.75\text{V}$ (for the $3\text{V} \leq V_{DD} \leq 4.5\text{V}$ voltage range) and $V_{DD}=2.7\text{V}$ (for the $2.4\text{V} \leq V_{DD} \leq 3\text{V}$ voltage range). They are given only as design guidelines and are not tested.

13.1.3 Typical curves

Unless otherwise specified, all typical curves are given only as design guidelines and are not tested.

13.1.4 Loading capacitor

The loading conditions used for pin parameter measurement are shown in [Figure 41](#).

Figure 41. Pin loading conditions

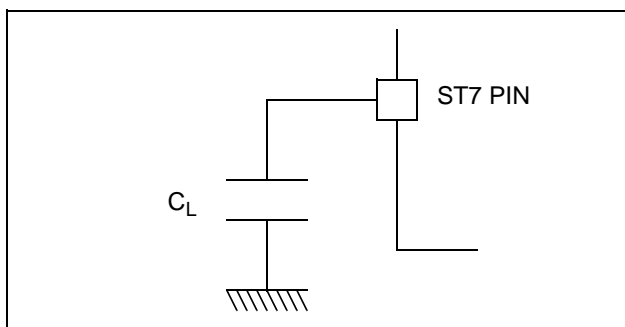

13.1.5 Pin input voltage

The input voltage measurement on a pin of the device is described in [Figure 42](#).

Figure 42. Pin input voltage

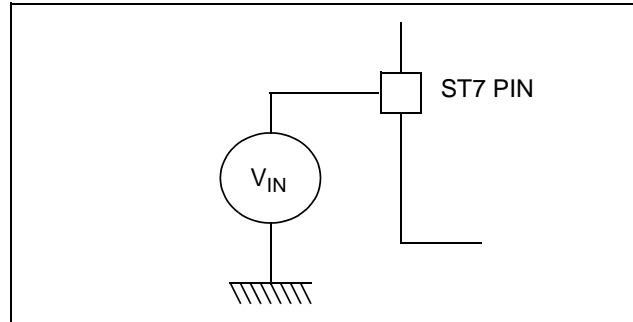

13.2 ABSOLUTE MAXIMUM RATINGS

Stresses above those listed as “absolute maximum ratings” may cause permanent damage to the device. This is a stress rating only and functional operation of the device under these condi-

tions is not implied. Exposure to maximum rating conditions for extended periods may affect device reliability.

13.2.1 Voltage Characteristics

| Symbol | Ratings | Maximum value | Unit |
|-------------------|--|---|------|
| $V_{DD} - V_{SS}$ | Supply voltage | 7.0 | V |
| V_{IN} | Input voltage on any pin ^{1) & 2)} | $V_{SS}-0.3$ to $V_{DD}+0.3$ | |
| $V_{ESD(HBM)}$ | Electrostatic discharge voltage (Human Body Model) | see section 13.7.2 on page 88 | |
| $V_{ESD(MM)}$ | Electrostatic discharge voltage (Machine Model) | see section 13.7.2 on page 88 | |

13.2.2 Current Characteristics

| Symbol | Ratings | Maximum value | Unit |
|----------------------------|--|---------------|------|
| I_{VDD} | Total current into V_{DD} power lines (source) ³⁾ | 75 | mA |
| I_{VSS} | Total current out of V_{SS} ground lines (sink) ³⁾ | 150 | |
| I_{IO} | Output current sunk by any standard I/O and control pin | 20 | |
| | Output current sunk by any high sink I/O pin | 40 | |
| | Output current source by any I/Os and control pin | -25 | |
| $I_{INJ(PIN)}^{2) \& 4)}$ | Injected current on \overline{RESET} pin | ± 5 | |
| | Injected current on any other pin ⁵⁾ | ± 5 | |
| $\Sigma I_{INJ(PIN)}^{2)}$ | Total injected current (sum of all I/O and control pins) ⁵⁾ | ± 20 | |

13.2.3 Thermal Characteristics

| Symbol | Ratings | Value | Unit |
|-----------|--|-------------|------|
| T_{STG} | Storage temperature range | -65 to +150 | °C |
| T_J | Maximum junction temperature (see Section PACKAGE CHARACTERISTICS (Cont'd)) | | |

Notes:

1. Directly connecting the I/O pins to V_{DD} or V_{SS} could damage the device if an unexpected change of the I/O configuration occurs (for example, due to a corrupted program counter). To guarantee safe operation, this connection has to be done through a pull-up or pull-down resistor (typical: 10k Ω for I/Os). Unused I/O pins must be tied in the same way to V_{DD} or V_{SS} according to their reset configuration.
2. $I_{INJ(PIN)}$ must never be exceeded. This is implicitly insured if V_{IN} maximum is respected. If V_{IN} maximum cannot be respected, the injection current must be limited externally to the $I_{INJ(PIN)}$ value. A positive injection is induced by $V_{IN} > V_{DD}$ while a negative injection is induced by $V_{IN} < V_{SS}$.
3. All power (V_{DD}) and ground (V_{SS}) lines must always be connected to the external supply.
4. Negative injection disturbs the analog performance of the device. In particular, it induces leakage currents throughout the device including the analog inputs. To avoid undesirable effects on the analog functions, care must be taken:
 - Analog input pins must have a negative injection less than 0.8 mA (assuming that the impedance of the analog voltage is lower than the specified limits)
 - Pure digital pins must have a negative injection less than 1.6mA. In addition, it is recommended to inject the current as far as possible from the analog input pins.
5. When several inputs are submitted to a current injection, the maximum $\Sigma I_{INJ(PIN)}$ is the absolute sum of the positive and negative injected currents (instantaneous values). These results are based on characterisation with $\Sigma I_{INJ(PIN)}$ maximum current injection on four I/O port pins of the device.

13.3 OPERATING CONDITIONS

13.3.1 General Operating Conditions

T_A = -40 to +125°C unless otherwise specified.

| Symbol | Parameter | Conditions | Min | Max | Unit |
|------------------|---------------------|--------------------------------|---------|-----|------|
| V _{DD} | Supply voltage | f _{CPU} = 4 MHz. max. | 2.4 | 5.5 | V |
| | | f _{CPU} = 8 MHz. max. | 3.3 | 5.5 | |
| f _{CPU} | CPU clock frequency | 3.3V ≤ V _{DD} ≤ 5.5V | up to 8 | | MHz |
| | | 2.4V ≤ V _{DD} < 3.3V | up to 4 | | |

Figure 43. f_{CPU} Maximum Operating Frequency Versus V_{DD} Supply Voltage

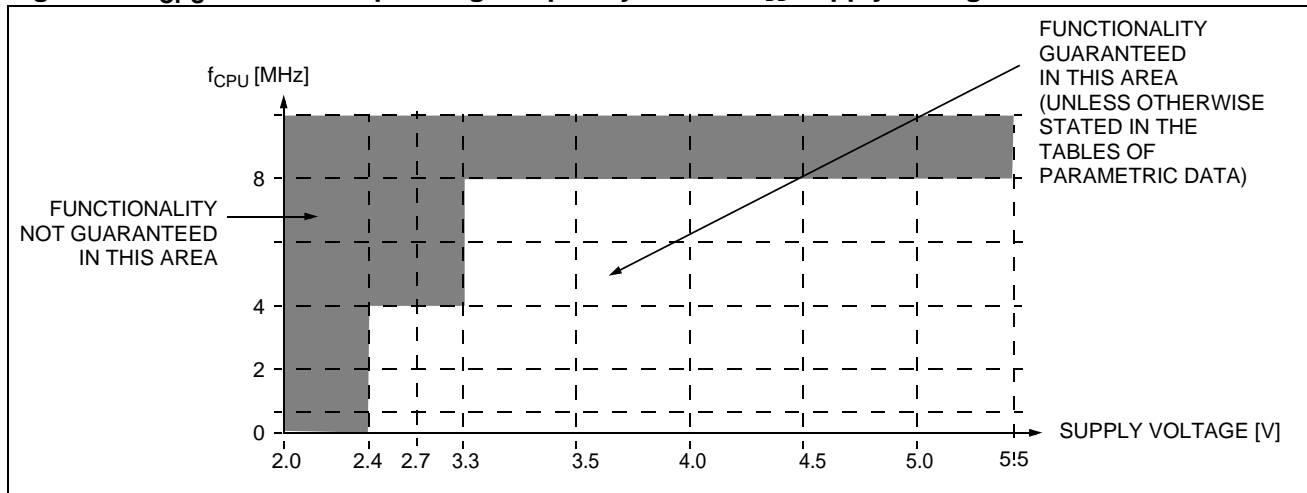

13.3.2 Operating Conditions with Low Voltage Detector (LVD)

$T_A = -40$ to 125°C , unless otherwise specified

| Symbol | Parameter | Conditions | Min | Typ | Max | Unit |
|--------------------|--|-------------------------------|-----|-----|-----|-----------------|
| $V_{IT+(LVD)}$ | Reset release threshold (V_{DD} rise) | High Threshold | 3.9 | 4.2 | 4.5 | V |
| | | Med. Threshold | 3.2 | 3.5 | 3.8 | |
| | | Low Threshold | 2.5 | 2.7 | 3.0 | |
| $V_{IT-(LVD)}$ | Reset generation threshold (V_{DD} fall) | High Threshold | 3.7 | 4.0 | 4.3 | V |
| | | Med. Threshold | 3.0 | 3.3 | 3.6 | |
| | | Low Threshold | 2.4 | 2.6 | 2.9 | |
| V_{hys} | LVD voltage threshold hysteresis | $V_{IT+(LVD)} - V_{IT-(LVD)}$ | | 150 | | mV |
| V_{tPOR} | V_{DD} rise time rate ^{2) 3)} | | 20 | | | $\mu\text{s/V}$ |
| $I_{DD(LVD)}^{1)}$ | LVD/AVD current consumption | $V_{DD} = 5V$ | | 220 | | μA |

Notes:

1. Not tested in production.
2. Not tested in production. The V_{DD} rise time rate condition is needed to ensure a correct device power-on and LVD reset release. When the V_{DD} slope is outside these values, the LVD may not release properly the reset of the MCU.
3. Use of LVD with capacitive power supply: with this type of power supply, if power cuts occur in the application, it is recommended to pull V_{DD} down to 0V to ensure optimum restart conditions. Refer to circuit example in [Figure 66 on page 97](#).

13.3.3 Auxiliary Voltage Detector (AVD) Thresholds

$T_A = -40$ to 125°C , unless otherwise specified

| Symbol | Parameter | Conditions | Min ¹⁾ | Typ ¹⁾ | Max ¹⁾ | Unit |
|----------------|---|-------------------------------|-------------------|-------------------|-------------------|------|
| $V_{IT+(AVD)}$ | 1=>0 AVDF flag toggle threshold (V_{DD} rise) | High Threshold | 4.0 | 4.4 | 4.8 | V |
| | | Med. Threshold | 3.4 | 3.7 | 4.1 | |
| | | Low Threshold | 2.6 | 2.9 | 3.2 | |
| $V_{IT-(AVD)}$ | 0=>1 AVDF flag toggle threshold (V_{DD} fall) | High Threshold | 3.9 | 4.3 | 4.7 | V |
| | | Med. Threshold | 3.3 | 3.6 | 4.0 | |
| | | Low Threshold | 2.5 | 2.8 | 3.1 | |
| V_{hys} | AVD voltage threshold hysteresis | $V_{IT+(AVD)} - V_{IT-(AVD)}$ | | 150 | | mV |

Note:

1. Not tested in production, guaranteed by characterization.

Note: Refer to [section 8.4.2.1 on page 35](#)

OPERATING CONDITIONS (Cont'd)

13.3.4 Voltage drop between AVD flag set and LVD reset generation

| Parameter | Min ¹⁾ | Typ ¹⁾ | Max ¹⁾ | Unit |
|--|-------------------|-------------------|-------------------|------|
| AVD med. Threshold - AVD low. threshold | 800 | 850 | 950 | mV |
| AVD high. Threshold - AVD low threshold | 1400 | 1450 | 1550 | |
| AVD high. Threshold - AVD med. threshold | 600 | 650 | 750 | |
| AVD low Threshold - LVD low threshold | 100 | 200 | 250 | |
| AVD med. Threshold - LVD low threshold | 950 | 1050 | 1150 | |
| AVD med. Threshold - LVD med. threshold | 250 | 300 | 400 | |
| AVD high. Threshold - LVD low threshold | 1600 | 1700 | 1800 | |
| AVD high. Threshold - LVD med. threshold | 900 | 1000 | 1050 | |

Note:

1. Not tested in production, guaranteed by characterization.

13.3.5 Internal RC oscillator

To improve clock stability and frequency accuracy, it is recommended to place a decoupling capacitor, typically 100nF, between the V_{DD} and V_{SS} pins as close as possible to the ST7 device

13.3.5.1 Internal RC oscillator calibrated at 5.0V

The ST7 internal clock can be supplied by an internal RC oscillator (selectable by option byte).

| Symbol | Parameter | Conditions | Min | Typ | Max | Unit |
|-------------------|---|--|------|-----------------|------|---------------|
| f_{RC} | Internal RC oscillator frequency | RCCR = FF (reset value), $T_A=25^\circ\text{C}, V_{DD}=5\text{V}$ | | 4.4 | | MHz |
| | | RCCR = RCCR0 ¹⁾ , $T_A=25^\circ\text{C}, V_{DD}=5\text{V}$ | | 8 | | |
| ACC _{RC} | Accuracy of Internal RC oscillator with RCCR=RCCR0 ¹⁾ | $T_A=25^\circ\text{C}, V_{DD}=4.5 \text{ to } 5.5\text{V}^{2)}$ | -2.0 | | +2.0 | % |
| | | $T_A=0 \text{ to } +85^\circ\text{C}, V_{DD}=4.5 \text{ to } 5.5\text{V}^{2)}$ | -2.5 | | +4.0 | % |
| | | $T_A=0 \text{ to } +125^\circ\text{C}, V_{DD}=4.5 \text{ to } 5.5\text{V}^{2)}$ | -3.0 | | +5.0 | % |
| | | $T_A=-40^\circ\text{C} \text{ to } 0^\circ\text{C}, V_{DD}=4.5 \text{ to } 5.5\text{V}^{2)}$ | -4.0 | | +2.5 | % |
| $t_{su(RC)}$ | RC oscillator setup time | $T_A=25^\circ\text{C}, V_{DD}=5\text{V}$ | | 4 ²⁾ | | μs |

Notes:

1. See "INTERNAL RC OSCILLATOR ADJUSTMENT" on page 22
2. Tested in production at 5.0 V only

13.3.5.2 Internal RC oscillator calibrated at 3.3V

The ST7 internal clock can be supplied by an internal RC oscillator (selectable by option byte).

| Symbol | Parameter | Conditions | Min | Typ | Max | Unit |
|-------------------|---|--|------|-----------------|------|---------------|
| f_{RC} | Internal RC oscillator frequency | RCCR = FF (reset value), $T_A=25^\circ\text{C}, V_{DD}=3.3\text{V}$ | | 4.3 | | MHz |
| | | RCCR = RCCR1 ¹⁾ , $T_A=25^\circ\text{C}, V_{DD}=3.3\text{V}$ | | 8 | | |
| ACC _{RC} | Accuracy of Internal RC oscillator with RCCR=RCCR1 ¹⁾ | $T_A=25^\circ\text{C}, V_{DD}=3.0 \text{ to } 3.6\text{V}^{2)}$ | -1.0 | | +1.0 | % |
| | | $T_A=0 \text{ to } +85^\circ\text{C}, V_{DD}=3.0 \text{ to } 3.6\text{V}^{2)}$ | -2.5 | | +4.0 | % |
| | | $T_A=0 \text{ to } +125^\circ\text{C}, V_{DD}=3.0 \text{ to } 3.6\text{V}^{2)}$ | -3.0 | | +5.0 | % |
| | | $T_A=-40^\circ\text{C} \text{ to } 0^\circ\text{C}, V_{DD}=3.0 \text{ to } 3.6\text{V}^{2)}$ | -4.0 | | +2.5 | % |
| $t_{su(RC)}$ | RC oscillator setup time | $T_A=25^\circ\text{C}, V_{DD}=3.3\text{V}$ | | 4 ²⁾ | | μs |

Notes:

1. See "INTERNAL RC OSCILLATOR ADJUSTMENT" on page 22
2. Tested in production at 3.3 V only

Figure 44. Typical accuracy with RCCR=RCCR0 vs $V_{DD}=2.4\text{-}6.0\text{V}$ and Temperature

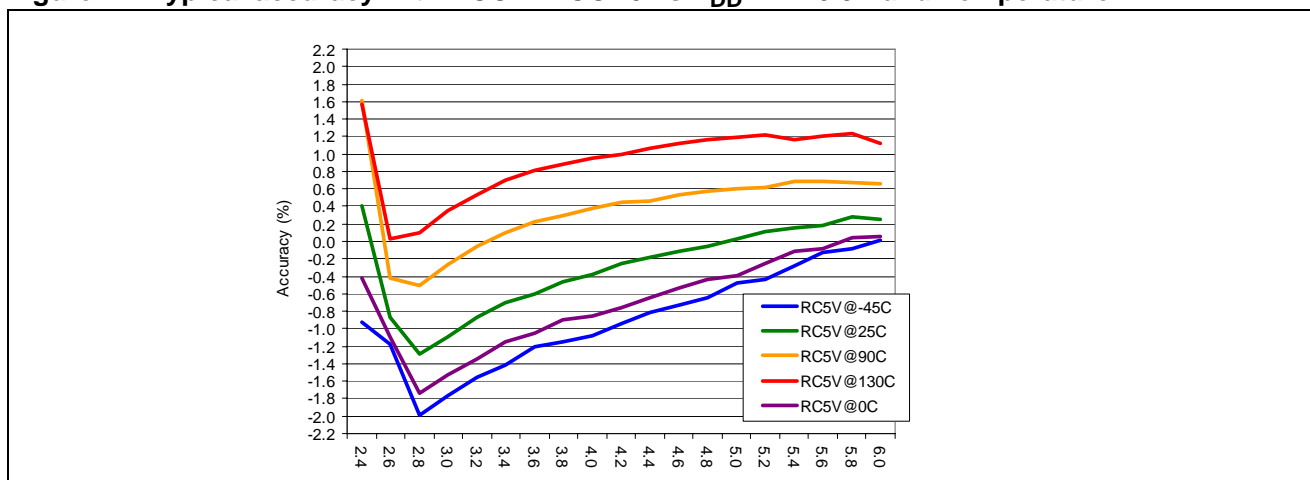
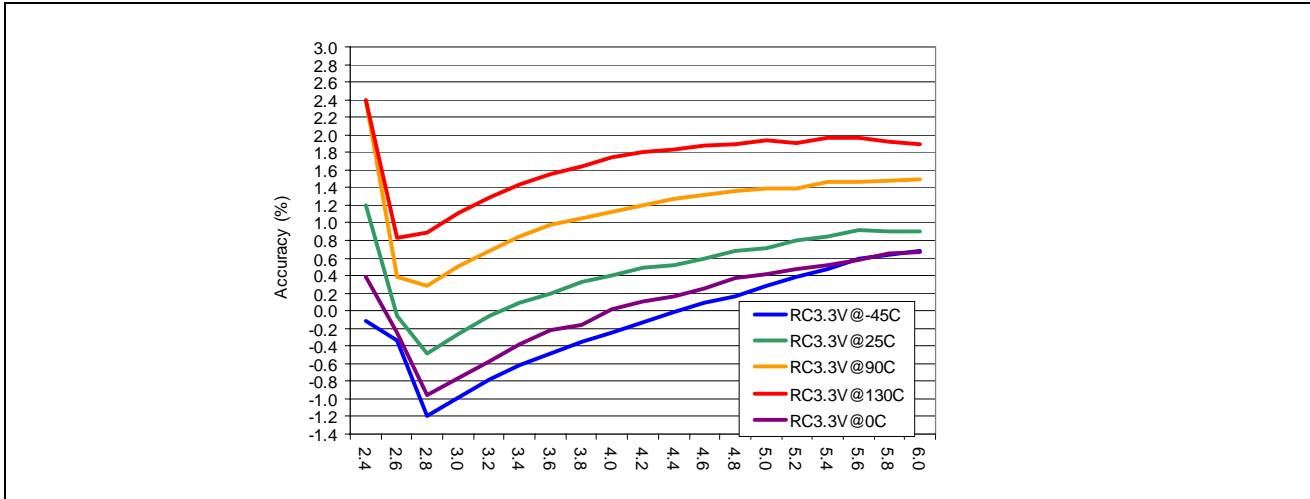

Figure 45. Typical accuracy with RCCR=RCCR1 vs V_{DD} = 2.4-6.0V and Temperature



13.4 SUPPLY CURRENT CHARACTERISTICS

The following current consumption specified for the ST7 functional operating modes over temperature range does not take into account the clock source current consumption. To get the total de-

vice consumption, the two current values must be added (except for HALT mode for which the clock is stopped). Refer to [Section 13.4.2 Internal RC oscillator supply characteristics](#).

13.4.1 Supply Current

$T_A = -40$ to $+125^\circ\text{C}$ unless otherwise specified

| Symbol | Parameter | Conditions | Typ | Max | Unit | |
|--|--|---------------------------|------------------------|-------------------|-------------------|---------------|
| I_{DD} | Supply current in RUN mode ¹⁾ | $f_{CPU} = 4$ MHz | 2.5 | 4.5 ⁸⁾ | mA | |
| | | $f_{CPU} = 8$ MHz | 5.0 | 7.5 | | |
| | Supply current in WAIT mode ²⁾ | $f_{CPU} = 4$ MHz | 0.85 | 2.0 ⁸⁾ | mA | |
| | | $f_{CPU} = 8$ MHz | 1.2 | 3.5 | | |
| | Supply current in SLOW mode ³⁾ | $f_{CPU}/32 = 250$ kHz | 600 | 950 | μA | |
| | Supply current in SLOW-WAIT mode ⁴⁾ | $f_{CPU}/32 = 250$ kHz | 450 | 750 | | |
| | Supply current in AWUFH mode ⁵⁾⁶⁾ | | 45 | 100 ⁸⁾ | | |
| | Supply current in ACTIVE HALT mode | | 100 | 250 | | |
| | Supply current in HALT mode ⁷⁾ | $T_A = 85^\circ\text{C}$ | 0.5 | 3.0 | | |
| | | $T_A = 125^\circ\text{C}$ | 0.5 | 5.0 | | |
| | Supply current in RUN mode ¹⁾ | $V_{DD} = 3\text{V}$ | $f_{CPU} = 4$ MHz | 1.30 | 2.0 ⁸⁾ | mA |
| | | | $f_{CPU} = 4$ MHz | 0.36 | 0.5 ⁸⁾ | |
| | Supply current in WAIT mode ²⁾ | $V_{DD} = 3\text{V}$ | $f_{CPU}/32 = 250$ kHz | 300 | 400 ⁸⁾ | μA |
| | | | $f_{CPU}/32 = 250$ kHz | 250 | 350 ⁸⁾ | |
| Supply current in SLOW mode ³⁾ | | | 20 | 50 ⁸⁾ | | |
| Supply current in SLOW-WAIT mode ⁴⁾ | | | 90 | 150 ⁸⁾ | | |
| Supply current in AWUFH mode ⁵⁾⁶⁾ | | | 0.25 | 2.5 ⁸⁾ | | |
| Supply current in ACTIVE HALT mode | | | 0.25 | 4.5 ⁸⁾ | | |

Notes:

- CPU running with memory access, all I/O pins in input mode with a static value at V_{DD} or V_{SS} (no load), all peripherals in reset state; clock input (CLKIN) driven by external square wave, LVD disabled.
- All I/O pins in input mode with a static value at V_{DD} or V_{SS} (no load), all peripherals in reset state; clock input (CLKIN) driven by external square wave, LVD disabled.
- SLOW mode selected with f_{CPU} based on f_{OSC} divided by 32. All I/O pins in input mode with a static value at V_{DD} or V_{SS} (no load), all peripherals in reset state; clock input (CLKIN) driven by external square wave, LVD disabled.
- SLOW-WAIT mode selected with f_{CPU} based on f_{OSC} divided by 32. All I/O pins in input mode with a static value at V_{DD} or V_{SS} (no load), all peripherals in reset state; clock input (CLKIN) driven by external square wave, LVD disabled.
- All I/O pins in input mode with a static value at V_{DD} or V_{SS} (no load). Data tested in production at V_{DD} max. and f_{CPU} max.
- This consumption refers to the Halt period only and not the associated run period which is software dependent.
- All I/O pins in output mode with a static value at V_{SS} (no load), LVD disabled. Data based on characterization results, tested in production at V_{DD} max and f_{CPU} max.
- Data based on characterization, not tested in production.

13.4.2 Internal RC oscillator supply characteristics

| Symbol | Parameter | Conditions | Min | Typ | Max ⁵⁾ | Unit | |
|------------------------------------|--|----------------------------------|---|------|-------------------|------|----|
| I _{DD} | Supply current in RUN mode ¹⁾ | RC oscillator calibrated at 5.0V | T _A =25°C, int RC = 4 MHz | | 3.2 | 5.5 | mA |
| | | | T _A =25°C, int RC = 8 MHz | | 5.7 | 8.5 | |
| | | | T _A =25°C, AWU RC | | 0.13 | 0.2 | |
| | Supply current in WAIT mode ²⁾ | | T _A =25°C, int RC = 4 MHz | | 1.5 | 3.0 | |
| | | | T _A =25°C, int RC = 8 MHz | | 1.9 | 4.5 | |
| | Supply current in SLOW mode ³⁾ | | T _A =25°C, int RC/32 = 250 kHz | | 1.3 | 2.0 | |
| | Supply current in SLOW-WAIT mode ⁴⁾ | | T _A =25°C, int RC/32 = 250 kHz | | 1.1 | 1.8 | |
| Supply current in ACTIVE HALT mode | | | 0.8 | 1.25 | | | |
| I _{DD} | Supply current in RUN mode ¹⁾ | RC oscillator calibrated at 3.3V | T _A =25°C, int RC = 4 MHz | | 2.0 | 3.0 | mA |
| | | | T _A =25°C, int RC = 2 MHz | | 1.3 | 2.0 | |
| | | | T _A =25°C, AWU RC | | 0.1 | 0.18 | |
| | Supply current in WAIT mode ²⁾ | | T _A =25°C, int RC = 4 MHz | | 1.0 | 1.6 | |
| | | | T _A =25°C, int RC = 2 MHz | | 0.9 | 1.5 | |
| | Supply current in SLOW mode ³⁾ | | T _A =25°C, int RC/32 = 250 kHz | | 0.95 | 1.5 | |
| | Supply current in SLOW-WAIT mode ⁴⁾ | | T _A =25°C, int RC/32 = 250 kHz | | 0.85 | 1.4 | |
| Supply current in ACTIVE HALT mode | | | 0.8 | 1.3 | | | |

Notes:

1. CPU running with memory access, all I/O pins in input mode with a static value at V_{DD} or V_{SS} (no load), all peripherals in reset state; CPU clock provided by the internal RC, LVD disabled.
2. All I/O pins in input mode with a static value at V_{DD} or V_{SS} (no load), all peripherals in reset state; CPU clock provided by the internal RC, LVD disabled.
3. SLOW mode selected with f_{CPU} based on f_{OSC} divided by 32. All I/O pins in input mode with a static value at V_{DD} or V_{SS} (no load), all peripherals in reset state; CPU clock provided by the internal RC, LVD disabled.
4. SLOW-WAIT mode selected with f_{CPU} based on f_{OSC} divided by 32. All I/O pins in input mode with a static value at V_{DD} or V_{SS} (no load), all peripherals in reset state; CPU clock provided by the internal RC, LVD disabled.
5. Data based on characterization results, not tested in production.

SUPPLY CURRENT CHARACTERISTICS (Cont'd)

Figure 46. Typical I_{DD} in run mode vs. internal clock frequency and V_{DD}

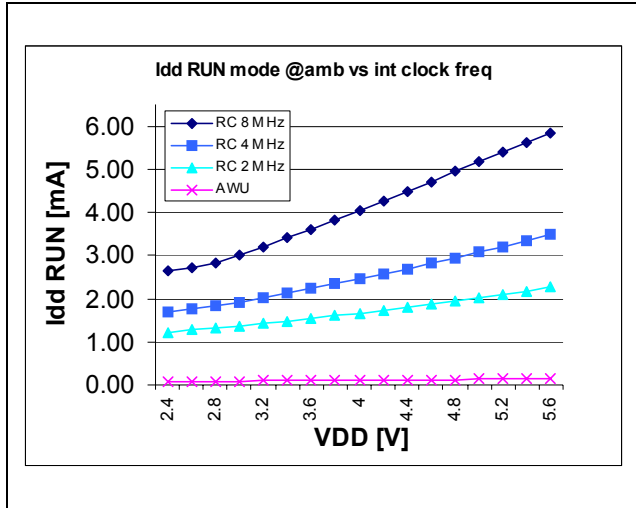

Figure 47. Typical I_{DD} in WFI mode vs. internal clock frequency and V_{DD}

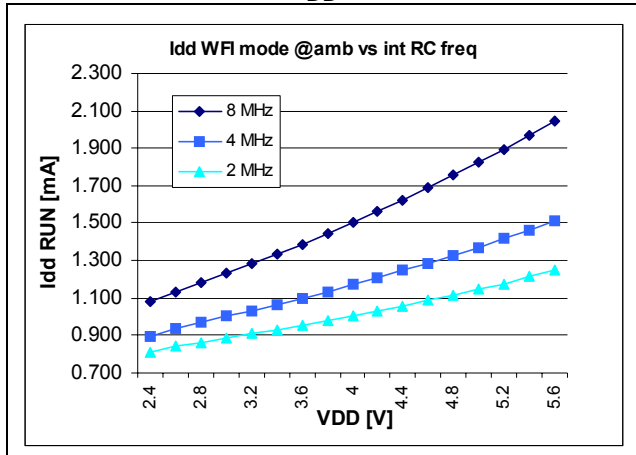

Figure 48. Typical I_{DD} in SLOW, SLOW-WAIT and Active-Halt mode vs V_{DD} & int RC=8MHz

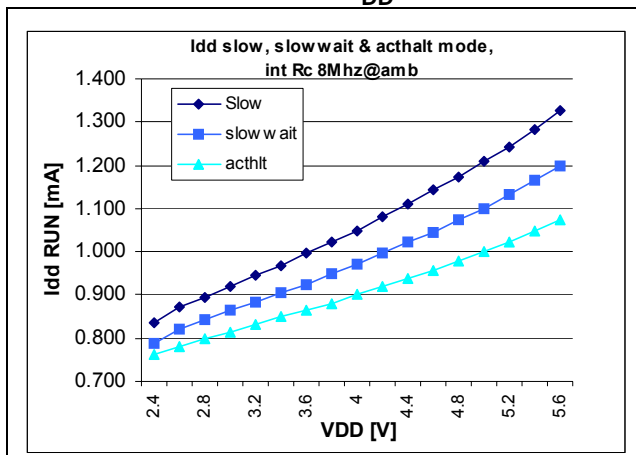

Figure 49. I_{DD} vs temp @Vdd 5V & int RC=8MHz

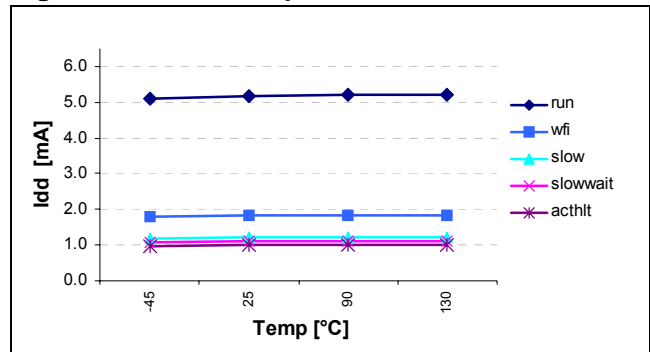

Figure 50. I_{DD} vs temp @Vdd 5V & int RC=4MHz

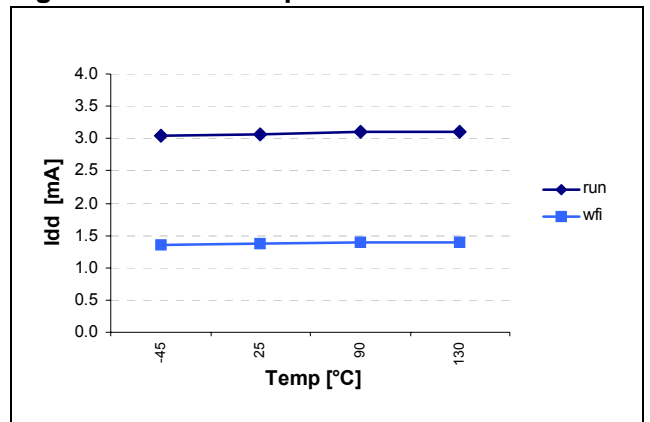
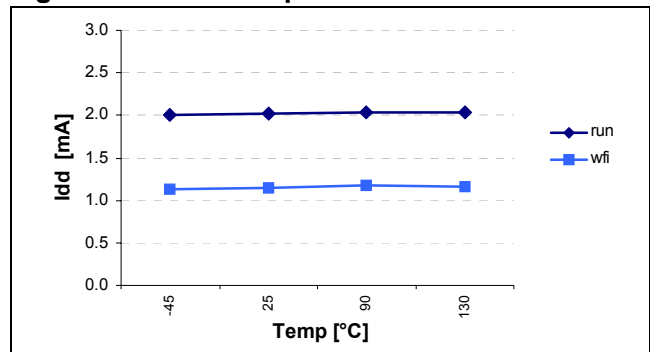

Figure 51. I_{DD} vs temp @Vdd 5V & int RC=2MHz



13.4.3 On-chip peripherals

| Symbol | Parameter | Conditions | | Typ ³⁾ | Unit |
|----------------------|---|------------------------|-----------------------|-------------------|------|
| I _{DD(AT)} | 12-bit Auto-Reload Timer supply current ¹⁾ | f _{CPU} =4MHz | V _{DD} =3.0V | 15 | μA |
| | | f _{CPU} =8MHz | V _{DD} =5.0V | 30 | |
| I _{DD(ADC)} | ADC supply current when converting ²⁾ | f _{ADC} =2MHz | V _{DD} =3.0V | 450 | |
| | | f _{ADC} =4MHz | V _{DD} =5.0V | 750 | |

Notes:

1. Data based on a differential I_{DD} measurement between reset configuration (timer stopped) and the timer running in PWM mode at f_{cpu}=8MHz.
2. Data based on a differential I_{DD} measurement between reset configuration and continuous A/D conversions with amplifier off.
3. Not tested in production, guaranteed by characterization.

13.5 CLOCK AND TIMING CHARACTERISTICS

Subject to general operating conditions for V_{DD} , f_{OSC} , and T_A .

13.5.1 General Timings

| Symbol | Parameter ¹⁾ | Conditions | Min | Typ ²⁾ | Max | Unit |
|---------------|--|----------------|------|-------------------|------|-----------|
| $t_{c(INST)}$ | Instruction cycle time | $f_{CPU}=8MHz$ | 2 | 3 | 12 | t_{CPU} |
| | | | 250 | 375 | 1500 | ns |
| $t_{V(IT)}$ | Interrupt reaction time ³⁾ $t_{V(IT)} = \Delta t_{c(INST)} + 10$ | $f_{CPU}=8MHz$ | 10 | | 22 | t_{CPU} |
| | | | 1.25 | | 2.75 | μs |

Notes:

1. Data based on characterization. Not tested in production.
2. Data based on typical application software.
3. Time measured between interrupt event and interrupt vector fetch. $\Delta t_{c(INST)}$ is the number of t_{CPU} cycles needed to finish the current instruction execution.

13.5.2 Auto Wakeup RC Oscillator

| Parameter | Conditions | Min | Typ | Max | Unit |
|--|---------------------|-----|-----|------|---------|
| Supply Voltage Range | | 2.4 | 5.0 | 5.5 | V |
| Operating Temperature Range | | -40 | 25 | 125 | °C |
| Current Consumption ¹⁾ | Without prescaler | 2.0 | 8.0 | 14.0 | μA |
| Consumption ¹⁾ | AWU RC switched off | | 0 | | μA |
| Output Frequency (f_{AWU_RC}) ¹⁾ | | 20 | 33 | 60 | kHz |

Note:

1. Data guaranteed by Design.

13.6 MEMORY CHARACTERISTICS

$T_A = -40^{\circ}\text{C}$ to 125°C , unless otherwise specified

13.6.1 RAM and Hardware Registers

| Symbol | Parameter | Conditions | Min | Typ | Max | Unit |
|----------|-----------------------------------|----------------------|-----|-----|-----|------|
| V_{RM} | Data retention mode ¹⁾ | HALT mode (or RESET) | 1.6 | | | V |

13.6.2 FLASH Program Memory

| Symbol | Parameter | Conditions | Min | Typ | Max | Unit |
|------------|---|---|-----|------|------|---------------|
| V_{DD} | Operating voltage for Flash write/erase | | 2.4 | | 5.5 | V |
| t_{prog} | Programming time for 1~32 bytes ²⁾ | $T_A = -40$ to $+125^{\circ}\text{C}$ | | 5 | 10 | ms |
| | Programming time for 2 KBytes | $T_A = +25^{\circ}\text{C}$ | | 0.32 | 0.64 | s |
| t_{RET} | Data retention ⁴⁾ | $T_A = +55^{\circ}\text{C}$ ³⁾ | 20 | | | years |
| N_{RW} | Write erase cycles | $T_A = +25^{\circ}\text{C}$ | | | 10k | cycles |
| I_{DD} | Supply current ⁶⁾ | Read / Write / Erase modes $f_{CPU} = 8\text{ MHz}$, $V_{DD} = 5.5\text{ V}$ | | | 2.6 | mA |
| | | No Read/No Write Mode | | | 100 | μA |
| | | Power down mode / HALT | | 0 | 0.1 | μA |

13.6.3 EEPROM Data Memory

| Symbol | Parameter | Conditions | Min | Typ | Max | Unit |
|------------|--|---|-----|-----|------|--------|
| V_{DD} | Operating voltage for EEPROM write/erase | Refer to operating range of V_{DD} with T_A , section 13.3.1 on page 76 | 2.4 | | 5.5 | V |
| t_{prog} | Programming time for 1~32 bytes | $T_A = -40$ to $+125^{\circ}\text{C}$ | | 5 | 10 | ms |
| t_{ret} | Data retention ⁴⁾ | $T_A = +55^{\circ}\text{C}$ ³⁾ | 20 | | | years |
| N_{RW} | Write erase cycles | $T_A = +25^{\circ}\text{C}$ | | | 300k | cycles |

Notes:

1. Minimum V_{DD} supply voltage without losing data stored in RAM (in HALT mode or under RESET) or in hardware registers (only in HALT mode). Guaranteed by construction, not tested in production.
2. Up to 32 bytes can be programmed at a time.
3. The data retention time increases when T_A decreases.
4. Data based on reliability test results and monitored in production.
5. Data based on characterization results, not tested in production.
6. Guaranteed by Design. Not tested in production.

13.7 EMC CHARACTERISTICS

Susceptibility tests are performed on a sample basis during product characterization.

13.7.1 Functional EMS (Electro Magnetic Susceptibility)

Based on a simple running application on the product (toggling 2 LEDs through I/O ports), the product is stressed by two electro magnetic events until a failure occurs (indicated by the LEDs).

- **ESD:** Electro-Static Discharge (positive and negative) is applied on all pins of the device until a functional disturbance occurs. This test conforms with the IEC 1000-4-2 standard.
- **FTB:** A Burst of Fast Transient voltage (positive and negative) is applied to V_{DD} and V_{SS} through a 100pF capacitor, until a functional disturbance occurs. This test conforms with the IEC 1000-4-4 standard.

A device reset allows normal operations to be resumed. The test results are given in the table below based on the EMS levels and classes defined in application note AN1709.

13.7.1.1 Designing hardened software to avoid noise problems

EMC characterization and optimization are performed at component level with a typical application environment and simplified MCU software. It

should be noted that good EMC performance is highly dependent on the user application and the software in particular.

Therefore it is recommended that the user applies EMC software optimization and prequalification tests in relation with the EMC level requested for his application.

Software recommendations:

The software flowchart must include the management of runaway conditions such as:

- Corrupted program counter
- Unexpected reset
- Critical Data corruption (control registers...)

Prequalification trials:

Most of the common failures (unexpected reset and program counter corruption) can be reproduced by manually forcing a low state on the RESET pin or the Oscillator pins for 1 second.

To complete these trials, ESD stress can be applied directly on the device, over the range of specification values. When unexpected behaviour is detected, the software can be hardened to prevent unrecoverable errors occurring (see application note AN1015).

| Symbol | Parameter | Conditions | Level/Class |
|------------|--|---|-------------|
| V_{FESD} | Voltage limits to be applied on any I/O pin to induce a functional disturbance | $V_{DD}=5V$, $T_A=+25^{\circ}C$, $f_{OSC}=8MHz$, SO8 package, conforms to IEC 1000-4-2 | 3B |
| V_{FFTB} | Fast transient voltage burst limits to be applied through 100pF on V_{SS} and V_{DD} pins to induce a functional disturbance | $V_{DD}=5V$, $T_A=+25^{\circ}C$, $f_{OSC}=8MHz$, SO8 package, conforms to IEC 1000-4-4 | 4A |

EMC CHARACTERISTICS (Cont'd)

13.7.2 Electro Magnetic Interference (EMI)

Based on a simple application running on the product (toggling 2 LEDs through the I/O ports), the product is monitored in terms of emission. This emission test is in line with the norm SAE J 1752/3 which specifies the board and the loading of each pin.

| Symbol | Parameter | Conditions | Monitored Frequency Band | Max vs. [f _{osc} /f _{cpu}] | Unit |
|------------------|------------|---|--------------------------|---|------------|
| | | | | -/8MHz | |
| S _{EMI} | Peak level | V _{DD} =5 V, T _A =+25 °C, SO8 package, conforming to SAE J 1752/3 | 0.1 MHz to 30 MHz | 20 | dB μ V |
| | | | 30 MHz to 130 MHz | 20 | |
| | | | 130 MHz to 1 GHz | 13 | |
| | | | SAE EMI Level | 2.5 | - |

Note:

1. Data based on characterization results, not tested in production.

13.7.3 Absolute Maximum Ratings (Electrical Sensitivity)

Based on three different tests (ESD, LU and DLU) using specific measurement methods, the product is stressed in order to determine its performance in terms of electrical sensitivity. For more details, refer to the application note AN1181.

13.7.3.1 Electro-Static Discharge (ESD)

Electro-Static Discharges (a positive then a negative pulse separated by 1 second) are applied to the pins of each sample according to each pin combination. The sample size depends on the number of supply pins in the device (3 parts*(n+1) supply pin). One model can be simulated: Human Body Model. This test conforms to the JESD22-A114A/A115A standard.

Absolute Maximum Ratings

| Symbol | Ratings | Conditions | Maximum value ¹⁾ | Unit |
|-----------------------|--|------------------------|-----------------------------|------|
| V _{ESD(HBM)} | Electro-static discharge voltage (Human Body Model) | | 4000 | V |
| V _{ESD(CDM)} | Electro-static discharge voltage (Charge Device Model) | T _A =+25 °C | 500 | V |

Note:

1. Data based on characterization results, not tested in production.

EMC CHARACTERISTICS (Cont'd)**13.7.3.2 Static and Dynamic Latch-Up**

- **LU:** 3 complementary static tests are required on 10 parts to assess the latch-up performance. A supply overvoltage (applied to each power supply pin) and a current injection (applied to each input, output and configurable I/O pin) are performed on each sample. This test conforms to the EIA/JESD 78 IC latch-up standard. For more details, refer to the application note AN1181.
- **DLU:** Electro-Static Discharges (one positive then one negative test) are applied to each pin of 3 samples when the micro is running to assess the latch-up performance in dynamic mode. Power supplies are set to the typical values, the oscillator is connected as near as possible to the pins of the micro and the component is put in reset mode. This test conforms to the IEC1000-4-2 and SAEJ1752/3 standards. For more details, refer to the application note AN1181.

Electrical Sensitivities

| Symbol | Parameter | Conditions | Class ¹⁾ |
|--------|------------------------|--|---------------------|
| LU | Static latch-up class | $T_A=+125^{\circ}\text{C}$ | A |
| DLU | Dynamic latch-up class | $V_{DD}=5.5\text{V}$, $f_{OSC}=4\text{MHz}$, $T_A=+25^{\circ}\text{C}$ | A |

Note:

1. Class description: A Class is an STMicroelectronics internal specification. All its limits are higher than the JEDEC specifications, that means when a device belongs to Class A it exceeds the JEDEC standard. B Class strictly covers all the JEDEC criteria (international standard).

13.8 I/O PORT PIN CHARACTERISTICS

13.8.1 General Characteristics

Subject to general operating conditions for V_{DD} , f_{OSC} , and T_A unless otherwise specified.

| Symbol | Parameter | Conditions | Min | Typ | Max | Unit |
|-----------------|---|-------------------------------------|---------------------|--------------------------|---------------------|------------|
| V_{IL} | Input low level voltage | -40°C to 125°C | | | $0.3 \times V_{DD}$ | V |
| V_{IH} | Input high level voltage | | $0.7 \times V_{DD}$ | | | |
| V_{HYS} | Schmitt trigger voltage hysteresis ¹⁾ | | | 400 | | mV |
| I_L | Input leakage current | $V_{SS} \leq V_{IN} \leq V_{DD}$ | | | ± 1 | μA |
| I_S | Static current consumption induced by each floating input pin ²⁾ | Floating input mode | | 400 | | |
| R_{PU} | Weak pull-up equivalent resistor ^{3) 5)} | $V_{IN} = V_{SS}$ | 70 | 110 200 ¹⁾ | 200 | k Ω |
| | | $V_{DD} = 5V$ $V_{DD} = 3V$ | | | | |
| C_{IO} | I/O pin capacitance | | | 5 | | pF |
| $t_{f(I/O)out}$ | Output high to low level fall time ¹⁾ | $C_L = 50pF$ Between 10% and 90% | | 25 | | ns |
| $t_{r(I/O)out}$ | Output low to high level rise time ¹⁾ | | | 25 | | |
| $t_{w(IT)in}$ | External interrupt pulse time ⁴⁾ | | 1 | | | t_{CPU} |

Notes:

1. Data based on characterization results, not tested in production.
2. Configuration not recommended, all unused pins must be kept at a fixed voltage: using the output mode of the I/O for example or an external pull-up or pull-down resistor (see [Figure 57](#)). Static peak current value taken at a fixed V_{IN} value, based on design simulation and technology characteristics, not tested in production. This value depends on V_{DD} and temperature values.
3. The R_{PU} pull-up equivalent resistor is based on a resistive transistor (corresponding I_{PU} current characteristics described in [Figure 54](#)).
4. To generate an external interrupt, a minimum pulse width has to be applied on an I/O port pin configured as an external interrupt source.
5. R_{PU} not applicable on PA3 because it is multiplexed on \overline{RESET} pin

Figure 52. Two typical Applications with unused I/O Pin

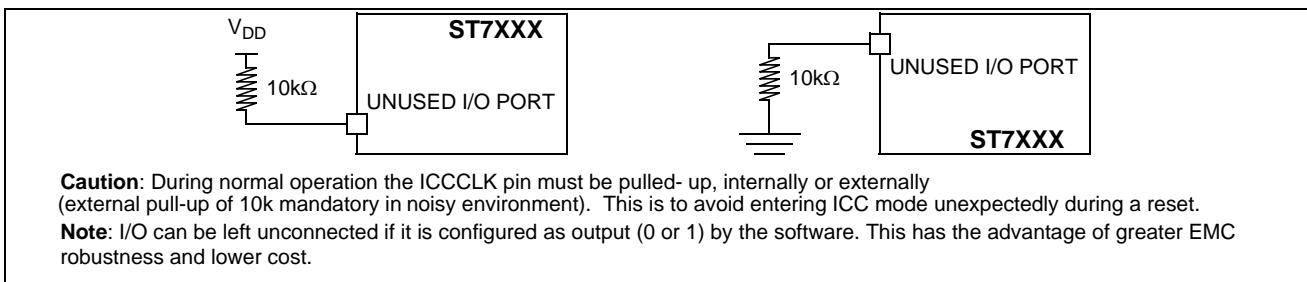

I/O PORT PIN CHARACTERISTICS (Cont'd)

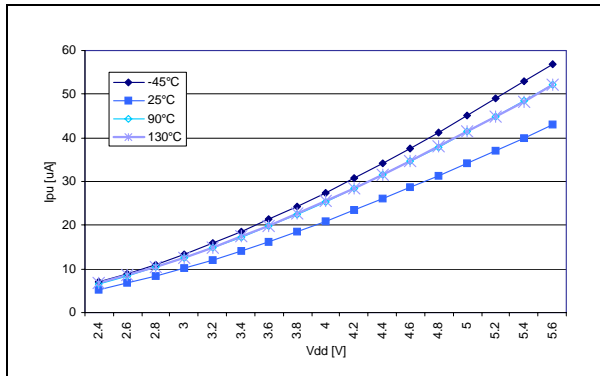
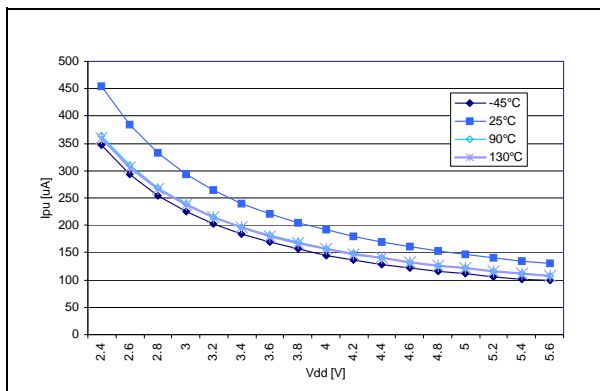
Figure 53. Typical I_{PU} vs. V_{DD} with $V_{IN}=V_{SS}$ Figure 54. Typical R_{PU} vs. V_{DD} with $V_{IN}=V_{SS}$ 

13.8.2 Output Driving Current

Subject to general operating conditions for V_{DD} , f_{CPU} , and T_A unless otherwise specified.

| Symbol | Parameter | Conditions | Min | Max | Unit |
|-----------------|--|--------------------------------------|---------------|------|------|
| $V_{OL}^{1)}$ | Output low level voltage for PA3/RESET standard I/O pin (see Figure 57) | $I_{IO}=+5mA, T_A \leq 125^\circ C$ | | 1200 | mV |
| | | $I_{IO}=+2mA, T_A \leq 125^\circ C$ | | 400 | |
| | Output low level voltage for a high sink I/O pin when 4 pins are sunk at same time (see Figure 60) | $I_{IO}=+20mA, T_A \leq 125^\circ C$ | | 1300 | |
| | | $I_{IO}=+8mA, T_A \leq 125^\circ C$ | | 750 | |
| $V_{OH}^{2)}$ | Output high level voltage for an I/O pin when 4 pins are sourced at same time (see Figure 63) | $I_{IO}=-5mA, T_A \leq 125^\circ C$ | $V_{DD}-1500$ | | |
| | | $I_{IO}=-2mA, T_A \leq 125^\circ C$ | $V_{DD}-800$ | | |
| $V_{OL}^{1)3)}$ | Output low level voltage for PA3/RESET standard I/O pin (see Figure 56) | $I_{IO}=+2mA, T_A \leq 125^\circ C$ | | 500 | |
| | | $I_{IO}=+2mA, T_A \leq 125^\circ C$ | | 180 | |
| | Output low level voltage for a high sink I/O pin when 4 pins are sunk at same time (see Figure 59) | $I_{IO}=+8mA, T_A \leq 125^\circ C$ | | 600 | |
| $V_{OH}^{2)3)}$ | Output high level voltage for an I/O pin when 4 pins are sourced at same time (see Figure 62) | $I_{IO}=-2mA, T_A \leq 125^\circ C$ | $V_{DD}-800$ | | |
| $V_{OL}^{1)3)}$ | Output low level voltage for PA3/RESET standard I/O pin (see Figure 55) | $I_{IO}=+2mA, T_A \leq 125^\circ C$ | | 700 | |
| | | $I_{IO}=+2mA, T_A \leq 125^\circ C$ | | 200 | |
| | Output low level voltage for a high sink I/O pin when 4 pins are sunk at same time (see Figure 58) | $I_{IO}=+8mA, T_A \leq 125^\circ C$ | | 800 | |
| $V_{OH}^{2)3)}$ | Output high level voltage for an I/O pin when 4 pins are sourced at same time (see Figure 61) | $I_{IO}=-2mA, T_A \leq 125^\circ C$ | $V_{DD}-900$ | | |

Notes:

1. The I_{IO} current sunk must always respect the absolute maximum rating specified in Section 13.2.2 and the sum of I_{IO} (I/O ports and control pins) must not exceed I_{VSS} .
2. The I_{IO} current sourced must always respect the absolute maximum rating specified in Section 13.2.2 and the sum of I_{IO} (I/O ports and control pins) must not exceed I_{VDD} . True open drain I/O pins do not have V_{OH} .
3. Not tested in production, based on characterization results.

I/O PORT PIN CHARACTERISTICS (Cont'd)

Figure 55. Typical V_{OL} at $v_{DD} = 2.4V$ (standard pins)

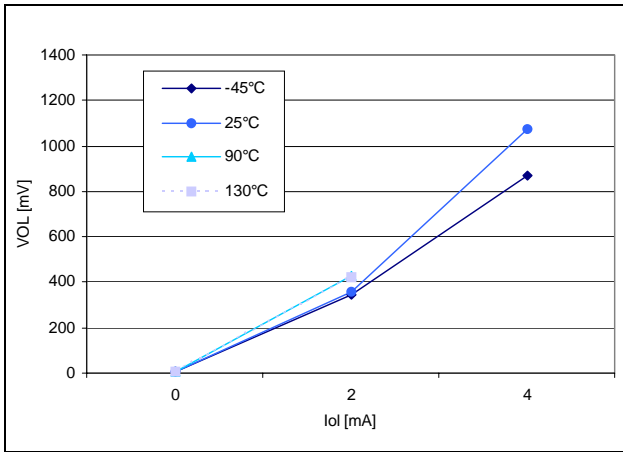

Figure 58. Typical V_{OL} at $V_{DD} = 2.4V$ (HS pins)

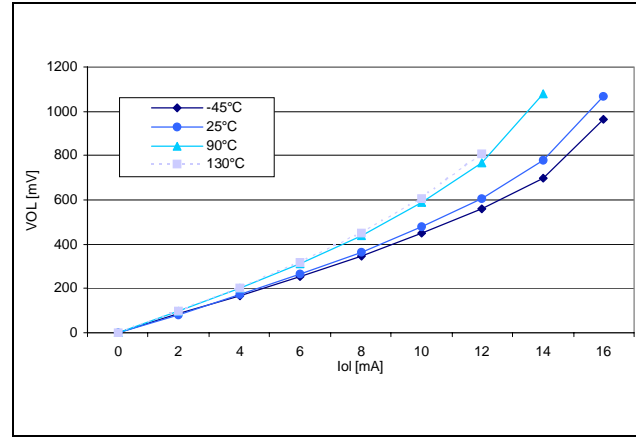

Figure 56. Typical v_{OL} at $v_{DD} = 3V$ (standard pins)

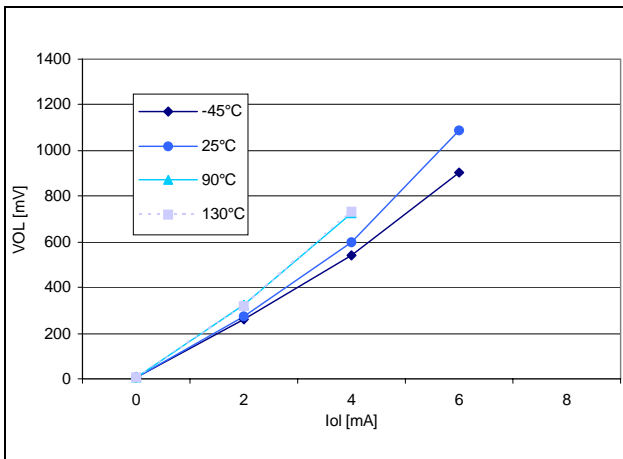

Figure 59. Typical V_{OL} at $V_{DD} = 3V$ (HS pins)

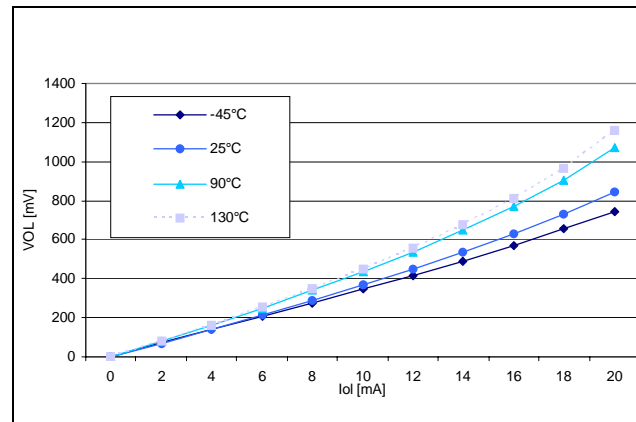

Figure 57. Typical V_{OL} at $V_{DD} = 5V$ (standard pins)

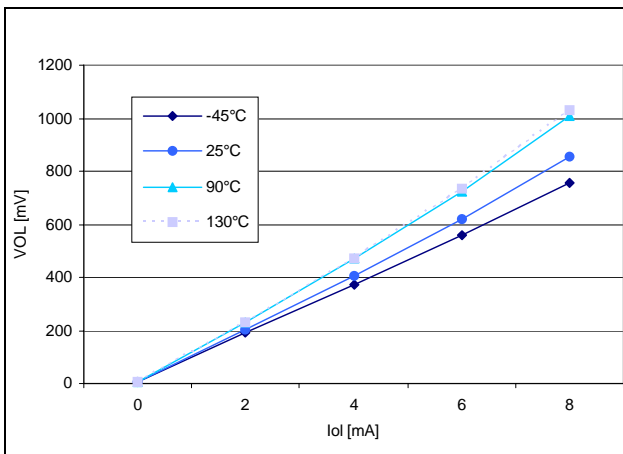
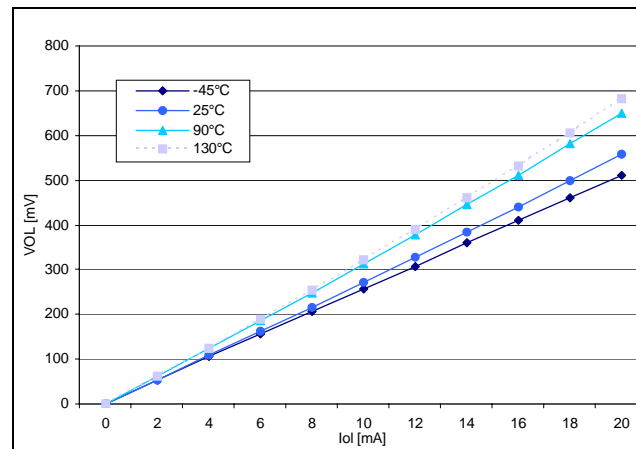

Figure 60. Typical V_{OL} at $V_{DD} = 5V$ (HS pins)



I/O PORT PIN CHARACTERISTICS (Cont'd)

Figure 61. Typical $V_{DD}-V_{OH}$ at $V_{DD} = 2.4V$ (HS pins)

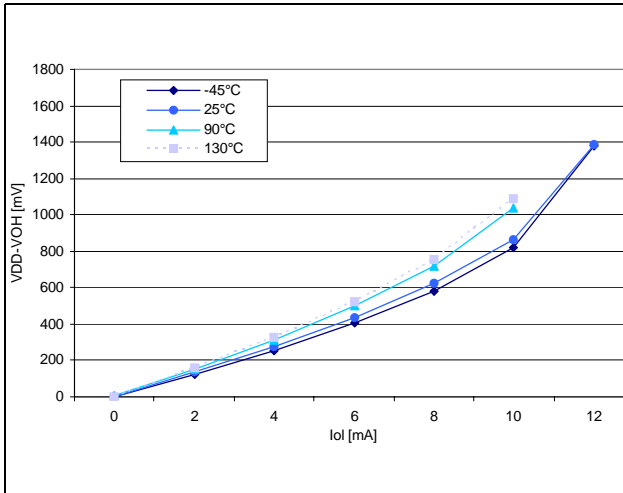

Figure 63. Typical $V_{DD}-V_{OH}$ at $V_{DD} = 5V$ (HS pins)

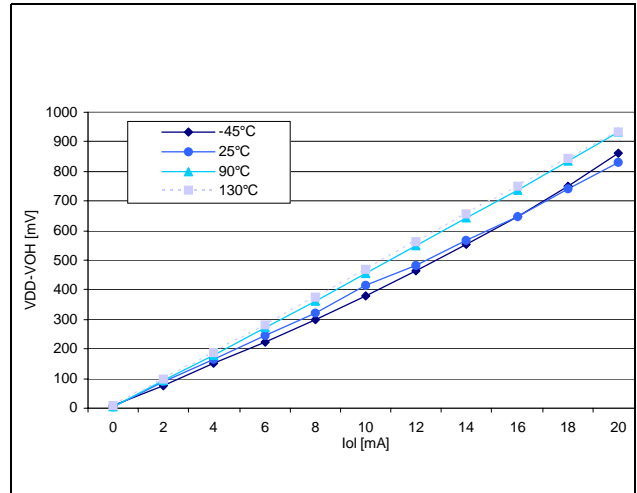
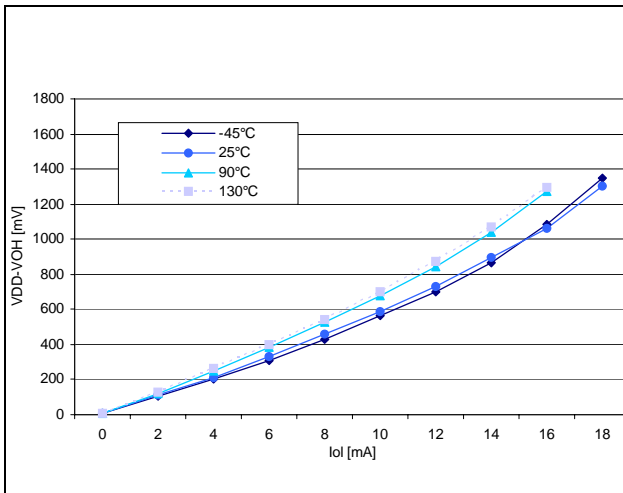

Figure 62. Typical $V_{DD}-V_{OH}$ at $V_{DD} = 3V$ (HS pins)



I/O PORT PIN CHARACTERISTICS (Cont'd)

Figure 64. Typical V_{OL} vs. V_{DD} (HS pins)

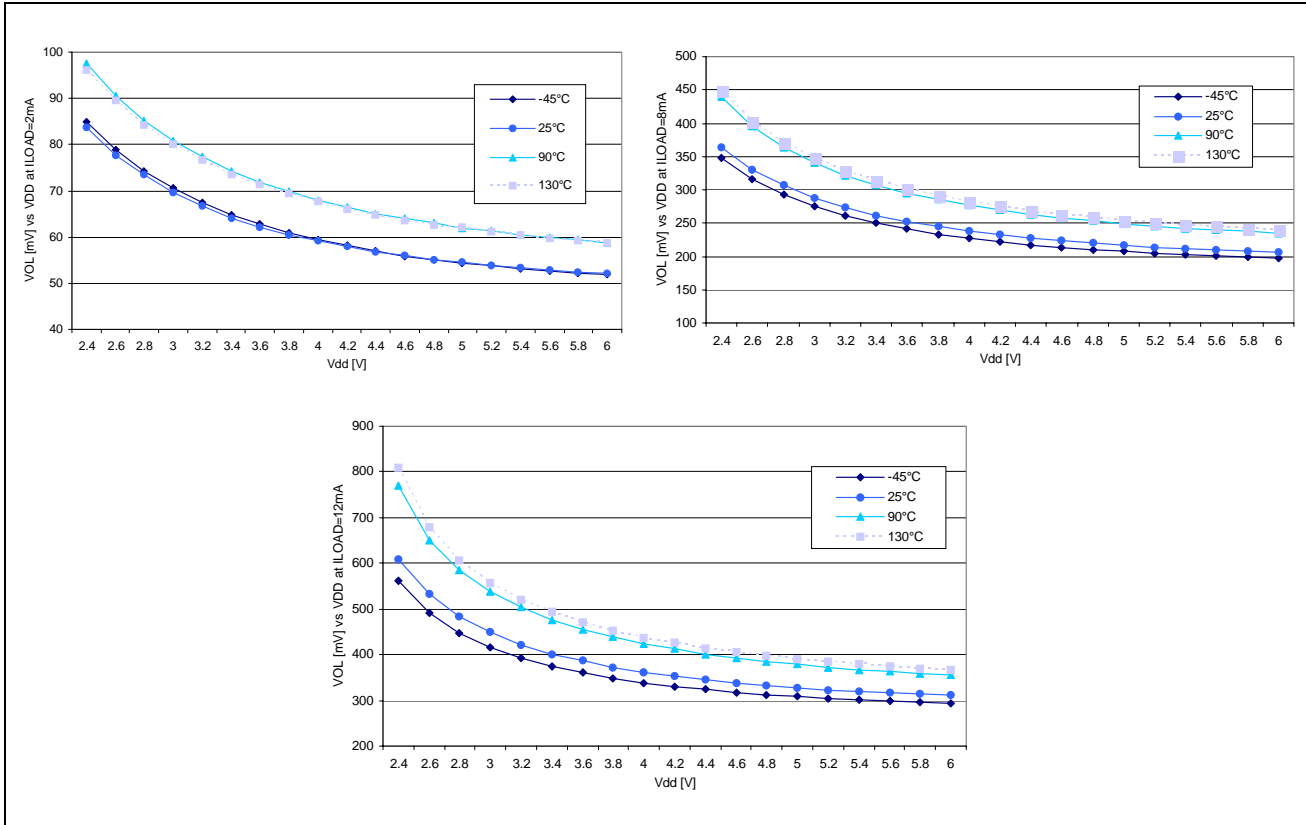
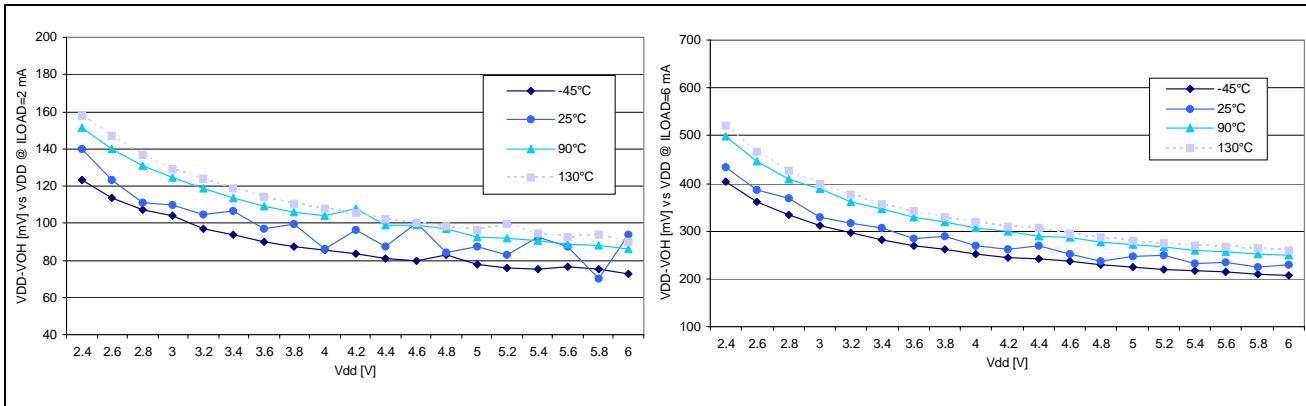

Figure 65. Typical $V_{DD}-V_{OH}$ vs. V_{DD} (HS pins)



13.9 CONTROL PIN CHARACTERISTICS

13.9.1 Asynchronous $\overline{\text{RESET}}$ Pin

$T_A = -40^\circ\text{C}$ to 125°C , unless otherwise specified

| Symbol | Parameter | Conditions | Min | Typ | Max | Unit | |
|------------------|--|-----------------------------|---------------------|------------------|---------------------|---------------|------------|
| V_{IL} | Input low level voltage | | $V_{SS} - 0.3$ | | $0.3 \times V_{DD}$ | V | |
| V_{IH} | Input high level voltage | | $0.7 \times V_{DD}$ | | $V_{DD} + 0.3$ | | |
| V_{hys} | Schmitt trigger voltage hysteresis ¹⁾ | | | 2 | | V | |
| V_{OL} | Output low level voltage ²⁾ | $V_{DD}=5V$ $I_{IO}=+2mA$ | | | 400 | mV | |
| R_{ON} | Pull-up equivalent resistor ³⁾ | $V_{IN}=V_{SS}$ | $V_{DD}=5V$ | 30 | 50 | 70 | k Ω |
| | | | $V_{DD}=3V$ | | 90 ¹⁾ | | |
| $t_{w(RSTL)out}$ | Generated reset pulse duration | Internal reset sources | | 90 ¹⁾ | | μs | |
| $t_{h(RSTL)in}$ | External reset pulse hold time ⁴⁾ | | 20 | | | μs | |
| $t_{g(RSTL)in}$ | Filtered glitch duration | | | 200 | | ns | |

Notes:

1. Data based on characterization results, not tested in production.
2. The I_{IO} current sunk must always respect the absolute maximum rating specified in [section 13.2.2 on page 75](#) and the sum of I_{IO} (I/O ports and control pins) must not exceed I_{VSS} .
3. The R_{ON} pull-up equivalent resistor is based on a resistive transistor. Specified for voltages on $\overline{\text{RESET}}$ pin between V_{ILmax} and V_{DD} .
4. To guarantee the reset of the device, a minimum pulse has to be applied to the $\overline{\text{RESET}}$ pin. All short pulses applied on $\overline{\text{RESET}}$ pin with a duration below $t_{h(RSTL)in}$ can be ignored.

CONTROL PIN CHARACTERISTICS (Cont'd)

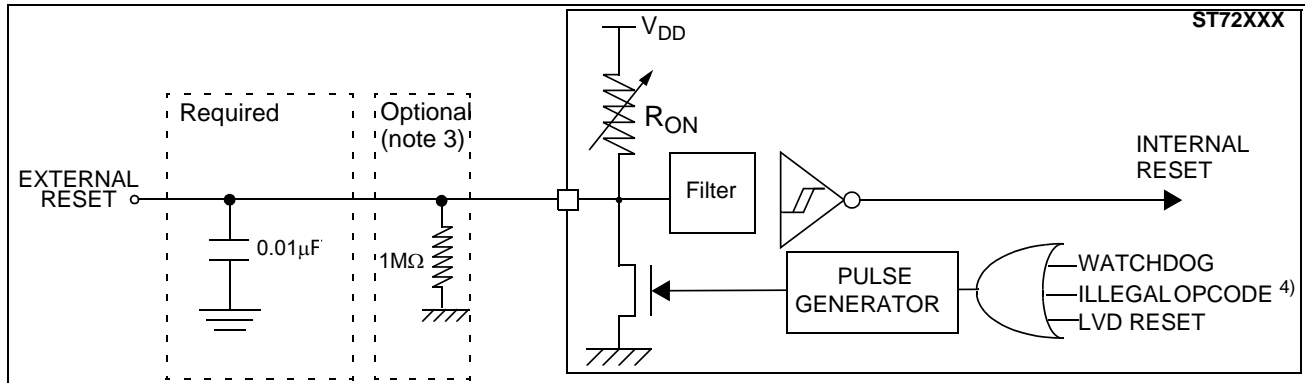
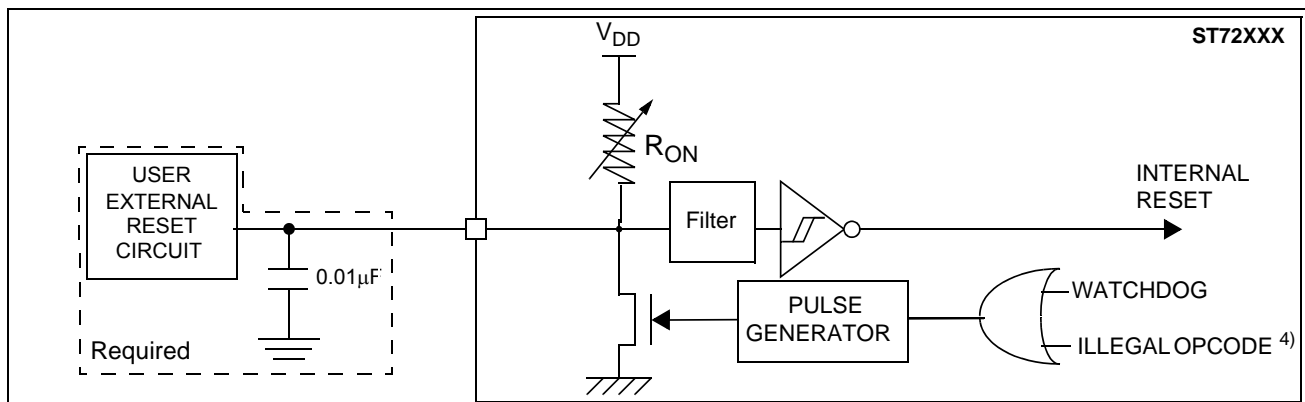
Figure 66. $\overline{\text{RESET}}$ pin protection when LVD is enabled.¹⁾²⁾³⁾Figure 67. $\overline{\text{RESET}}$ pin protection when LVD is disabled.¹⁾**Note 1:**

- The reset network protects the device against parasitic resets.
- The output of the external reset circuit must have an open-drain output to drive the ST7 reset pad. Otherwise the device can be damaged when the ST7 generates an internal reset (LVD or watchdog).
- Whatever the reset source is (internal or external), the user must ensure that the level on the $\overline{\text{RESET}}$ pin can go below the V_{IL} max. level specified in [section 13.9.1 on page 96](#). Otherwise the reset will not be taken into account internally.
- Because the reset circuit is designed to allow the internal RESET to be output in the $\overline{\text{RESET}}$ pin, the user must ensure that the current sunk on the $\overline{\text{RESET}}$ pin is less than the absolute maximum value specified for $I_{INJ}(\overline{\text{RESET}})$ in [section 13.2.2 on page 75](#).

Note 2: In case a capacitive power supply is used, it is recommended to connect a 1M Ω pull-down resistor to the $\overline{\text{RESET}}$ pin to discharge any residual voltage induced by the capacitive effect of the power supply (this will add 5 μA to the power consumption of the MCU).

Note 3: Tips when using the LVD:

- 1. Check that all recommendations related to ICCCLK and reset circuit have been applied (see caution in [Table 2 on page 7](#) and notes above)
- 2. Check that the power supply is properly decoupled (100nF + 10 μF close to the MCU). Refer to AN1709 and AN2017. If this cannot be done, it is recommended to put a 100nF + 1M Ω pull-down on the RESET pin.
- 3. The capacitors connected on the RESET pin and also the power supply are key to avoid any start-up marginality. In most cases, steps 1 and 2 above are sufficient for a robust solution. Otherwise: replace 10nF pull-down on the RESET pin with a 5 μF to 20 μF capacitor.”

Note 4: Please refer to “Illegal Opcode Reset” on page 71 for more details on illegal opcode reset conditions

13.10 10-BIT ADC CHARACTERISTICS

Subject to general operating condition for V_{DD} , f_{OSC} , and T_A unless otherwise specified.

| Symbol | Parameter | Conditions | Min | Typ ¹⁾ | Max | Unit |
|------------|---|--|-----------------|-------------------|------------|-------------|
| f_{ADC} | ADC clock frequency ²⁾ | | | | 4 | MHz |
| V_{AIN} | Conversion voltage range | | V_{SS} | | V_{DD} | V |
| R_{AIN} | External input resistor | $V_{DD} = 5V, f_{ADC}=4MHz$ | | | $8k^{3)}$ | Ω |
| | | $V_{DD} = 3.3V, f_{ADC}=4MHz$ | | | $7k^{3)}$ | |
| | | $2.7V \leq V_{DD} \leq 5.5V, f_{ADC}=2MHz$ | | | $10k^{3)}$ | |
| | | $2.4V \leq V_{DD} \leq 2.7V, f_{ADC}=1MHz$ | | | $20k^{3)}$ | |
| C_{ADC} | Internal sample and hold capacitor | | | 3 | | pF |
| t_{STAB} | Stabilization time after ADC enable | $f_{CPU}=8MHz, f_{ADC}=4MHz$ | 0 ⁴⁾ | | | μs |
| t_{ADC} | Conversion time (Sample+Hold) | | 3.5 | | | |
| | - Sample capacitor loading time - Hold conversion time | | 4 10 | | | $1/f_{ADC}$ |

Notes:

1. Unless otherwise specified, typical data are based on $T_A=25^\circ C$ and $V_{DD}-V_{SS}=5V$. They are given only as design guidelines and are not tested.
2. The maximum ADC clock frequency allowed within $V_{DD} = 2.4V$ to $2.7V$ operating range is 1MHz.
3. Any added external serial resistor will downgrade the ADC accuracy (especially for resistance greater than the maximum value). Data guaranteed by Design, not tested in production.
4. The stabilization time of the A/D converter is masked by the first t_{LOAD} . The first conversion after the enable is then always valid.

Figure 68. Typical Application with ADC

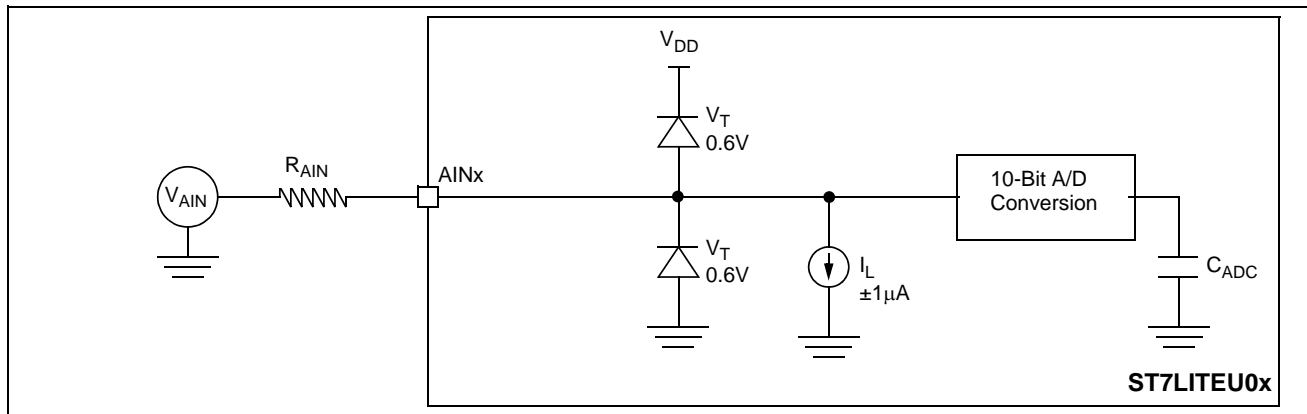

ADC CHARACTERISTICS (Cont'd)**ADC Accuracy with $V_{DD} = 3.3V$ to $5.5V$**

| Symbol ¹⁾ | Parameter | Conditions | Typ | Max | Unit |
|----------------------|------------------------------|--|-----|-----|------|
| $ E_T $ | Total unadjusted error | $f_{CPU}=8MHz, f_{ADC}=4MHz$ ¹⁾ | 2.0 | 5.0 | LSB |
| $ E_O $ | Offset error | | 0.9 | 2.5 | |
| $ E_G $ | Gain Error | | 1.0 | 1.5 | |
| $ E_D $ | Differential linearity error | | 1.2 | 3.5 | |
| $ E_L $ | Integral linearity error | | 1.1 | 4.5 | |

Note:

1. Data based on characterization results over the whole temperature range.

ADC Accuracy with $V_{DD} = 2.7V$ to $3.3V$

| Symbol ¹⁾ | Parameter | Conditions | Typ | Max | Unit |
|----------------------|------------------------------|--|-----|-----|------|
| $ E_T $ | Total unadjusted error | $f_{CPU}=4MHz, f_{ADC}=2MHz$ ¹⁾ | 1.9 | 3.0 | LSB |
| $ E_O $ | Offset error | | 0.9 | 1.5 | |
| $ E_G $ | Gain Error | | 0.8 | 1.4 | |
| $ E_D $ | Differential linearity error | | 1.4 | 2.5 | |
| $ E_L $ | Integral linearity error | | 1.1 | 2.5 | |

Note:

1. Data based on characterization results over the whole temperature range.

ADC Accuracy with $V_{DD} = 2.4V$ to $2.7V$

| Symbol ¹⁾ | Parameter | Conditions | Typ | Max | Unit |
|----------------------|------------------------------|--|-----|-----|------|
| $ E_T $ | Total unadjusted error | $f_{CPU}=2MHz, f_{ADC}=1MHz$ ¹⁾ | 2.5 | 3.5 | LSB |
| $ E_O $ | Offset error | | 1.1 | 1.5 | |
| $ E_G $ | Gain Error | | 0.5 | 1.5 | |
| $ E_D $ | Differential linearity error | | 1.1 | 2.5 | |
| $ E_L $ | Integral linearity error | | 1.2 | 2.5 | |

Note:

1. Data based on characterization results at ambient temperature and above.

ADC CHARACTERISTICS (Cont'd)

Figure 69. ADC Accuracy Characteristics

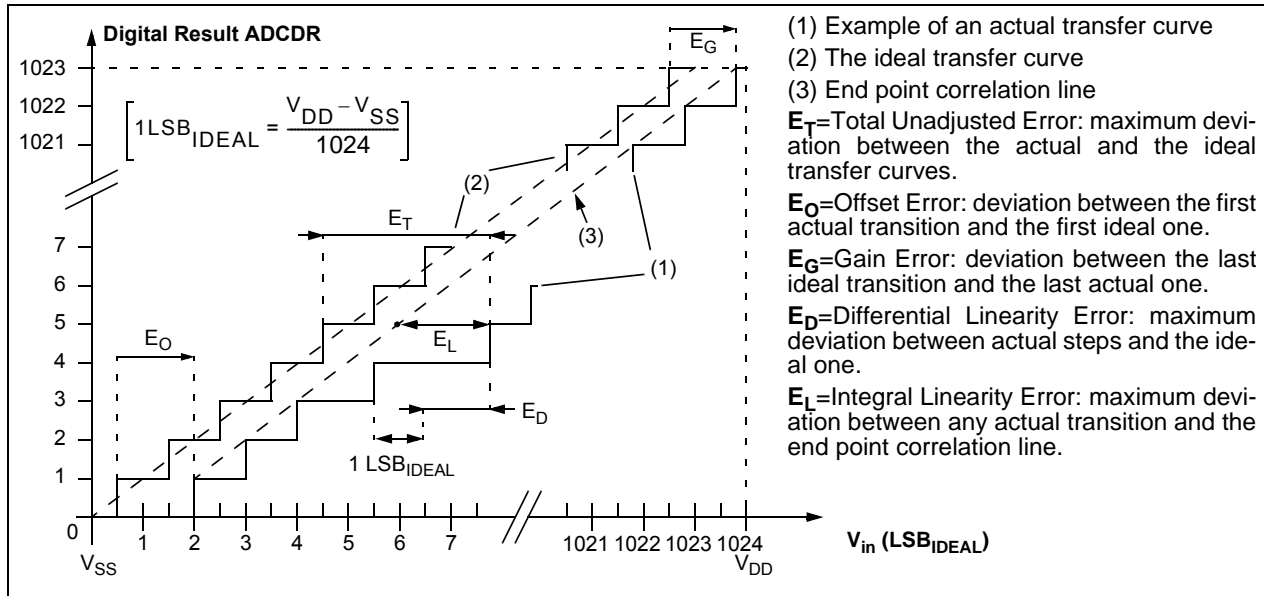

14 PACKAGE CHARACTERISTICS

In order to meet environmental requirements, ST offers these devices in ECOPACK® packages. These packages have a Lead-free second level interconnect. The category of second Level Interconnect is marked on the package and on the inner box label, in compliance with JEDEC Standard

JESD97. The maximum ratings related to soldering conditions are also marked on the inner box label.

ECOPACK is an ST trademark. ECOPACK specifications are available at: www.st.com.

14.1 PACKAGE MECHANICAL DATA

Figure 70. 8-Lead Very thin Fine pitch Dual Flat No-Lead Package

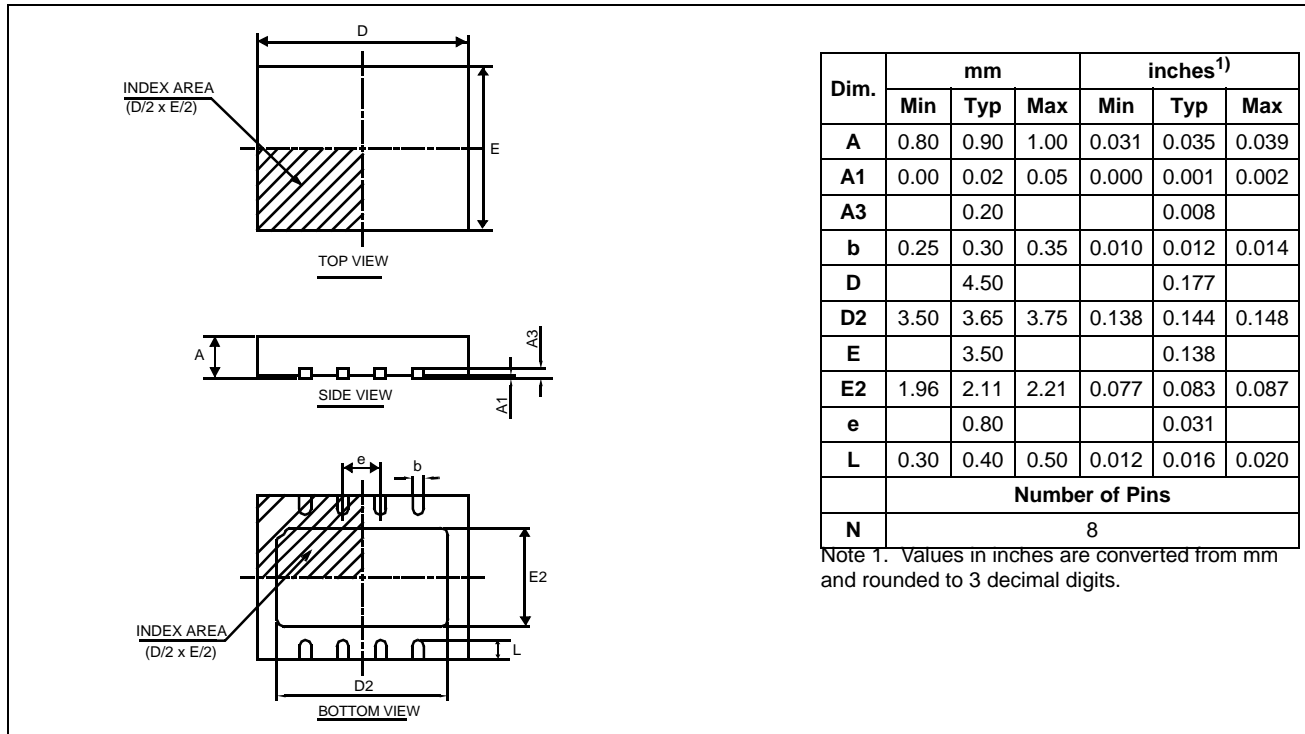

PACKAGE CHARACTERISTICS (Cont'd)

Figure 71. 8-Pin Plastic Small Outline Package, 150-mil Width

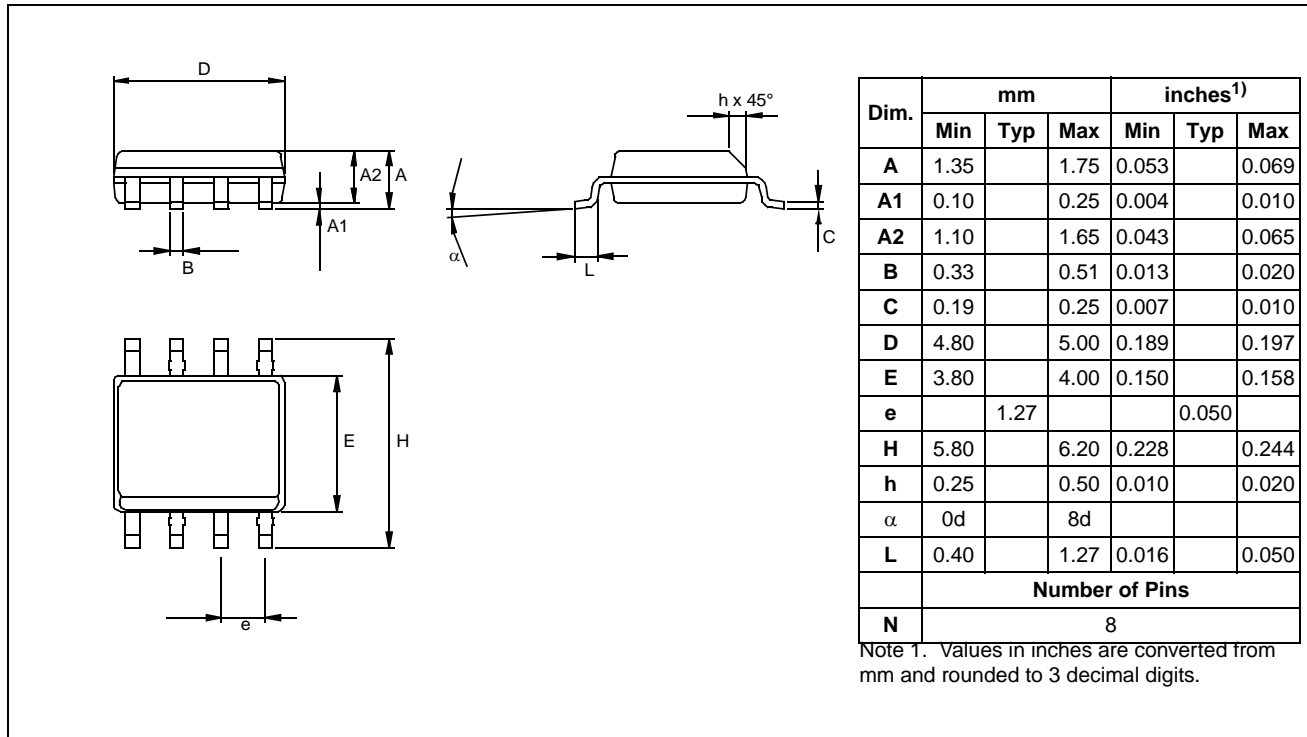
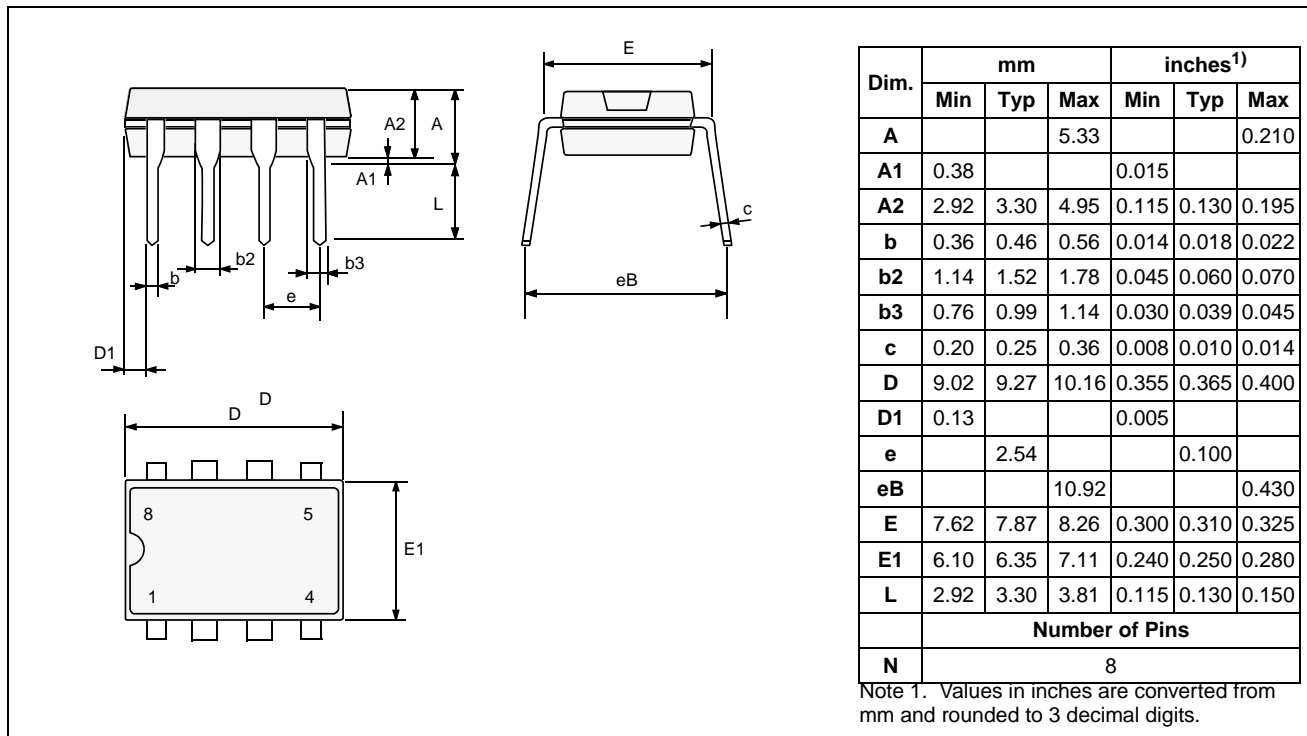

Figure 72. 8-Pin Plastic Dual In-Line Package, 300-mil Width



PACKAGE CHARACTERISTICS (Cont'd)

Figure 73. 16-Pin Plastic Dual In-Line Package, 300-mil Width

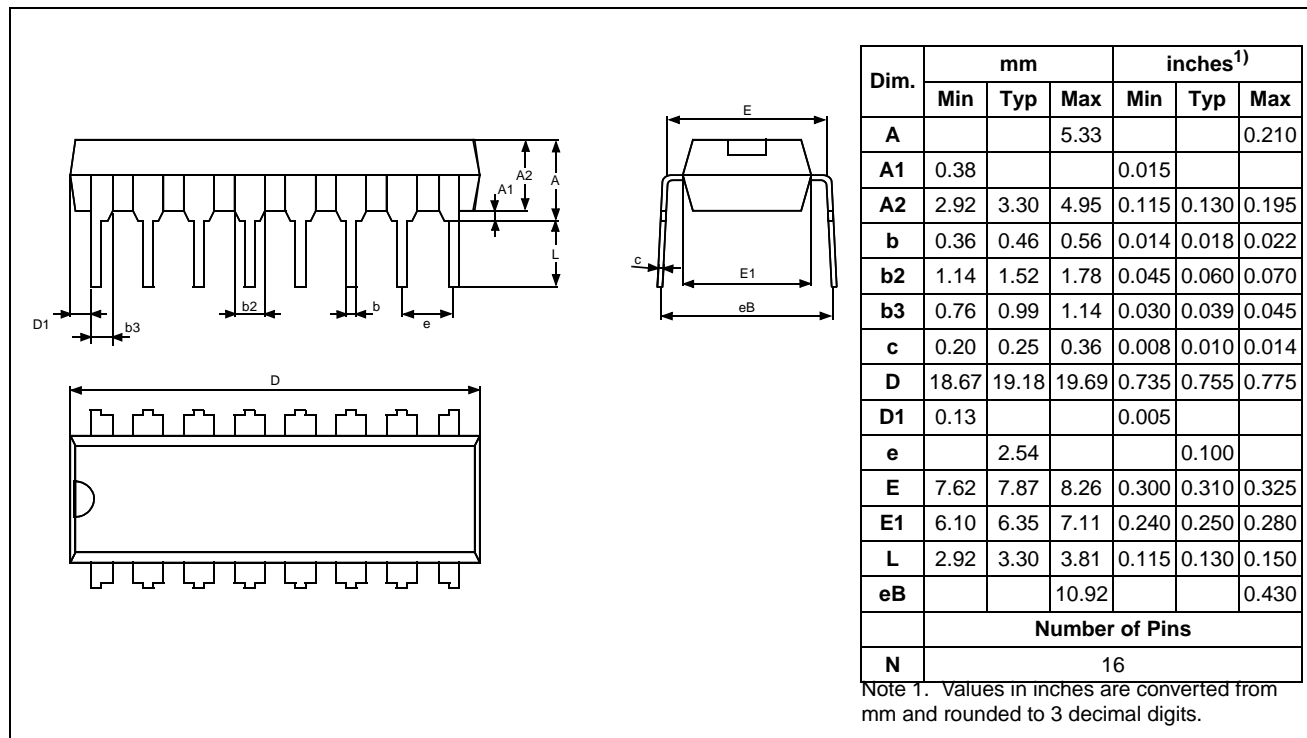

Table 24. THERMAL CHARACTERISTICS

| Symbol | Ratings | | Value | Unit |
|------------|--|-----------------------|-------|------|
| R_{thJA} | Package thermal resistance (junction to ambient) | DIP8 | 82 | °C/W |
| | | SO8 | 130 | |
| | | DFN8 (on 4-layer PCB) | 50 | |
| | | DFN8 (on 2-layer PCB) | 106 | |
| T_{Jmax} | Maximum junction temperature ¹⁾ | | 150 | °C |
| P_{Dmax} | Power dissipation ²⁾ | DIP8 | 300 | mW |
| | | SO8 | 180 | |
| | | DFN8 (on 4-layer PCB) | 500 | |
| | | DFN8 (on 2-layer PCB) | 250 | |

Notes:

1. The maximum chip-junction temperature is based on technology characteristics.

2. The maximum power dissipation is obtained from the formula $P_D = (T_J - T_A) / R_{thJA}$.

The power dissipation of an application can be defined by the user with the formula: $P_D = P_{INT} + P_{PORT}$ where P_{INT} is the chip internal power ($I_{DD} \times V_{DD}$) and P_{PORT} is the port power dissipation depending on the ports used in the application.

14.2 SOLDERING INFORMATION

In accordance with the RoHS European directive, all STMicroelectronics packages have been converted to lead-free technology, named ECOPACK™.

- ECOPACK™ packages are qualified according to the JEDEC STD-020C compliant soldering profile.
- Detailed information on the STMicroelectronics ECOPACK™ transition program is available on www.st.com/stonline/leadfree/, with specific technical Application notes covering the main technical aspects related to lead-free conversion (AN2033, AN2034, AN2035, AN2036).

Backward and forward compatibility:

The main difference between Pb and Pb-free soldering process is the temperature range.

- ECOPACK™ LQFP, SDIP, SO and DFN8 packages are fully compatible with Lead (Pb) containing soldering process (see application note AN2034)
- LQFP, SDIP and SO Pb-packages are compatible with Lead-free soldering process, nevertheless it's the customer's duty to verify that the Pb-packages maximum temperature (mentioned on the Inner box label) is compatible with their Lead-free soldering temperature.

Table 25. Soldering Compatibility (wave and reflow soldering process)

| Package | Plating material devices | Pb solder paste | Pb-free solder paste |
|-------------|--------------------------------|-----------------|----------------------|
| SDIP & PDIP | Sn (pure Tin) | Yes | Yes * |
| DFN8 | Sn (pure Tin) | Yes | Yes * |
| TQFP and SO | NiPdAu (Nickel-palladium-Gold) | Yes | Yes * |

* Assemblers must verify that the Pb-package maximum temperature (mentioned on the Inner box label) is compatible with their Lead-free soldering process.

15 DEVICE CONFIGURATION AND ORDERING INFORMATION

Each device is available for production in user programmable versions (FLASH) as well as in factory coded versions (FASTROM).

ST7PLITEU05 and ST7PLITEU09 devices are Factory Advanced Service Technique ROM (FASTROM) versions: they are factory-programmed XFlash devices.

15.1 OPTION BYTES

The two option bytes allow the hardware configuration of the microcontroller to be selected.

The option bytes can be accessed only in programming mode (for example using a standard ST7 programming tool).

OPTION BYTE 1

Bits 7:6 = **CKSEL[1:0]** *Start-up clock selection.*
This bit is used to select the startup frequency. By default, the Internal RC is selected.

| Configuration | CKSEL1 | CKSEL0 |
|------------------------------|--------|--------|
| Internal RC as Startup Clock | 0 | 0 |
| AWU RC as a Startup Clock | 0 | 1 |
| Reserved | 1 | 0 |
| External Clock on pin PA5 | 1 | 1 |

Bit 5 = Reserved, must always be 1.

Bit 4 = Reserved, must always be 0.

Bits 3:2 = **LVD[1:0]** *Low Voltage Detection selection*

These option bits enable the LVD block with a selected threshold as shown in [Table 26](#).

Table 26. LVD Threshold Configuration

| Configuration | LVD1 | LVD0 |
|---------------------------|------|------|
| LVD Off | 1 | 1 |
| Highest Voltage Threshold | 1 | 0 |
| Medium Voltage Threshold | 0 | 1 |
| Lowest Voltage Threshold | 0 | 0 |

Bit 1 = **WDG SW** *Hardware or software watchdog*

This option bit selects the watchdog type.

0: Hardware (watchdog always enabled)

1: Software (watchdog to be enabled by software)

ST7FLITEU05 and ST7FLITEU09 XFlash devices are shipped to customers with a default program memory content (FFh).

The FASTROM factory coded parts contain the code supplied by the customer. This implies that FLASH devices have to be configured by the customer using the Option Bytes while the FASTROM devices are factory-configured.

Bit 0 = **WDG HALT** *Watchdog Reset on Halt*

This option bit determines if a RESET is generated when entering HALT mode while the Watchdog is active.

0: No Reset generation when entering Halt mode

1: Reset generation when entering Halt mode

OPTION BYTE 0

Bits 7:4 = Reserved, must always be set.

Bits 3:2 = **SEC[1:0]** *Sector 0 size definition*

This option bit indicates the size of sector 0 according to the following table.

| Sector 0 Size | SEC0 | SEC1 |
|---------------|------|------|
| 0.5K | 0 | 0 |
| 1K | 0 | 1 |
| 2K | 1 | - |

Bit 1 = **FMP_R** *Read-out protection*

Readout protection, when selected provides a protection against program memory content extraction and against write access to Flash memory. Erasing the option bytes when the FMP_R option is selected will cause the whole memory to be erased first, and the device can be reprogrammed. Refer to [Section 4.5](#) and the ST7 Flash Programming Reference Manual for more details.

0: Read-out protection off

1: Read-out protection on

Bit 0 = **FMP_W** *FLASH write protection*

This option indicates if the FLASH program memory is write protected.

Warning: When this option is selected, the program memory (and the option bit itself) can never be erased or programmed again.

0: Write protection off

1: Write protection on

OPTION BYTES (Cont'd)

| | OPTION BYTE 0 | | | | | | | | OPTION BYTE 1 | | | | | | | |
|---------------|---------------|---|---|---|------|------|----------|----------|---------------|------------|----------|---|------|------|-----------|-------------|
| | 7 | | | | 0 | | | | 7 | | | | 0 | | | |
| | Reserved | | | | SEC1 | SEC0 | FMP R | FMP W | CKSEL 1 | CKSEL 0 | Reserved | | LVD1 | LVD0 | WDG SW | WDG HALT |
| Default Value | 1 | 1 | 1 | 1 | 0 | 0 | 0 | 0 | 0 | 0 | 1 | 0 | 1 | 1 | 1 | 1 |

15.2 ORDERING INFORMATION

Customer code is made up of the FASTROM contents and the list of the selected options (if any). The FASTROM contents are to be sent on diskette, or by electronic means, with the S19 hexadecimal file generated by the development tool. All unused bytes must be set to FFh. The selected options are communicated to STMicroelectronics us-

ing the correctly completed OPTION LIST appended.

Refer to application note AN1635 for information on the counter listing returned by ST after code has been transferred.

The STMicroelectronics Sales Organization will be pleased to provide detailed information on contractual points.

Table 27. Supported part numbers

| Part Number | Program Memory (Bytes) | RAM (Bytes) | Data EEPROM (Bytes) | ADC | Temp. Range | Package | Conditioning |
|-----------------|------------------------|-------------|---------------------|--------|--------------|---------------------|--------------|
| ST7FLITEU05B6 | 2K FLASH | 128 | - | 10-bit | -40°C +85°C | DIP8 | Tube |
| ST7FLITEU05M6 | | | - | 10-bit | | SO8 | Tube |
| ST7FLITEU05M6TR | | | - | 10-bit | | SO8 | Tape & Reel |
| ST7FLITEU05U6TR | | | - | 10-bit | | DFN8 | Tape & Reel |
| ST7FLITEU09B6 | 2K FLASH | 128 | 128 | 10-bit | -40°C +85°C | DIP8 | Tube |
| ST7FLITEU09M6 | | | | 10-bit | | SO8 | Tube |
| ST7FLITEU09M6TR | | | | 10-bit | | SO8 | Tape & Reel |
| ST7FLITEU09U6 | | | | 10-bit | | DFN8 | Tray |
| ST7FLITEU09U6TR | | | | 10-bit | | DFN8 | Tape & Reel |
| ST7FLITEU01CD | 2K FLASH | 128 | - | - | -40°C +125°C | DIP16 ¹⁾ | Tube |
| ST7PLITEU05B6 | 2K FASTROM | 128 | - | 10-bit | -40°C +85°C | DIP8 | Tube |
| ST7PLITEU05M6 | | | - | 10-bit | | SO8 | Tube |
| ST7PLITEU05M6TR | | | - | 10-bit | | SO8 | Tape & Reel |
| ST7PLITEU05U6TR | | | - | 10-bit | | DFN8 | Tape & Reel |
| ST7PLITEU09B6 | 2K FASTROM | 128 | 128 | 10-bit | -40°C +85°C | DIP8 | Tube |
| ST7PLITEU09M6 | | | | 10-bit | | SO8 | Tube |
| ST7PLITEU09M6TR | | | | 10-bit | | SO8 | Tape & Reel |
| ST7PLITEU09U6 | | | | 10-bit | | DFN8 | Tray |
| ST7PLITEU09U6TR | | | | 10-bit | | DFN8 | Tape & Reel |
| ST7FLITEU05B3 | 2K FLASH | 128 | - | 10-bit | -40°C +125°C | DIP8 | Tube |
| ST7FLITEU05M3 | | | - | 10-bit | | SO8 | Tube |
| ST7FLITEU05M3TR | | | - | 10-bit | | SO8 | Tape & Reel |
| ST7FLITEU05U3TR | | | - | 10-bit | | DFN8 | Tape & Reel |
| ST7FLITEU09B3 | 2K FLASH | 128 | 128 | 10-bit | -40°C +125°C | DIP8 | Tube |
| ST7FLITEU09M3 | | | | 10-bit | | SO8 | Tube |
| ST7FLITEU09M3TR | | | | 10-bit | | SO8 | Tape & Reel |
| ST7FLITEU09U3 | | | | 10-bit | | DFN8 | Tray |
| ST7FLITEU09U3TR | | | | 10-bit | | DFN8 | Tape & Reel |

ST7LITEU05 ST7LITEU09

| | | | | | | | |
|-----------------|------------|-----|-----|--------|--------------|------|-------------|
| ST7PLITEU05B3 | 2K FASTROM | 128 | - | 10-bit | -40°C +125°C | DIP8 | Tube |
| ST7PLITEU05M3 | | | - | 10-bit | | SO8 | Tube |
| ST7PLITEU05M3TR | | | - | 10-bit | | | Tape & Reel |
| ST7PLITEU05U3TR | | | - | 10-bit | | DFN8 | Tape & Reel |
| ST7PLITEU09B3 | 2K FASTROM | 128 | 128 | 10-bit | -40°C +125°C | DIP8 | Tube |
| ST7PLITEU09M3 | | | | 10-bit | | SO8 | Tube |
| ST7PLITEU09M3TR | | | | 10-bit | | | Tape & Reel |
| ST7PLITEU09U3 | | | | 10-bit | | DFN8 | Tray |
| ST7PLITEU09U3TR | | | | 10-bit | | | Tape & Reel |

Contact ST sales office for product availability

Note:

1. DIP16 for development or tool prototyping purposes only, not orderable in production quantities.

ST7LITEU0 FASTROM MICROCONTROLLER OPTION LIST

(Last update: April 2007)

Customer
AddressContact
Phone No

Reference FASTROM Code*:

*FASTROM code name is assigned by STMicroelectronics.

FASTROM code must be sent in .S19 format. .Hex extension cannot be processed.

Device Type/Memory Size/Package (check only one option):

| FASTROM DEVICE: | | 2K FASTROM |
|-----------------|--|--------------------------|
| PDIP8: | | <input type="checkbox"/> |
| SO8: | | <input type="checkbox"/> |
| DFN8: | | <input type="checkbox"/> |

Conditioning (check only one option):

DIP package: Tube
SO package: Tape & Reel Tube
DFN package: Tape & Reel Tray (ST7LITEU09 only)

Special Marking: No Yes "_____"

Authorized characters are letters, digits, '.', '-', '/' and spaces only.

Maximum character count:

PDIP8/SO8/DFN8 (8 char. max) : _____

Temperature range: -40°C to +85°C -40°C to +125°C

Clock Source Selection: External Clock
 AWU RC Oscillator
 Internal RC Oscillator

Sector 0 size: 0.5K 1K 2KReadout Protection: Disabled EnabledFLASH Write Protection Disabled Enabled

LVD Reset Disabled Highest threshold
 Medium threshold
 Lowest threshold

Watchdog Selection: Software Activation Hardware ActivationWatchdog Reset on Halt: Disabled Enabled

Comments :

Supply Operating Range in the application:

Notes

Date:

Signature:

Important note: Not all configurations are available. See [section 15.1 on page 105](#) for authorized option byte combinations.

Please download the latest version of this option list from:
<http://www.st.com/mcu> > downloads > ST7 microcontrollers > Option list

15.3 DEVELOPMENT TOOLS

Development tools for the ST7 microcontrollers include a complete range of hardware systems and software tools from STMicroelectronics and third-party tool suppliers. The range of tools includes solutions to help you evaluate microcontroller peripherals, develop and debug your application, and program your microcontrollers.

15.3.1 Starter kits

ST offers complete, affordable **starter kits**. Starter kits are complete hardware/software tool packages that include features and samples to help you quickly start developing your application.

15.3.2 Development and debugging tools

Application development for ST7 is supported by fully optimizing **C Compilers** and the **ST7 Assembler-Linker** toolchain, which are all seamlessly integrated in the ST7 integrated development environments in order to facilitate the debugging and fine-tuning of your application. The Cosmic C Compiler is available in a free version that outputs up to 16KBytes of code.

The range of hardware tools includes full-featured **ST7-EMU3 series emulators** and the low-cost **RLink** in-circuit debugger/programmer. These tools are supported by the **ST7 Toolset** from STMicroelectronics, which includes the STVD7 integrated development environment (IDE) with

high-level language debugger, editor, project manager and integrated programming interface.

15.3.3 Programming tools

During the development cycle, the **ST7-EMU3 series emulators** and the **RLink** provide in-circuit programming capability for programming the Flash microcontroller on your application board.

ST also provides a low-cost dedicated in-circuit programmer, the **ST7-STICK**, as well as **ST7 Socket Boards** which provide all the sockets required for programming any of the devices in a specific ST7 sub-family on a platform that can be used with any tool with in-circuit programming capability for ST7.

For production programming of ST7 devices, ST's third-party tool partners also provide a complete range of gang and automated programming solutions, which are ready to integrate into your production environment.

15.3.4 Order Codes for Development and Programming Tools

Table 28 below lists the ordering codes for the ST7LITEU0x development and programming tools. For additional ordering codes for spare parts and accessories, refer to the online product selector at www.st.com/mcu.

Table 28. Development tool order codes for the ST7LITEU0x family

| Supported Products | In-circuit Debugger, RLink Series ¹⁾ | | Emulator | Programming tool | |
|----------------------------|---|--------------------------------|-----------------------------|--|---------------------------|
| | Starter Kit without Demo Board | Starter Kit with Demo Board | | In-circuit Programmer | ST Socket Boards and EPBs |
| ST7FLITEU05 ST7FLITEU09 | STX-RLINK ²⁾ | ST7FLITE-SK/RAIS ²⁾ | ST7MDT10-EMU3 ⁴⁾ | STX-RLINK ST7-STICK ³⁾⁵⁾ | ST7SB10-SU0 ³⁾ |

Notes:

1. Available from ST or from Raisonance, www.raisonance.com
2. USB connection to PC
3. Add suffix /EU, /UK or /US for the power supply for your region
4. Includes connection kit for DIP16/SO16 only. See "How to order an EMU or DVP" in ST product and tool selection guide for connection kit ordering information
5. Parallel port connection to PC

15.4 ST7 APPLICATION NOTES

Table 29. ST7 Application Notes

| IDENTIFICATION | DESCRIPTION |
|-----------------------------|--|
| APPLICATION EXAMPLES | |
| AN1658 | SERIAL NUMBERING IMPLEMENTATION |
| AN1720 | MANAGING THE READ-OUT PROTECTION IN FLASH MICROCONTROLLERS |
| AN1755 | A HIGH RESOLUTION/PRECISION THERMOMETER USING ST7 AND NE555 |
| AN1756 | CHOOSING A DALI IMPLEMENTATION STRATEGY WITH ST7DALI |
| AN1812 | A HIGH PRECISION, LOW COST, SINGLE SUPPLY ADC FOR POSITIVE AND NEGATIVE INPUT VOLTAGES |
| EXAMPLE DRIVERS | |
| AN 969 | SCI COMMUNICATION BETWEEN ST7 AND PC |
| AN 970 | SPI COMMUNICATION BETWEEN ST7 AND EEPROM |
| AN 971 | I ² C COMMUNICATION BETWEEN ST7 AND M24CXX EEPROM |
| AN 972 | ST7 SOFTWARE SPI MASTER COMMUNICATION |
| AN 973 | SCI SOFTWARE COMMUNICATION WITH A PC USING ST72251 16-BIT TIMER |
| AN 974 | REAL TIME CLOCK WITH ST7 TIMER OUTPUT COMPARE |
| AN 976 | DRIVING A BUZZER THROUGH ST7 TIMER PWM FUNCTION |
| AN 979 | DRIVING AN ANALOG KEYBOARD WITH THE ST7 ADC |
| AN 980 | ST7 KEYPAD DECODING TECHNIQUES, IMPLEMENTING WAKE-UP ON KEYSTROKE |
| AN1017 | USING THE ST7 UNIVERSAL SERIAL BUS MICROCONTROLLER |
| AN1041 | USING ST7 PWM SIGNAL TO GENERATE ANALOG OUTPUT (SINUSOID) |
| AN1042 | ST7 ROUTINE FOR I ² C SLAVE MODE MANAGEMENT |
| AN1044 | MULTIPLE INTERRUPT SOURCES MANAGEMENT FOR ST7 MCUS |
| AN1045 | ST7 S/W IMPLEMENTATION OF I ² C BUS MASTER |
| AN1046 | UART EMULATION SOFTWARE |
| AN1047 | MANAGING RECEPTION ERRORS WITH THE ST7 SCI PERIPHERALS |
| AN1048 | ST7 SOFTWARE LCD DRIVER |
| AN1078 | PWM DUTY CYCLE SWITCH IMPLEMENTING TRUE 0% & 100% DUTY CYCLE |
| AN1082 | DESCRIPTION OF THE ST72141 MOTOR CONTROL PERIPHERALS REGISTERS |
| AN1083 | ST72141 BLDC MOTOR CONTROL SOFTWARE AND FLOWCHART EXAMPLE |
| AN1105 | ST7 PCAN PERIPHERAL DRIVER |
| AN1129 | PWM MANAGEMENT FOR BLDC MOTOR DRIVES USING THE ST72141 |
| AN1130 | AN INTRODUCTION TO SENSORLESS BRUSHLESS DC MOTOR DRIVE APPLICATIONS WITH THE ST72141 |
| AN1148 | USING THE ST7263 FOR DESIGNING A USB MOUSE |
| AN1149 | HANDLING SUSPEND MODE ON A USB MOUSE |
| AN1180 | USING THE ST7263 KIT TO IMPLEMENT A USB GAME PAD |
| AN1276 | BLDC MOTOR START ROUTINE FOR THE ST72141 MICROCONTROLLER |
| AN1321 | USING THE ST72141 MOTOR CONTROL MCU IN SENSOR MODE |
| AN1325 | USING THE ST7 USB LOW-SPEED FIRMWARE V4.X |
| AN1445 | EMULATED 16-BIT SLAVE SPI |
| AN1475 | DEVELOPING AN ST7265X MASS STORAGE APPLICATION |
| AN1504 | STARTING A PWM SIGNAL DIRECTLY AT HIGH LEVEL USING THE ST7 16-BIT TIMER |
| AN1602 | 16-BIT TIMING OPERATIONS USING ST7262 OR ST7263B ST7 USB MCUS |
| AN1633 | DEVICE FIRMWARE UPGRADE (DFU) IMPLEMENTATION IN ST7 NON-USB APPLICATIONS |
| AN1712 | GENERATING A HIGH RESOLUTION SINEWAVE USING ST7 PWMART |
| AN1713 | SMBUS SLAVE DRIVER FOR ST7 I ² C PERIPHERALS |
| AN1753 | SOFTWARE UART USING 12-BIT ART |

Table 29. ST7 Application Notes

| IDENTIFICATION | DESCRIPTION |
|------------------------------|---|
| AN1947 | ST7MC PMAC SINE WAVE MOTOR CONTROL SOFTWARE LIBRARY |
| GENERAL PURPOSE | |
| AN1476 | LOW COST POWER SUPPLY FOR HOME APPLIANCES |
| AN1526 | ST7FLITE0 QUICK REFERENCE NOTE |
| AN1709 | EMC DESIGN FOR ST MICROCONTROLLERS |
| AN1752 | ST72324 QUICK REFERENCE NOTE |
| PRODUCT EVALUATION | |
| AN 910 | PERFORMANCE BENCHMARKING |
| AN 990 | ST7 BENEFITS VS INDUSTRY STANDARD |
| AN1077 | OVERVIEW OF ENHANCED CAN CONTROLLERS FOR ST7 AND ST9 MCUS |
| AN1086 | U435 CAN-DO SOLUTIONS FOR CAR MULTIPLEXING |
| AN1103 | IMPROVED B-EMF DETECTION FOR LOW SPEED, LOW VOLTAGE WITH ST72141 |
| AN1150 | BENCHMARK ST72 VS PC16 |
| AN1151 | PERFORMANCE COMPARISON BETWEEN ST72254 & PC16F876 |
| AN1278 | LIN (LOCAL INTERCONNECT NETWORK) SOLUTIONS |
| PRODUCT MIGRATION | |
| AN1131 | MIGRATING APPLICATIONS FROM ST72511/311/214/124 TO ST72521/321/324 |
| AN1322 | MIGRATING AN APPLICATION FROM ST7263 REV.B TO ST7263B |
| AN1365 | GUIDELINES FOR MIGRATING ST72C254 APPLICATIONS TO ST72F264 |
| AN1604 | HOW TO USE ST7MDT1-TRAIN WITH ST72F264 |
| AN2200 | GUIDELINES FOR MIGRATING ST7LITE1X APPLICATIONS TO ST7FLITE1XB |
| PRODUCT OPTIMIZATION | |
| AN 982 | USING ST7 WITH CERAMIC RESONATOR |
| AN1014 | HOW TO MINIMIZE THE ST7 POWER CONSUMPTION |
| AN1015 | SOFTWARE TECHNIQUES FOR IMPROVING MICROCONTROLLER EMC PERFORMANCE |
| AN1040 | MONITORING THE VBUS SIGNAL FOR USB SELF-POWERED DEVICES |
| AN1070 | ST7 CHECKSUM SELF-CHECKING CAPABILITY |
| AN1181 | ELECTROSTATIC DISCHARGE SENSITIVE MEASUREMENT |
| AN1324 | CALIBRATING THE RC OSCILLATOR OF THE ST7FLITE0 MCU USING THE MAINS |
| AN1502 | EMULATED DATA EEPROM WITH ST7 HDFLASH MEMORY |
| AN1529 | EXTENDING THE CURRENT & VOLTAGE CAPABILITY ON THE ST7265 VDDF SUPPLY |
| AN1530 | ACCURATE TIMEBASE FOR LOW-COST ST7 APPLICATIONS WITH INTERNAL RC OSCILLATOR |
| AN1605 | USING AN ACTIVE RC TO WAKEUP THE ST7LITE0 FROM POWER SAVING MODE |
| AN1636 | UNDERSTANDING AND MINIMIZING ADC CONVERSION ERRORS |
| AN1828 | PIR (PASSIVE INFRARED) DETECTOR USING THE ST7FLITE05/09/SUPERLITE |
| AN1946 | SENSORLESS BLDC MOTOR CONTROL AND BEMF SAMPLING METHODS WITH ST7MC |
| AN1953 | PFC FOR ST7MC STARTER KIT |
| AN1971 | ST7LITE0 MICROCONTROLLED BALLAST |
| PROGRAMMING AND TOOLS | |
| AN 978 | ST7 VISUAL DEVELOP SOFTWARE KEY DEBUGGING FEATURES |
| AN 983 | KEY FEATURES OF THE COSMIC ST7 C-COMPILER PACKAGE |
| AN 985 | EXECUTING CODE IN ST7 RAM |
| AN 986 | USING THE INDIRECT ADDRESSING MODE WITH ST7 |
| AN 987 | ST7 SERIAL TEST CONTROLLER PROGRAMMING |
| AN 988 | STARTING WITH ST7 ASSEMBLY TOOL CHAIN |
| AN1039 | ST7 MATH UTILITY ROUTINES |

Table 29. ST7 Application Notes

| IDENTIFICATION | DESCRIPTION |
|----------------------------|---|
| AN1071 | HALF DUPLEX USB-TO-SERIAL BRIDGE USING THE ST72611 USB MICROCONTROLLER |
| AN1106 | TRANSLATING ASSEMBLY CODE FROM HC05 TO ST7 |
| AN1179 | PROGRAMMING ST7 FLASH MICROCONTROLLERS IN REMOTE ISP MODE (IN-SITU PROGRAMMING) |
| AN1446 | USING THE ST72521 EMULATOR TO DEBUG AN ST72324 TARGET APPLICATION |
| AN1477 | EMULATED DATA EEPROM WITH XFLASH MEMORY |
| AN1527 | DEVELOPING A USB SMARTCARD READER WITH ST7SCR |
| AN1575 | ON-BOARD PROGRAMMING METHODS FOR XFLASH AND HDFLASH ST7 MCUS |
| AN1576 | IN-APPLICATION PROGRAMMING (IAP) DRIVERS FOR ST7 HDFLASH OR XFLASH MCUS |
| AN1577 | DEVICE FIRMWARE UPGRADE (DFU) IMPLEMENTATION FOR ST7 USB APPLICATIONS |
| AN1601 | SOFTWARE IMPLEMENTATION FOR ST7DALI-EVAL |
| AN1603 | USING THE ST7 USB DEVICE FIRMWARE UPGRADE DEVELOPMENT KIT (DFU-DK) |
| AN1635 | ST7 CUSTOMER ROM CODE RELEASE INFORMATION |
| AN1754 | DATA LOGGING PROGRAM FOR TESTING ST7 APPLICATIONS VIA ICC |
| AN1796 | FIELD UPDATES FOR FLASH BASED ST7 APPLICATIONS USING A PC COMM PORT |
| AN1900 | HARDWARE IMPLEMENTATION FOR ST7DALI-EVAL |
| AN1904 | ST7MC THREE-PHASE AC INDUCTION MOTOR CONTROL SOFTWARE LIBRARY |
| AN1905 | ST7MC THREE-PHASE BLDC MOTOR CONTROL SOFTWARE LIBRARY |
| SYSTEM OPTIMIZATION | |
| AN1711 | SOFTWARE TECHNIQUES FOR COMPENSATING ST7 ADC ERRORS |
| AN1827 | IMPLEMENTATION OF SIGMA-DELTA ADC WITH ST7FLITE05/09 |
| AN2009 | PWM MANAGEMENT FOR 3-PHASE BLDC MOTOR DRIVES USING THE ST7FMC |
| AN2030 | BACK EMF DETECTION DURING PWM ON TIME BY ST7MC |

16 REVISION HISTORY

| Date | Revision | Main changes |
|-----------|----------|---|
| 19-Jan-07 | 0.1 | Initial release |
| 03-May-07 | 1 | <p>Added note 1 to Table 2 on page 7</p> <p>Modified section 11.3.3.4 on page 65 and added section 11.3.3.5 on page 65</p> <p>Updated section 13.3.2 on page 77, section 13.3.3 on page 77, section 13.8.1 on page 90, and section 13.3.2 on page 77</p> <p>Modified EOC bit description in section 11.3.6 on page 66</p> <p>Updated section 13.3.5.1 on page 79 and section 13.3.5.2 on page 79</p> <p>Supply current curved updated in section 13.4 on page 81</p> <p>Updated section 13.4.1 on page 81</p> <p>Added one R_{AIN} value and modified note 3 in section 13.10 on page 98</p> <p>Removed references to ST7LITEU02 part numbers</p> <p>Modified reset configuration for pin n°6 in Table 2 on page 7</p> <p>Modified Figure 14 on page 26 (added AVDTHCR)</p> <p>Added section 13.6.3 on page 86</p> <p>Modified Table 28 on page 110: added note 4 for ST7MDT10-EMU3, removed references to DVP3 and modified starter kit part number.</p> <p>Modified section 13.6.2 on page 86 (N_{RW})</p> <p>Modified section 13.7.3.1 on page 88</p> <p>Modified temperature conditions for LU in section 13.7.3.2 on page 89</p> <p>ADC accuracy maximum values inserted into tables in section 13.10 on page 98</p> <p>IPU and RPU graphs updated, Figure 53 and Figure 54 on page 91</p> <p>Supply characteristics graphs updated, Figure 13.4 on page 81</p> <p>RC oscillator consumption data table inserted, section 13.4.2 on page 82</p> <p>Internal RC oscillator data tables updated, Section 13.3.5.1, section 13.3.5.1 on page 79</p> <p>Consumption values for HALT mode inserted, section 13.4 on page 81</p> |

Please Read Carefully:

Information in this document is provided solely in connection with ST products. STMicroelectronics NV and its subsidiaries ("ST") reserve the right to make changes, corrections, modifications or improvements, to this document, and the products and services described herein at any time, without notice.

All ST products are sold pursuant to ST's terms and conditions of sale.

Purchasers are solely responsible for the choice, selection and use of the ST products and services described herein, and ST assumes no liability whatsoever relating to the choice, selection or use of the ST products and services described herein.

No license, express or implied, by estoppel or otherwise, to any intellectual property rights is granted under this document. If any part of this document refers to any third party products or services it shall not be deemed a license grant by ST for the use of such third party products or services, or any intellectual property contained therein or considered as a warranty covering the use in any manner whatsoever of such third party products or services or any intellectual property contained therein.

UNLESS OTHERWISE SET FORTH IN ST'S TERMS AND CONDITIONS OF SALE ST DISCLAIMS ANY EXPRESS OR IMPLIED WARRANTY WITH RESPECT TO THE USE AND/OR SALE OF ST PRODUCTS INCLUDING WITHOUT LIMITATION IMPLIED WARRANTIES OF MERCHANTABILITY, FITNESS FOR A PARTICULAR PURPOSE (AND THEIR EQUIVALENTS UNDER THE LAWS OF ANY JURISDICTION), OR INFRINGEMENT OF ANY PATENT, COPYRIGHT OR OTHER INTELLECTUAL PROPERTY RIGHT.

UNLESS EXPRESSLY APPROVED IN WRITING BY AN AUTHORIZED ST REPRESENTATIVE, ST PRODUCTS ARE NOT RECOMMENDED, AUTHORIZED OR WARRANTED FOR USE IN MILITARY, AIR CRAFT, SPACE, LIFE SAVING, OR LIFE SUSTAINING APPLICATIONS, NOR IN PRODUCTS OR SYSTEMS WHERE FAILURE OR MALFUNCTION MAY RESULT IN PERSONAL INJURY, DEATH, OR SEVERE PROPERTY OR ENVIRONMENTAL DAMAGE. ST PRODUCTS WHICH ARE NOT SPECIFIED AS "AUTOMOTIVE GRADE" MAY ONLY BE USED IN AUTOMOTIVE APPLICATIONS AT USER'S OWN RISK.

Resale of ST products with provisions different from the statements and/or technical features set forth in this document shall immediately void any warranty granted by ST for the ST product or service described herein and shall not create or extend in any manner whatsoever, any liability of ST.

ST and the ST logo are trademarks or registered trademarks of ST in various countries.

Information in this document supersedes and replaces all information previously supplied.

The ST logo is a registered trademark of STMicroelectronics. All other names are the property of their respective owners.

© 2007 STMicroelectronics - All rights reserved

STMicroelectronics group of companies

Australia - Belgium - Brazil - Canada - China - Czech Republic - Finland - France - Germany - Hong Kong - India - Israel - Italy - Japan - Malaysia - Malta - Morocco - Singapore - Spain - Sweden - Switzerland - United Kingdom - United States of America

www.st.com