

DATA SHEET

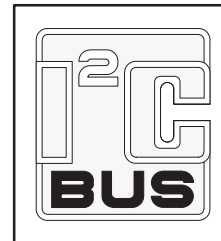

P83C660X2, P87C660X2

P83C661X2, P87C661X2

80C51 8-bit microcontroller family

16KB OTP/ROM, 512B RAM low voltage (2.7 to 5.5 V),
low power, high speed (30/33 MHz), two 400KB I²C
interfaces

Product data

Supersedes data of 2003 Jun 19

2003 Oct 02

**80C51 8-bit microcontroller family 16 KB OTP/ROM,
512B RAM, low voltage (2.7 to 5.5 V), low power, high speed
(30/33 MHz), two 400KB I²C interfaces**

P8xC660X2/661X2



DESCRIPTION

The devices are Single-Chip 8-Bit Microcontrollers manufactured in an advanced CMOS process and are derivatives of the 80C51 microcontroller family. The instruction set is 100% compatible with the 80C51 instruction set.

The devices support 6-clock/12-clock mode selection by programming an OTP bit (OX2) using parallel programming. In addition, an SFR bit (X2) in the clock control register (CKCON) also selects between 6-clock/12-clock mode.

These devices have either one or two I²C interfaces, capable of handling speeds up to 400 kbits/s (Fast I²C). They also have four 8-bit I/O ports, three 16-bit timer/event counters, a multi-source, four-priority-level, nested interrupt structure, an enhanced UART and on-chip oscillator and timing circuits.

The added features of the P8xC66xX2 make it a powerful microcontroller for applications that require pulse width modulation, high-speed I/O, I²C communication, and up/down counting capabilities such as motor control.

FEATURES

- 80C51 Central Processing Unit
 - 16 kbytes OTP (87C660X2, 87C661X2)
 - 16 kbytes ROM (83C660X2, 83C661X2)
 - 512 byte RAM
 - Boolean processor
 - Fully static operation
 - Low voltage (2.7 V to 5.5 V at 16 MHz) operation
- 12-clock operation with selectable 6-clock operation (via software or via parallel programmer)
- Memory addressing capability
 - Up to 64 kbytes ROM and 64 kbytes RAM
- Power control modes:
 - Clock can be stopped and resumed
 - Idle mode
 - Power-down mode
- CMOS and TTL compatible
- Two speed ranges at V_{CC} = 5 V
 - 0 to 30 MHz with 6-clock operation
 - 0 to 33 MHz with 12-clock operation
- Parallel programming with 87C51 compatible hardware interface to programmer
- RAM expandable externally to 64 kbytes
- Programmable Counter Array (PCA)
 - PWM
 - Capture/compare
- PLCC and LQFP packages
- Extended temperature ranges
- Dual Data Pointers
- Security bits (3 bits)
- Encryption array - 64 bytes
- 8/9 interrupt sources
- Four interrupt priority levels
- Four 8-bit I/O ports
- One I²C serial port interface has a selectable data transfer mode, either 400 kB/sec Fast-mode or 100 kB/sec Standard-mode (8xC660X2 and 8xC661X2)
- A second I²C serial port interface has the 400 kB/sec Fast data-transfer mode only and selectable slew rate control of the output pins (8xC661X2)
- Full-duplex enhanced UART
 - Framing error detection
 - Automatic address recognition
- Three 16-bit timers/counters T0, T1 (standard 80C51) and additional T2 (capture and compare)
- Programmable clock-out pin
- Asynchronous port reset
- Low EMI (inhibit ALE, slew rate controlled outputs, and 6-clock mode)
- Wake-up from Power Down by an external interrupt

80C51 8-bit microcontroller family 16 KB OTP/ROM, 512B RAM, low voltage (2.7 to 5.5 V), low power, high speed (30/33 MHz), two 400KB I²C interfaces

P8xC660X2/661X2

SELECTION TABLE

| Type | Memory | | | | Timers | | | | Serial Interfaces | | | | ADC bits/ch. | I/O Pins | Interrupts (Ext.)/Levels | Program Security | Default Clock Rate | Optional Clock Rate | Reset active low/high? | Max. Freq. at 6-clk / 12-clk (MHz) | Freq. Range at 3V (MHz) (6-clk / 12-clk) | Freq. Range at 5V (MHz) (6-clk / 12-clk) |
|-----------|--------|-----|-----|-------|-------------|-----|-----|----|-------------------|------------------|-----|-----|--------------|----------|--------------------------|------------------|--------------------|---------------------|------------------------|------------------------------------|--|--|
| | RAM | ROM | OTP | Flash | # of Timers | PWM | PCA | WD | UART | I ² C | CAN | SPI | | | | | | | | | | |
| P87C660X2 | 512B | – | 16K | – | 4 | √ | √ | √ | √ | 1 | – | – | – | 32 | 7(2)/4 | √ | 12-clk | 6-clk | H | 30/33 | 0-16 | 0-30/33 |
| P83C660X2 | 512B | 16K | – | – | 4 | √ | √ | √ | √ | 1 | – | – | – | 32 | 7(2)/4 | √ | 12-clk | 6-clk | H | 30/33 | 0-16 | 0-30/33 |
| P87C661X2 | 512B | – | 16K | – | 4 | √ | √ | √ | √ | 2 | – | – | – | 32 | 7(2)/4 | √ | 12-clk | 6-clk | H | 30/33 | 0-16 | 0-30/33 |
| P83C661X2 | 512B | 16K | – | – | 4 | √ | √ | √ | √ | 2 | – | – | – | 32 | 7(2)/4 | √ | 12-clk | 6-clk | H | 30/33 | 0-16 | 0-30/33 |

ORDERING INFORMATION

| Type number | Package | | | Temp Range (°C) | | | |
|--------------|---------|-------|------|-----------------|--|----------|------------|
| | OTP | ROM | RAM | | | | |
| P83C660X2FA | – | 16 KB | 512B | PLCC44 | plastic leaded chip carrier; 44 leads | SOT187–2 | –40 to +85 |
| P83C660X2BBD | – | 16 KB | 512B | LQFP44 | plastic low profile quad flat package; 44 leads; body 10 × 10 × 1.4 mm | SOT389–1 | 0 to +70 |
| P87C660X2FA | 16 KB | – | 512B | PLCC44 | plastic leaded chip carrier; 44 leads | SOT187–2 | –40 to +85 |
| P87C660X2BBD | 16 KB | – | 512B | LQFP44 | plastic low profile quad flat package; 44 leads; body 10 × 10 × 1.4 mm | SOT389–1 | 0 to +70 |
| P83C661X2FA | – | 16 KB | 512B | PLCC44 | plastic leaded chip carrier; 44 leads | SOT187–2 | –40 to +85 |
| P83C661X2BBD | – | 16 KB | 512B | LQFP44 | plastic low profile quad flat package; 44 leads; body 10 × 10 × 1.4 mm | SOT389–1 | 0 to +70 |
| P87C661X2FA | 16 KB | – | 512B | PLCC44 | plastic leaded chip carrier; 44 leads | SOT187–2 | –40 to +85 |
| P87C661X2BBD | 16 KB | – | 512B | LQFP44 | plastic low profile quad flat package; 44 leads; body 10 × 10 × 1.4 mm | SOT389–1 | 0 to +70 |

80C51 8-bit microcontroller family 16 KB OTP/ROM, 512B RAM, low voltage (2.7 to 5.5 V), low power, high speed (30/33 MHz), two 400KB I²C interfaces

P8xC660X2/661X2

BLOCK DIAGRAM 1

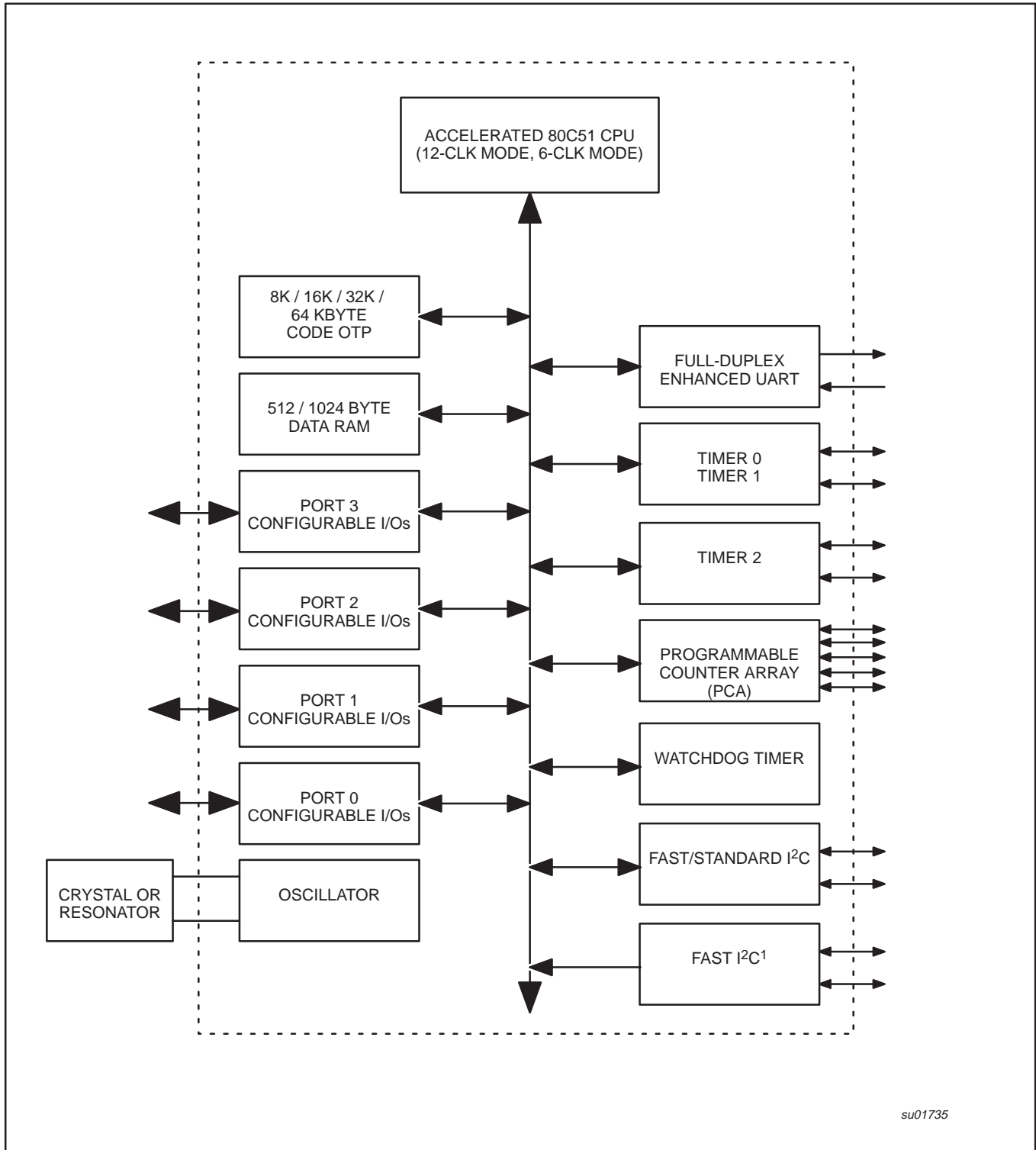

su01735

1. 2nd I²C on P8xC661X2 only.

80C51 8-bit microcontroller family 16 KB OTP/ROM, 512B RAM, low voltage (2.7 to 5.5 V), low power, high speed (30/33 MHz), two 400KB I²C interfaces

P8xC660X2/661X2

BLOCK DIAGRAM (CPU-ORIENTED)

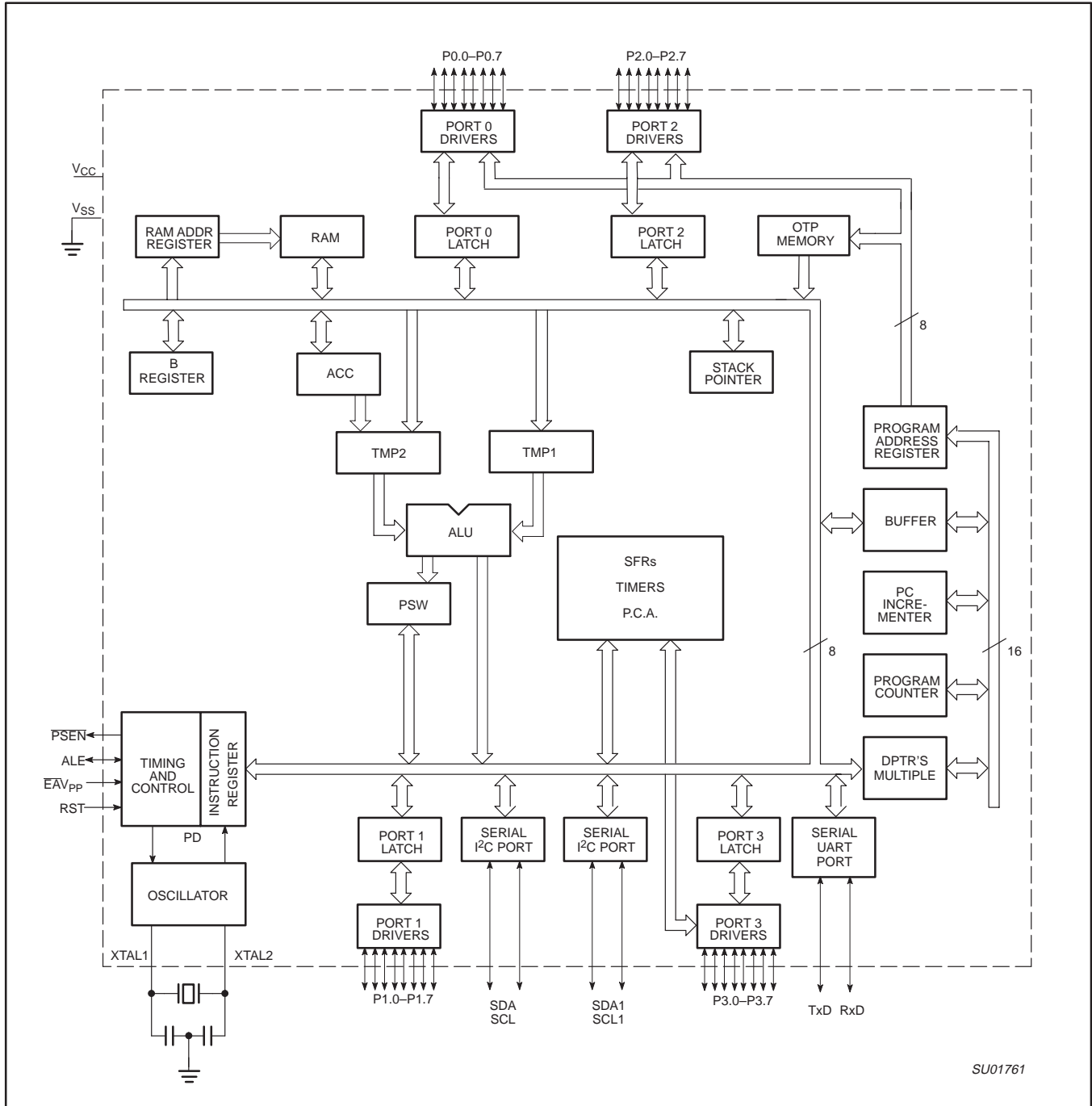

80C51 8-bit microcontroller family 16 KB OTP/ROM, 512B RAM, low voltage (2.7 to 5.5 V), low power, high speed (30/33 MHz), two 400KB I²C interfaces

P8xC660X2/661X2

LOGIC SYMBOL

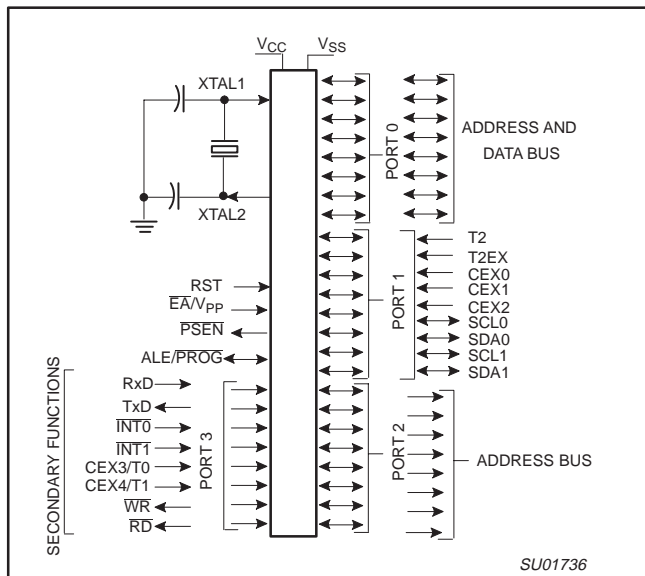

SU01736

Plastic Quad Flat Pack

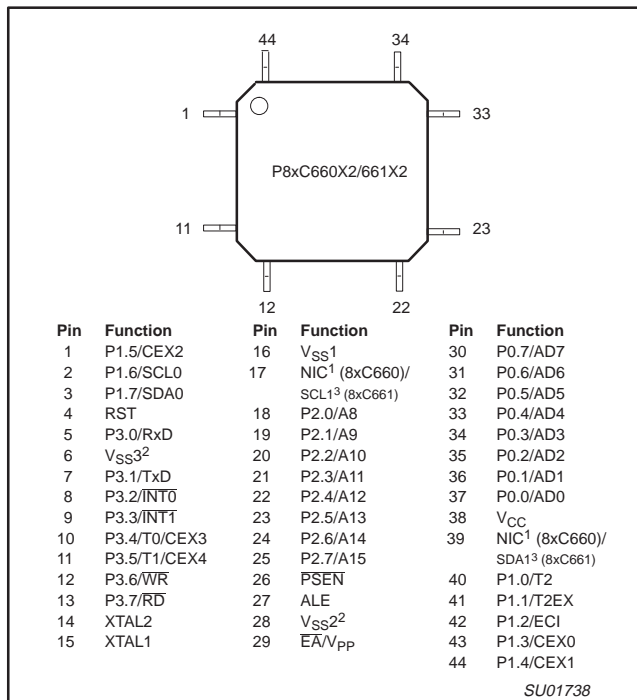

SU01738

1. No internal connection
2. May be left open, but it is recommended to connect V_{SS2} and V_{SS3} to GND to improve EMC performance
3. P8xC661X2 devices only

PINNING

Plastic Leaded Chip Carrier

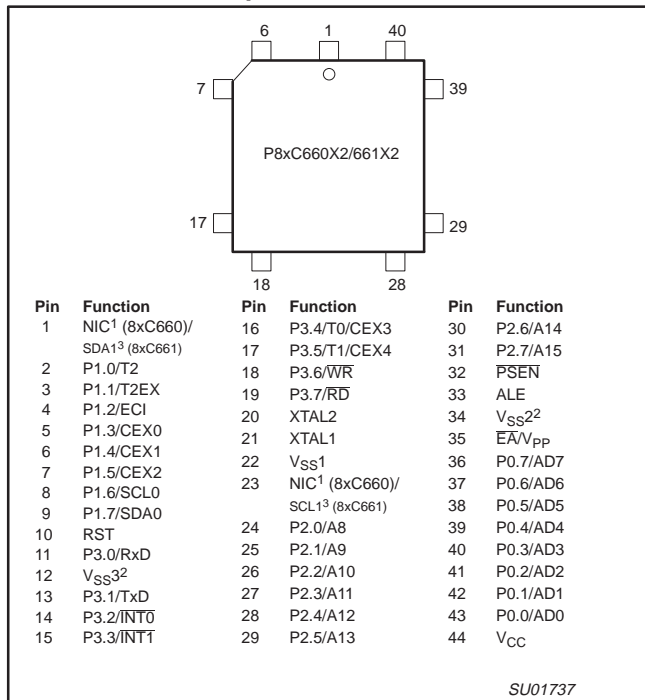

SU01737

1. No internal connection
2. May be left open, but it is recommended to connect V_{SS2} and V_{SS3} to GND to improve EMC performance
3. P8xC661X2 devices only, these pins are open-drain and have the same electrical characteristics as P1.6 and P1.7

80C51 8-bit microcontroller family 16 KB OTP/ROM, 512B RAM, low voltage (2.7 to 5.5 V), low power, high speed (30/33 MHz), two 400KB I²C interfaces

P8xC660X2/661X2

PIN DESCRIPTIONS

| MNEMONIC | PIN NUMBER | | TYPE | NAME AND FUNCTION | | | |
|------------------------|--------------|---------------|--|--|----|-----|--|
| | PLCC | LQFP | | | | | |
| V _{SS1} | 22 | 16 | I | Ground: 0 V reference. | | | |
| V _{SS2} | 34 | 28 | I | Ground: Additional ground pin (may be left open). | | | |
| V _{SS3} | 12 | 6 | I | Ground: Additional ground pin (may be left open). | | | |
| V _{CC} | 44 | 38 | I | Power Supply: This is the power supply voltage for normal, idle, and power-down operation. | | | |
| P0.0–0.7 ² | 43–36 | 37–30 | I/O | Port 0: Port 0 is an open-drain, bidirectional I/O port. Port 0 pins that have 1s written to them float and can be used as high-impedance inputs. Port 0 is also the multiplexed low-order address and data bus during accesses to external program and data memory. In this application, it uses strong internal pull-ups when emitting 1s. | | | |
| P1.0–P1.7 ² | 2–9 | 40–44, 1–3 | I/O | Port 1: Port 1 is an 8-bit bidirectional I/O port with internal pull-ups on all pins. Port 1 pins that have 1s written to them are pulled HIGH by the internal pull-ups and can be used as inputs. As inputs, port 1 pins that are externally pulled LOW will source current because of the internal pull-ups. (See DC Electrical Characteristics: I _{IL}). | | | |
| | | | | Alternate functions for P8xC660X2/661X2 Port 1 include: | | | |
| | | | | 2 | 40 | I/O | T2 (P1.0): Timer/Counter 2 external count input/Clockout (see Programmable Clock-Out) |
| | | | | 3 | 41 | I | T2EX (P1.1): Timer/Counter 2 Reload/Capture/Direction Control |
| | | | | 4 | 42 | I | ECI (P1.2): External Clock Input to the PCA |
| | | | | 5 | 43 | I/O | CEX0 (P1.3): Capture/Compare External I/O for PCA module 0 |
| | | | | 6 | 44 | I/O | CEX1 (P1.4): Capture/Compare External I/O for PCA module 1 |
| | | | | 7 | 1 | I/O | CEX2 (P1.5): Capture/Compare External I/O for PCA module 2 |
| | | | | 8 | 2 | I/O | SCL (P1.6): I ² C bus clock line (open drain) |
| 9 | 3 | I/O | SCL (P1.7): I ² C bus data line (open drain) | | | | |
| P2.0–P2.7 ² | 24–31 | 18–25 | I/O | Port 2: Port 2 is an 8-bit bidirectional I/O port with internal pull-ups. Port 2 pins that have 1s written to them are pulled HIGH by the internal pull-ups and can be used as inputs. As inputs, port 2 pins that are externally being pulled LOW will source current because of the internal pull-ups. (See DC Electrical Characteristics: I _{IL}). Port 2 emits the high-order address byte during fetches from external program memory and during accesses to external data memory that use 16-bit addresses (MOVX @DPTR). In this application, it uses strong internal pull-ups when emitting 1s. During accesses to external data memory that use 8-bit addresses (MOV @Ri), port 2 emits the contents of the P2 special function register. | | | |
| P3.0–P3.7 ² | 11, 13–19 | 5, 7–13 | I/O | Port 3: Port 3 is an 8-bit bidirectional I/O port with internal pull-ups. Port 3 pins that have 1s written to them are pulled HIGH by the internal pull-ups and can be used as inputs. As inputs, port 3 pins that are externally being pulled LOW will source current because of the pull-ups. (See DC Electrical Characteristics: I _{IL}). Port 3 also serves the special features of the P8xC660X2/661X2, as listed below: | | | |
| | | | | 11 | 5 | I | RxD (P3.0): Serial input port |
| | | | | 13 | 7 | O | TxD (P3.1): Serial output port |
| | | | | 14 | 8 | I | INT0 (P3.2): External interrupt 0 |
| | | | | 15 | 9 | I | INT1 (P3.3): External interrupt 1 |
| | | | | 16 | 10 | I | CEX3/T0 (P3.4): Timer 0 external input; capture/compare external I/O for PCA module 3 |
| | | | | 17 | 11 | I | CEX4/T1 (P3.5): Timer 1 external input; capture/compare external I/O for PCA module 4 |
| | | | | 18 | 12 | O | WR (P3.6): External data memory write strobe |
| | | | | 19 | 13 | O | RD (P3.7): External data memory read strobe |
| | | | | RST ² | 10 | 4 | I |
| SCL1 | 23 | 17 | I/O | Second I ² C bus clock line (open drain) (P8xC661X2) | | | |
| SDA1 | 1 | 39 | I/O | Second I ² C bus data line (open drain) (P8xC661X2) | | | |

80C51 8-bit microcontroller family 16 KB OTP/ROM, 512B RAM, low voltage (2.7 to 5.5 V), low power, high speed (30/33 MHz), two 400KB I²C interfaces

P8xC660X2/661X2

| MNEMONIC | PIN NUMBER | | TYPE | NAME AND FUNCTION |
|------------------------------|------------|------|------|--|
| | PLCC | LQFP | | |
| ALE ² | 33 | 27 | O | Address Latch Enable: Output pulse for latching the LOW byte of the address during an access to external memory. In normal operation, ALE is emitted twice every machine cycle, and can be used for external timing or clocking. Note that one ALE pulse is skipped during each access to external data memory. ALE can be disabled by setting SFR auxiliary.0. With this bit set, ALE will be active only during a MOVX instruction. |
| PSEN ² | 32 | 26 | O | Program Store Enable: The read strobe to external program memory. When executing code from the external program memory, PSEN is activated twice each machine cycle, except that two PSEN activations are skipped during each access to external data memory. PSEN is not activated during fetches from internal program memory. |
| \overline{EA} ² | 35 | 29 | I | External Access Enable/Programming Supply Voltage: \overline{EA} must be externally held LOW to enable the device to fetch code from external program memory locations. If \overline{EA} is held HIGH, the device executes from internal program memory. The value on the \overline{EA} pin is latched when RST is released and any subsequent changes have no effect. This pin also receives the programming supply voltage (V_{PP}) during programming. |
| XTAL1 | 21 | 15 | I | Crystal 1: Input to the inverting oscillator amplifier and input to the internal clock generator circuits. |
| XTAL2 | 20 | 14 | O | Crystal 2: Output from the inverting oscillator amplifier. |

NOTE:

1. To avoid "latch-up" effect at power-on, the voltage on any pin (other than EA) must not be higher than $V_{CC} + 0.5$ V or less than $V_{SS} - 0.5$ V.
2. The pins are designed for test mode also.

80C51 8-bit microcontroller family 16 KB OTP/ROM, 512B RAM, low voltage (2.7 to 5.5 V), low power, high speed (30/33 MHz), two 400KB I²C interfaces

P8xC660X2/661X2

SPECIAL FUNCTION REGISTERS

| SYMBOL | DESCRIPTION | DIRECT ADDRESS | BIT ADDRESS, SYMBOL, OR ALTERNATIVE PORT FUNCTION | | | | | | | | RESET VALUE |
|---------|-------------------------|----------------|---|------|------|------|------|------|--------|------|-------------|
| | | | MSB | | | | LSB | | | | |
| ACC* | Accumulator | E0H | E7 | E6 | E5 | E4 | E3 | E2 | E1 | E0 | 00H |
| AUXR# | Auxiliary | 8EH | – | – | SRD | – | FME | – | EXTRAM | AO | xxxx0x10B |
| AUXR1# | Auxiliary 1 | A2H | – | – | – | LPEP | GPS | 0 | – | DPS | xxxx00x0B |
| B* | B register | F0H | F7 | F6 | F5 | F4 | F3 | F2 | F1 | F0 | 00H |
| CCAP0H# | Module 0 Capture High | FAH | | | | | | | | | xxxxxxxB |
| CCAP1H# | Module 1 Capture High | FBH | | | | | | | | | xxxxxxxB |
| CCAP2H# | Module 2 Capture High | FCH | | | | | | | | | xxxxxxxB |
| CCAP3H# | Module 3 Capture High | FDH | | | | | | | | | xxxxxxxB |
| CCAP4H# | Module 4 Capture High | FEH | | | | | | | | | xxxxxxxB |
| CCAP0L# | Module 0 Capture Low | EAH | | | | | | | | | xxxxxxxB |
| CCAP1L# | Module 1 Capture Low | EBH | | | | | | | | | xxxxxxxB |
| CCAP2L# | Module 2 Capture Low | ECH | | | | | | | | | xxxxxxxB |
| CCAP3L# | Module 3 Capture Low | EDH | | | | | | | | | xxxxxxxB |
| CCAP4L# | Module 4 Capture Low | EEH | | | | | | | | | xxxxxxxB |
| CCAPM0# | Module 0 Mode | C2H | – | ECOM | CAPP | CAPN | MAT | TOG | PWM | ECCF | x0000000B |
| CCAPM1# | Module 1 Mode | C3H | – | ECOM | CAPP | CAPN | MAT | TOG | PWM | ECCF | x0000000B |
| CCAPM2# | Module 2 Mode | C4H | – | ECOM | CAPP | CAPN | MAT | TOG | PWM | ECCF | x0000000B |
| CCAPM3# | Module 3 Mode | C5H | – | ECOM | CAPP | CAPN | MAT | TOG | PWM | ECCF | x0000000B |
| CCAPM4# | Module 4 Mode | C6H | – | ECOM | CAPP | CAPN | MAT | TOG | PWM | ECCF | x0000000B |
| CCON*# | PCA Counter Control | C0H | C7 | C6 | C5 | C4 | C3 | C2 | C1 | C0 | 00x00000B |
| CH# | PCA Counter High | F9H | CF | CR | – | CCF4 | CCF3 | CCF2 | CCF1 | CCF0 | 00H |
| CL# | PCA Counter Low | E9H | | | | | | | | | 00H |
| CMOD# | PCA Counter Mode | C1H | CIDL | WDTE | – | – | – | CPS1 | CPS0 | ECF | 00xxx000B |
| CKCON | Clock control | 8FH | – | – | – | – | – | – | – | X2 | xxxxxx1B |
| DPTR: | Data Pointer (2 bytes) | | | | | | | | | | |
| DPH | Data Pointer High | 83H | | | | | | | | | 00H |
| DPL | Data Pointer Low | 82H | | | | | | | | | 00H |
| IEN0* | Interrupt Enable 0 | A8H | AF | AE | AD | AC | AB | AA | A9 | A8 | 00000000B |
| IEN1* | Interrupt Enable 1 | E8H | EA | EC | ES1 | ES0 | ET1 | EX1 | ET0 | EX0 | 00000000B |
| IP*# | Interrupt Priority | B8H | – | – | – | – | – | – | ES2 | ET2 | xxxxxx00B |
| IPH# | Interrupt Priority High | B7H | BF | BE | BD | BC | BB | BA | B9 | B8 | 00000000B |
| P0* | Port 0 | 80H | PT2 | PPC | PS1 | PS0 | PT1 | PX1 | PT0 | PX0 | 00000000B |
| P1*# | Port 1 | 90H | B7 | B6 | B5 | B4 | B3 | B2 | B1 | B0 | 00000000B |
| P2* | Port 2 | A0H | PT2H | PPCH | PS1H | PS0H | PT1H | PX1H | PT0H | PX0H | 00000000B |
| | | | 87 | 86 | 85 | 84 | 83 | 82 | 81 | 80 | |
| | | | AD7 | AD6 | AD5 | AD4 | AD3 | AD2 | AD1 | AD0 | FFH |
| | | | 97 | 96 | 95 | 94 | 93 | 92 | 91 | 90 | |
| | | | SDA | SCL | CEX2 | CEX1 | CEX0 | ECI | T2EX | T2 | FFH |
| | | | A7 | A6 | A5 | A4 | A3 | A2 | A1 | A0 | |
| | | | AD15 | AD14 | AD13 | AD12 | AD11 | AD10 | AD9 | AD8 | FFH |
| | | | B7 | B6 | B5 | B4 | B3 | B2 | B1 | B0 | |

* SFRs are bit addressable.
 # SFRs are modified from or added to the 80C51 SFRs.
 – Reserved bits.
 1. Reset value depends on reset source.
 2. 8xC661X2 only.

80C51 8-bit microcontroller family 16 KB OTP/ROM, 512B RAM, low voltage (2.7 to 5.5 V), low power, high speed (30/33 MHz), two 400KB I²C interfaces

P8xC660X2/661X2

SPECIAL FUNCTION REGISTERS (Continued)

| SYMBOL | DESCRIPTION | DIRECT ADDRESS | BIT ADDRESS, SYMBOL, OR ALTERNATIVE PORT FUNCTION | | | | | | | | RESET VALUE |
|--------------------|---------------------------------|----------------|---|-------|---------|---------|-------|------|------|-----------|-------------|
| | | | MSB | | | | LSB | | | | |
| P3* | Port 3 | B0H | RD | WR | T1/CEX4 | T0/CEX3 | INT1 | INT0 | TxD | RxD | FFH |
| PCON# ¹ | Power Control | 87H | SMOD1 | SMOD0 | – | POF | GF1 | GF0 | PD | IDL | 00xx0000B |
| | | | D7 | D6 | D5 | D4 | D3 | D2 | D1 | D0 | |
| PSW | Program Status Word | D0H | CY | AC | F0 | RS1 | RS0 | OV | F1 | P | 000000x0B |
| RCAP2H# | Timer 2 Capture High | CBH | | | | | | | | | 00H |
| RCAP2L# | Timer 2 Capture Low | CAH | | | | | | | | | 00H |
| SADDR# | Slave Address | A9H | | | | | | | | | 00H |
| SADEN# | Slave Address Mask | B9H | | | | | | | | | 00H |
| SBUF | Serial Data Buffer | 99H | | | | | | | | | xxxxxxx0B |
| SCON* | Serial Control | 98H | 9F | 9E | 9D | 9C | 9B | 9A | 99 | 98 | 00H |
| | | SM0/FE | SM1 | SM2 | REN | TB8 | RB8 | TI | RI | | |
| SP | Stack Pointer | 81H | | | | | | | | | 07H |
| | | 8F | | | | | | | | | 8E |
| TCON* | Timer Control | 88H | TF1 | TR1 | TF0 | TR0 | IE1 | IT1 | IE0 | IT0 | 00H |
| | | | CF | CE | CD | CC | CB | CA | C9 | C8 | |
| T2CON* | Timer 2 Control | C8H | TF2 | EXF2 | RCLK | TCLK | EXEN2 | TR2 | C/T2 | CP/RL2 | 00H |
| T2MOD# | Timer 2 Mode Control | C9H | – | – | – | – | – | T2OE | DCEN | xxxxxx00B | |
| TH0 | Timer High 0 | 8CH | | | | | | | | | 00H |
| TH1 | Timer High 1 | 8DH | | | | | | | | | 00H |
| TH2# | Timer High 2 | CDH | | | | | | | | | 00H |
| TL0 | Timer Low 0 | 8AH | | | | | | | | | 00H |
| TL1 | Timer Low 1 | 8BH | | | | | | | | | 00H |
| TL2# | Timer Low 2 | CCH | | | | | | | | | 00H |
| TMOD | Timer Mode | 89H | | | | | | | | | GATE |
| S1CON | I ² C Control | D8H | CR2 | ENA1 | STA | STO | SI | AA | CR1 | CR0 | 00H |
| S1STA | I ² C STATUS | D9H | SC4 | SC3 | SC2 | SC1 | SC0 | 0 | 0 | 0 | F8H |
| S1DAT | I ² C DATA | DAH | | | | | | | | | 00H |
| S1ADR | I ² C ADDRESS | DBH | | | | | | | | | GC |
| S2CON ² | Second I ² C control | F8H | CR2 | ENA1 | STA | STO | SI | AA | CR1 | CR0 | 00H |
| S2STA ² | Second I ² C | F1H | SC4 | SC3 | SC2 | SC1 | SC0 | 0 | 0 | 0 | F8H |
| S2DAT ² | Second I ² C | F2H | | | | | | | | | 00H |
| S2ADR ² | Second I ² C | F3H | | | | | | | | | GC |
| S2IST ² | Second I ² C | F4H | | | | | | | | | 00H |
| IP1 ² | Interrupt priority 1 | E7H | | | | | | | | | PS2 |
| IP1H ² | | F7H | | | | | | | | | PS2H |
| WDTRST | Watchdog Timer Reset | A6H | | | | | | | | | |

* SFRs are bit addressable.
 # SFRs are modified from or added to the 80C51 SFRs.
 – Reserved bits.
 1. Reset value depends on reset source.
 2. 8xC661X2 only.

80C51 8-bit microcontroller family 16 KB OTP/ROM, 512B RAM, low voltage (2.7 to 5.5 V), low power, high speed (30/33 MHz), two 400KB I²C interfaces

P8xC660X2/661X2

CLOCK CONTROL REGISTER (CKCON)

This device allows control of the 6-clock/12-clock mode by means of both an SFR bit (X2) and an OTP bit. The OTP clock control bit

OX2, when programmed by a parallel programmer (6-clock mode), supersedes the X2 bit (CKCON.0). The CKCON register is shown below in Figure 1.

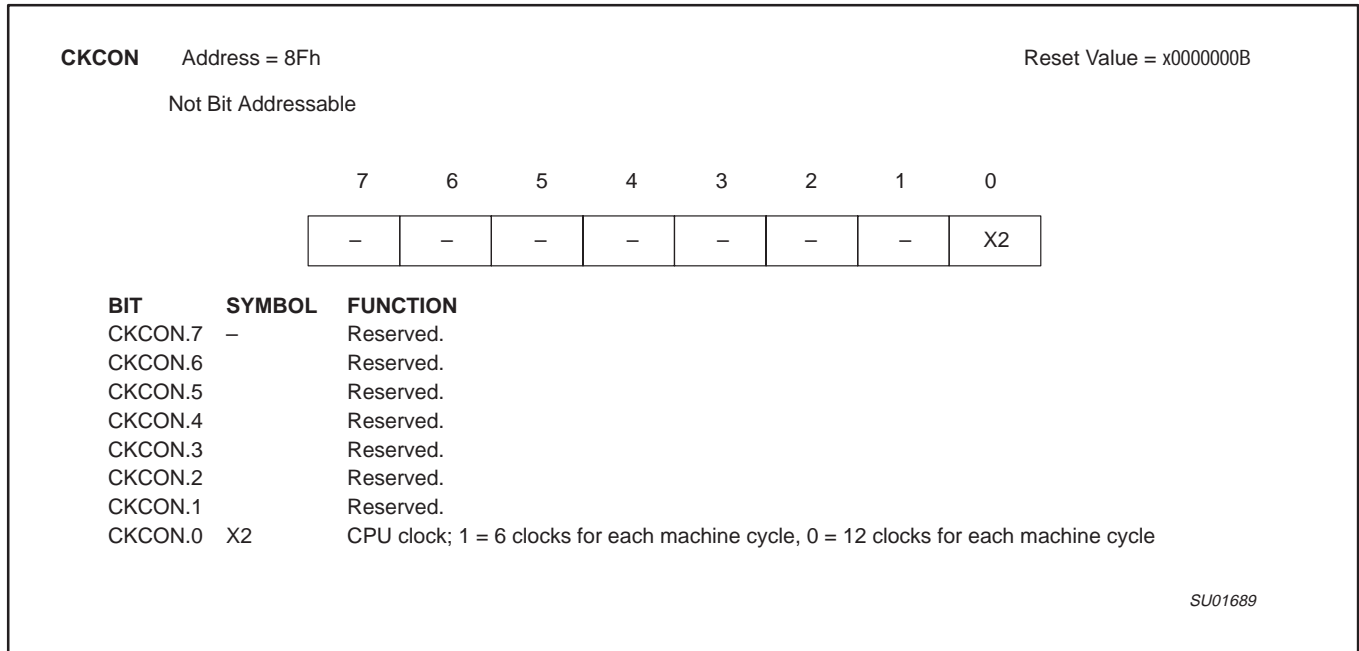

Figure 1. Clock control (CKCON) register

Also please note that the clock divider applies to the serial port for modes 0 & 2 (fixed baud rate modes). This is because modes 1 & 3 (variable baud rate modes) use either Timer 1 or Timer 2.

Below is the truth table for the CPU clock mode.

Table 1.

| OX2 clock mode bit (can only be set by parallel programmer) | X2 bit (CKCON.0) | CPU clock mode |
|---|---------------------|----------------------------|
| erased | 0 | 12-clock mode (default) |
| erased | 1 | 6-clock mode |
| programmed | X | 6-clock mode |

RESET

A reset is accomplished by holding the RST pin HIGH for at least two machine cycles (12 oscillator periods in 6-clock mode, or 24 oscillator periods in 12-clock mode), while the oscillator is running. To ensure a good power-on reset, the RST pin must be HIGH long enough to allow the oscillator time to start up (normally a few milliseconds) plus two machine cycles. At power-on, the voltage on V_{CC} and RST must come up at the same time for a proper start-up. Ports 1, 2, and 3 will asynchronously be driven to their reset condition when a voltage above V_{IH1} (min.) is applied to RST.

The value on the $\bar{E}A$ pin is latched when RST is deasserted and has no further effect.

80C51 8-bit microcontroller family 16 KB OTP/ROM, 512B RAM, low voltage (2.7 to 5.5 V), low power, high speed (30/33 MHz), two 400KB I²C interfaces

P8xC660X2/661X2

LOW POWER MODES

Stop Clock Mode

The static design enables the clock speed to be reduced down to 0 MHz (stopped). When the oscillator is stopped, the RAM and Special Function Registers retain their values. This mode allows step-by-step utilization and permits reduced system power consumption by lowering the clock frequency down to any value. For lowest power consumption the Power Down mode is suggested.

Idle Mode

In the idle mode (see Table 2), the CPU puts itself to sleep while all of the on-chip peripherals stay active. The instruction to invoke the idle mode is the last instruction executed in the normal operating mode before the idle mode is activated. The CPU contents, the on-chip RAM, and all of the special function registers remain intact during this mode. The idle mode can be terminated either by any enabled interrupt (at which time the process is picked up at the interrupt service routine and continued), or by a hardware reset which starts the processor in the same manner as a power-on reset.

Power-Down Mode

To save even more power, a Power Down mode (see Table 2) can be invoked by software. In this mode, the oscillator is stopped and the instruction that invoked Power Down is the last instruction executed. The on-chip RAM and Special Function Registers retain their values down to 2 V and care must be taken to return V_{CC} to the minimum specified operating voltages before the Power Down Mode is terminated.

Either a hardware reset or external interrupt can be used to exit from Power Down. Reset redefines all the SFRs but does not change the on-chip RAM. An external interrupt allows both the SFRs and the on-chip RAM to retain their values.

To properly terminate Power Down, the reset or external interrupt should not be executed before V_{CC} is restored to its normal operating level and must be held active long enough for the oscillator to restart and stabilize (normally less than 10 ms).

With an external interrupt, INT0 and INT1 must be enabled and configured as level-sensitive. Holding the pin LOW restarts the oscillator but bringing the pin back HIGH completes the exit. Once the interrupt is serviced, the next instruction to be executed after RETI will be the one following the instruction that put the device into Power Down.

LPEP

The EPROM array contains some analog circuits that are not required when V_{CC} is less than 3.6 V but are required for a V_{CC} greater than 3.6 V. The LPEP bit (AUXR.4), when set, will powerdown these analog circuits resulting in a reduced supply current. This bit should be set ONLY for applications that operate at a V_{CC} less than 4 V.

POWER-ON FLAG

The Power-On Flag (POF) is set by on-chip circuitry when the V_{CC} level on the P8xC66xX2 rises from 0 to 5 V. The POF bit can be set or cleared by software allowing a user to determine if the reset is the result of a power-on or a warm start after powerdown. The V_{CC} level must remain above 3 V for the POF to remain unaffected by the V_{CC} level.

Design Consideration

When the idle mode is terminated by a hardware reset, the device normally resumes program execution, from where it left off, up to two machine cycles before the internal reset algorithm takes control. On-chip hardware inhibits access to internal RAM in this event, but access to the port pins is not inhibited. To eliminate the possibility of an unexpected write when Idle is terminated by reset, the instruction following the one that invokes Idle should not be one that writes to a port pin or to external memory.

ONCE™ Mode

The ONCE (“On-Circuit Emulation”) Mode facilitates testing and debugging of systems without the device having to be removed from the circuit. The ONCE Mode is invoked by:

1. Pull ALE LOW while the device is in reset and $\overline{\text{PSEN}}$ is HIGH;
2. Hold ALE LOW as RST is deactivated.

While the device is in ONCE Mode, the Port 0 pins go into a float state, and the other port pins and ALE and $\overline{\text{PSEN}}$ are weakly pulled HIGH. The oscillator circuit remains active. While the device is in this mode, an emulator or test CPU can be used to drive the circuit. Normal operation is restored when a normal reset is applied.

Programmable Clock-Out

A 50% duty cycle clock can be programmed to come out on P1.0. This pin, besides being a regular I/O pin, has two alternate functions. It can be programmed:

1. to input the external clock for Timer/Counter 2, or
2. to output a 50% duty cycle clock ranging from 61 Hz to 4 MHz at a 16 MHz operating frequency in 12-clock mode (122 Hz to 8 MHz in 6-clock mode).

To configure the Timer/Counter 2 as a clock generator, bit C/T2 (in T2CON) must be cleared and bit T20E in T2MOD must be set. Bit TR2 (T2CON.2) also must be set to start the timer.

The Clock-Out frequency depends on the oscillator frequency and the reload value of Timer 2 capture registers (RCAP2H, RCAP2L) as shown in this equation:

$$n = \frac{\text{Oscillator Frequency}}{n \times (65536 - \text{RCAP2H, RCAP2L})}$$

n = 2 in 6-clock mode
4 in 12-clock mode

Where (RCAP2H,RCAP2L) = the content of RCAP2H and RCAP2L taken as a 16-bit unsigned integer.

In the Clock-Out mode Timer 2 roll-overs will not generate an interrupt. This is similar to when it is used as a baud-rate generator. It is possible to use Timer 2 as a baud-rate generator and a clock generator simultaneously. Note, however, that the baud-rate and the Clock-Out frequency will be the same.

80C51 8-bit microcontroller family 16 KB OTP/ROM, 512B RAM, low voltage (2.7 to 5.5 V), low power, high speed (30/33 MHz), two 400KB I²C interfaces

P8xC660X2/661X2

Table 2. External Pin Status During Idle and Power-Down Mode

| MODE | PROGRAM MEMORY | ALE | $\overline{\text{PSEN}}$ | PORT 0 | PORT 1 | PORT 2 | PORT 3 |
|------------|----------------|-----|--------------------------|--------|--------|---------|--------|
| Idle | Internal | 1 | 1 | Data | Data | Data | Data |
| Idle | External | 1 | 1 | Float | Data | Address | Data |
| Power-down | Internal | 0 | 0 | Data | Data | Data | Data |
| Power-down | External | 0 | 0 | Float | Data | Data | Data |

TIMER 0 AND TIMER 1 OPERATION

Timer 0 and Timer 1

The "Timer" or "Counter" function is selected by control bits C/T in the Special Function Register TMOD. These two Timer/Counters have four operating modes, which are selected by bit-pairs (M1, M0) in TMOD. Modes 0, 1, and 2 are the same for both Timers/Counters. Mode 3 is different. The four operating modes are described in the following text.

Mode 0

Putting either Timer into Mode 0 makes it look like an 8048 Timer, which is an 8-bit Counter with a divide-by-32 prescaler. Figure 3 shows the Mode 0 operation.

In this mode, the Timer register is configured as a 13-bit register. As the count rolls over from all 1s to all 0s, it sets the Timer interrupt flag TFn. The counted input is enabled to the Timer when TRn = 1 and either GATE = 0 or $\overline{\text{INTn}}$ = 1. (Setting GATE = 1 allows the Timer to be controlled by external input $\overline{\text{INTn}}$, to facilitate pulse width measurements). TRn is a control bit in the Special Function Register TCON (Figure 4).

The 13-bit register consists of all 8 bits of THn and the lower 5 bits of TLn. The upper 3 bits of TLn are indeterminate and should be ignored. Setting the run flag (TRn) does not clear the registers.

Mode 0 operation is the same for Timer 0 as for Timer 1. There are two different GATE bits, one for Timer 1 (TMOD.7) and one for Timer 0 (TMOD.3).

Mode 1

Mode 1 is the same as Mode 0, except that the Timer register is being run with all 16 bits.

Mode 2

Mode 2 configures the Timer register as an 8-bit Counter (TLn) with automatic reload, as shown in Figure 5. Overflow from TLn not only sets TFn, but also reloads TLn with the contents of THn, which is preset by software. The reload leaves THn unchanged.

Mode 2 operation is the same for Timer 0 as for Timer 1.

Mode 3

Timer 1 in Mode 3 simply holds its count. The effect is the same as setting TR1 = 0.

Timer 0 in Mode 3 establishes TL0 and TH0 as two separate counters. The logic for Mode 3 on Timer 0 is shown in Figure 6. TL0 uses the Timer 0 control bits: C/T, GATE, TR0, and TF0 as well as pin $\overline{\text{INT0}}$. TH0 is locked into a timer function (counting machine cycles) and takes over the use of TR1 and TF1 from Timer 1. Thus, TH0 now controls the "Timer 1" interrupt.

Mode 3 is provided for applications requiring an extra 8-bit timer on the counter. With Timer 0 in Mode 3, an 80C51 can look like it has three Timer/Counters. When Timer 0 is in Mode 3, Timer 1 can be turned on and off by switching it out of and into its own Mode 3, or can still be used by the serial port as a baud rate generator, or in fact, in any application not requiring an interrupt.

80C51 8-bit microcontroller family 16 KB OTP/ROM, 512B RAM, low voltage (2.7 to 5.5 V), low power, high speed (30/33 MHz), two 400KB I²C interfaces

P8xC660X2/661X2

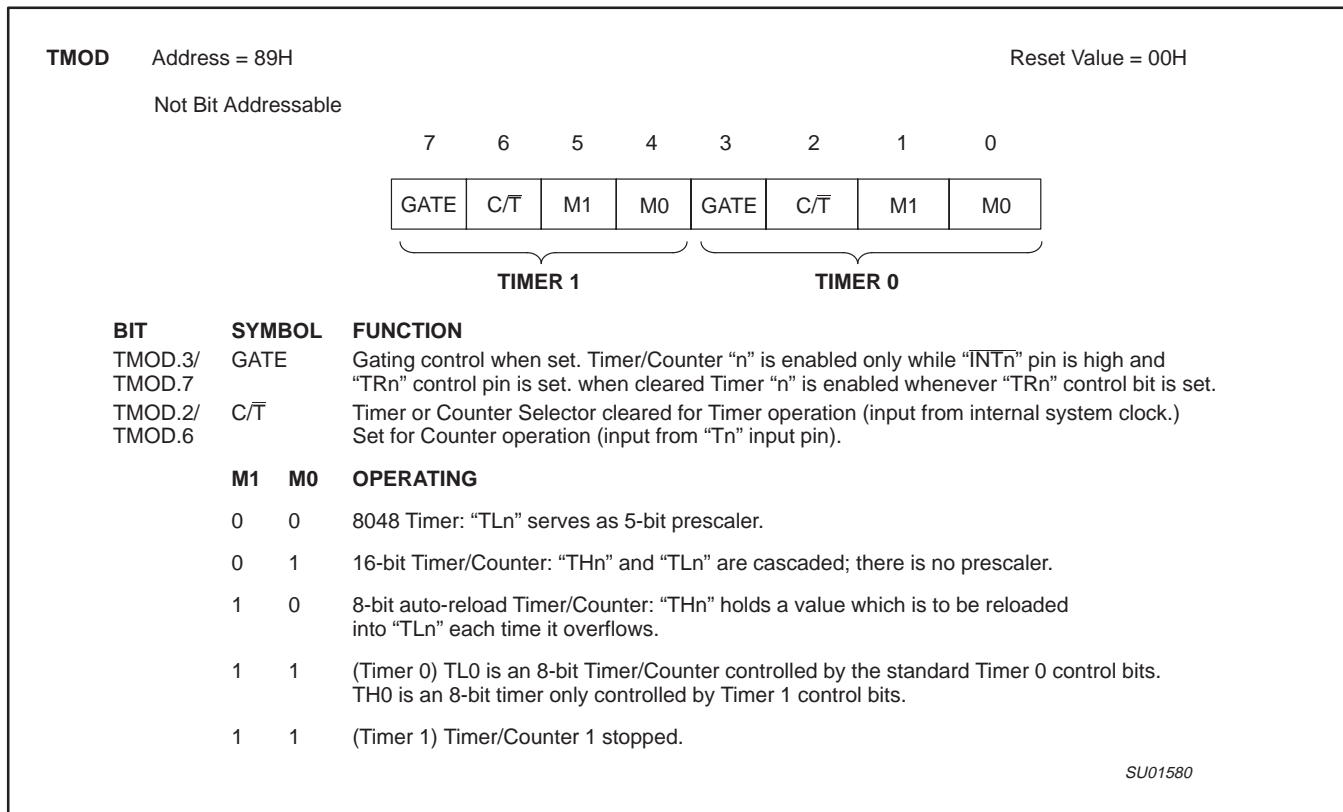

Figure 2. Timer/Counter 0/1 Mode Control (TMOD) Register

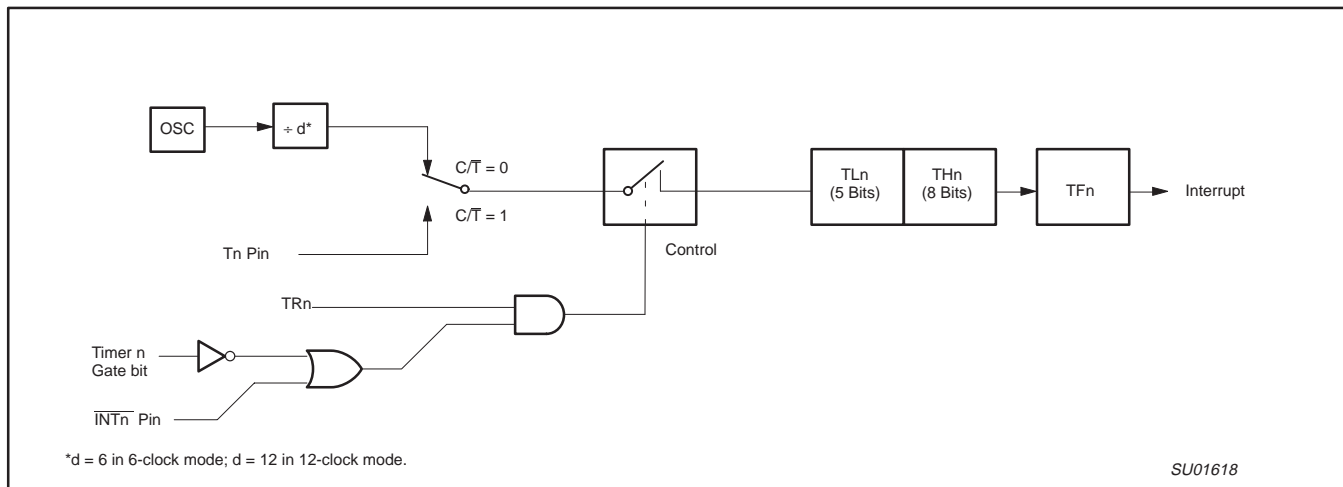

Figure 3. Timer/Counter 0/1 Mode 0: 13-Bit Timer/Counter

80C51 8-bit microcontroller family 16 KB OTP/ROM, 512B RAM, low voltage (2.7 to 5.5 V), low power, high speed (30/33 MHz), two 400KB I²C interfaces

P8xC660X2/661X2

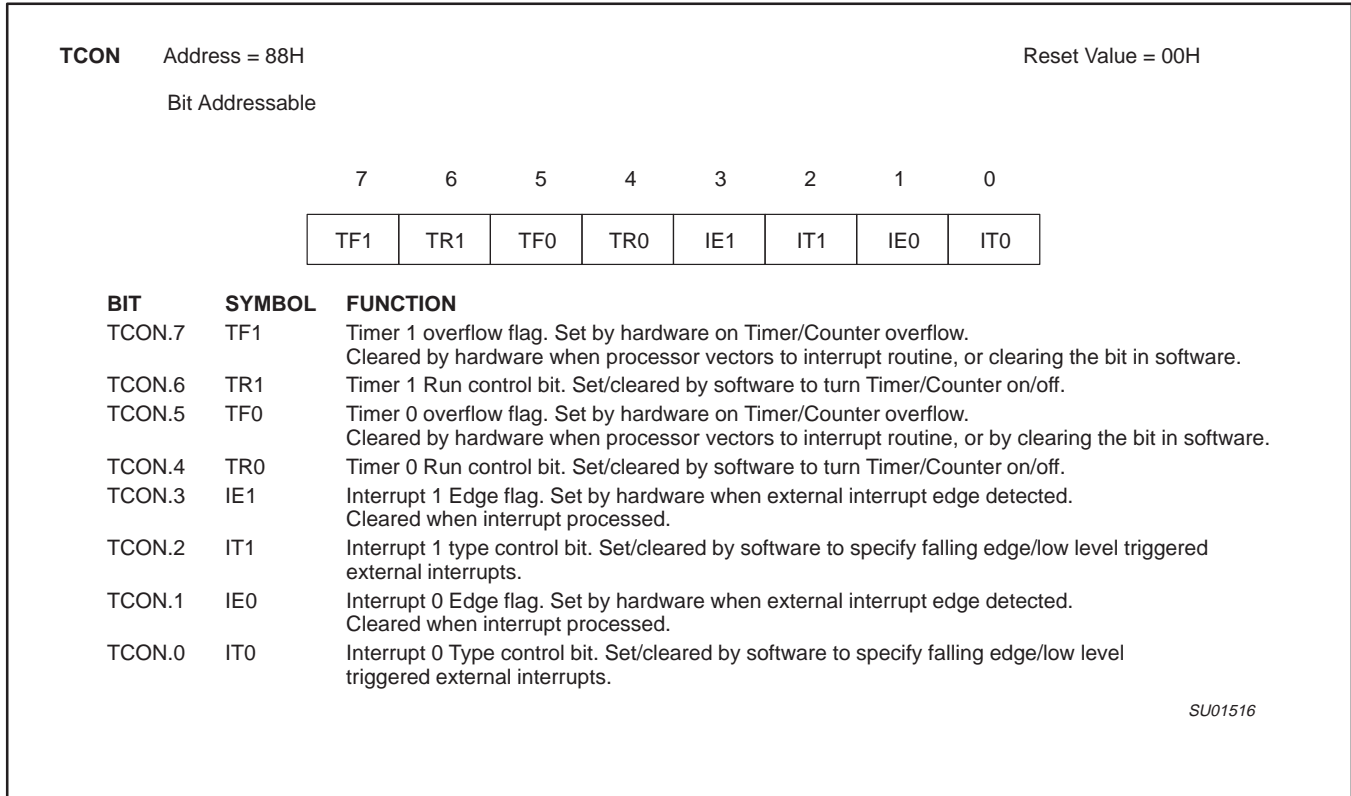

Figure 4. Timer/Counter 0/1 Control (TCON) Register

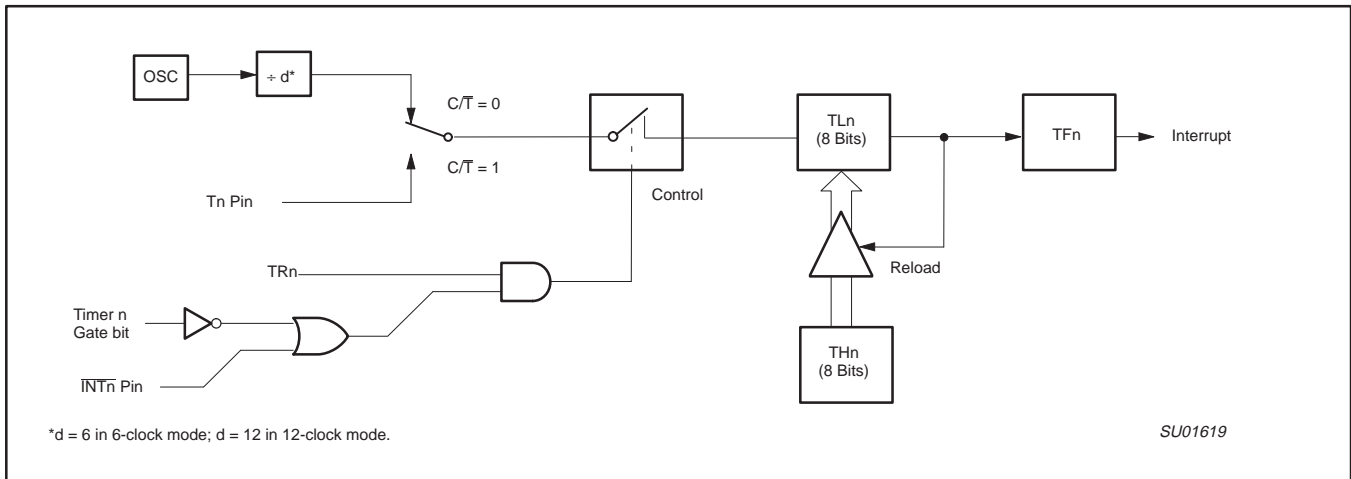

Figure 5. Timer/Counter 0/1 Mode 2: 8-Bit Auto-Reload

80C51 8-bit microcontroller family 16 KB OTP/ROM, 512B RAM, low voltage (2.7 to 5.5 V), low power, high speed (30/33 MHz), two 400KB I²C interfaces

P8xC660X2/661X2

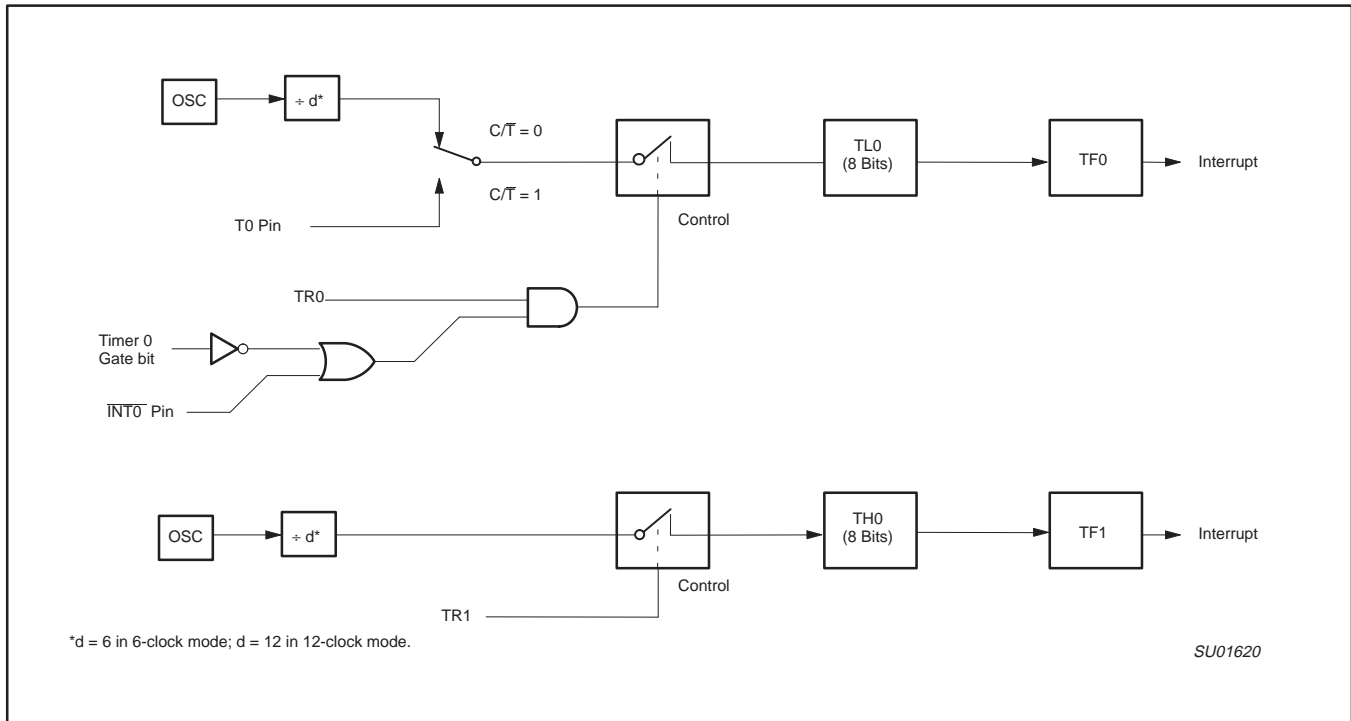

Figure 6. Timer/Counter 0 Mode 3: Two 8-Bit Counters

80C51 8-bit microcontroller family 16 KB OTP/ROM, 512B RAM, low voltage (2.7 to 5.5 V), low power, high speed (30/33 MHz), two 400KB I²C interfaces

P8xC660X2/661X2

TIMER 2 OPERATION

Timer 2

Timer 2 is a 16-bit Timer/Counter which can operate as either an event timer or an event counter, as selected by C/T2 in the special function register T2CON (see Figure 1). Timer 2 has three operating modes: Capture, Auto-reload (up or down counting), and Baud Rate Generator, which are selected by bits in the T2CON as shown in Table 3.

Capture Mode

In the capture mode there are two options which are selected by bit EXEN2 in T2CON. If EXEN2=0, then timer 2 is a 16-bit timer or counter (as selected by C/T2 in T2CON) which, upon overflowing sets bit TF2, the timer 2 overflow bit. This bit can be used to generate an interrupt (by enabling the Timer 2 interrupt bit in the IE register). If EXEN2= 1, Timer 2 operates as described above, but with the added feature that a 1- to -0 transition at external input T2EX causes the current value in the Timer 2 registers, TL2 and TH2, to be captured into registers RCAP2L and RCAP2H, respectively. In addition, the transition at T2EX causes bit EXF2 in T2CON to be set, and EXF2 like TF2 can generate an interrupt (which vectors to the same location as Timer 2 overflow interrupt. The Timer 2 interrupt service routine can interrogate TF2 and EXF2 to determine which event caused the interrupt). The capture mode is illustrated in Figure 2 (There is no reload value for TL2 and TH2 in this mode. Even when a capture event occurs from T2EX, the counter keeps on counting T2EX pin transitions or osc/6 pulses (osc/12 in 12-clock mode).).

Auto-Reload Mode (Up or Down Counter)

In the 16-bit auto-reload mode, Timer 2 can be configured (as either a timer or counter [C/T2 in T2CON]) then programmed to count up or down. The counting direction is determined by bit DCEN (Down

Counter Enable) which is located in the T2MOD register (see Figure 3). When reset is applied the DCEN=0 which means Timer 2 will default to counting up. If DCEN bit is set, Timer 2 can count up or down depending on the value of the T2EX pin.

Figure 4 shows Timer 2 which will count up automatically since DCEN=0. In this mode there are two options selected by bit EXEN2 in T2CON register. If EXEN2=0, then Timer 2 counts up to 0FFFFH and sets the TF2 (Overflow Flag) bit upon overflow. This causes the Timer 2 registers to be reloaded with the 16-bit value in RCAP2L and RCAP2H. The values in RCAP2L and RCAP2H are preset by software means.

If EXEN2=1, then a 16-bit reload can be triggered either by an overflow or by a 1-to-0 transition at input T2EX. This transition also sets the EXF2 bit. The Timer 2 interrupt, if enabled, can be generated when either TF2 or EXF2 are 1.

In Figure 5 DCEN=1 which enables Timer 2 to count up or down. This mode allows pin T2EX to control the direction of count. When a logic 1 is applied at pin T2EX Timer 2 will count up. Timer 2 will overflow at 0FFFFH and set the TF2 flag, which can then generate an interrupt, if the interrupt is enabled. This timer overflow also causes the 16-bit value in RCAP2L and RCAP2H to be reloaded into the timer registers TL2 and TH2.

When a logic 0 is applied at pin T2EX this causes Timer 2 to count down. The timer will underflow when TL2 and TH2 become equal to the value stored in RCAP2L and RCAP2H. Timer 2 underflow sets the TF2 flag and causes 0FFFFH to be reloaded into the timer registers TL2 and TH2.

The external flag EXF2 toggles when Timer 2 underflows or overflows. This EXF2 bit can be used as a 17th bit of resolution if needed. The EXF2 flag does not generate an interrupt in this mode of operation.

| | | (MSB) | | | | | | | (LSB) |
|--------|----------|--|------|------|------|-------|-----|------|--------|
| | | TF2 | EXF2 | RCLK | TCLK | EXEN2 | TR2 | C/T2 | CP/RL2 |
| Symbol | Position | Name and Significance | | | | | | | |
| TF2 | T2CON.7 | Timer 2 overflow flag set by a Timer 2 overflow and must be cleared by software. TF2 will not be set when either RCLK or TCLK = 1. | | | | | | | |
| EXF2 | T2CON.6 | Timer 2 external flag set when either a capture or reload is caused by a negative transition on T2EX and EXEN2 = 1. When Timer 2 interrupt is enabled, EXF2 = 1 will cause the CPU to vector to the Timer 2 interrupt routine. EXF2 must be cleared by software. EXF2 does not cause an interrupt in up/down counter mode (DCEN = 1). | | | | | | | |
| RCLK | T2CON.5 | Receive clock flag. When set, causes the serial port to use Timer 2 overflow pulses for its receive clock in modes 1 and 3. RCLK = 0 causes Timer 1 overflow to be used for the receive clock. | | | | | | | |
| TCLK | T2CON.4 | Transmit clock flag. When set, causes the serial port to use Timer 2 overflow pulses for its transmit clock in modes 1 and 3. TCLK = 0 causes Timer 1 overflows to be used for the transmit clock. | | | | | | | |
| EXEN2 | T2CON.3 | Timer 2 external enable flag. When set, allows a capture or reload to occur as a result of a negative transition on T2EX if Timer 2 is not being used to clock the serial port. EXEN2 = 0 causes Timer 2 to ignore events at T2EX. | | | | | | | |
| TR2 | T2CON.2 | Start/stop control for Timer 2. A logic 1 starts the timer. | | | | | | | |
| C/T2 | T2CON.1 | Timer or counter select. (Timer 2) 0 = Internal timer (OSC/6 in 6-clock mode or OSC/12 in 12-clock mode) 1 = External event counter (falling edge triggered). | | | | | | | |
| CP/RL2 | T2CON.0 | Capture/Reload flag. When set, captures will occur on negative transitions at T2EX if EXEN2 = 1. When cleared, auto-reloads will occur either with Timer 2 overflows or negative transitions at T2EX when EXEN2 = 1. When either RCLK = 1 or TCLK = 1, this bit is ignored and the timer is forced to auto-reload on Timer 2 overflow. | | | | | | | |

SU01251

Figure 1. Timer/Counter 2 (T2CON) Control Register

80C51 8-bit microcontroller family 16 KB OTP/ROM, 512B RAM, low voltage (2.7 to 5.5 V), low power, high speed (30/33 MHz), two 400KB I²C interfaces

P8xC660X2/661X2

Table 3. Timer 2 Operating Modes

| RCLK + TCLK | CP/RL2 | TR2 | MODE |
|-------------|--------|-----|---------------------|
| 0 | 0 | 1 | 16-bit Auto-reload |
| 0 | 1 | 1 | 16-bit Capture |
| 1 | X | 1 | Baud rate generator |
| X | X | 0 | (off) |

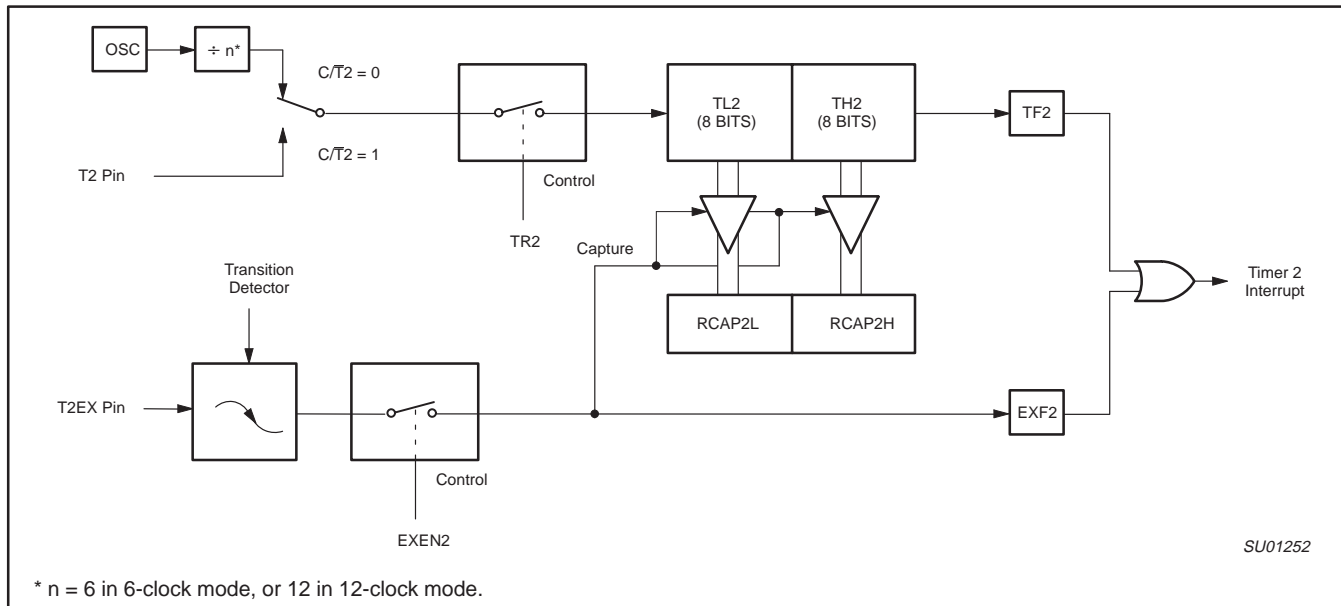

Figure 2. Timer 2 in Capture Mode

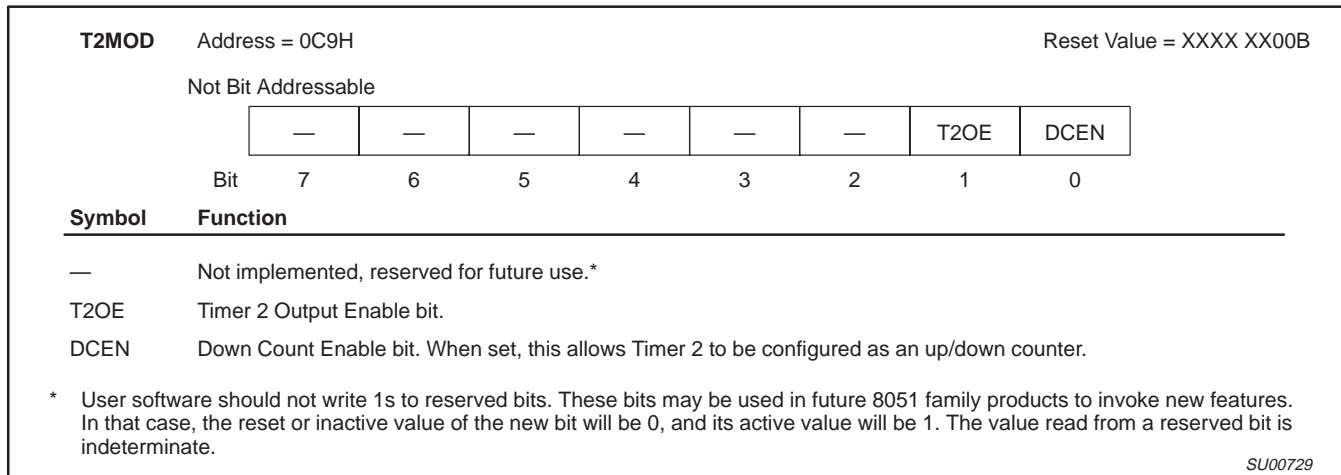

Figure 3. Timer 2 Mode (T2MOD) Control Register

80C51 8-bit microcontroller family 16 KB OTP/ROM, 512B RAM, low voltage (2.7 to 5.5 V), low power, high speed (30/33 MHz), two 400KB I²C interfaces

P8xC660X2/661X2

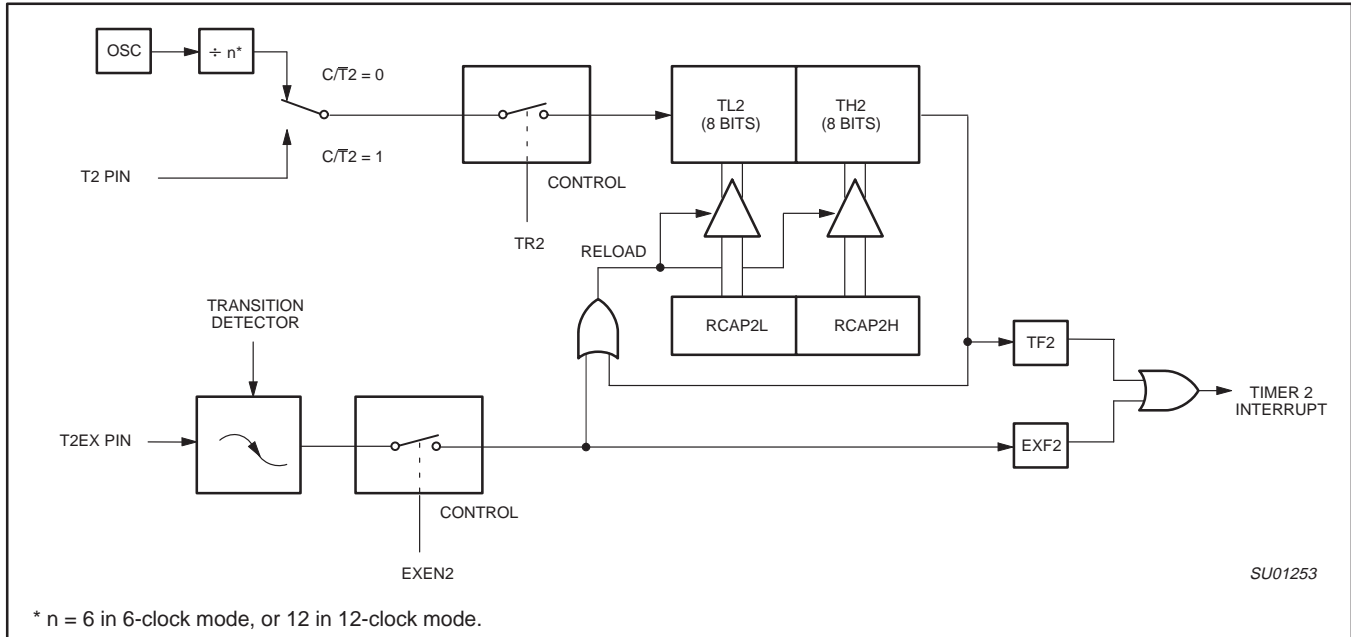

Figure 4. Timer 2 in Auto-Reload Mode (DCEN = 0)

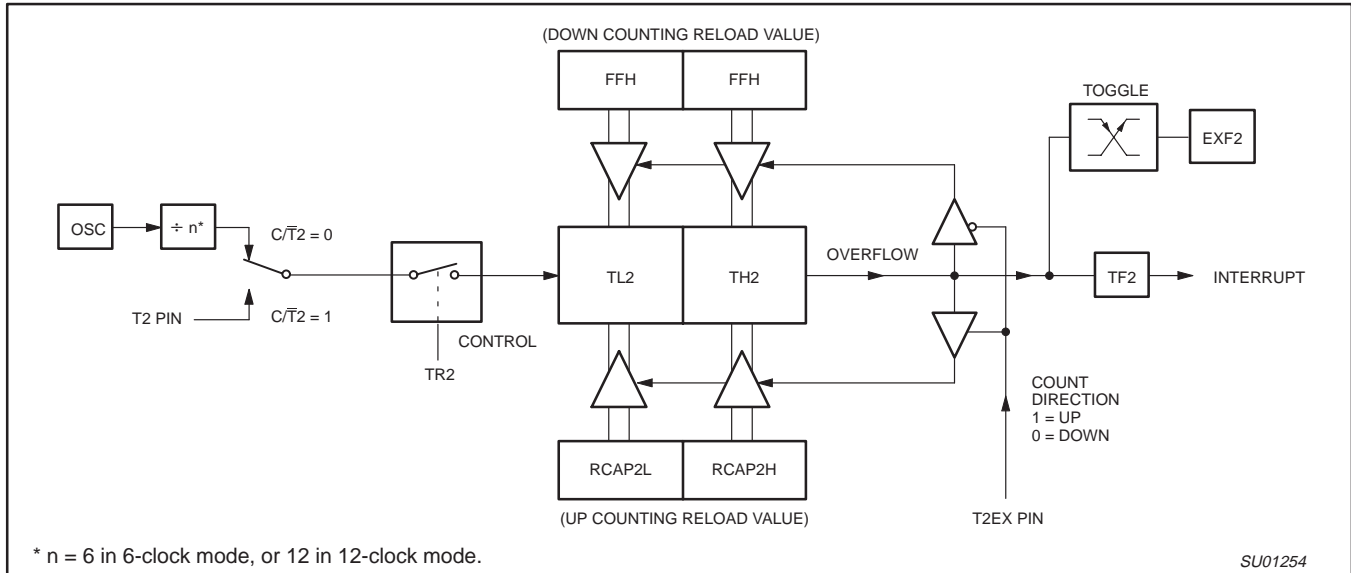

Figure 5. Timer 2 Auto Reload Mode (DCEN = 1)

80C51 8-bit microcontroller family 16 KB OTP/ROM, 512B RAM, low voltage (2.7 to 5.5 V), low power, high speed (30/33 MHz), two 400KB I²C interfaces

P8xC660X2/661X2

When Timer 2 is in the baud rate generator mode, one should not try to read or write TH2 and TL2. As a baud rate generator, Timer 2 is incremented every state time ($osc/2$) or asynchronously from pin T2; under these conditions, a read or write of TH2 or TL2 may not be accurate. The RCAP2 registers may be read, but should not be written to, because a write might overlap a reload and cause write and/or reload errors. The timer should be turned off (clear TR2) before accessing the Timer 2 or RCAP2 registers.

Table 4 shows commonly used baud rates and how they can be obtained from Timer 2.

Summary of Baud Rate Equations

Timer 2 is in baud rate generating mode. If Timer 2 is being clocked through pin T2 (P1.0) the baud rate is:

$$\text{Baud Rate} = \frac{\text{Timer 2 Overflow Rate}}{16}$$

If Timer 2 is being clocked internally, the baud rate is:

$$\text{Baud Rate} = \frac{f_{osc}}{[n * \times [65536 - (RCAP2H, RCAP2L)]]}$$

* n = 16 in 6-clock mode
32 in 12-clock mode

Where f_{OSC} = Oscillator Frequency

To obtain the reload value for RCAP2H and RCAP2L, the above equation can be rewritten as:

$$RCAP2H, RCAP2L = 65536 - \left(\frac{f_{osc}}{n * \times \text{Baud Rate}} \right)$$

Timer/Counter 2 Set-up

Except for the baud rate generator mode, the values given for T2CON do not include the setting of the TR2 bit. Therefore, bit TR2 must be set, separately, to turn the timer on. see Table 5 for set-up of Timer 2 as a timer. Also see Table 6 for set-up of Timer 2 as a counter.

Table 5. Timer 2 as a Timer

| MODE | T2CON | |
|---|------------------------------|------------------------------|
| | INTERNAL CONTROL (Note 1) | EXTERNAL CONTROL (Note 2) |
| 16-bit Auto-Reload | 00H | 08H |
| 16-bit Capture | 01H | 09H |
| Baud rate generator receive and transmit same baud rate | 34H | 36H |
| Receive only | 24H | 26H |
| Transmit only | 14H | 16H |

Table 6. Timer 2 as a Counter

| MODE | TMOD | |
|-------------|------------------------------|------------------------------|
| | INTERNAL CONTROL (Note 1) | EXTERNAL CONTROL (Note 2) |
| 16-bit | 02H | 0AH |
| Auto-Reload | 03H | 0BH |

NOTES:

1. Capture/reload occurs only on timer/counter overflow.
2. Capture/reload occurs on timer/counter overflow and a 1-to-0 transition on T2EX (P1.1) pin except when Timer 2 is used in the baud rate generator mode.

80C51 8-bit microcontroller family 16 KB OTP/ROM, 512B RAM, low voltage (2.7 to 5.5 V), low power, high speed (30/33 MHz), two 400KB I²C interfaces

P8xC660X2/661X2

FULL-DUPLEX ENHANCED UART

Standard UART operation

The serial port is full duplex, meaning it can transmit and receive simultaneously. It is also receive-buffered, meaning it can commence reception of a second byte before a previously received byte has been read from the register. (However, if the first byte still hasn't been read by the time reception of the second byte is complete, one of the bytes will be lost.) The serial port receive and transmit registers are both accessed at Special Function Register SBUF. Writing to SBUF loads the transmit register, and reading SBUF accesses a physically separate receive register.

The serial port can operate in 4 modes:

- Mode 0:** Serial data enters and exits through RxD. TxD outputs the shift clock. 8 bits are transmitted/received (LSB first). The baud rate is fixed at 1/12 the oscillator frequency in 12-clock mode or 1/6 the oscillator frequency in 6-clock mode.
- Mode 1:** 10 bits are transmitted (through TxD) or received (through RxD): a start bit (0), 8 data bits (LSB first), and a stop bit (1). On receive, the stop bit goes into RB8 in Special Function Register SCON. The baud rate is variable.
- Mode 2:** 11 bits are transmitted (through TxD) or received (through RxD): start bit (0), 8 data bits (LSB first), a programmable 9th data bit, and a stop bit (1). On Transmit, the 9th data bit (TB8 in SCON) can be assigned the value of 0 or 1. Or, for example, the parity bit (P, in the PSW) could be moved into TB8. On receive, the 9th data bit goes into RB8 in Special Function Register SCON, while the stop bit is ignored. The baud rate is programmable to either 1/32 or 1/64 the oscillator frequency in 12-clock mode or 1/16 or 1/32 the oscillator frequency in 6-clock mode.
- Mode 3:** 11 bits are transmitted (through TxD) or received (through RxD): a start bit (0), 8 data bits (LSB first), a programmable 9th data bit, and a stop bit (1). In fact, Mode 3 is the same as Mode 2 in all respects except baud rate. The baud rate in Mode 3 is variable.

In all four modes, transmission is initiated by any instruction that uses SBUF as a destination register. Reception is initiated in Mode 0 by the condition RI = 0 and REN = 1. Reception is initiated in the other modes by the incoming start bit if REN = 1.

Multiprocessor Communications

Modes 2 and 3 have a special provision for multiprocessor communications. In these modes, 9 data bits are received. The 9th one goes into RB8. Then comes a stop bit. The port can be programmed such that when the stop bit is received, the serial port interrupt will be activated only if RB8 = 1. This feature is enabled by setting bit SM2 in SCON. A way to use this feature in multiprocessor systems is as follows:

When the master processor wants to transmit a block of data to one of several slaves, it first sends out an address byte which identifies the target slave. An address byte differs from a data byte in that the 9th bit is 1 in an address byte and 0 in a data byte. With SM2 = 1, no slave will be interrupted by a data byte. An address byte, however, will interrupt all slaves, so that each slave can examine the received byte and see if it is being addressed. The addressed slave will clear its SM2 bit and prepare to receive the data bytes that will be coming.

The slaves that weren't being addressed leave their SM2s set and go on about their business, ignoring the coming data bytes.

SM2 has no effect in Mode 0, and in Mode 1 can be used to check the validity of the stop bit. In a Mode 1 reception, if SM2 = 1, the receive interrupt will not be activated unless a valid stop bit is received.

Serial Port Control Register

The serial port control and status register is the Special Function Register SCON, shown in Figure 7. This register contains not only the mode selection bits, but also the 9th data bit for transmit and receive (TB8 and RB8), and the serial port interrupt bits (TI and RI).

Baud Rates

The baud rate in Mode 0 is fixed: Mode 0 Baud Rate = Oscillator Frequency / 12 (12-clock mode) or / 6 (6-clock mode). The baud rate in Mode 2 depends on the value of bit SMOD in Special Function Register PCON. If SMOD = 0 (which is the value on reset), and the port pins in 12-clock mode, the baud rate is 1/64 the oscillator frequency. If SMOD = 1, the baud rate is 1/32 the oscillator frequency. In 6-clock mode, the baud rate is 1/32 or 1/16 the oscillator frequency, respectively.

Mode 2 Baud Rate =

$$\frac{2^{SMOD}}{n} \times (\text{Oscillator Frequency})$$

Where:

$$n = 64 \text{ in 12-clock mode, } 32 \text{ in 6-clock mode}$$

The baud rates in Modes 1 and 3 are determined by the Timer 1 or Timer 2 overflow rate.

Using Timer 1 to Generate Baud Rates

When Timer 1 is used as the baud rate generator (T2CON.RCLK = 0, T2CON.TCLK = 0), the baud rates in Modes 1 and 3 are determined by the Timer 1 overflow rate and the value of SMOD as follows:

Mode 1, 3 Baud Rate =

$$\frac{2^{SMOD}}{n} \times (\text{Timer 1 Overflow Rate})$$

Where:

$$n = 32 \text{ in 12-clock mode, } 16 \text{ in 6-clock mode}$$

The Timer 1 interrupt should be disabled in this application. The Timer itself can be configured for either "timer" or "counter" operation, and in any of its 3 running modes. In the most typical applications, it is configured for "timer" operation, in the auto-reload mode (high nibble of TMOD = 0010B). In that case the baud rate is given by the formula:

Mode 1, 3 Baud Rate =

$$\frac{2^{SMOD}}{n} \times \frac{\text{Oscillator Frequency}}{12 \times [256 - (TH1)]}$$

Where:

$$n = 32 \text{ in 12-clock mode, } 16 \text{ in 6-clock mode}$$

One can achieve very low baud rates with Timer 1 by leaving the Timer 1 interrupt enabled, and configuring the Timer to run as a 16-bit timer (high nibble of TMOD = 0001B), and using the Timer 1 interrupt to do a 16-bit software reload. Figure 8 lists various commonly used baud rates and how they can be obtained from Timer 1.

80C51 8-bit microcontroller family 16 KB OTP/ROM, 512B RAM, low voltage (2.7 to 5.5 V), low power, high speed (30/33 MHz), two 400KB I²C interfaces

P8xC660X2/661X2

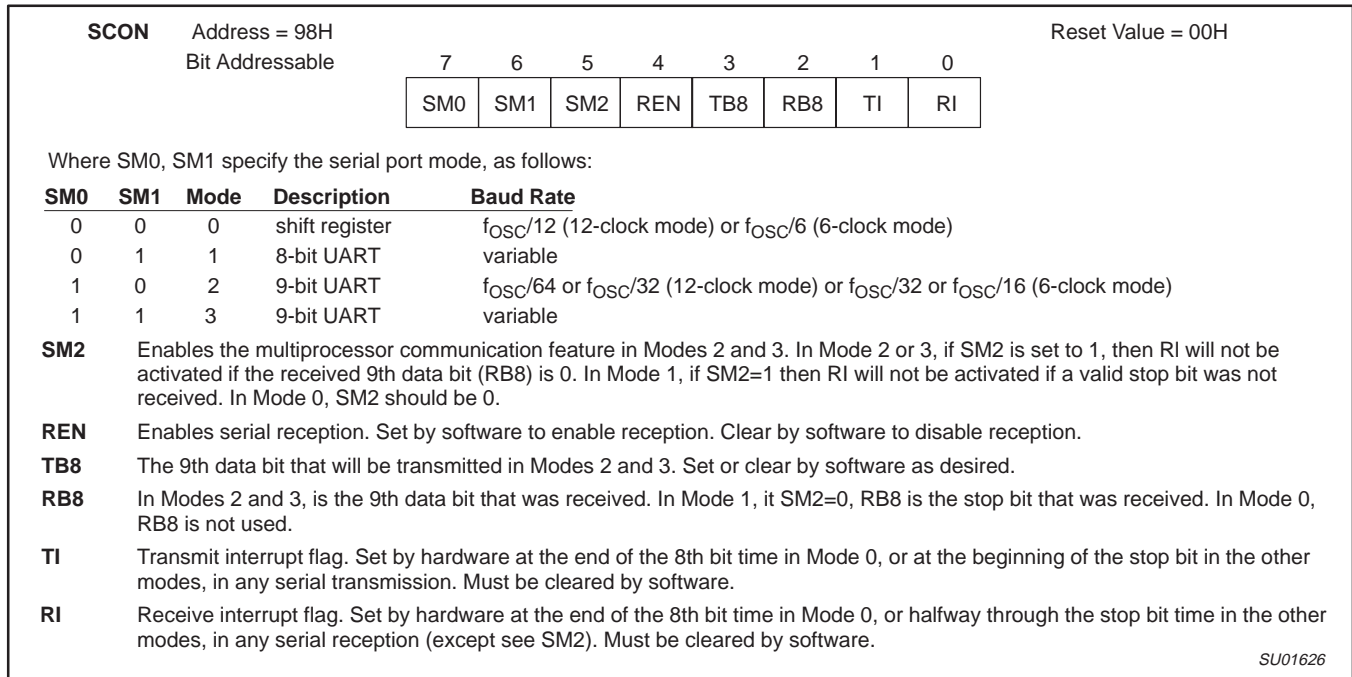

Figure 7. Serial Port Control (SCON) Register

| Baud Rate | | | f _{osc} | SMOD | Timer 1 | | |
|---------------|---------------|--------------|------------------|------|---------|------|--------------|
| Mode | 12-clock mode | 6-clock mode | | | C/T | Mode | Reload Value |
| Mode 0 Max | 1.67 MHz | 3.34 MHz | 20 MHz | X | X | X | X |
| Mode 2 Max | 625 k | 1250 k | 20 MHz | 1 | X | X | X |
| Mode 1, 3 Max | 104.2 k | 208.4 k | 20 MHz | 1 | 0 | 2 | FFH |
| Mode 1, 3 | 19.2 k | 38.4 k | 11.059 MHz | 1 | 0 | 2 | FDH |
| | 9.6 k | 19.2 k | 11.059 MHz | 0 | 0 | 2 | FDH |
| | 4.8 k | 9.6 k | 11.059 MHz | 0 | 0 | 2 | FAH |
| | 2.4 k | 4.8 k | 11.059 MHz | 0 | 0 | 2 | F4H |
| | 1.2 k | 2.4 k | 11.059 MHz | 0 | 0 | 2 | E8H |
| | 137.5 | 275 | 11.986 MHz | 0 | 0 | 2 | 1DH |
| | 110 | 220 | 6 MHz | 0 | 0 | 2 | 72H |
| | 110 | 220 | 12 MHz | 0 | 0 | 1 | FEEBH |

Figure 8. Timer 1 Generated Commonly Used Baud Rates

More About Mode 0

Serial data enters and exits through Rx/D. Tx/D outputs the shift clock. 8 bits are transmitted/received: 8 data bits (LSB first). The baud rate is fixed a 1/12 the oscillator frequency (12-clock mode) or 1/6 the oscillator frequency (6-clock mode).

Figure 9 shows a simplified functional diagram of the serial port in Mode 0, and associated timing.

Transmission is initiated by any instruction that uses SBUF as a destination register. The "write to SBUF" signal at S6P2 also loads a 1 into the 9th position of the transmit shift register and tells the TX Control block to commence a transmission. The internal timing is such that one full machine cycle will elapse between "write to SBUF" and activation of SEND.

SEND enables the output of the shift register to the alternate output function line of P3.0 and also enable SHIFT CLOCK to the alternate output function line of P3.1. SHIFT CLOCK is LOW during S3, S4, and S5 of every machine cycle, and HIGH during S6, S1, and S2. At

S6P2 of every machine cycle in which SEND is active, the contents of the transmit shift are shifted to the right one position.

As data bits shift out to the right, zeros come in from the left. When the MSB of the data byte is at the output position of the shift register, then the 1 that was initially loaded into the 9th position, is just to the left of the MSB, and all positions to the left of that contain zeros. This condition flags the TX Control block to do one last shift and then deactivate SEND and set T1. Both of these actions occur at S1P1 of the 10th machine cycle after "write to SBUF."

Reception is initiated by the condition REN = 1 and R1 = 0. At S6P2 of the next machine cycle, the RX Control unit writes the bits 11111110 to the receive shift register, and in the next clock phase activates RECEIVE.

RECEIVE enable SHIFT CLOCK to the alternate output function line of P3.1. SHIFT CLOCK makes transitions at S3P1 and S6P1 of every machine cycle. At S6P2 of every machine cycle in which RECEIVE is active, the contents of the receive shift register are

80C51 8-bit microcontroller family 16 KB OTP/ROM, 512B RAM, low voltage (2.7 to 5.5 V), low power, high speed (30/33 MHz), two 400KB I²C interfaces

P8xC660X2/661X2

shifted to the left one position. The value that comes in from the right is the value that was sampled at the P3.0 pin at S5P2 of the same machine cycle.

As data bits come in from the right, 1s shift out to the left. When the 0 that was initially loaded into the rightmost position arrives at the leftmost position in the shift register, it flags the RX Control block to do one last shift and load SBUF. At S1P1 of the 10th machine cycle after the write to SCON that cleared RI, RECEIVE is cleared as RI is set.

More About Mode 1

Ten bits are transmitted (through TxD), or received (through RxD): a start bit (0), 8 data bits (LSB first), and a stop bit (1). On receive, the stop bit goes into RB8 in SCON. In the 80C51 the baud rate is determined by the Timer 1 or Timer 2 overflow rate.

Figure 10 shows a simplified functional diagram of the serial port in Mode 1, and associated timings for transmit receive.

Transmission is initiated by any instruction that uses SBUF as a destination register. The "write to SBUF" signal also loads a 1 into the 9th bit position of the transmit shift register and flags the TX Control unit that a transmission is requested. Transmission actually commences at S1P1 of the machine cycle following the next rollover in the divide-by-16 counter. (Thus, the bit times are synchronized to the divide-by-16 counter, not to the "write to SBUF" signal.)

The transmission begins with activation of SEND which puts the start bit at TxD. One bit time later, DATA is activated, which enables the output bit of the transmit shift register to TxD. The first shift pulse occurs one bit time after that.

As data bits shift out to the right, zeros are clocked in from the left. When the MSB of the data byte is at the output position of the shift register, then the 1 that was initially loaded into the 9th position is just to the left of the MSB, and all positions to the left of that contain zeros. This condition flags the TX Control unit to do one last shift and then deactivate SEND and set TI. This occurs at the 10th divide-by-16 rollover after "write to SBUF."

Reception is initiated by a detected 1-to-0 transition at RxD. For this purpose RxD is sampled at a rate of 16 times whatever baud rate has been established. When a transition is detected, the divide-by-16 counter is immediately reset, and 1FFH is written into the input shift register. Resetting the divide-by-16 counter aligns its rollovers with the boundaries of the incoming bit times.

The 16 states of the counter divide each bit time into 16ths. At the 7th, 8th, and 9th counter states of each bit time, the bit detector samples the value of RxD. The value accepted is the value that was seen in at least 2 of the 3 samples. This is done for noise rejection. If the value accepted during the first bit time is not 0, the receive circuits are reset and the unit goes back to looking for another 1-to-0 transition. This is to provide rejection of false start bits. If the start bit proves valid, it is shifted into the input shift register, and reception of the rest of the frame will proceed.

As data bits come in from the right, 1s shift out to the left. When the start bit arrives at the leftmost position in the shift register (which in mode 1 is a 9-bit register), it flags the RX Control block to do one last shift, load SBUF and RB8, and set RI. The signal to load SBUF and RB8, and to set RI, will be generated if, and only if, the following conditions are met at the time the final shift pulse is generated.:

1. RI = 0, and
2. Either SM2 = 0, or the received stop bit = 1.

If either of these two conditions is not met, the received frame is irretrievably lost. If both conditions are met, the stop bit goes into RB8, the 8 data bits go into SBUF, and RI is activated. At this time,

whether the above conditions are met or not, the unit goes back to looking for a 1-to-0 transition in RxD.

More About Modes 2 and 3

Eleven bits are transmitted (through TxD), or received (through RxD): a start bit (0), 8 data bits (LSB first), a programmable 9th data bit, and a stop bit (1). On transmit, the 9th data bit (TB8) can be assigned the value of 0 or 1. On receive, the 9th data bit goes into RB8 in SCON. The baud rate is programmable to either 1/32 or 1/64 (12-clock mode) or 1/16 or 1/32 the oscillator frequency (6-clock mode) the oscillator frequency in Mode 2. Mode 3 may have a variable baud rate generated from Timer 1 or Timer 2.

Figures 11 and 12 show a functional diagram of the serial port in Modes 2 and 3. The receive portion is exactly the same as in Mode 1. The transmit portion differs from Mode 1 only in the 9th bit of the transmit shift register.

Transmission is initiated by any instruction that uses SBUF as a destination register. The "write to SBUF" signal also loads TB8 into the 9th bit position of the transmit shift register and flags the TX Control unit that a transmission is requested. Transmission commences at S1P1 of the machine cycle following the next rollover in the divide-by-16 counter. (Thus, the bit times are synchronized to the divide-by-16 counter, not to the "write to SBUF" signal.)

The transmission begins with activation of SEND, which puts the start bit at TxD. One bit time later, DATA is activated, which enables the output bit of the transmit shift register to TxD. The first shift pulse occurs one bit time after that. The first shift clocks a 1 (the stop bit) into the 9th bit position of the shift register. Thereafter, only zeros are clocked in. Thus, as data bits shift out to the right, zeros are clocked in from the left. When TB8 is at the output position of the shift register, then the stop bit is just to the left of TB8, and all positions to the left of that contain zeros. This condition flags the TX Control unit to do one last shift and then deactivate SEND and set TI. This occurs at the 11th divide-by-16 rollover after "write to SBUF."

Reception is initiated by a detected 1-to-0 transition at RxD. For this purpose RxD is sampled at a rate of 16 times whatever baud rate has been established. When a transition is detected, the divide-by-16 counter is immediately reset, and 1FFH is written to the input shift register.

At the 7th, 8th, and 9th counter states of each bit time, the bit detector samples the value of R-D. The value accepted is the value that was seen in at least 2 of the 3 samples. If the value accepted during the first bit time is not 0, the receive circuits are reset and the unit goes back to looking for another 1-to-0 transition. If the start bit proves valid, it is shifted into the input shift register, and reception of the rest of the frame will proceed.

As data bits come in from the right, 1s shift out to the left. When the start bit arrives at the leftmost position in the shift register (which in Modes 2 and 3 is a 9-bit register), it flags the RX Control block to do one last shift, load SBUF and RB8, and set RI.

The signal to load SBUF and RB8, and to set RI, will be generated if, and only if, the following conditions are met at the time the final shift pulse is generated.

1. RI = 0, and
2. Either SM2 = 0, or the received 9th data bit = 1.

If either of these conditions is not met, the received frame is irretrievably lost, and RI is not set. If both conditions are met, the received 9th data bit goes into RB8, and the first 8 data bits go into SBUF. One bit time later, whether the above conditions were met or not, the unit goes back to looking for a 1-to-0 transition at the RxD input.

80C51 8-bit microcontroller family 16 KB OTP/ROM, 512B RAM, low voltage (2.7 to 5.5 V), low power, high speed (30/33 MHz), two 400KB I²C interfaces

P8xC660X2/661X2

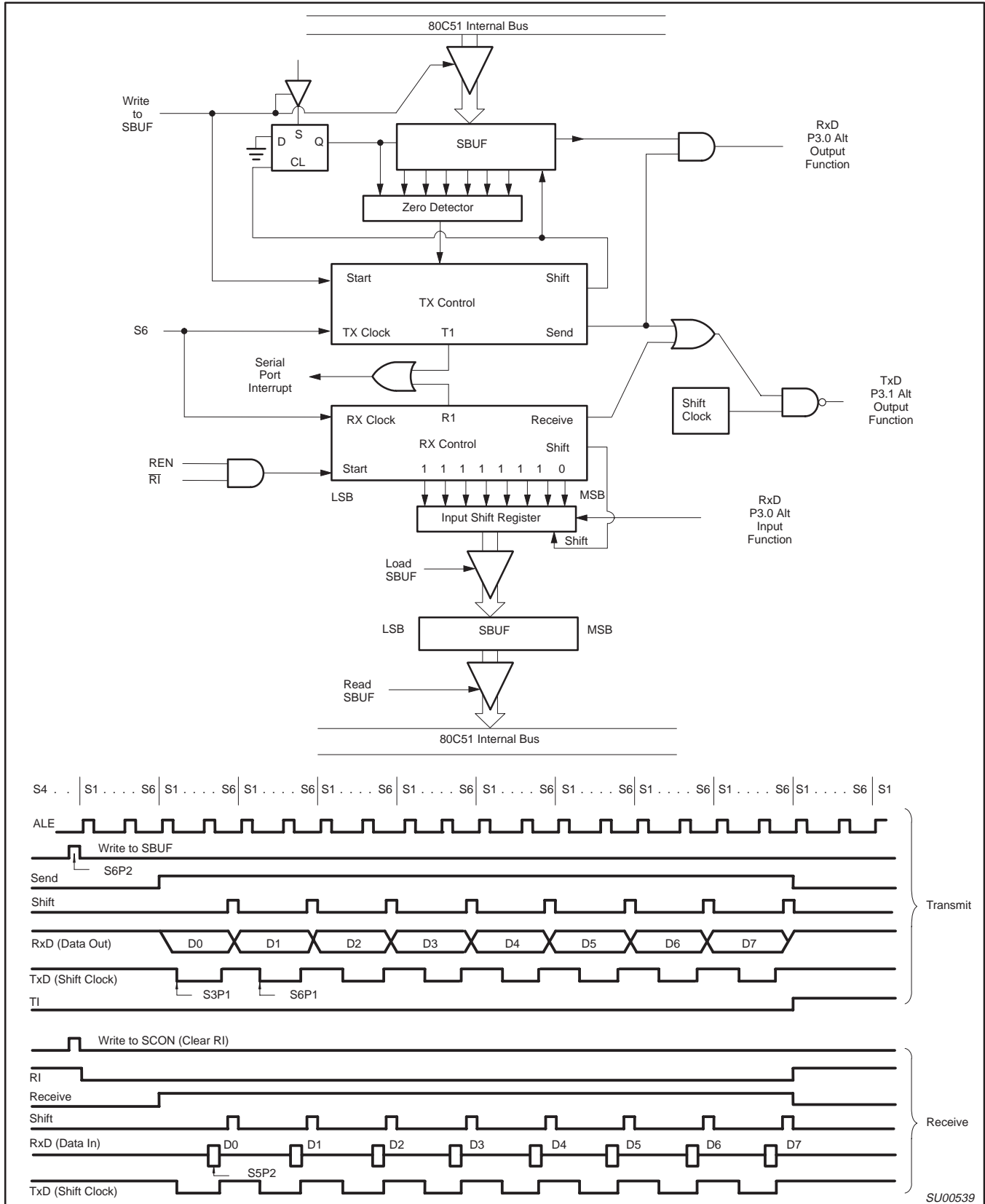
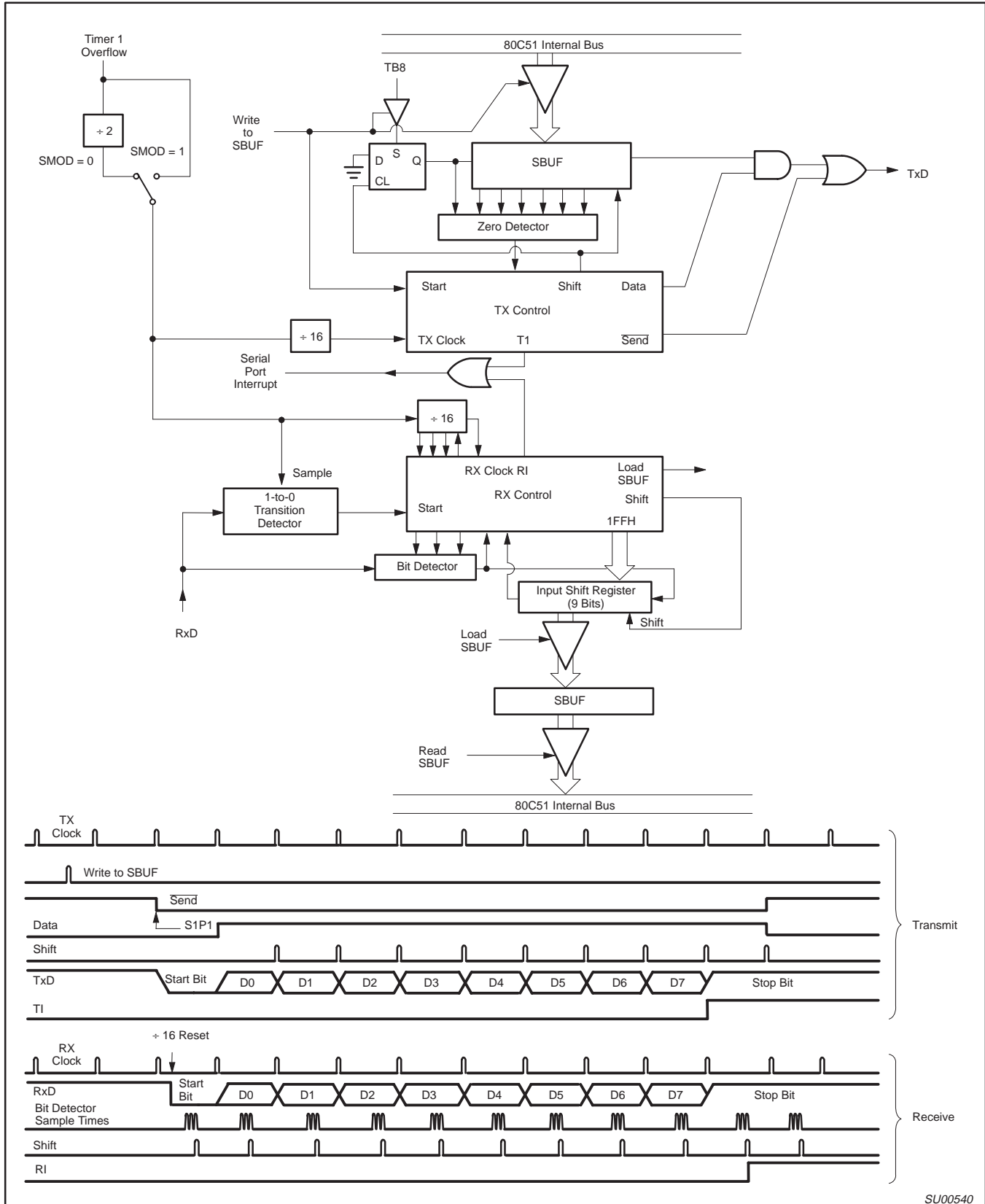

Figure 9. Serial Port Mode 0

SU00539

80C51 8-bit microcontroller family 16 KB OTP/ROM, 512B RAM, low voltage (2.7 to 5.5 V), low power, high speed (30/33 MHz), two 400KB I²C interfaces

P8xC660X2/661X2



SU00540

Figure 10. Serial Port Mode 1

80C51 8-bit microcontroller family 16 KB OTP/ROM, 512B RAM, low voltage (2.7 to 5.5 V), low power, high speed (30/33 MHz), two 400KB I²C interfaces

P8xC660X2/661X2

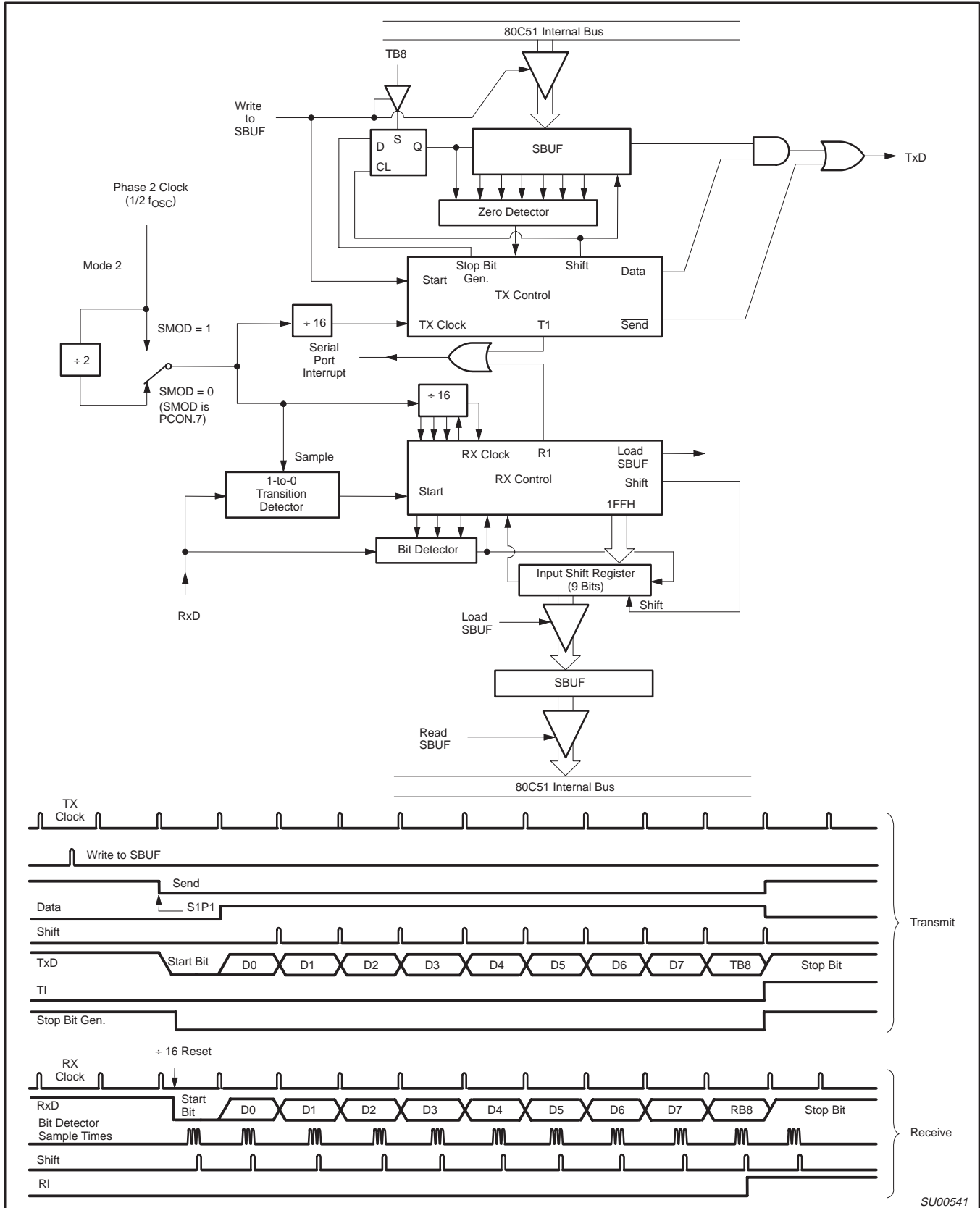

SU00541

Figure 11. Serial Port Mode 2

80C51 8-bit microcontroller family 16 KB OTP/ROM, 512B RAM, low voltage (2.7 to 5.5 V), low power, high speed (30/33 MHz), two 400KB I²C interfaces

P8xC660X2/661X2

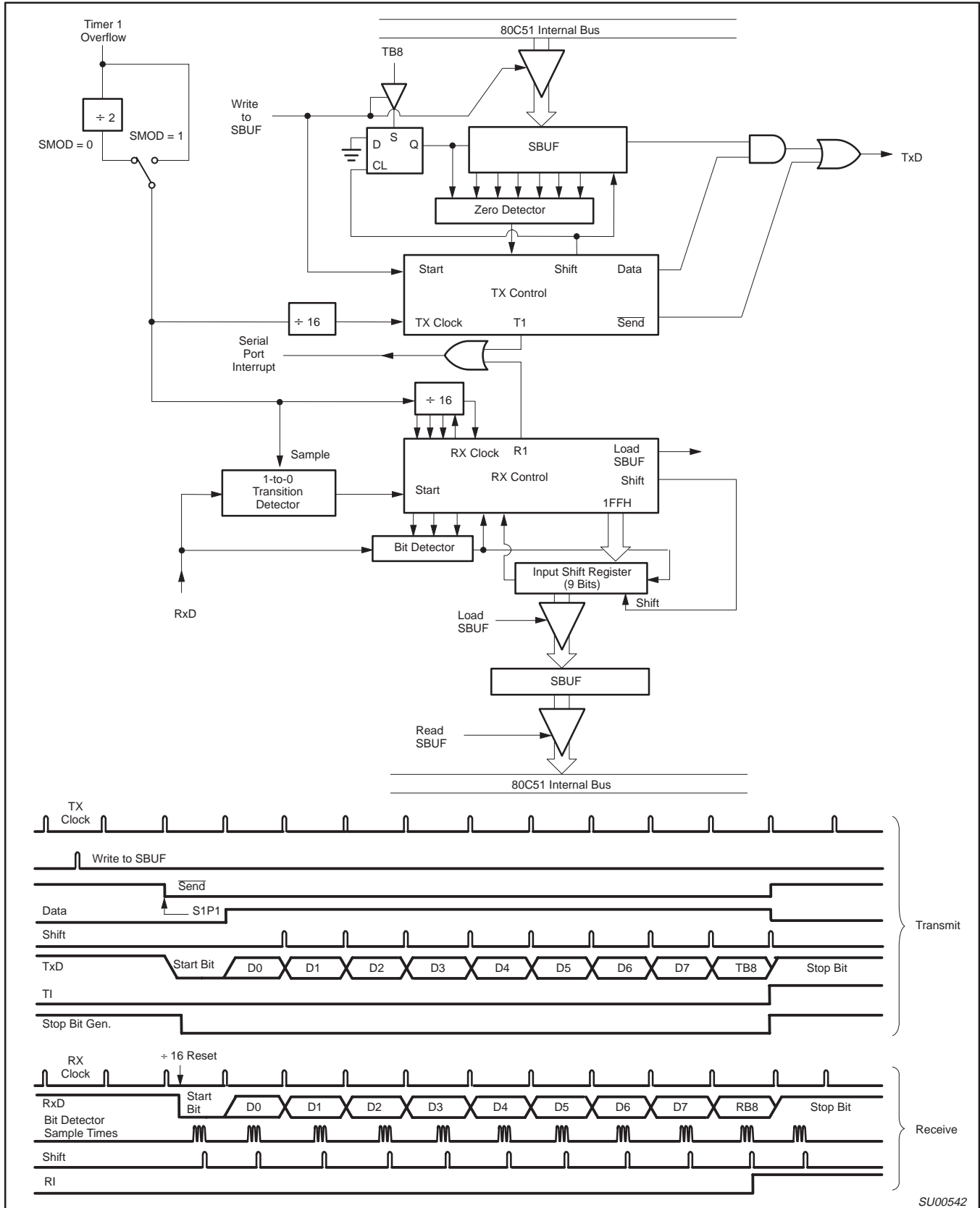

Figure 12. Serial Port Mode 3

80C51 8-bit microcontroller family 16 KB OTP/ROM, 512B RAM, low voltage (2.7 to 5.5 V), low power, high speed (30/33 MHz), two 400KB I²C interfaces

P8xC660X2/661X2

Enhanced Features

The UART operates in all of the usual modes that are described in the first section of *Data Handbook IC20, 80C51-Based 8-Bit Microcontrollers*. In addition the UART can perform framing error detect by looking for missing stop bits, and automatic address recognition. The UART also fully supports multiprocessor communication as does the standard 80C51 UART.

When used for framing error detect the UART looks for missing stop bits in the communication. A missing bit will set the FE bit in the SCON register. The FE bit shares the SCON.7 bit with SM0 and the function of SCON.7 is determined by PCON.6 (SMOD0) (see Figure 7). If SMOD0 is set then SCON.7 functions as FE. SCON.7 functions as SM0 when SMOD0 is cleared. When used as FE SCON.7 can only be cleared by software. Refer to Figure 13.

Automatic Address Recognition

Automatic Address Recognition is a feature which allows the UART to recognize certain addresses in the serial bit stream by using hardware to make the comparisons. This feature saves a great deal of software overhead by eliminating the need for the software to examine every serial address which passes by the serial port. This feature is enabled by setting the SM2 bit in SCON. In the 9 bit UART modes, mode 2 and mode 3, the Receive Interrupt flag (RI) will be automatically set when the received byte contains either the "Given" address or the "Broadcast" address. The 9-bit mode requires that the 9th information bit is a 1 to indicate that the received information is an address and not data. Automatic address recognition is shown in Figure 14.

The 8 bit mode is called Mode 1. In this mode the RI flag will be set if SM2 is enabled and the information received has a valid stop bit following the 8 address bits and the information is either a Given or Broadcast address.

Mode 0 is the Shift Register mode and SM2 is ignored.

Using the Automatic Address Recognition feature allows a master to selectively communicate with one or more slaves by invoking the Given slave address or addresses. All of the slaves may be contacted by using the Broadcast address. Two special Function Registers are used to define the slave's address, SADDR, and the address mask, SADEN. SADEN is used to define which bits in the SADDR are to be used and which bits are "don't care". The SADEN mask can be logically ANDed with the SADDR to create the "Given" address which the master will use for addressing each of the slaves. Use of the Given address allows multiple slaves to be recognized while excluding others. The following examples will help to show the versatility of this scheme:

| | | |
|---------|---------|-----------|
| Slave 0 | SADDR = | 1100 0000 |
| | SADEN = | 1111 1101 |
| | Given = | 1100 00X0 |

| | | |
|---------|---------|-----------|
| Slave 1 | SADDR = | 1100 0000 |
| | SADEN = | 1111 1110 |
| | Given = | 1100 00X0 |

In the above example SADDR is the same and the SADEN data is used to differentiate between the two slaves. Slave 0 requires a 0 in bit 0 and it ignores bit 1. Slave 1 requires a 0 in bit 1 and bit 0 is ignored. A unique address for Slave 0 would be 1100 0010 since slave 1 requires a 0 in bit 1. A unique address for slave 1 would be 1100 0001 since a 1 in bit 0 will exclude slave 0. Both slaves can be selected at the same time by an address which has bit 0 = 0 (for slave 0) and bit 1 = 0 (for slave 1). Thus, both could be addressed with 1100 0000.

In a more complex system the following could be used to select slaves 1 and 2 while excluding slave 0:

| | | |
|---------|---------|-----------|
| Slave 0 | SADDR = | 1100 0000 |
| | SADEN = | 1111 1001 |
| | Given = | 1100 0XX0 |
| Slave 1 | SADDR = | 1110 0000 |
| | SADEN = | 1111 1010 |
| | Given = | 1110 0XX0 |
| Slave 2 | SADDR = | 1110 0000 |
| | SADEN = | 1111 1100 |
| | Given = | 1110 00XX |

In the above example the differentiation among the 3 slaves is in the lower 3 address bits. Slave 0 requires that bit 0 = 0 and it can be uniquely addressed by 1110 0110. Slave 1 requires that bit 1 = 0 and it can be uniquely addressed by 1110 and 0101. Slave 2 requires that bit 2 = 0 and its unique address is 1110 0011. To select Slaves 0 and 1 and exclude Slave 2 use address 1110 0100, since it is necessary to make bit 2 = 1 to exclude slave 2.

The Broadcast Address for each slave is created by taking the logical OR of SADDR and SADEN. Zeros in this result are treated as don't-cares. In most cases, interpreting the don't-cares as ones, the broadcast address will be FF hexadecimal.

Upon reset SADDR (SFR address 0A9H) and SADEN (SFR address 0B9H) are loaded with 0s. This produces a given address of all "don't cares" as well as a Broadcast address of all "don't cares". This effectively disables the Automatic Addressing mode and allows the microcontroller to use standard 80C51 type UART drivers which do not make use of this feature.

80C51 8-bit microcontroller family 16 KB OTP/ROM, 512B RAM, low voltage (2.7 to 5.5 V), low power, high speed (30/33 MHz), two 400KB I²C interfaces

P8xC660X2/661X2

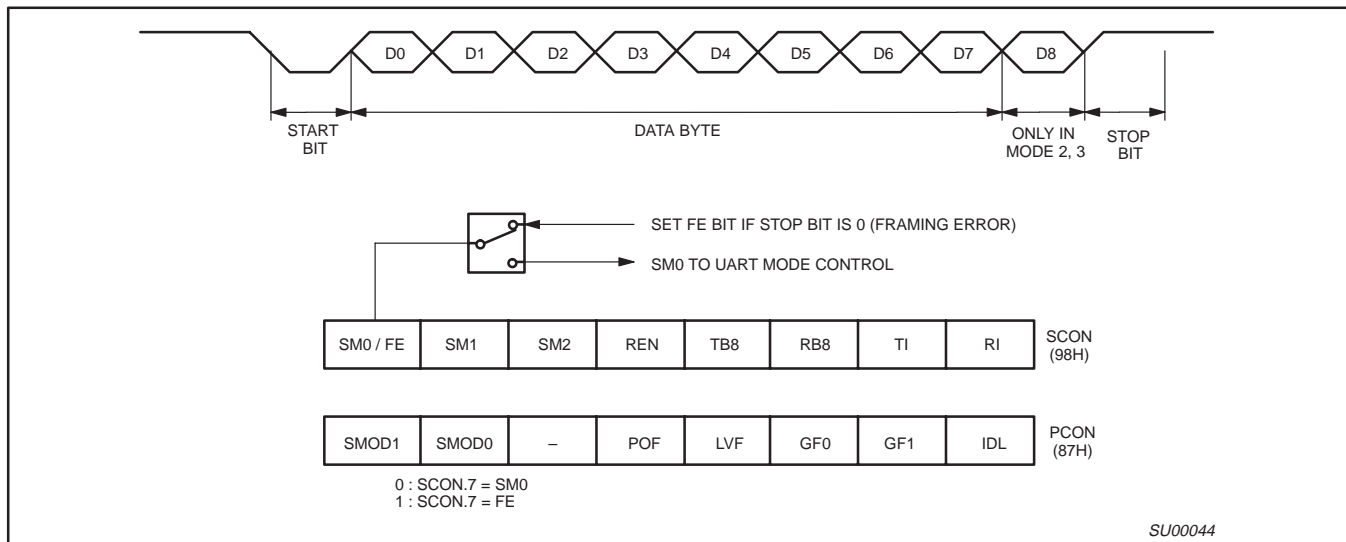

Figure 13. UART Framing Error Detection

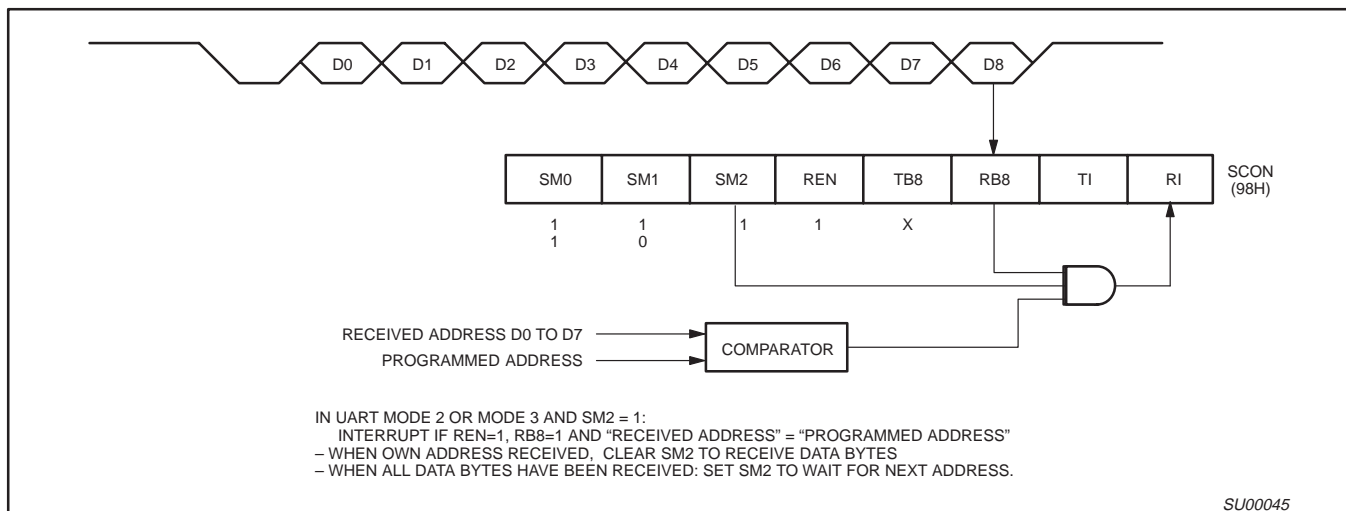

Figure 14. UART Multiprocessor Communication, Automatic Address Recognition

80C51 8-bit microcontroller family 16 KB OTP/ROM, 512B RAM, low voltage (2.7 to 5.5 V), low power, high speed (30/33 MHz), two 400KB I²C interfaces

P8xC660X2/661X2

SIO1 and SIO2, I²C Serial I/O

The I²C-bus is a simple bi-directional 2-wire bus to transfer information between devices connected to the bus. The main features of the bus are:

- Only two bus lines are required: a serial clock line (SCL) and a serial data line (SDA).
- Bi-directional data transfer between masters and slaves.
- Each device connected to the bus is software addressable by a unique address.
- Masters can operate as Master-transmitter or as Master-receiver.
- It is a true multi-master bus (no central master) and includes collision detection and arbitration to prevent data corruption if two or more masters simultaneously initiate data transfer.
- Serial clock synchronization allows devices with different bit rates to communicate via the same serial bus.
- Serial clock synchronization can be used as a handshake mechanism to suspend and resume serial transfer.
- Devices can be added to or removed from an I²C-bus system without affecting any other device on the bus.
- Fault diagnostics and debugging are simple; malfunctions can be immediately traced.

For more information see the Philips publication "The I²C-Bus Specification", especially for detailed descriptions of the Fast and the Standard data-transfer modes. Also, refer to the data sheets for the 8xC552, the 8xC554, the 8xC557, and the 8xC65x.

The SIO1 I²C serial port interface has a selectable bi-directional data-transfer mode, either the 400Kbit/s Fast-mode or the 100Kbit/s Standard-mode. In the Fast-mode, the port performance and the register definitions are identical to those of the 8xC557 devices, and in the Standard-mode (the reset default), they are identical to those of the 8xC652, 8xC654, 8xC552, and 8xC554 devices.

The Fast-mode is functionally the same as the Standard-mode except for the bit rate selection (see Tables 7 and 8), the timing of the SCL and SDA signals (see the I²C electrical characteristics), and the output slew-rate control. The Fast-mode allows up to a four-fold bit-rate increase over that of the Standard-mode, and yet, it is downward compatible with the Standard-mode, i.e. it can be used in a 0 to 100Kbit/s bus system.

The SCL serial port for the clock line of the I²C bus is an alternate function of the P1.6 port pin, and the SDA serial port for the data line of the I²C bus is an alternate function of the P1.7 port pin. Consequently, these 2 port pins are open drain outputs (no pull-ups), and the output latches of P1.6 and P1.7 must be set to logic 1 in order to enable the SIO1 outputs.

The second I²C serial port of the 8xC661X2, SIO2, has the 400Kbit/s Fast data-transfer mode only and selectable slew-rate control of the output pins. It also has the same port performance and register definitions as those of the 8xC557. The SCL1 and SDA1 serial ports have dedicated pins with open-drain outputs and Schmitt-trigger inputs.

There is an analog circuit for controlling the turn-on and turn-off rates of the output pull-down (slew-rate control circuit) which is required to meet the electrical specifications of the Fast-mode under nominal conditions (5 V). To achieve the maximum slew-rates, the

circuit must be disabled. For the SIO1 serial port, the slew-rate control circuits for both the SCL and SDA pins are disabled in the Standard mode (maximum slew-rate), and they are enabled in the Fast-mode. For the SIO2 serial port, the slew-rate control circuits for both pins are enabled by reset, but the Slew-Rate Disable bit (SRD bit) in the AUXR Register disables the slew-rate circuits for both the SCL1 and SDA1 pins when set for maximum slew-rates. This feature of the SIO2 slew-rate control is very useful for higher bus loads, higher temperatures and lower voltages that cause additional decreases in slew-rates.

All of the functional descriptions discussed below apply to both the SIO1 and the SIO2 I²C serial ports although the text may refer to the SIO1 only. See page 10 for the corresponding SIO2 register addresses.

The I²C on-chip logic performs a byte oriented data transfer, clock generation, address recognition and bus control arbitration, and interfaces to the external I²C-bus via the two port pins SCL and SDA. It meets the I²C-bus specification and supports all transfer modes (other than the low-speed mode) from-and-to the I²C-bus. The logic handles byte transfers autonomously. It also keeps track of serial transfers, and a status register (SxSTA) reflects the status of the SIOx logic and the I²C-bus.

The CPU interfaces to the logic of each of the two I²Cs via the following four Special Function Registers (where x=1,2):

- SxCON: Control register, bit addressable by the CPU.
- SxSTA: Status register whose contents may be used as a vector to service routines.
- SxDAT: Data shift register; the data byte is stable as long as the SI bit = 1 (SxCON.3).
- SxADR: Slave address register; its LSB enables / disables general call address recognition.

A typical I²C-bus configuration is shown in Figure 15, and Figure 16 shows how a data transfer is accomplished on the bus. Depending on the state of the direction bit (R/W), two types of data transfers are possible on the I²C-bus:

1. Data transfer from a master transmitter to a slave receiver. The first byte transmitted by the master is the slave address. Next follows a number of data bytes. The slave returns an acknowledge bit after each received byte.
2. Data transfer from a slave transmitter to a master receiver. The first byte (the slave address) is transmitted by the master. The slave then returns an acknowledge bit. Next follows the data bytes transmitted by the slave to the master. The master returns an acknowledge bit after all received bytes other than the last byte. At the end of the last received byte, a "not acknowledge" is returned.

The master device generates all of the serial clock pulses and the START and STOP conditions. A transfer is ended with a STOP condition or with a repeated START condition. Since a repeated START condition is also the beginning of the next serial transfer, the I²C bus will not be released.

Modes of Operation: The on-chip SIO1 logic may operate in the following four modes:

1. Master Transmitter Mode:

Serial data output through P1.7/SDA while P1.6/SCL outputs the serial clock. The first byte transmitted contains the slave address

80C51 8-bit microcontroller family 16 KB OTP/ROM, 512B RAM, low voltage (2.7 to 5.5 V), low power, high speed (30/33 MHz), two 400KB I²C interfaces

P8xC660X2/661X2

of the receiving device (7 bytes) and the data direction bit. In this case the data direction bit (R/W) will be logic 0, and we say that a "W" is transmitted. Thus the first byte transmitted is SLA+W. Serial data is transmitted 8 bits at a time. After each byte is transmitted, an acknowledge bit is received. START and STOP conditions are output to indicate the beginning and the end of a serial transfer.

2. Master Receiver Mode:

The first byte transmitted contains the slave address of the transmitting device (7 bits) and the data direction bit. In this case, the data direction bit (R/W) will be logic 1, and we say that an "R" is transmitted. Thus the first byte transmitted is SLA+R. Serial data is received via P1.7/SDA while P1.6/SCL outputs the serial clock. Serial data is received 8 bits at a time. After each byte is received an acknowledge bit is transmitted. START and STOP conditions are output to indicate the beginning and end of a serial transfer.

3. Slave Receiver Mode:

Serial data and the serial clock are received through P1.7/SDA and P1.6/SCL. After each byte is received, an acknowledge bit is

transmitted. START and STOP conditions are recognized as the beginning and end of a serial transfer. Address recognition is performed by hardware after reception of the slave address and direction bit.

4. Slave Transmitter Mode:

The first byte is received and handled as in the slave receiver mode. However, in this mode, the direction bit will indicate that the transfer direction is reversed. Serial data is transmitted via P1.7/SDA while the serial clock is input through P1.6/SCL. START and STOP conditions are recognized as the beginning and end of a serial transfer.

In a given application, SIO1 may operate as a master and as a slave. In the slave mode, the SIO1 hardware looks for its own slave address and the general call address. If one of these addresses is detected, an interrupt is requested. When the microcontroller wishes to become the bus master, the hardware waits until the bus is free before the master mode is entered so that a possible slave action is not interrupted. If bus arbitration is lost in the master mode, SIO1 switches to the slave mode immediately and can detect its own slave address in the same serial transfer.

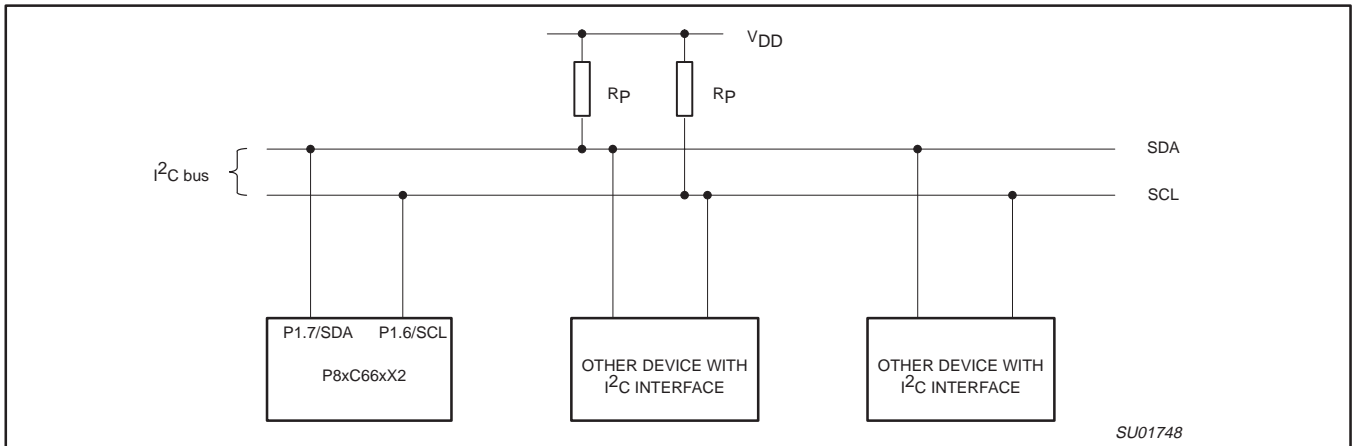

Figure 15. Typical I²C Bus Configuration

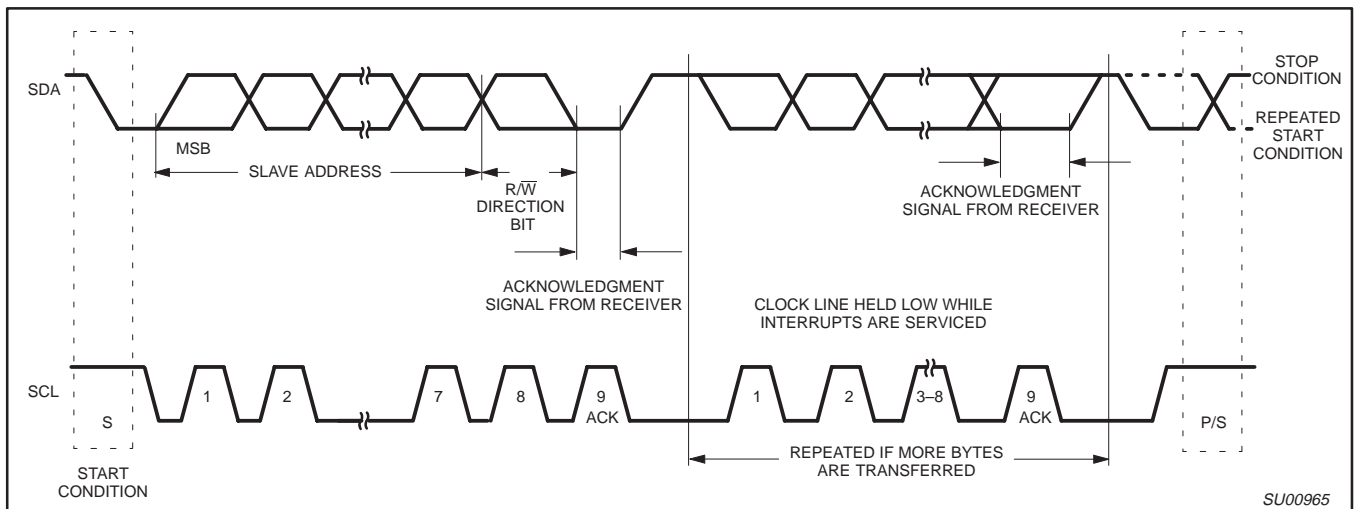

Figure 16. Data Transfer on the I²C Bus

80C51 8-bit microcontroller family 16 KB OTP/ROM, 512B RAM, low voltage (2.7 to 5.5 V), low power, high speed (30/33 MHz), two 400KB I²C interfaces

P8xC660X2/661X2

SIO1 Implementation and Operation: Figure 17 shows how the on-chip I²C bus interface is implemented, and the following text describes the individual blocks.

INPUT FILTERS AND OUTPUT STAGES

The input filters have I²C compatible input levels. If the input voltage is less than 1.5 V, the input logic level is interpreted as 0; if the input voltage is greater than 3.0 V, the input logic level is interpreted as 1. Input signals are synchronized with the internal clock ($f_{OSC}/4$), and spikes shorter than three oscillator periods are filtered out.

The output stages consist of open drain transistors that can sink 3 mA at $V_{OUT} < 0.4$ V. These open drain outputs do not have clamping diodes to V_{DD} . Thus, if the device is connected to the I²C bus and V_{DD} is switched off, the I²C bus is not affected.

ADDRESS REGISTER, S1ADR

This 8-bit special function register may be loaded with the 7-bit slave address (7 most significant bits) to which SIO1 will respond when programmed as a slave transmitter or receiver. The LSB (GC) is used to enable general call address (00H) recognition.

COMPARATOR

The comparator compares the received 7-bit slave address with its own slave address (7 most significant bits in S1ADR). It also compares the first received 8-bit byte with the general call address (00H). If an equality is found, the appropriate status bits are set and an interrupt is requested.

SHIFT REGISTER, S1DAT

This 8-bit special function register contains a byte of serial data to be transmitted or a byte which has just been received. Data in S1DAT is always shifted from right to left; the first bit to be transmitted is the MSB (bit 7) and, after a byte has been received, the first bit of received data is located at the MSB of S1DAT. While data is being shifted out, data on the bus is simultaneously being shifted in; S1DAT always contains the last byte present on the bus. Thus, in the event of lost arbitration, the transition from master transmitter to slave receiver is made with the correct data in S1DAT.

80C51 8-bit microcontroller family 16 KB OTP/ROM, 512B RAM, low voltage (2.7 to 5.5 V), low power, high speed (30/33 MHz), two 400KB I²C interfaces

P8xC660X2/661X2

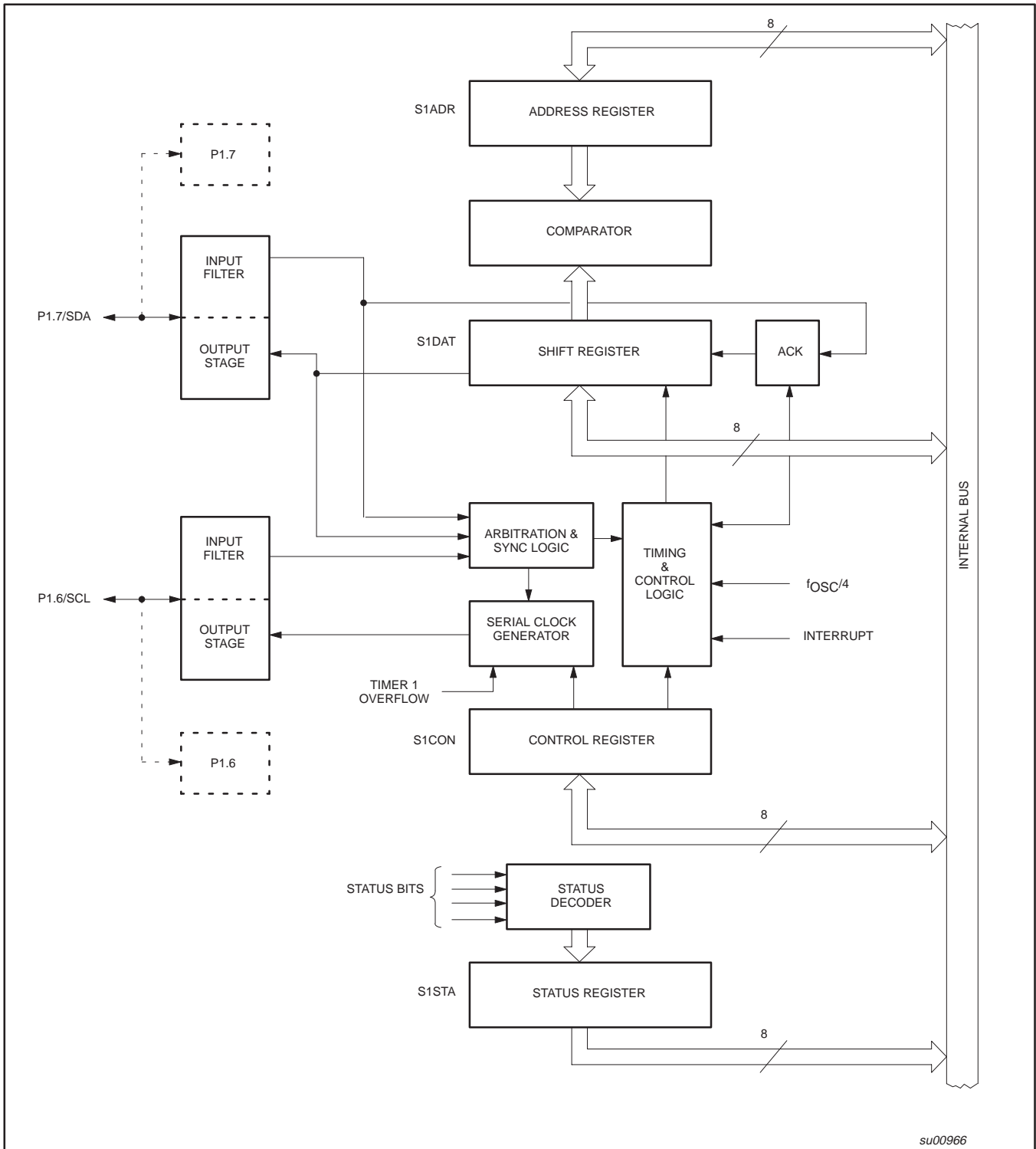

Figure 17. I²C Bus Serial Interface Block Diagram

80C51 8-bit microcontroller family 16 KB OTP/ROM, 512B RAM, low voltage (2.7 to 5.5 V), low power, high speed (30/33 MHz), two 400KB I²C interfaces

P8xC660X2/661X2

ARBITRATION AND SYNCHRONIZATION LOGIC

In the master transmitter mode, the arbitration logic checks that every transmitted logic 1 actually appears as a logic 1 on the I²C bus. If another device on the bus overrules a logic 1 and pulls the SDA line LOW, arbitration is lost, and SIO1 immediately changes from master transmitter to slave receiver. SIO1 will continue to output clock pulses (on SCL) until transmission of the current serial byte is complete.

Arbitration may also be lost in the master receiver mode. Loss of arbitration in this mode can only occur while SIO1 is returning a "not acknowledge: (logic 1) to the bus. Arbitration is lost when another device on the bus pulls this signal LOW. Since this can occur only at the end of a serial byte, SIO1 generates no further clock pulses. Figure 18 shows the arbitration procedure.

The synchronization logic will synchronize the serial clock generator with the clock pulses on the SCL line from another device. If two or more master devices generate clock pulses, the "mark" duration is determined by the device that generates the shortest "marks," and the "space" duration is determined by the device that generates the longest "spaces." Figure 19 shows the synchronization procedure.

A slave may stretch the space duration to slow down the bus master. The space duration may also be stretched for handshaking purposes. This can be done after each bit or after a complete byte transfer. SIO1 will stretch the SCL space duration after a byte has been transmitted or received and the acknowledge bit has been transferred. The serial interrupt flag (SI) is set, and the stretching continues until the serial interrupt flag is cleared.

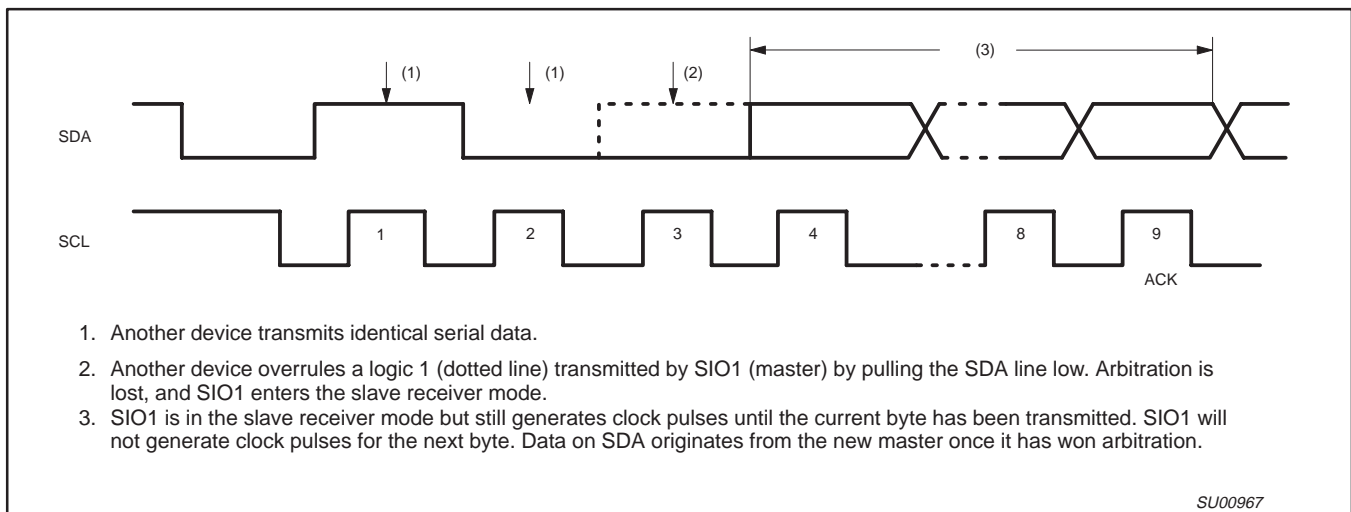

Figure 18. Arbitration Procedure

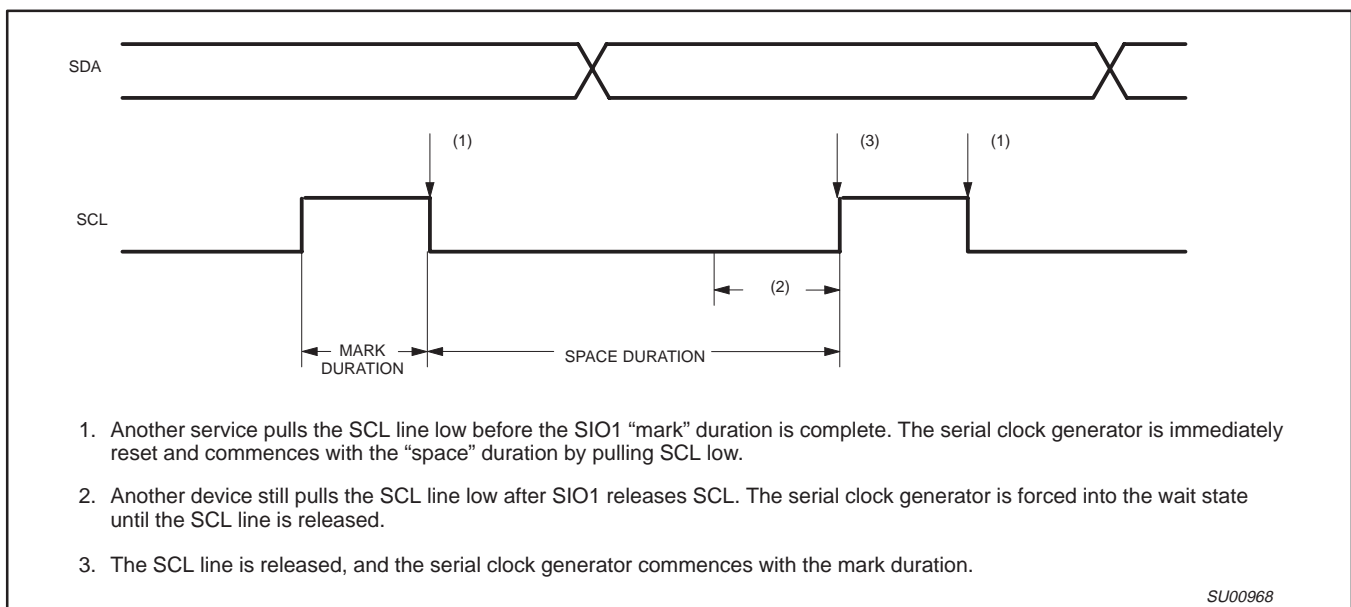

Figure 19. Serial Clock Synchronization

80C51 8-bit microcontroller family 16 KB OTP/ROM, 512B RAM, low voltage (2.7 to 5.5 V), low power, high speed (30/33 MHz), two 400KB I²C interfaces

P8xC660X2/661X2

SERIAL CLOCK GENERATOR

This programmable clock pulse generator provides the SCL clock pulses when SIO1 is in the master transmitter or master receiver mode. It is switched off when SIO1 is in a slave mode. In standard speed mode, the programmable output clock frequencies are: $f_{OSC}/120$, $f_{OSC}/9600$, and the Timer 1 overflow rate divided by eight. The output clock pulses have a 50% duty cycle unless the clock generator is synchronized with other SCL clock sources as described above.

TIMING AND CONTROL

The timing and control logic generates the timing and control signals for serial byte handling. This logic block provides the shift pulses for S1DAT, enables the comparator, generates and detects start and stop conditions, receives and transmits acknowledge bits, controls the master and slave modes, contains interrupt request logic, and monitors the I²C bus status.

CONTROL REGISTER, S1CON

This 7-bit special function register is used by the microcontroller to control the following SIO1 functions: start and restart of a serial transfer, termination of a serial transfer, bit rate, address recognition, and acknowledgment.

STATUS DECODER AND STATUS REGISTER

The status decoder takes all of the internal status bits and compresses them into a 5-bit code. This code is unique for each I²C bus status. The 5-bit code may be used to generate vector addresses for fast processing of the various service routines. Each service routine processes a particular bus status. There are 26 possible bus states if all four modes of SIO1 are used. The 5-bit status code is latched into the five most significant bits of the status register when the serial interrupt flag is set (by hardware) and remains stable until the interrupt flag is cleared by software. The three least significant bits of the status register are always zero. If the status code is used as a vector to service routines, then the routines are displaced by eight address locations. Eight bytes of code is sufficient for most of the service routines (see the software example in this section).

The Four SIO1 Special Function Registers: The microcontroller interfaces to SIO1 via four special function registers. These four SFRs (S1ADR, S1DAT, S1CON, and S1STA) are described individually in the following sections.

The Address Register, S1ADR: The CPU can read from and write to this 8-bit, directly addressable SFR. S1ADR is not affected by the SIO1 hardware. The contents of this register are irrelevant when SIO1 is in a master mode. In the slave modes, the seven most significant bits must be loaded with the microcontroller's own slave address, and, if the least significant bit is set, the general call address (00H) is recognized; otherwise it is ignored.

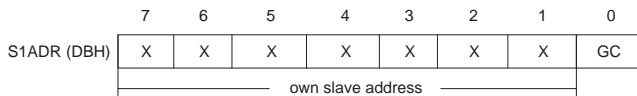

The most significant bit corresponds to the first bit received from the I²C bus after a start condition. A logic 1 in S1ADR corresponds to a HIGH level on the I²C bus, and a logic 0 corresponds to a LOW level on the bus.

The Data Register, S1DAT: S1DAT contains a byte of serial data to be transmitted or a byte which has just been received. The CPU can

read from and write to this 8-bit, directly addressable SFR while it is not in the process of shifting a byte. This occurs when SIO1 is in a defined state and the serial interrupt flag is set. Data in S1DAT remains stable as long as SI is set. Data in S1DAT is always shifted from right to left: the first bit to be transmitted is the MSB (bit 7), and, after a byte has been received, the first bit of received data is located at the MSB of S1DAT. While data is being shifted out, data on the bus is simultaneously being shifted in; S1DAT always contains the last data byte present on the bus. Thus, in the event of lost arbitration, the transition from master transmitter to slave receiver is made with the correct data in S1DAT.

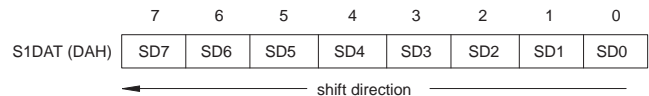

SD7 - SD0:

Eight bits to be transmitted or just received. A logic 1 in S1DAT corresponds to a HIGH level on the I²C bus, and a logic 0 corresponds to a LOW level on the bus. Serial data shifts through S1DAT from right to left. Figure 20 shows how data in S1DAT is serially transferred to and from the SDA line.

S1DAT and the ACK flag form a 9-bit shift register which shifts in or shifts out an 8-bit byte, followed by an acknowledge bit. The ACK flag is controlled by the SIO1 hardware and cannot be accessed by the CPU. Serial data is shifted through the ACK flag into S1DAT on the rising edges of serial clock pulses on the SCL line. When a byte has been shifted into S1DAT, the serial data is available in S1DAT, and the acknowledge bit is returned by the control logic during the ninth clock pulse. Serial data is shifted out from S1DAT via a buffer (BSD7) on the falling edges of clock pulses on the SCL line.

When the CPU writes to S1DAT, BSD7 is loaded with the content of S1DAT.7, which is the first bit to be transmitted to the SDA line (see Figure 21). After nine serial clock pulses, the eight bits in S1DAT will have been transmitted to the SDA line, and the acknowledge bit will be present in ACK. Note that the eight transmitted bits are shifted back into S1DAT.

The Control Register, S1CON: The CPU can read from and write to this 8-bit, directly addressable SFR. Two bits are affected by the SIO1 hardware: the SI bit is set when a serial interrupt is requested, and the STO bit is cleared when a STOP condition is present on the I²C bus. The STO bit is also cleared when ENS1 = "0".



ENS1, THE SIO1 ENABLE BIT

ENS1 = "0": When ENS1 is "0", the SDA and SCL outputs are in a high impedance state. SDA and SCL input signals are ignored, SIO1 is in the "not addressed" slave state, and the STO bit in S1CON is forced to "0". No other bits are affected. P1.6 and P1.7 may be used as open drain I/O ports.

ENS1 = "1": When ENS1 is "1", SIO1 is enabled. The P1.6 and P1.7 port latches must be set to logic 1.

ENS1 should not be used to temporarily release SIO1 from the I²C bus since, when ENS1 is reset, the I²C bus status is lost. The AA flag should be used instead (see description of the AA flag in the following text).

80C51 8-bit microcontroller family 16 KB OTP/ROM, 512B RAM, low voltage (2.7 to 5.5 V), low power, high speed (30/33 MHz), two 400KB I²C interfaces

P8xC660X2/661X2

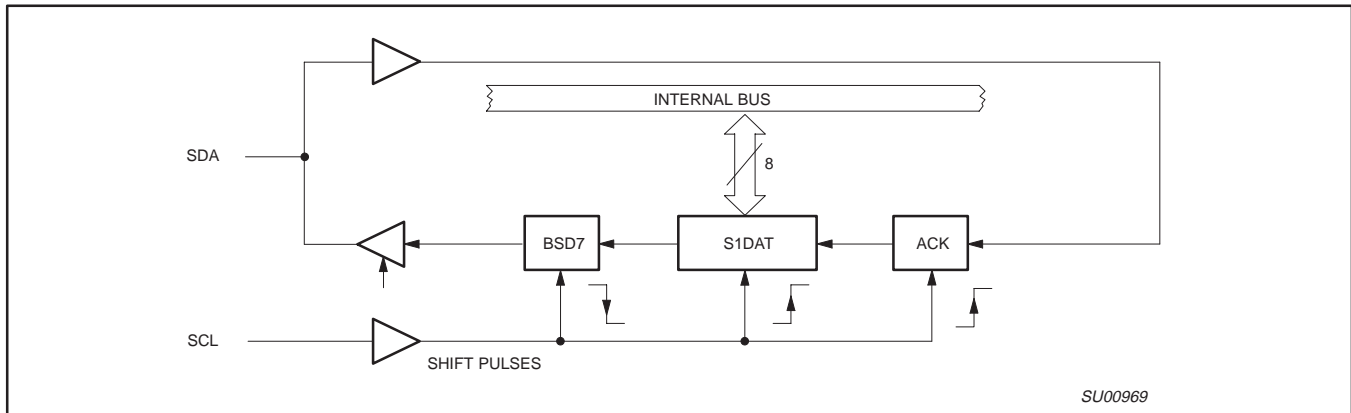

Figure 20. Serial Input/Output Configuration

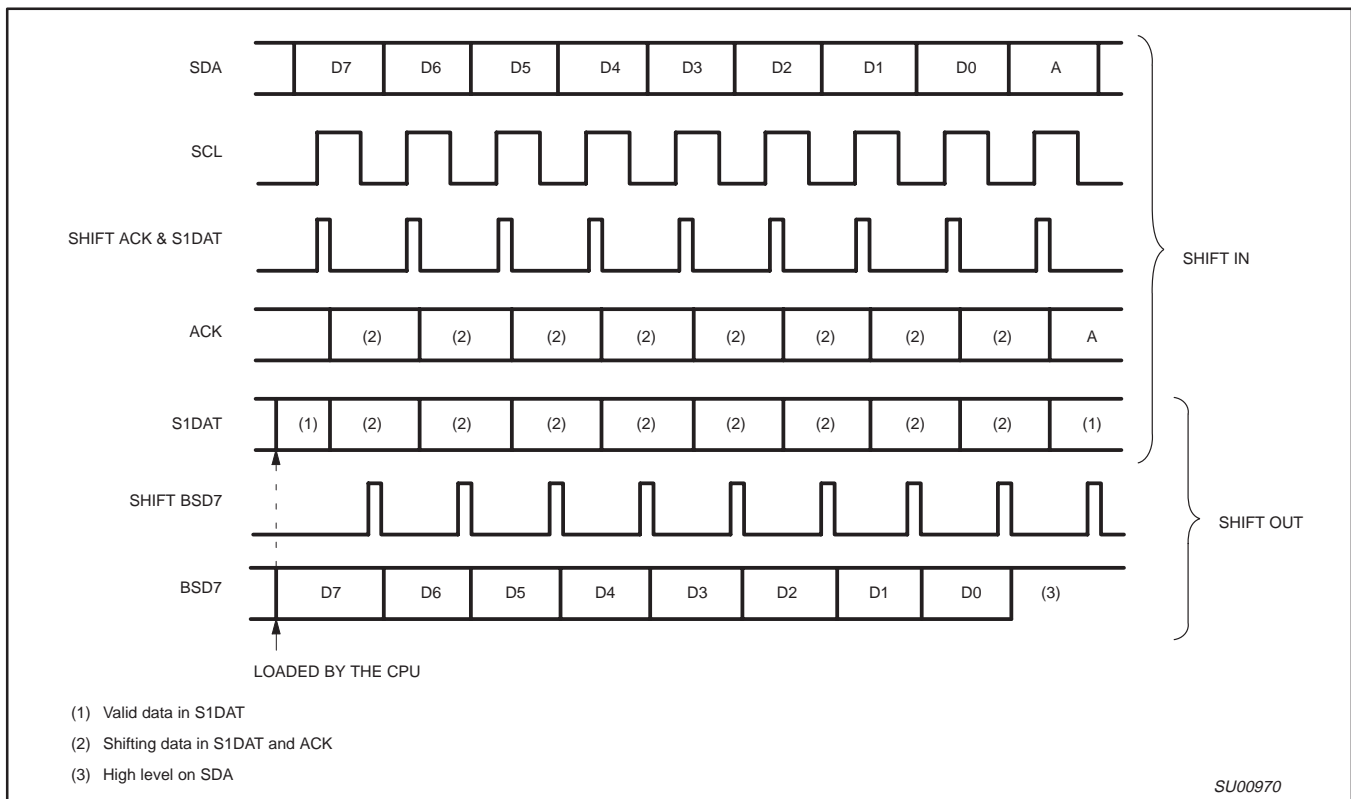

Figure 21. Shift-in and Shift-out Timing

In the following text, it is assumed that ENS1 = "1".

STA, THE START FLAG

STA = "1": When the STA bit is set to enter a master mode, the SIO1 hardware checks the status of the I²C bus and generates a START condition if the bus is free. If the bus is not free, then SIO1 waits for a STOP condition (which will free the bus) and generates a START condition after a delay of a half clock period of the internal serial clock generator.

If STA is set while SIO1 is already in a master mode and one or more bytes are transmitted or received, SIO1 transmits a repeated START condition. STA may be set at any time. STA may also be set when SIO1 is an addressed slave.

STA = "0": When the STA bit is reset, no START condition or repeated START condition will be generated.

STO, THE STOP FLAG

STO = "1": When the STO bit is set while SIO1 is in a master mode, a STOP condition is transmitted to the I²C bus. When the STOP condition is detected on the bus, the SIO1 hardware clears the STO flag. In a slave mode, the STO flag may be set to recover from an error condition. In this case, no STOP condition is transmitted to the I²C bus. However, the SIO1 hardware behaves as if a STOP condition has been received and switches to the defined "not addressed" slave receiver mode. The STO flag is automatically cleared by hardware.

80C51 8-bit microcontroller family 16 KB OTP/ROM, 512B RAM, low voltage (2.7 to 5.5 V), low power, high speed (30/33 MHz), two 400KB I²C interfaces

P8xC660X2/661X2

If the STA and STO bits are both set, the a STOP condition is transmitted to the I²C bus if SIO1 is in a master mode (in a slave mode, SIO1 generates an internal STOP condition which is not transmitted). SIO1 then transmits a START condition.

STO = "0": When the STO bit is reset, no STOP condition will be generated.

SI, THE SERIAL INTERRUPT FLAG

SI = "1": When the SI flag is set, then, if the EA and ES1 (interrupt enable register) bits are also set, a serial interrupt is requested. SI is set by hardware when one of 25 of the 26 possible SIO1 states is entered. The only state that does not cause SI to be set is state F8H, which indicates that no relevant state information is available.

While SI is set, the LOW period of the serial clock on the SCL line is stretched, and the serial transfer is suspended. A HIGH level on the SCL line is unaffected by the serial interrupt flag. SI must be reset by software.

SI = "0": When the SI flag is reset, no serial interrupt is requested, and there is no stretching of the serial clock on the SCL line.

AA, THE ASSERT ACKNOWLEDGE FLAG

AA = "1": If the AA flag is set, an acknowledge (LOW level to SDA) will be returned during the acknowledge clock pulse on the SCL line when:

- The "own slave address" has been received
- The general call address has been received while the general call bit (GC) in S1ADR is set
- A data byte has been received while SIO1 is in the master receiver mode
- A data byte has been received while SIO1 is in the addressed slave receiver mode

AA = "0": if the AA flag is reset, a not acknowledge (HIGH level to SDA) will be returned during the acknowledge clock pulse on SCL when:

- A data has been received while SIO1 is in the master receiver mode
- A data byte has been received while SIO1 is in the addressed slave receiver mode

When SIO1 is in the addressed slave transmitter mode, state C8H will be entered after the last serial is transmitted (see Figure 25). When SI is cleared, SIO1 leaves state C8H, enters the not addressed slave receiver mode, and the SDA line remains at a HIGH level. In state C8H, the AA flag can be set again for future address recognition.

When SIO1 is in the not addressed slave mode, its own slave address and the general call address are ignored. Consequently, no acknowledge is returned, and a serial interrupt is not requested. Thus, SIO1 can be temporarily released from the I²C bus while the

bus status is monitored. While SIO1 is released from the bus, START and STOP conditions are detected, and serial data is shifted in. Address recognition can be resumed at any time by setting the AA flag. If the AA flag is set when the part's own slave address or the general call address has been partly received, the address will be recognized at the end of the byte transmission.

CR0, CR1, AND CR2, THE CLOCK RATE BITS

These three bits determine the serial clock frequency when SIO1 is in a master mode. The various serial rates are shown in Table 7.

For the SIO1 serial port, the Standard data transfer mode is the default mode after reset. To change the data transfer mode to the Fast-mode, the Fast Mode Enable bit (FME bit) of the AUXR Register (AUXR.3 bit) must be set. **After setting the FME bit you cannot clear it** (a one-time set bit), and it can only be **cleared with a reset**.

For the SIO2 serial port, the analog circuits for controlling the slew-rates of the output pull-downs may be disabled with the Slew-Rate Disable bit (AUXR.5 bit). For maximum slew rates, setting this bit disables the slew-rate control circuits of the SCL1 and SDA1 pins. This bit is cleared by reset (reset default), and it can be set/cleared by software. This feature of the SIO2 slew-rate control is very useful for higher bus loads, higher temperatures and lower voltages that cause additional decreases in slew-rates.

| | | | | | | | | |
|------------|---|---|-----|---|-----|---|---------|----|
| | 7 | 6 | 5 | 4 | 3 | 2 | 1 | 0 |
| AUXR (8EH) | - | - | SRD | - | FME | - | EX-TRAM | A0 |

A 12.5kHz bit rate may be used by devices that interface to the I²C bus via standard I/O port lines which are software driven and slow. 100kHz is usually the maximum bit rate and can be derived from a 16 MHz, 12 MHz, or a 6 MHz oscillator. A variable bit rate (0.5kHz to 62.5kHz) may also be used if Timer 1 is not required for any other purpose while SIO1 is in a master mode.

The frequencies shown in Table 7 are unimportant when SIO1 is in a slave mode. In the slave modes, SIO1 will automatically synchronize with any clock frequency up to 100kHz.

The Status Register, S1STA: S1STA is an 8-bit read-only special function register. The three least significant bits are always zero. The five most significant bits contain the status code. There are 26 possible status codes. When S1STA contains F8H, no relevant state information is available and no serial interrupt is requested. All other S1STA values correspond to defined SIO1 states. When each of these states is entered, a serial interrupt is requested (SI = "1"). A valid status code is present in S1STA one machine cycle after SI is set by hardware and is still present one machine cycle after SI has been reset by software.

80C51 8-bit microcontroller family 16 KB OTP/ROM, 512B RAM, low voltage (2.7 to 5.5 V), low power, high speed (30/33 MHz), two 400KB I²C interfaces

P8xC660X2/661X2

Table 7. 400 kbytes I²C interface serial clock rates

| CR2 | CR1 | CR0 | BIT FREQUENCY (kHz) AT f _{OSC} in 6X MODE | | | | | | f _{OSC} DIVIDE BY |
|-----|-----|-----|--|-------|--------|--------|--------|--------|----------------------------|
| | | | 3 MHz | 6 MHz | 12 MHz | 16 MHz | 24 MHz | 30 MHz | |
| 1 | 0 | 0 | 25 | 50 | 100 | 133 | 200 | 250 | 120 |
| 1 | 0 | 1 | 2 | 4 | 8 | 10 | 15 | 19 | 1600 |
| 1 | 1 | 0 | 38 | 75 | 150 | 200 | 300 | 375 | 80 |
| 1 | 1 | 1 | 50 | 100 | 200 | 267 | 400 | 500 | 60 |
| 0 | 0 | 0 | 100 | 200 | 400 | 533 | 800 | 1000 | 30 |
| 0 | 0 | 1 | 4 | 8 | 15 | 20 | 30 | 38 | 800 |
| 0 | 1 | 0 | 150 | 300 | 600 | 800 | 1200 | 1500 | 20 |
| 0 | 1 | 1 | 200 | 400 | 800 | 1067 | 1600 | 2000 | 15 |

| CR2 | CR1 | CR0 | BIT FREQUENCY (kHz) AT f _{OSC} in 12X MODE | | | | | | f _{OSC} DIVIDE BY |
|-----|-----|-----|---|-------|--------|--------|--------|--------|----------------------------|
| | | | 3 MHz | 6 MHz | 12 MHz | 16 MHz | 24 MHz | 33 MHz | |
| 1 | 0 | 0 | 13 | 25 | 50 | 67 | 100 | 138 | 240 |
| 1 | 0 | 1 | 1 | 2 | 4 | 5 | 8 | 10 | 3200 |
| 1 | 1 | 0 | 19 | 38 | 75 | 100 | 150 | 206 | 160 |
| 1 | 1 | 1 | 25 | 50 | 100 | 133 | 200 | 275 | 120 |
| 0 | 0 | 0 | 50 | 100 | 200 | 267 | 400 | 550 | 60 |
| 0 | 0 | 1 | 2 | 4 | 8 | 10 | 15 | 21 | 1600 |
| 0 | 1 | 0 | 75 | 150 | 300 | 400 | 600 | 825 | 40 |
| 0 | 1 | 1 | 100 | 200 | 400 | 533 | 800 | 1100 | 30 |

80C51 8-bit microcontroller family 16 KB OTP/ROM, 512B RAM, low voltage (2.7 to 5.5 V), low power, high speed (30/33 MHz), two 400KB I²C interfaces

P8xC660X2/661X2

Table 8. 100 kbytes I²C interface serial clock rates

| CR2 | CR1 | CR0 | BIT FREQUENCY (kHz) AT f _{OSC} in 6X MODE | | | | | | f _{OSC} DIVIDE BY |
|-----|-----|-----|---|-------------|-------------|-------------|------------|------------|--|
| | | | 3 MHz | 6 MHz | 12 MHz | 16 MHz | 24 MHz | 30 MHz | |
| 0 | 0 | 0 | 23 | 47 | 94 | 125 | 188 | 234 | 128 |
| 0 | 0 | 1 | 27 | 54 | 107 | 143 | 214 | 268 | 112 |
| 0 | 1 | 0 | 31 | 63 | 125 | 167 | 250 | 313 | 96 |
| 0 | 1 | 1 | 38 | 75 | 150 | 200 | 300 | 375 | 80 |
| 1 | 0 | 0 | 6 | 13 | 25 | 33 | 50 | 63 | 480 |
| 1 | 0 | 1 | 50 | 100 | 200 | 267 | 400 | 500 | 60 |
| 1 | 1 | 0 | 100 | 200 | 400 | 533 | 800 | 1000 | 30 |
| 1 | 1 | 1 | 0.2 to 31.2 | 0.5 to 62.5 | 1.0 to 125 | 1.3 to 167 | 2.0 to 250 | 2.4 to 313 | 48x(256-(reload value Timer1)) Mode 2 value range: 0 to 254 |
| CR2 | CR1 | CR0 | BIT FREQUENCY (kHz) AT f _{OSC} in 12X MODE | | | | | | f _{OSC} DIVIDE BY |
| | | | 3 MHz | 6 MHz | 12 MHz | 16 MHz | 24 MHz | 33 MHz | |
| 0 | 0 | 0 | 12 | 23 | 47 | 63 | 94 | 129 | 256 |
| 0 | 0 | 1 | 13 | 27 | 54 | 71 | 107 | 147 | 224 |
| 0 | 1 | 0 | 16 | 31 | 63 | 83 | 125 | 172 | 192 |
| 0 | 1 | 1 | 19 | 38 | 75 | 100 | 150 | 206 | 160 |
| 1 | 0 | 0 | 3 | 6 | 13 | 17 | 25 | 34 | 960 |
| 1 | 0 | 1 | 25 | 50 | 100 | 133 | 200 | 275 | 120 |
| 1 | 1 | 0 | 50 | 100 | 200 | 267 | 400 | 550 | 60 |
| 1 | 1 | 1 | 0.1 to 15.6 | 0.2 to 31.3 | 0.5 to 62.5 | 0.7 to 83.3 | 1.0 to 125 | 1.3 to 172 | 96x(256-(reload value Timer1)) Mode 2 value range: 0 to 254 |

80C51 8-bit microcontroller family 16 KB OTP/ROM, 512B RAM, low voltage (2.7 to 5.5 V), low power, high speed (30/33 MHz), two 400KB I²C interfaces

P8xC660X2/661X2

More Information on SIO1 Operating Modes: The four operating modes are:

- Master Transmitter
- Master Receiver
- Slave Receiver
- Slave Transmitter

Data transfers in each mode of operation are shown in Figures 22–25. These figures contain the following abbreviations:

| Abbreviation | Explanation |
|--------------|---|
| S | Start condition |
| SLA | 7-bit slave address |
| R | Read bit (HIGH level at SDA) |
| W | Write bit (LOW level at SDA) |
| A | Acknowledge bit (LOW level at SDA) |
| \bar{A} | Not acknowledge bit (HIGH level at SDA) |
| Data | 8-bit data byte |
| P | Stop condition |

In Figures 22-25, circles are used to indicate when the serial interrupt flag is set. The numbers in the circles show the status code held in the S1STA register. At these points, a service routine must be executed to continue or complete the serial transfer. These service routines are not critical since the serial transfer is suspended until the serial interrupt flag is cleared by software.

When a serial interrupt routine is entered, the status code in S1STA is used to branch to the appropriate service routine. For each status code, the required software action and details of the following serial transfer are given in Tables 9-13.

Master Transmitter Mode: In the master transmitter mode, a number of data bytes are transmitted to a slave receiver (see Figure 22). Before the master transmitter mode can be entered, S1CON must be initialized as follows:

| | | | | | | | | |
|-------------|----------|------|-----|-----|----|----|----------|-----|
| | 7 | 6 | 5 | 4 | 3 | 2 | 1 | 0 |
| S1CON (D8H) | CR2 | ENS1 | STA | STO | SI | AA | CR1 | CR0 |
| | bit rate | 1 | 0 | 0 | 0 | X | bit rate | |

CR0, CR1, and CR2 define the serial bit rate. ENS1 must be set to logic 1 to enable SIO1. If the AA bit is reset, SIO1 will not acknowledge its own slave address or the general call address in the event of another device becoming master of the bus. In other words, if AA is reset, SIO0 cannot enter a slave mode. STA, STO, and SI must be reset.

The master transmitter mode may now be entered by setting the STA bit using the SETB instruction. The SIO1 logic will now test the I²C bus and generate a start condition as soon as the bus becomes free. When a START condition is transmitted, the serial interrupt flag (SI) is set, and the status code in the status register (S1STA) will be 08H. This status code must be used to vector to an interrupt service routine that loads S1DAT with the slave address and the data direction bit (SLA+W). The SI bit in S1CON must then be reset before the serial transfer can continue.

When the slave address and the direction bit have been transmitted and an acknowledgment bit has been received, the serial interrupt flag (SI) is set again, and a number of status codes in S1STA are possible. There are 18H, 20H, or 38H for the master mode and also 68H, 78H, or B0H if the slave mode was enabled (AA = logic 1). The appropriate action to be taken for each of these status codes is detailed in Table 9. After a repeated start condition (state 10H). SIO1

may switch to the master receiver mode by loading S1DAT with SLA+R).

Master Receiver Mode: In the master receiver mode, a number of data bytes are received from a slave transmitter (see Figure 23). The transfer is initialized as in the master transmitter mode. When the start condition has been transmitted, the interrupt service routine must load S1DAT with the 7-bit slave address and the data direction bit (SLA+R). The SI bit in S1CON must then be cleared before the serial transfer can continue.

When the slave address and the data direction bit have been transmitted and an acknowledgment bit has been received, the serial interrupt flag (SI) is set again, and a number of status codes in S1STA are possible. These are 40H, 48H, or 38H for the master mode and also 68H, 78H, or B0H if the slave mode was enabled (AA = logic 1). The appropriate action to be taken for each of these status codes is detailed in Table 10. ENS1, CR1, and CR0 are not affected by the serial transfer and are not referred to in Table 10. After a repeated start condition (state 10H), SIO1 may switch to the master transmitter mode by loading S1DAT with SLA+W.

Slave Receiver Mode: In the slave receiver mode, a number of data bytes are received from a master transmitter (see Figure 24). To initiate the slave receiver mode, S1ADR and S1CON must be loaded as follows:

| | | | | | | | | |
|-------------|-------------------|---|---|---|---|---|---|----|
| | 7 | 6 | 5 | 4 | 3 | 2 | 1 | 0 |
| S1ADR (DBH) | X | X | X | X | X | X | X | GC |
| | own slave address | | | | | | | |

The upper 7 bits are the address to which SIO1 will respond when addressed by a master. If the LSB (GC) is set, SIO1 will respond to the general call address (00H); otherwise it ignores the general call address.

| | | | | | | | | |
|-------------|-----|------|-----|-----|----|----|-----|-----|
| | 7 | 6 | 5 | 4 | 3 | 2 | 1 | 0 |
| S1CON (D8H) | CR2 | ENS1 | STA | STO | SI | AA | CR1 | CR0 |
| | X | 1 | 0 | 0 | 0 | 1 | X | X |

CR0, CR1, and CR2 do not affect SIO1 in the slave mode. ENS1 must be set to logic 1 to enable SIO1. The AA bit must be set to enable SIO1 to acknowledge its own slave address or the general call address. STA, STO, and SI must be reset.

When S1ADR and S1CON have been initialized, SIO1 waits until it is addressed by its own slave address followed by the data direction bit which must be "0" (W) for SIO1 to operate in the slave receiver mode. After its own slave address and the W bit have been received, the serial interrupt flag (I) is set and a valid status code can be read from S1STA. This status code is used to vector to an interrupt service routine, and the appropriate action to be taken for each of these status codes is detailed in Table 11. The slave receiver mode may also be entered if arbitration is lost while SIO1 is in the master mode (see status 68H and 78H).

If the AA bit is reset during a transfer, SIO1 will return a not acknowledge (logic 1) to SDA after the next received data byte. While AA is reset, SIO1 does not respond to its own slave address or a general call address. However, the I²C bus is still monitored and address recognition may be resumed at any time by setting AA. This means that the AA bit may be used to temporarily isolate SIO1 from the I²C bus.

80C51 8-bit microcontroller family 16 KB OTP/ROM, 512B RAM, low voltage (2.7 to 5.5 V), low power, high speed (30/33 MHz), two 400KB I²C interfaces

P8xC660X2/661X2

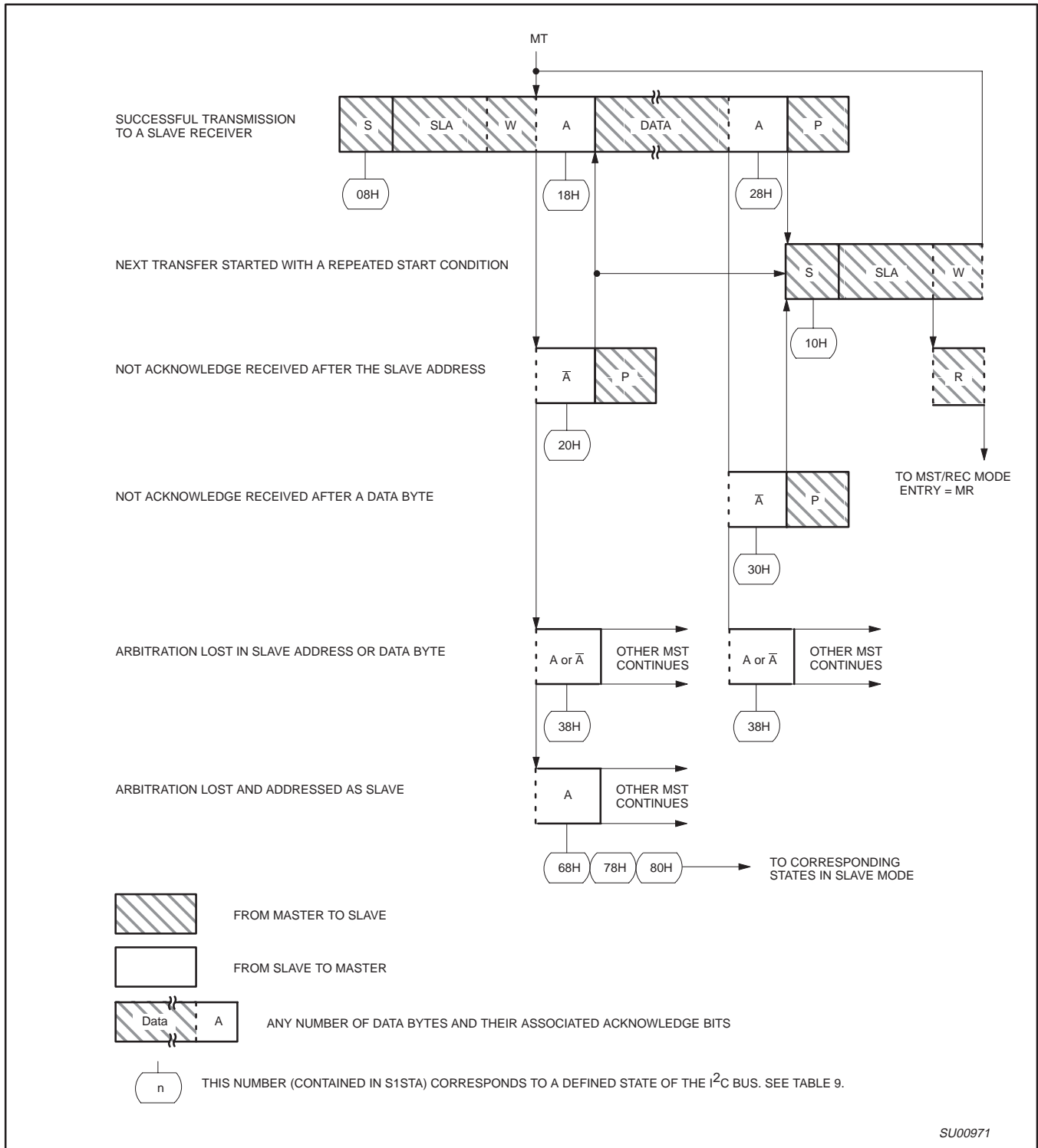

Figure 22. Format and States in the Master Transmitter Mode

SU00971

80C51 8-bit microcontroller family 16 KB OTP/ROM, 512B RAM, low voltage (2.7 to 5.5 V), low power, high speed (30/33 MHz), two 400KB I²C interfaces

P8xC660X2/661X2

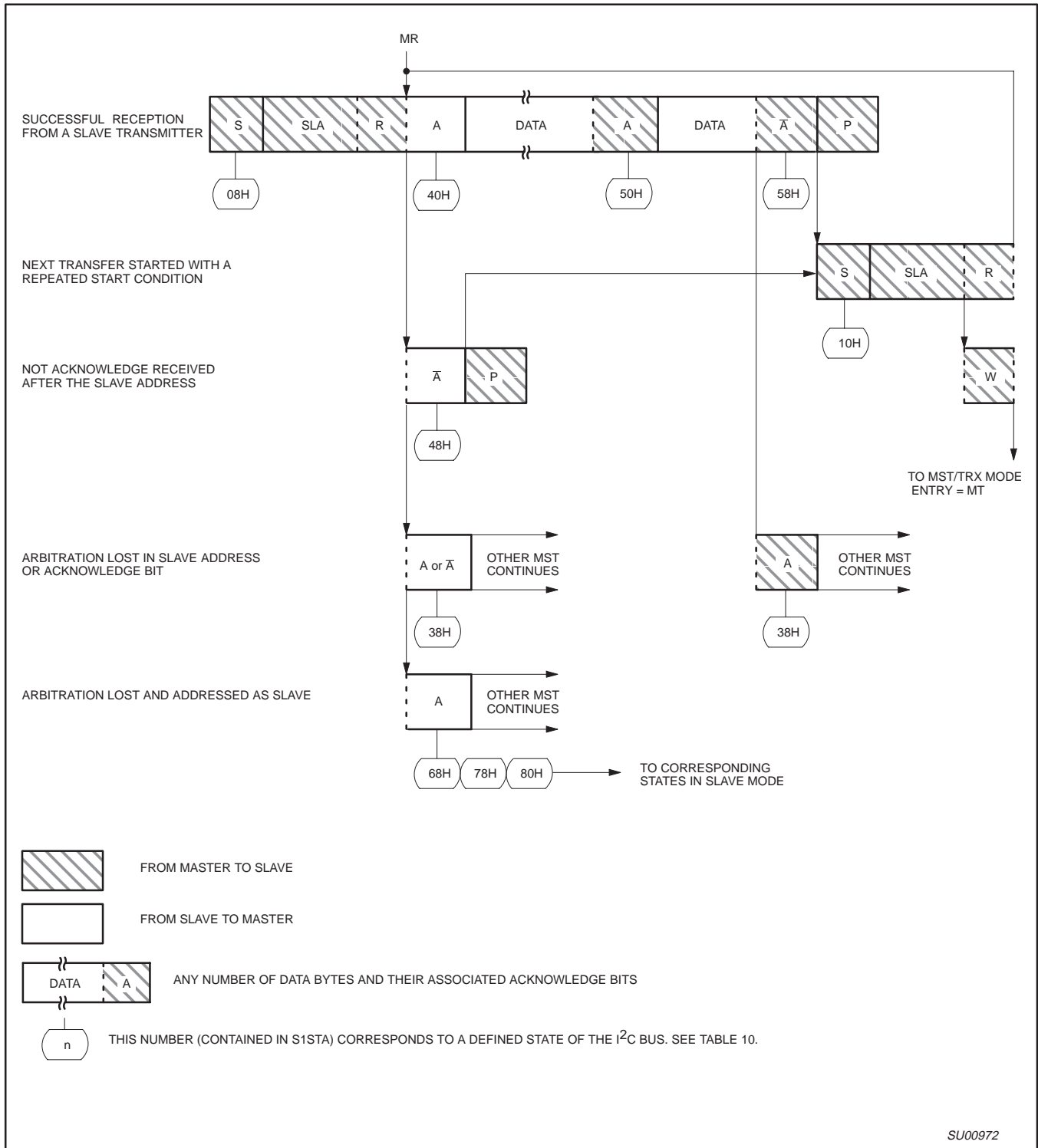

Figure 23. Format and States in the Master Receiver Mode

80C51 8-bit microcontroller family 16 KB OTP/ROM, 512B RAM, low voltage (2.7 to 5.5 V), low power, high speed (30/33 MHz), two 400KB I²C interfaces

P8xC660X2/661X2

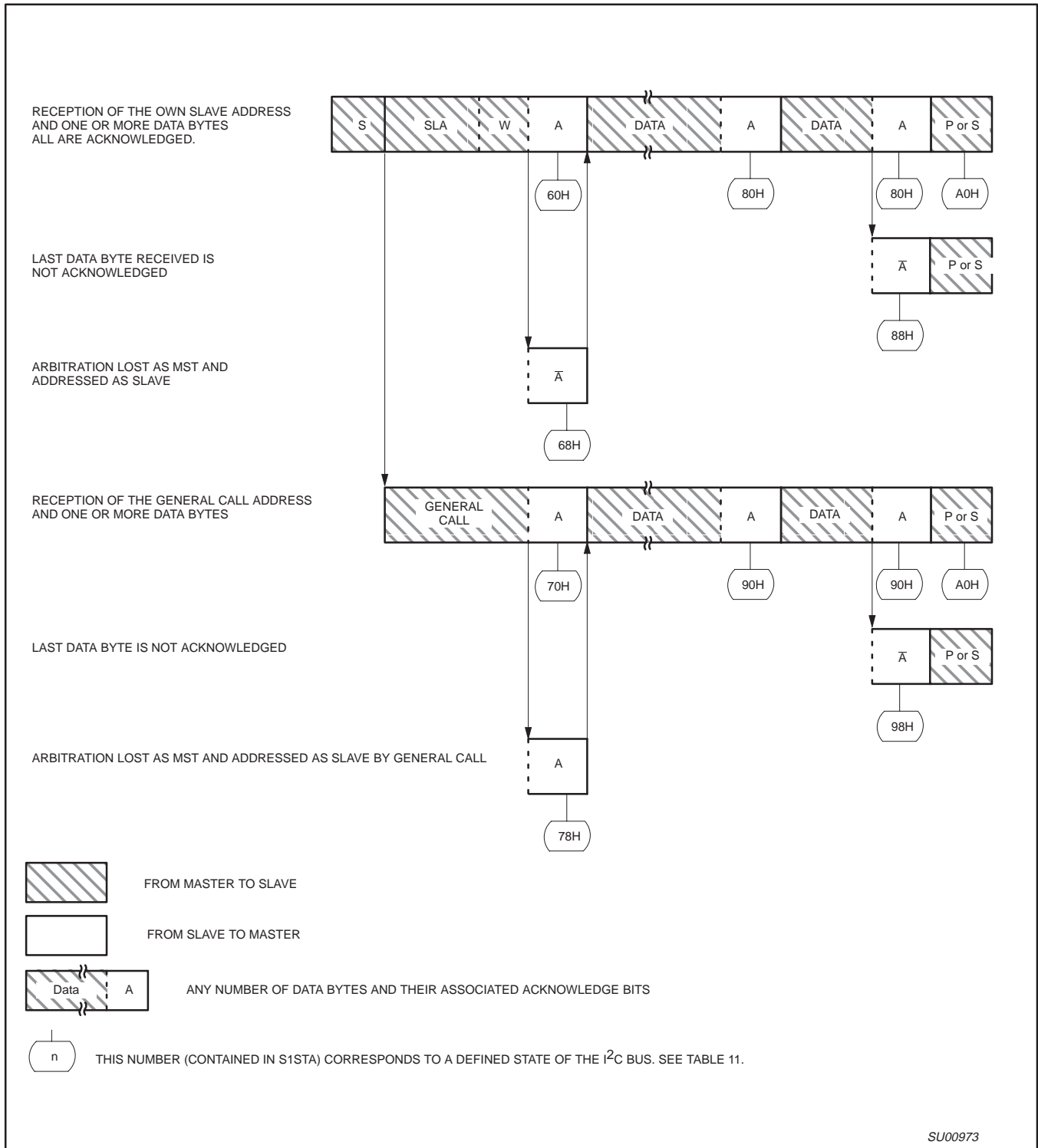

Figure 24. Format and States in the Slave Receiver Mode

80C51 8-bit microcontroller family 16 KB OTP/ROM, 512B RAM, low voltage (2.7 to 5.5 V), low power, high speed (30/33 MHz), two 400KB I²C interfaces

P8xC660X2/661X2

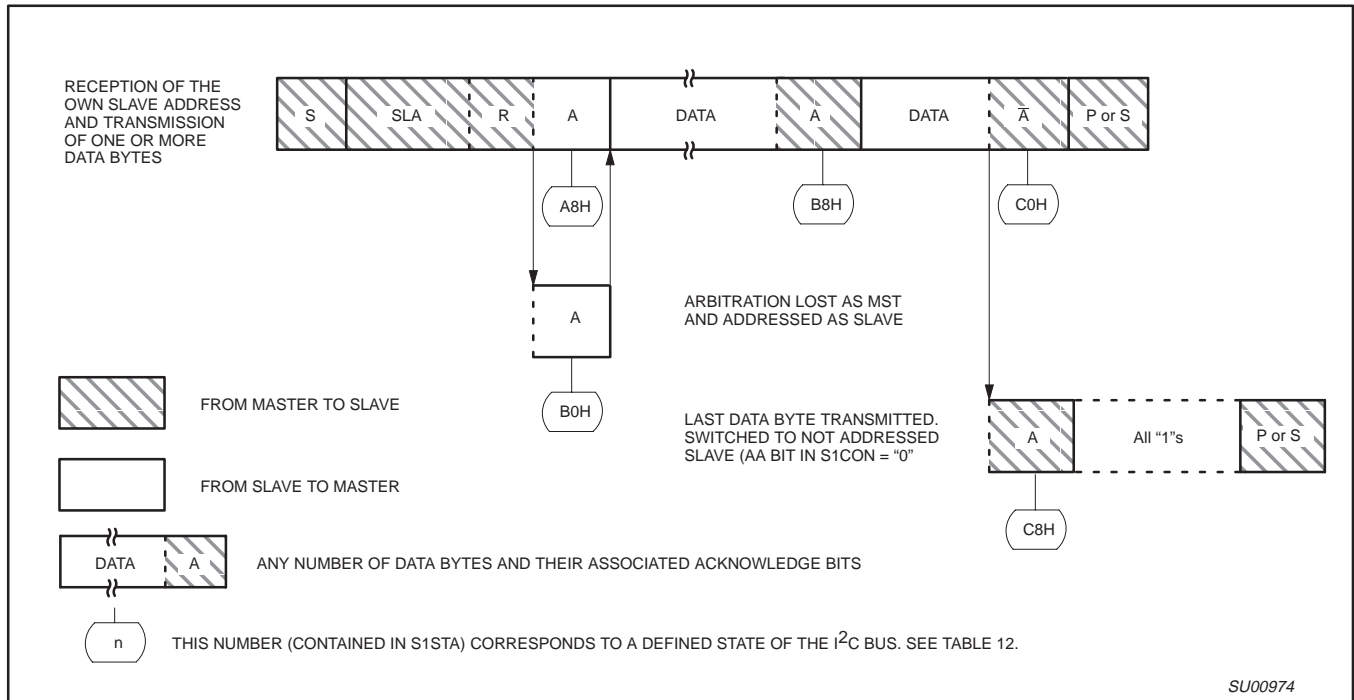

Figure 25. Format and States of the Slave Transmitter Mode

80C51 8-bit microcontroller family 16 KB OTP/ROM, 512B RAM, low voltage (2.7 to 5.5 V), low power, high speed (30/33 MHz), two 400KB I²C interfaces

P8xC660X2/661X2

Table 9. Master Transmitter Mode

| STATUS CODE (S1STA) | STATUS OF THE I ² C BUS AND SIO1 HARDWARE | APPLICATION SOFTWARE RESPONSE | | | | | NEXT ACTION TAKEN BY SIO1 HARDWARE |
|---------------------|--|--|------------------|------------------|------------------|------------------|---|
| | | TO/FROM S1DAT | TO S1CON | | | | |
| | | | STA | STO | SI | AA | |
| 08H | A START condition has been transmitted | Load SLA+W | X | 0 | 0 | X | SLA+W will be transmitted; ACK bit will be received |
| 10H | A repeated START condition has been transmitted | Load SLA+W or Load SLA+R | X X | 0 0 | 0 0 | X X | As above SLA+W will be transmitted; SIO1 will be switched to MST/REC mode |
| 18H | SLA+W has been transmitted; ACK has been received | Load data byte or no S1DAT action or no S1DAT action or no S1DAT action | 0 1 0 1 | 0 0 1 1 | 0 0 0 0 | X X X X | Data byte will be transmitted; ACK bit will be received Repeated START will be transmitted; STOP condition will be transmitted; STO flag will be reset STOP condition followed by a START condition will be transmitted; STO flag will be reset |
| 20H | SLA+W has been transmitted; NOT ACK has been received | Load data byte or no S1DAT action or no S1DAT action or no S1DAT action | 0 1 0 1 | 0 0 1 1 | 0 0 0 0 | X X X X | Data byte will be transmitted; ACK bit will be received Repeated START will be transmitted; STOP condition will be transmitted; STO flag will be reset STOP condition followed by a START condition will be transmitted; STO flag will be reset |
| 28H | Data byte in S1DAT has been transmitted; ACK has been received | Load data byte or no S1DAT action or no S1DAT action or no S1DAT action | 0 1 0 1 | 0 0 1 1 | 0 0 0 0 | X X X X | Data byte will be transmitted; ACK bit will be received Repeated START will be transmitted; STOP condition will be transmitted; STO flag will be reset STOP condition followed by a START condition will be transmitted; STO flag will be reset |
| 30H | Data byte in S1DAT has been transmitted; NOT ACK has been received | Load data byte or no S1DAT action or no S1DAT action or no S1DAT action | 0 1 0 1 | 0 0 1 1 | 0 0 0 0 | X X X X | Data byte will be transmitted; ACK bit will be received Repeated START will be transmitted; STOP condition will be transmitted; STO flag will be reset STOP condition followed by a START condition will be transmitted; STO flag will be reset |
| 38H | Arbitration lost in SLA+R/W or Data bytes | No S1DAT action or No S1DAT action | 0 1 | 0 0 | 0 0 | X X | I ² C bus will be released; not addressed slave will be entered A START condition will be transmitted when the bus becomes free |

80C51 8-bit microcontroller family 16 KB OTP/ROM, 512B RAM, low voltage (2.7 to 5.5 V), low power, high speed (30/33 MHz), two 400KB I²C interfaces

P8xC660X2/661X2

Table 10. Master Receiver Mode

| STATUS CODE (S1STA) | STATUS OF THE I ² C BUS AND SIO1 HARDWARE | APPLICATION SOFTWARE RESPONSE | | | | | NEXT ACTION TAKEN BY SIO1 HARDWARE |
|---------------------|--|---|-------------|-------------|-------------|-------------|--|
| | | TO/FROM S1DAT | TO S1CON | | | | |
| | | | STA | STO | SI | AA | |
| 08H | A START condition has been transmitted | Load SLA+R | X | 0 | 0 | X | SLA+R will be transmitted; ACK bit will be received |
| 10H | A repeated START condition has been transmitted | Load SLA+R or Load SLA+W | X X | 0 0 | 0 0 | X X | As above SLA+W will be transmitted; SIO1 will be switched to MST/TRX mode |
| 38H | Arbitration lost in NOT ACK bit | No S1DAT action or No S1DAT action | 0 1 | 0 0 | 0 0 | X X | I ² C bus will be released; SIO1 will enter a slave mode A START condition will be transmitted when the bus becomes free |
| 40H | SLA+R has been transmitted; ACK has been received | No S1DAT action or no S1DAT action | 0 0 | 0 0 | 0 0 | 0 1 | Data byte will be received; NOT ACK bit will be returned Data byte will be received; ACK bit will be returned |
| 48H | SLA+R has been transmitted; NOT ACK has been received | No S1DAT action or no S1DAT action or no S1DAT action | 1 0 1 | 0 1 1 | 0 0 0 | X X X | Repeated START condition will be transmitted STOP condition will be transmitted; STO flag will be reset STOP condition followed by a START condition will be transmitted; STO flag will be reset |
| 50H | Data byte has been received; ACK has been returned | Read data byte or read data byte | 0 0 | 0 0 | 0 0 | 0 1 | Data byte will be received; NOT ACK bit will be returned Data byte will be received; ACK bit will be returned |
| 58H | Data byte has been received; NOT ACK has been returned | Read data byte or read data byte or read data byte | 1 0 1 | 0 1 1 | 0 0 0 | X X X | Repeated START condition will be transmitted STOP condition will be transmitted; STO flag will be reset STOP condition followed by a START condition will be transmitted; STO flag will be reset |

80C51 8-bit microcontroller family 16 KB OTP/ROM, 512B RAM, low voltage (2.7 to 5.5 V), low power, high speed (30/33 MHz), two 400KB I²C interfaces

P8xC660X2/661X2

Table 11. Slave Receiver Mode

| STATUS CODE (S1STA) | STATUS OF THE I ² C BUS AND SIO1 HARDWARE | APPLICATION SOFTWARE RESPONSE | | | | | NEXT ACTION TAKEN BY SIO1 HARDWARE |
|---------------------|--|-------------------------------|----------|-----|----|----|--|
| | | TO/FROM S1DAT | TO S1CON | | | | |
| | | | STA | STO | SI | AA | |
| 60H | Own SLA+W has been received; ACK has been returned | No S1DAT action or | X | 0 | 0 | 0 | Data byte will be received and NOT ACK will be returned |
| | | no S1DAT action | X | 0 | 0 | 1 | Data byte will be received and ACK will be returned |
| 68H | Arbitration lost in SLA+R/W as master; Own SLA+W has been received, ACK returned | No S1DAT action or | X | 0 | 0 | 0 | Data byte will be received and NOT ACK will be returned |
| | | no S1DAT action | X | 0 | 0 | 1 | Data byte will be received and ACK will be returned |
| 70H | General call address (00H) has been received; ACK has been returned | No S1DAT action or | X | 0 | 0 | 0 | Data byte will be received and NOT ACK will be returned |
| | | no S1DAT action | X | 0 | 0 | 1 | Data byte will be received and ACK will be returned |
| 78H | Arbitration lost in SLA+R/W as master; General call address has been received, ACK has been returned | No S1DAT action or | X | 0 | 0 | 0 | Data byte will be received and NOT ACK will be returned |
| | | no S1DAT action | X | 0 | 0 | 1 | Data byte will be received and ACK will be returned |
| 80H | Previously addressed with own SLV address; DATA has been received; ACK has been returned | Read data byte or | X | 0 | 0 | 0 | Data byte will be received and NOT ACK will be returned |
| | | read data byte | X | 0 | 0 | 1 | Data byte will be received and ACK will be returned |
| 88H | Previously addressed with own SLA; DATA byte has been received; NOT ACK has been returned | Read data byte or | 0 | 0 | 0 | 0 | Switched to not addressed SLV mode; no recognition of own SLA or General call address |
| | | read data byte or | 0 | 0 | 0 | 1 | Switched to not addressed SLV mode; Own SLA will be recognized; General call address will be recognized if S1ADR.0 = logic 1 |
| | | read data byte or | 1 | 0 | 0 | 0 | Switched to not addressed SLV mode; no recognition of own SLA or General call address. A START condition will be transmitted when the bus becomes free |
| | | read data byte | 1 | 0 | 0 | 1 | Switched to not addressed SLV mode; Own SLA will be recognized; General call address will be recognized if S1ADR.0 = logic 1. A START condition will be transmitted when the bus becomes free. |
| 90H | Previously addressed with General Call; DATA byte has been received; ACK has been returned | Read data byte or | X | 0 | 0 | 0 | Data byte will be received and NOT ACK will be returned |
| | | read data byte | X | 0 | 0 | 1 | Data byte will be received and ACK will be returned |
| 98H | Previously addressed with General Call; DATA byte has been received; NOT ACK has been returned | Read data byte or | 0 | 0 | 0 | 0 | Switched to not addressed SLV mode; no recognition of own SLA or General call address |
| | | read data byte or | 0 | 0 | 0 | 1 | Switched to not addressed SLV mode; Own SLA will be recognized; General call address will be recognized if S1ADR.0 = logic 1 |
| | | read data byte or | 1 | 0 | 0 | 0 | Switched to not addressed SLV mode; no recognition of own SLA or General call address. A START condition will be transmitted when the bus becomes free |
| | | read data byte | 1 | 0 | 0 | 1 | Switched to not addressed SLV mode; Own SLA will be recognized; General call address will be recognized if S1ADR.0 = logic 1. A START condition will be transmitted when the bus becomes free. |

80C51 8-bit microcontroller family 16 KB OTP/ROM, 512B RAM, low voltage (2.7 to 5.5 V), low power, high speed (30/33 MHz), two 400KB I²C interfaces

P8xC660X2/661X2

Table 11. Slave Receiver Mode (Continued)

| STATUS CODE (S1STA) | STATUS OF THE I ² C BUS AND SIO1 HARDWARE | APPLICATION SOFTWARE RESPONSE | | | | | NEXT ACTION TAKEN BY SIO1 HARDWARE |
|---------------------|--|-------------------------------|----------|-----|----|----|--|
| | | TO/FROM S1DAT | TO S1CON | | | | |
| | | | STA | STO | SI | AA | |
| A0H | A STOP condition or repeated START condition has been received while still addressed as SLV/REC or SLV/TRX | No STDAT action or | 0 | 0 | 0 | 0 | Switched to not addressed SLV mode; no recognition of own SLA or General call address |
| | | No STDAT action or | 0 | 0 | 0 | 1 | Switched to not addressed SLV mode; Own SLA will be recognized; General call address will be recognized if S1ADR.0 = logic 1 |
| | | No STDAT action or | 1 | 0 | 0 | 0 | Switched to not addressed SLV mode; no recognition of own SLA or General call address. A START condition will be transmitted when the bus becomes free |
| | | No STDAT action | 1 | 0 | 0 | 1 | Switched to not addressed SLV mode; Own SLA will be recognized; General call address will be recognized if S1ADR.0 = logic 1. A START condition will be transmitted when the bus becomes free. |

Table 12. Slave Transmitter Mode

| STATUS CODE (S1STA) | STATUS OF THE I ² C BUS AND SIO1 HARDWARE | APPLICATION SOFTWARE RESPONSE | | | | | NEXT ACTION TAKEN BY SIO1 HARDWARE |
|---------------------|---|-------------------------------|----------|-----|----|----|--|
| | | TO/FROM S1DAT | TO S1CON | | | | |
| | | | STA | STO | SI | AA | |
| A8H | Own SLA+R has been received; ACK has been returned | Load data byte or | X | 0 | 0 | 0 | Last data byte will be transmitted and ACK bit will be received |
| | | load data byte | X | 0 | 0 | 1 | Data byte will be transmitted; ACK will be received |
| B0H | Arbitration lost in SLA+R/W as master; Own SLA+R has been received, ACK has been returned | Load data byte or | X | 0 | 0 | 0 | Last data byte will be transmitted and ACK bit will be received |
| | | load data byte | X | 0 | 0 | 1 | Data byte will be transmitted; ACK bit will be received |
| B8H | Data byte in S1DAT has been transmitted; ACK has been received | Load data byte or | X | 0 | 0 | 0 | Last data byte will be transmitted and ACK bit will be received |
| | | load data byte | X | 0 | 0 | 1 | Data byte will be transmitted; ACK bit will be received |
| C0H | Data byte in S1DAT has been transmitted; NOT ACK has been received | No S1DAT action or | 0 | 0 | 0 | 01 | Switched to not addressed SLV mode; no recognition of own SLA or General call address |
| | | no S1DAT action or | 0 | 0 | 0 | 1 | Switched to not addressed SLV mode; Own SLA will be recognized; General call address will be recognized if S1ADR.0 = logic 1 |
| | | no S1DAT action or | 1 | 0 | 0 | 0 | Switched to not addressed SLV mode; no recognition of own SLA or General call address. A START condition will be transmitted when the bus becomes free |
| | | no S1DAT action | 1 | 0 | 0 | 1 | Switched to not addressed SLV mode; Own SLA will be recognized; General call address will be recognized if S1ADR.0 = logic 1. A START condition will be transmitted when the bus becomes free. |
| C8H | Last data byte in S1DAT has been transmitted (AA = 0); ACK has been received | No S1DAT action or | 0 | 0 | 0 | 0 | Switched to not addressed SLV mode; no recognition of own SLA or General call address |
| | | no S1DAT action or | 0 | 0 | 0 | 1 | Switched to not addressed SLV mode; Own SLA will be recognized; General call address will be recognized if S1ADR.0 = logic 1 |
| | | no S1DAT action or | 1 | 0 | 0 | 0 | Switched to not addressed SLV mode; no recognition of own SLA or General call address. A START condition will be transmitted when the bus becomes free |
| | | no S1DAT action | 1 | 0 | 0 | 1 | Switched to not addressed SLV mode; Own SLA will be recognized; General call address will be recognized if S1ADR.0 = logic 1. A START condition will be transmitted when the bus becomes free. |

80C51 8-bit microcontroller family 16 KB OTP/ROM, 512B RAM, low voltage (2.7 to 5.5 V), low power, high speed (30/33 MHz), two 400KB I²C interfaces

P8xC660X2/661X2

Table 13. Miscellaneous States

| STATUS CODE (S1STA) | STATUS OF THE I ² C BUS AND SIO1 HARDWARE | APPLICATION SOFTWARE RESPONSE | | | | | NEXT ACTION TAKEN BY SIO1 HARDWARE |
|---------------------|--|-------------------------------|-----------------|-----|----|----|---|
| | | TO/FROM S1DAT | TO S1CON | | | | |
| | | | STA | STO | SI | AA | |
| F8H | No relevant state information available; SI = 0 | No S1DAT action | No S1CON action | | | | Wait or proceed current transfer |
| 00H | Bus error during MST or selected slave modes, due to an illegal START or STOP condition. State 00H can also occur when interference causes SIO1 to enter an undefined state. | No S1DAT action | 0 | 1 | 0 | X | Only the internal hardware is affected in the MST or addressed SLV modes. In all cases, the bus is released and SIO1 is switched to the not addressed SLV mode. STO is reset. |

Slave Transmitter Mode: In the slave transmitter mode, a number of data bytes are transmitted to a master receiver (see Figure 25). Data transfer is initialized as in the slave receiver mode. When S1ADR and S1CON have been initialized, SIO1 waits until it is addressed by its own slave address followed by the data direction bit which must be "1" (R) for SIO1 to operate in the slave transmitter mode. After its own slave address and the R bit have been received, the serial interrupt flag (SI) is set and a valid status code can be read from S1STA. This status code is used to vector to an interrupt service routine, and the appropriate action to be taken for each of these status codes is detailed in Table 12. The slave transmitter mode may also be entered if arbitration is lost while SIO1 is in the master mode (see state B0H).

If the AA bit is reset during a transfer, SIO1 will transmit the last byte of the transfer and enter state C0H or C8H. SIO1 is switched to the not addressed slave mode and will ignore the master receiver if it continues the transfer. Thus the master receiver receives all 1s as serial data. While AA is reset, SIO1 does not respond to its own slave address or a general call address. However, the I²C bus is still monitored, and address recognition may be resumed at any time by setting AA. This means that the AA bit may be used to temporarily isolate SIO1 from the I²C bus.

Miscellaneous States: There are two S1STA codes that do not correspond to a defined SIO1 hardware state (see Table 13). These are discussed below.

S1STA = F8H:

This status code indicates that no relevant information is available because the serial interrupt flag, SI, is not yet set. This occurs between other states and when SIO1 is not involved in a serial transfer.

S1STA = 00H:

This status code indicates that a bus error has occurred during an SIO1 serial transfer. A bus error is caused when a START or STOP condition occurs at an illegal position in the format frame. Examples of such illegal positions are during the serial transfer of an address byte, a data byte, or an acknowledge bit. A bus error may also be caused when external interference disturbs the internal SIO1 signals. When a bus error occurs, SI is set. To recover from a bus error, the STO flag must be set and SI must be cleared. This causes SIO1 to enter the "not addressed" slave mode (a defined state) and to clear the STO flag (no other bits in S1CON are affected). The

SDA and SCL lines are released (a STOP condition is not transmitted).

Some Special Cases: The SIO1 hardware has facilities to handle the following special cases that may occur during a serial transfer:

Simultaneous Repeated START Conditions from Two Masters

A repeated START condition may be generated in the master transmitter or master receiver modes. A special case occurs if another master simultaneously generates a repeated START condition (see Figure 26). Until this occurs, arbitration is not lost by either master since they were both transmitting the same data.

If the SIO1 hardware detects a repeated START condition on the I²C bus before generating a repeated START condition itself, it will release the bus, and no interrupt request is generated. If another master frees the bus by generating a STOP condition, SIO1 will transmit a normal START condition (state 08H), and a retry of the total serial data transfer can commence.

DATA TRANSFER AFTER LOSS OF ARBITRATION

Arbitration may be lost in the master transmitter and master receiver modes (see Figure 18). Loss of arbitration is indicated by the following states in S1STA; 38H, 68H, 78H, and B0H (see Figures 22 and 23).

If the STA flag in S1CON is set by the routines which service these states, then, if the bus is free again, a START condition (state 08H) is transmitted without intervention by the CPU, and a retry of the total serial transfer can commence.

FORCED ACCESS TO THE I²C BUS

In some applications, it may be possible for an uncontrolled source to cause a bus hang-up. In such situations, the problem may be caused by interference, temporary interruption of the bus or a temporary short-circuit between SDA and SCL.

If an uncontrolled source generates a superfluous START or masks a STOP condition, then the I²C bus stays busy indefinitely. If the STA flag is set and bus access is not obtained within a reasonable amount of time, then a forced access to the I²C bus is possible. This is achieved by setting the STO flag while the STA flag is still set. No STOP condition is transmitted. The SIO1 hardware behaves as if a STOP condition was received and is able to transmit a START condition. The STO flag is cleared by hardware (see Figure 27).

80C51 8-bit microcontroller family 16 KB OTP/ROM, 512B RAM, low voltage (2.7 to 5.5 V), low power, high speed (30/33 MHz), two 400KB I²C interfaces

P8xC660X2/661X2

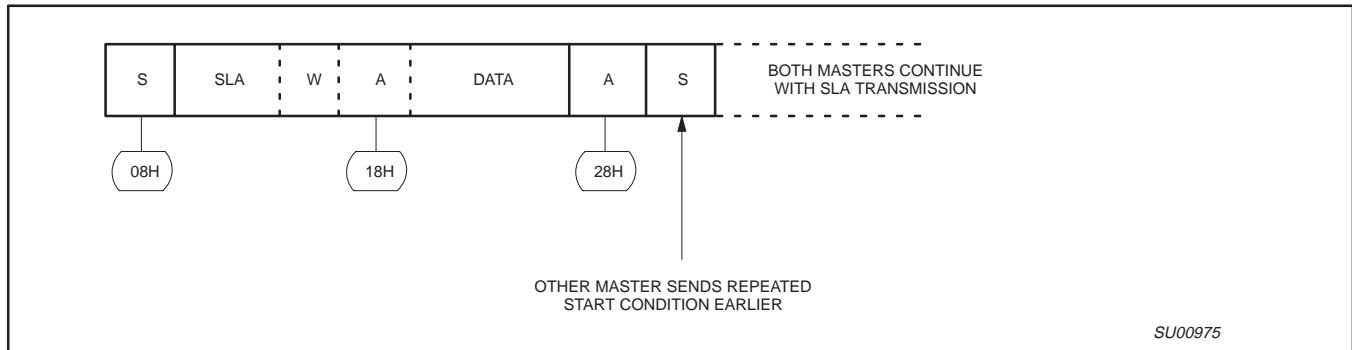

Figure 26. Simultaneous Repeated START Conditions from 2 Masters

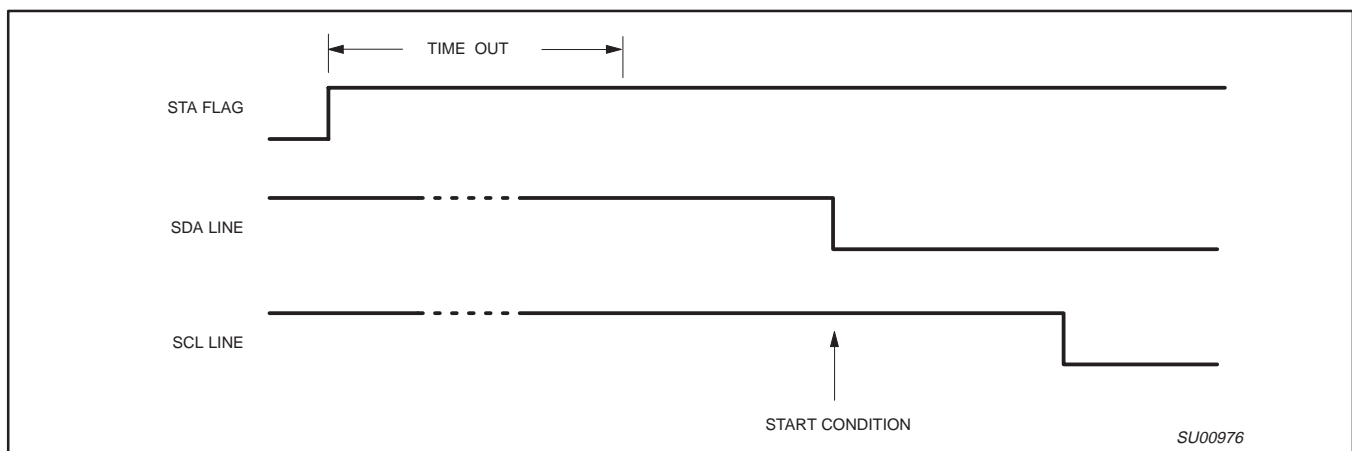

Figure 27. Forced Access to a Busy I²C Bus

I²C BUS OBSTRUCTED BY A LOW LEVEL ON SCL OR SDA
 An I²C bus hang-up occurs if SDA or SCL is pulled LOW by an uncontrolled source. If the SCL line is obstructed (pulled LOW) by a device on the bus, no further serial transfer is possible, and the SIO1 hardware cannot resolve this type of problem. When this occurs, the problem must be resolved by the device that is pulling the SCL bus line LOW.

If the SDA line is obstructed by another device on the bus (e.g., a slave device out of bit synchronization), the problem can be solved by transmitting additional clock pulses on the SCL line (see Figure 28). The SIO1 hardware transmits additional clock pulses when the STA flag is set, but no START condition can be generated because the SDA line is pulled LOW while the I²C bus is considered free. The SIO1 hardware attempts to generate a START condition after every two additional clock pulses on the SCL line. When the SDA line is eventually released, a normal START condition is transmitted, state 08H is entered, and the serial transfer continues.

If a forced bus access occurs or a repeated START condition is transmitted while SDA is obstructed (pulled LOW), the SIO1

hardware performs the same action as described above. In each case, state 08H is entered after a successful START condition is transmitted and normal serial transfer continues. Note that the CPU is not involved in solving these bus hang-up problems.

BUS ERROR

A bus error occurs when a START or STOP condition is present at an illegal position in the format frame. Examples of illegal positions are during the serial transfer of an address byte, a data or an acknowledge bit.

The SIO1 hardware only reacts to a bus error when it is involved in a serial transfer either as a master or an addressed slave. When a bus error is detected, SIO1 immediately switches to the not addressed slave mode, releases the SDA and SCL lines, sets the interrupt flag, and loads the status register with 00H. This status code may be used to vector to a service routine which either attempts the aborted serial transfer again or simply recovers from the error condition as shown in Table 13.

80C51 8-bit microcontroller family 16 KB OTP/ROM, 512B RAM, low voltage (2.7 to 5.5 V), low power, high speed (30/33 MHz), two 400KB I²C interfaces

P8xC660X2/661X2

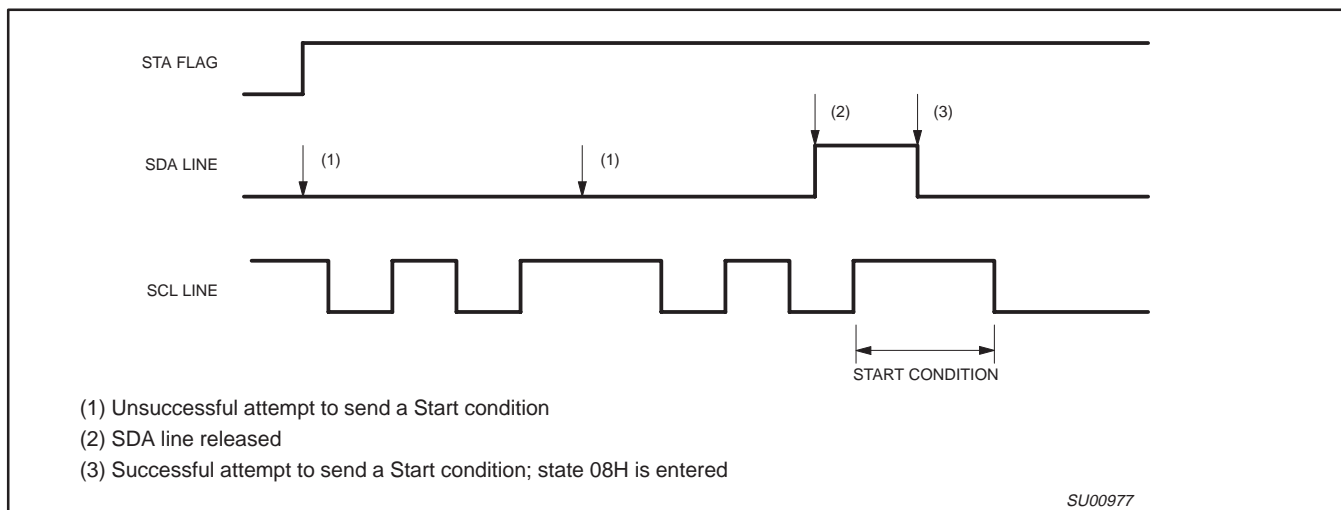

Figure 28. Recovering from a Bus Obstruction Caused by a Low Level on SDA

Software Examples of SIO1 Service Routines: This section consists of a software example for:

- Initialization of SIO1 after a RESET
- Entering the SIO1 interrupt routine
- The 26 state service routines for the
 - Master transmitter mode
 - Master receiver mode
 - Slave receiver mode
 - Slave transmitter mode

INITIALIZATION

In the initialization routine, SIO1 is enabled for both master and slave modes. For each mode, a number of bytes of internal data RAM are allocated to the SIO to act as either a transmission or reception buffer. In this example, 8 bytes of internal data RAM are reserved for different purposes. The data memory map is shown in Figure 29. The initialization routine performs the following functions:

- S1ADR is loaded with the part's own slave address and the general call bit (GC)
- P1.6 and P1.7 bit latches are loaded with logic 1s
- RAM location HADD is loaded with the high-order address byte of the service routines
- The SIO1 interrupt enable and interrupt priority bits are set
- The slave mode is enabled by simultaneously setting the ENS1 and AA bits in S1CON and the serial clock frequency (for master modes) is defined by loading CR0 and CR1 in S1CON. The master routines must be started in the main program.

The SIO1 hardware now begins checking the I²C bus for its own slave address and general call. If the general call or the own slave address is detected, an interrupt is requested and S1STA is loaded with the appropriate state information. The following text describes a fast method of branching to the appropriate service routine.

SIO1 INTERRUPT ROUTINE

When the SIO1 interrupt is entered, the PSW is first pushed on the stack. Then S1STA and HADD (loaded with the high-order address byte of the 26 service routines by the initialization routine) are pushed on to the stack. S1STA contains a status code which is the lower byte of one of the 26 service routines. The next instruction is RET, which is the return from subroutine instruction. When this instruction is executed, the HIGH and LOW order address bytes are popped from stack and loaded into the program counter.

The next instruction to be executed is the first instruction of the state service routine. Seven bytes of program code (which execute in eight machine cycles) are required to branch to one of the 26 state service routines.

```

SI   PUSH  PSW   Save PSW
     PUSH  S1STA Push status code
                          (LOW order address byte)
     PUSH  HADD  Push HIGH order address byte
     RET                               Jump to state service routine
    
```

The state service routines are located in a 256-byte page of program memory. The location of this page is defined in the initialization routine. The page can be located anywhere in program memory by loading data RAM register HADD with the page number. Page 01 is chosen in this example, and the service routines are located between addresses 0100H and 01FFH.

THE STATE SERVICE ROUTINES

The state service routines are located 8 bytes from each other. Eight bytes of code are sufficient for most of the service routines. A few of the routines require more than 8 bytes and have to jump to other locations to obtain more bytes of code. Each state routine is part of the SIO1 interrupt routine and handles one of the 26 states. It ends with a RETI instruction which causes a return to the main program.

80C51 8-bit microcontroller family 16 KB OTP/ROM, 512B RAM, low voltage (2.7 to 5.5 V), low power, high speed (30/33 MHz), two 400KB I²C interfaces

P8xC660X2/661X2

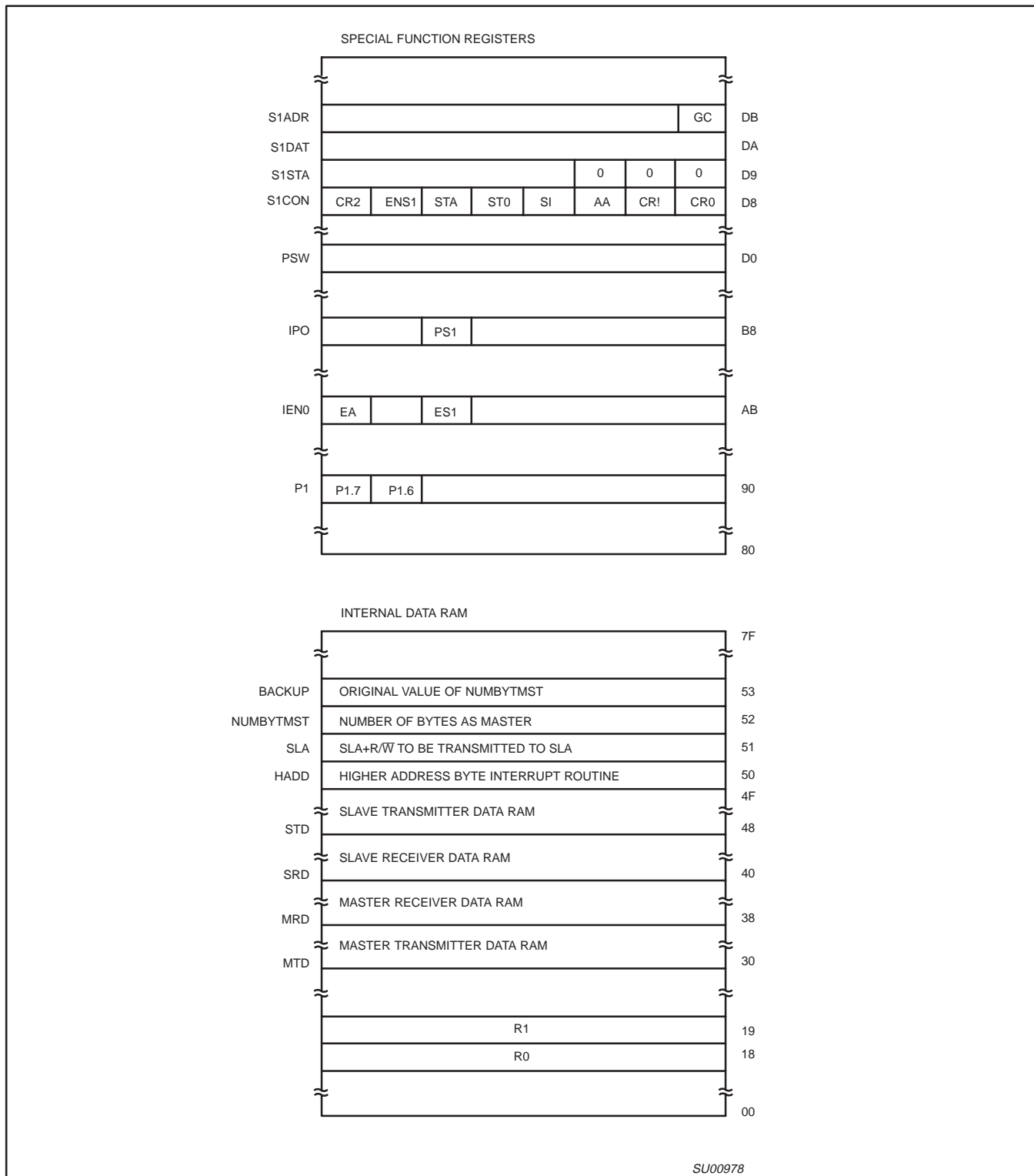

Figure 29. SIO1 Data Memory Map

80C51 8-bit microcontroller family 16 KB OTP/ROM, 512B RAM, low voltage (2.7 to 5.5 V), low power, high speed (30/33 MHz), two 400KB I²C interfaces

P8xC660X2/661X2

MASTER TRANSMITTER AND MASTER RECEIVER MODES

The master mode is entered in the main program. To enter the master transmitter mode, the main program must first load the internal data RAM with the slave address, data bytes, and the number of data bytes to be transmitted. To enter the master receiver mode, the main program must first load the internal data RAM with the slave address and the number of data bytes to be received. The R/W bit determines whether SIO1 operates in the master transmitter or master receiver mode.

Master mode operation commences when the STA bit in S1CION is set by the SETB instruction and data transfer is controlled by the master state service routines in accordance with Table 9, Table 10, Figure 22, and Figure 23. In the example below, 4 bytes are transferred. There is no repeated START condition. In the event of lost arbitration, the transfer is restarted when the bus becomes free. If a bus error occurs, the I²C bus is released and SIO1 enters the not selected slave receiver mode. If a slave device returns a not acknowledge, a STOP condition is generated.

A repeated START condition can be included in the serial transfer if the STA flag is set instead of the STO flag in the state service routines vectored to by status codes 28H and 58H. Additional software must be written to determine which data is transferred after a repeated START condition.

SLAVE TRANSMITTER AND SLAVE RECEIVER MODES

After initialization, SIO1 continually tests the I²C bus and branches to one of the slave state service routines if it detects its own slave address or the general call address (see Table 11, Table 12, Figure 24, and Figure 25). If arbitration was lost while in the master mode, the master mode is restarted after the current transfer. If a bus error

occurs, the I²C bus is released and SIO1 enters the not selected slave receiver mode.

In the slave receiver mode, a maximum of 8 received data bytes can be stored in the internal data RAM. A maximum of 8 bytes ensures that other RAM locations are not overwritten if a master sends more bytes. If more than 8 bytes are transmitted, a not acknowledge is returned, and SIO1 enters the not addressed slave receiver mode. A maximum of one received data byte can be stored in the internal data RAM after a general call address is detected. If more than one byte is transmitted, a not acknowledge is returned and SIO1 enters the not addressed slave receiver mode.

In the slave transmitter mode, data to be transmitted is obtained from the same locations in the internal data RAM that were previously loaded by the main program. After a not acknowledge has been returned by a master receiver device, SIO1 enters the not addressed slave mode.

ADAPTING THE SOFTWARE FOR DIFFERENT APPLICATIONS

The following software example shows the typical structure of the interrupt routine including the 26 state service routines and may be used as a base for user applications. If one or more of the four modes are not used, the associated state service routines may be removed but, care should be taken that a deleted routine can never be invoked.

This example does not include any time-out routines. In the slave modes, time-out routines are not very useful since, in these modes, SIO1 behaves essentially as a passive device. In the master modes, an internal timer may be used to cause a time-out if a serial transfer is not complete after a defined period of time. This time period is defined by the system connected to the I²C bus.

80C51 8-bit microcontroller family 16 KB OTP/ROM, 512B
RAM, low voltage (2.7 to 5.5 V), low power, high speed (30/33
MHz), two 400KB I²C interfaces

P8xC660X2/661X2

```

!*****
! SIO1 EQUATE LIST
!*****
!*****
! LOCATIONS OF THE SIO1 SPECIAL FUNCTION REGISTERS
!*****
00D8      S1CON      -0xd8
00D9      S1STA      -0xd9
00DA      S1DAT      -0xda
00DB      S1ADR      -0xdb

00A8      IEN0       -0xa8
00B8      IP0        -02b8

!*****
! BIT LOCATIONS
!*****
00DD      STA        -0xdd          ! STA bit in S1CON
00BD      SIO1HP     -0xbd          ! IP0, SIO1 Priority bit

!*****
! IMMEDIATE DATA TO WRITE INTO REGISTER S1CON
!*****
00D5      ENS1_NOTSTA_STO_NOTSI_AA_CR0      -0xd5      ! Generates STOP
! (CR0 = 100kHz)
00C5      ENS1_NOTSTA_NOTSTO_NOTSI_AA_CR0   -0xc5      ! Releases BUS and
! ACK
00C1      ENS1_NOTSTA_NOTSTO_NOTSI_NOTAA_CR0 -0xc1      ! Releases BUS and
! NOT ACK
00E5      ENS1_STA_NOTSTO_NOTSI_AA_CR0      -0xe5      ! Releases BUS and
! set STA

!*****
! GENERAL IMMEDIATE DATA
!*****
0031      OWNSLA     -0x31          ! Own SLA+General Call
! must be written into S1ADR
00A0      ENSIO1     -0xa0          ! EA+ES1, enable SIO1 interrupt
! must be written into IEN0
0001      PAG1       -0x01          ! select PAG1 as HADD
00C0      SLAW       -0xc0          ! SLA+W to be transmitted
00C1      SLAR       -0xc1          ! SLA+R to be transmitted
0018      SELRB3    -0x18          ! Select Register Bank 3

!*****
! LOCATIONS IN DATA RAM
!*****
0030      MTD        -0x30          ! MST/TRX/DATA base address
0038      MRD        -0x38          ! MST/REC/DATA base address
0040      SRD        -0x40          ! SLV/REC/DATA base address
0048      STD        -0x48          ! SLV/TRX/DATA base address

0053      BACKUP     -0x53          ! Backup from NUMBYTMST
! To restore NUMBYTMST in case
! of an Arbitration Loss.
0052      NUMBYTMST -0x52          ! Number of bytes to transmit
! or receive as MST.
0051      SLA        -0x51          ! Contains SLA+R/W to be
! transmitted.
0050      HADD       -0x50          ! High Address byte for STATE 0
! till STATE 25.

```

80C51 8-bit microcontroller family 16 KB OTP/ROM, 512B
RAM, low voltage (2.7 to 5.5 V), low power, high speed (30/33
MHz), two 400KB I²C interfaces

P8xC660X2/661X2

```

!*****
! INITIALIZATION ROUTINE
! Example to initialize IIC Interface as slave receiver or slave transmitter and
! start a MASTER TRANSMIT or a MASTER RECEIVE function. 4 bytes will be transmitted or received.
!*****
.sect      strt
.base     0x00
0000      4100                                ajmp  INIT                                ! RESET

.sect      initial
.base     0x200
0200      75DB31      INIT:      mov   S1ADR,#OWNSLA      ! Load own SLA + enable
! general call recognition
0203      D296                setb  P1(6)            ! P1.6 High level.
0205      D297                setb  P1(7)            ! P1.7 High level.
0207      755001             mov   HADD,#PAG1
020A      43A8A0             orl   IENO,#ENSIO1    ! Enable SIO1 interrupt
020D      C2BD                clr   SIO1HP          ! SIO1 interrupt LOW priority
020F      75D8C5             mov   S1CON, #ENS1_NOTSTA_NOTSTO_NOTSI_AA_CR0
! Initialize SLV funct.

!*****

!-----
! START MASTER TRANSMIT FUNCTION
!-----
0212      755204             mov   NUMBYTMST,#0x4    ! Transmit 4 bytes.
0215      7551C0             mov   SLA,#SLAW         ! SLA+W, Transmit funct.
0218      D2DD                setb  STA               ! set STA in S1CON

!-----
! START MASTER RECEIVE FUNCTION
!-----
021A      755204             mov   NUMBYTMST,#0x4    ! Receive 4 bytes.
021D      7551C1             mov   SLA,#SLAR         ! SLA+R, Receive funct.
0220      D2DD                setb  STA               ! set STA in S1CON

!*****
! SIO1 INTERRUPT ROUTINE
!*****
.sect      intvec
.base     0x00                                ! SIO1 interrupt vector

! S1STA and HADD are pushed onto the stack.
! They serve as return address for the RET instruction.
! The RET instruction sets the Program Counter to address HADD,
! S1STA and jumps to the right subroutine.

002B      C0D0                push  psw               ! save psw
002D      C0D9                push  S1STA
002F      C050                push  HADD
0031      22                  ret                     ! JMP to address HADD,S1STA.

!-----
! STATE   : 00, Bus error.
! ACTION  : Enter not addressed SLV mode and release bus. STO reset.
!-----
.sect      st0
.base     0x100
0100      75D8D5             mov   S1CON,#ENS1_NOTSTA_STO_NOTSI_AA_CR0 ! clr SI
! set STO,AA
0103      D0D0                pop   psw
0105      32                  reti

```

80C51 8-bit microcontroller family 16 KB OTP/ROM, 512B
RAM, low voltage (2.7 to 5.5 V), low power, high speed (30/33
MHz), two 400KB I²C interfaces

P8xC660X2/661X2

```

!*****
!*****
! MASTER STATE SERVICE ROUTINES
!*****
! State 08 and State 10 are both for MST/TRX and MST/REC.
! The R/W bit decides whether the next state is within
! MST/TRX mode or within MST/REC mode.
!*****

!-----
! STATE   : 08, A, START condition has been transmitted.
! ACTION  : SLA+R/W are transmitted, ACK bit is received.
!-----
.sect     mts8
.base    0x108

0108     8551DA                mov     S1DAT,SLA                ! Load SLA+R/W
010B     75D8C5                mov     S1CON,#ENS1_NOTSTA_NOTSTO_NOTSI_AA_CR0
                                           ! clr SI

010E     01A0                   ajmp   INITBASE1

!-----
! STATE   : 10, A repeated START condition has been
!          transmitted.
! ACTION  : SLA+R/W are transmitted, ACK bit is received.
!-----
.sect     mts10
.base    0x110

0110     8551DA                mov     S1DAT,SLA                ! Load SLA+R/W
0113     75D8C5                mov     S1CON,#ENS1_NOTSTA_NOTSTO_NOTSI_AA_CR0
                                           ! clr SI

010E     01A0                   ajmp   INITBASE1

.sect     ibase1
.base    0xa0
INITBASE1:
00A0     75D018                mov     psw,#SELRB3
00A3     7930                   mov     r1,#MTD
00A5     7838                   mov     r0,#MRD
00A7     855253                mov     BACKUP,NUMBYTMST        ! Save initial value
00AA     D0D0                   pop     psw
00AC     32                     reti

!*****
!*****
! MASTER TRANSMITTER STATE SERVICE ROUTINES
!*****

!-----
! STATE   : 18, Previous state was STATE 8 or STATE 10, SLA+W have been transmitted,
!          ACK has been received.
! ACTION  : First DATA is transmitted, ACK bit is received.
!-----
.sect     mts18
.base    0x118

0118     75D018                mov     psw,#SELRB3
011B     87DA                   mov     S1DAT,@r1
011D     01B5                   ajmp   CON

```

80C51 8-bit microcontroller family 16 KB OTP/ROM, 512B
RAM, low voltage (2.7 to 5.5 V), low power, high speed (30/33
MHz), two 400KB I²C interfaces

P8xC660X2/661X2

```

!-----
! STATE   : 20, SLA+W have been transmitted, NOT ACK has been received
! ACTION  : Transmit STOP condition.
!-----
.sect     mts20
.base    0x120

0120     75D8D5                mov     S1CON,#ENS1_NOTSTA_STO_NOTSI_AA_CR0
                                           ! set STO, clr SI
0123     D0D0                  pop     psw
0125     32                     reti

!-----
! STATE   : 28, DATA of S1DAT have been transmitted, ACK received.
! ACTION  : If Transmitted DATA is last DATA then transmit a STOP condition,
!           else transmit next DATA.
!-----
.sect     mts28
.base    0x128

0128     D55285                djnz   NUMBYTMST,NOTLDAT1           ! JMP if NOT last DATA
012B     75D8D5                mov     S1CON,#ENS1_NOTSTA_STO_NOTSI_AA_CR0
                                           ! clr SI, set AA
012E     01B9                  ajmp   RETmt

.sect     mts28sb
.base    0x0b0
NOTLDAT1:
00B0     75D018                mov     psw,#SELRB3
00B3     87DA                  mov     S1DAT,@r1
00B5     75D8C5                CON:   mov     S1CON,#ENS1_NOTSTA_NOTSTO_NOTSI_AA_CR0
                                           ! clr SI, set AA
00B8     09                    inc     r1
00B9     D0D0                RETmt  :   pop     psw
00BB     32                     reti

!-----
! STATE   : 30, DATA of S1DAT have been transmitted, NOT ACK received.
! ACTION  : Transmit a STOP condition.
!-----
.sect     mts30
.base    0x130

0130     75D8D5                mov     S1CON,#ENS1_NOTSTA_STO_NOTSI_AA_CR0
                                           ! set STO, clr SI
0133     D0D0                  pop     psw
0135     32                     reti

!-----
! STATE   : 38, Arbitration lost in SLA+W or DATA.
! ACTION  : Bus is released, not addressed SLV mode is entered.
!           A new START condition is transmitted when the IIC bus is free again.
!-----
.sect     mts38
.base    0x138

0138     75D8E5                mov     S1CON,#ENS1_STA_NOTSTO_NOTSI_AA_CR0
013B     855352                mov     NUMBYTMST,BACKUP
013E     01B9                  ajmp   RETmt

```

80C51 8-bit microcontroller family 16 KB OTP/ROM, 512B
RAM, low voltage (2.7 to 5.5 V), low power, high speed (30/33
MHz), two 400KB I²C interfaces

P8xC660X2/661X2

```

!*****
!*****
! MASTER RECEIVER STATE SERVICE ROUTINES
!*****
!*****

!-----
! STATE   : 40, Previous state was STATE 08 or STATE 10,
!         : SLA+R have been transmitted, ACK received.
! ACTION  : DATA will be received, ACK returned.
!-----

.sect     mts40
.base    0x140

0140    75D8C5                mov     S1CON,#ENS1_NOTSTA_NOTSTO_NOTSI_AA_CR0
                                           ! clr STA, STO, SI set AA
0143    D0D0                  pop     psw
        32                    reti

!-----
! STATE   : 48, SLA+R have been transmitted, NOT ACK received.
! ACTION  : STOP condition will be generated.
!-----

.sect     mts48
.base    0x148

0148    75D8D5    STOP:      mov     S1CON,#ENS1_NOTSTA_STO_NOTSI_AA_CR0
                                           ! set STO, clr SI
014B    D0D0                  pop     psw
014D    32                    reti

!-----
! STATE   : 50, DATA have been received, ACK returned.
! ACTION  : Read DATA of S1DAT.
!         : DATA will be received, if it is last DATA
!         : then NOT ACK will be returned else ACK will be returned.
!-----

.sect     mrs50
.base    0x150

0150    75D018                mov     psw,#SELRB3
0153    A6DA                  mov     @r0,S1DAT                ! Read received DATA
0155    01C0                  ajmp   REC1

.sect     mrs50s
.base    0xc0

00C0    D55205    REC1:      djnz   NUMBYTMST,NOTLDAT2
00C3    75D8C1                mov     S1CON,#ENS1_NOTSTA_NOTSTO_NOTSI_NOTAA_CR0
                                           ! clr SI,AA
00C6    8003                  sjmp   RETmr
00C8    75D8C5    NOTLDAT2:  mov     S1CON,#ENS1_NOTSTA_NOTSTO_NOTSI_AA_CR0
                                           ! clr SI, set AA
00CB    08                    RETmr:  inc     r0
00CC    D0D0                  pop     psw
00CE    32                    reti

!-----
! STATE   : 58, DATA have been received, NOT ACK returned.
! ACTION  : Read DATA of S1DAT and generate a STOP condition.
!-----

.sect     mrs58
.base    0x158

0158    75D018                mov     psw,#SELRB3
015B    A6DA                  mov     @R0,S1DAT
015D    80E9                  sjmp   STOP

```

80C51 8-bit microcontroller family 16 KB OTP/ROM, 512B RAM, low voltage (2.7 to 5.5 V), low power, high speed (30/33 MHz), two 400KB I²C interfaces

P8xC660X2/661X2

```

!*****
!*****
! SLAVE RECEIVER STATE SERVICE ROUTINES
!*****
!*****

!-----
! STATE   : 60, Own SLA+W have been received, ACK returned.
! ACTION  : DATA will be received and ACK returned.
!-----

.sect     srs60
.base    0x160
0160     75D8C5          mov     S1CON,#ENS1_NOTSTA_NOTSTO_NOTSI_AA_CR0
                                           ! clr SI, set AA
0163     75D018          mov     psw,#SELRB3
0166     01D0           ajmp   INITSRD

.sect     insrd
.base    0xd0
00D0     7840          INITSRD:  mov     r0,#SRD
00D2     7908          mov     r1,#8
00D4     D0D0          pop     psw
00D6     32           reti

!-----
! STATE   : 68, Arbitration lost in SLA and R/W as MST
!         : Own SLA+W have been received, ACK returned
! ACTION  : DATA will be received and ACK returned.
!         : STA is set to restart MST mode after the bus is free again.
!-----

.sect     srs68
.base    0x168
0168     75D8E5          mov     S1CON,#ENS1_STA_NOTSTO_NOTSI_AA_CR0
016B     75D018          mov     psw,#SELRB3
016E     01D0           ajmp   INITSRD

!-----
! STATE   : 70, General call has been received, ACK returned.
! ACTION  : DATA will be received and ACK returned.
!-----

.sect     srs70
.base    0x170
0170     75D8C5          mov     S1CON,#ENS1_NOTSTA_NOTSTO_NOTSI_AA_CR0
                                           ! clr SI, set AA
0173     75D018          mov     psw,#SELRB3
0176     01D0           ajmp   initsrd
                                           ! Initialize SRD counter

!-----
! STATE   : 78, Arbitration lost in SLA+R/W as MST.
!         : General call has been received, ACK returned.
! ACTION  : DATA will be received and ACK returned.
!         : STA is set to restart MST mode after the bus is free again.
!-----

.sect     srs78
.base    0x178
0178     75D8E5          mov     S1CON,#ENS1_STA_NOTSTO_NOTSI_AA_CR0
017B     75D018          mov     psw,#SELRB3
017E     01D0           ajmp   INITSRD
                                           ! Initialize SRD counter

```

80C51 8-bit microcontroller family 16 KB OTP/ROM, 512B
RAM, low voltage (2.7 to 5.5 V), low power, high speed (30/33
MHz), two 400KB I²C interfaces

P8xC660X2/661X2

```

!-----
! STATE   : 80, Previously addressed with own SLA. DATA received, ACK returned.
! ACTION  : Read DATA.
!         IF received DATA was the last
!         THEN superfluous DATA will be received and NOT ACK returned
!         ELSE next DATA will be received and ACK returned.
!-----
.sect     srs80
.base    0x180

0180     75D018                mov   psw,#SELRB3
0183     A6DA                  mov   @r0,S1DAT          ! Read received DATA
0185     01D8                  ajmp  REC2

.sect     srs80s
.base    0xd8

00D8     D906                 REC2:   djnz  r1,NOTLDAT3
00DA     75D8C1              LDAT:   mov   S1CON,#ENS1_NOTSTA_NOTSTO_NOTSI_NOTAA_CR0
                                           ! clr SI,AA

00DD     D0D0                pop    psw
00DF     32                  reti
00E0     75D8C5              NOTLDAT3: mov  S1CON,#ENS1_NOTSTA_NOTSTO_NOTSI_AA_CR0
                                           ! clr SI, set AA

00E3     08                  inc    r0
00E4     D0D0              RETsr:  pop    psw
00E6     32                  reti

!-----
! STATE   : 88, Previously addressed with own SLA. DATA received NOT ACK returned.
! ACTION  : No save of DATA, Enter NOT addressed SLV mode.
!         Recognition of own SLA. General call recognized, if S1ADR. 0-1.
!-----
.sect     srs88
.base    0x188

0188     75D8C5                mov   S1CON,#ENS1_NOTSTA_NOTSTO_NOTSI_AA_CR0
                                           ! clr SI, set AA
018B     01E4                  ajmp  RETsr

!-----
! STATE   : 90, Previously addressed with general call.
!         DATA has been received, ACK has been returned.
! ACTION  : Read DATA.
!         After General call only one byte will be received with ACK
!         the second DATA will be received with NOT ACK.
!         DATA will be received and NOT ACK returned.
!-----
.sect     srs90
.base    0x190

0190     75D018                mov   psw,#SELRB3
0193     A6DA                  mov   @r0,S1DAT          ! Read received DATA
0195     01DA                  ajmp  LDAT

!-----
! STATE   : 98, Previously addressed with general call.
!         DATA has been received, NOT ACK has been returned.
! ACTION  : No save of DATA, Enter NOT addressed SLV mode.
!         Recognition of own SLA. General call recognized, if S1ADR. 0-1.
!-----
.sect     srs98
.base    0x198

0198     75D8C5                mov   S1CON,#ENS1_NOTSTA_NOTSTO_NOTSI_AA_CR0
                                           ! clr SI, set AA
019B     D0D0                pop    psw
019D     32                  reti

```

80C51 8-bit microcontroller family 16 KB OTP/ROM, 512B
RAM, low voltage (2.7 to 5.5 V), low power, high speed (30/33
MHz), two 400KB I²C interfaces

P8xC660X2/661X2

```

!-----
! STATE   : A0, A STOP condition or repeated START has been received,
!         : while still addressed as SLV/REC or SLV/TRX.
! ACTION  : No save of DATA, Enter NOT addressed SLV mode.
!         : Recognition of own SLA. General call recognized, if S1ADR. 0-1.
!-----
.sect     srsA0
.base    0x1a0

01A0     75D8C5                mov     S1CON,#ENS1_NOTSTA_NOTSTO_NOTSI_AA_CR0
                                           ! clr SI, set AA
01A3     D0D0                  pop     psw
01A5     32                     reti

!-----
! SLAVE TRANSMITTER STATE SERVICE ROUTINES
!-----

!-----
! STATE   : A8, Own SLA+R received, ACK returned.
! ACTION  : DATA will be transmitted, A bit received.
!-----
.sect     stsa8
.base    0x1a8

01A8     8548DA                mov     S1DAT,STD                ! load DATA in S1DAT
01AB     75D8C5                mov     S1CON,#ENS1_NOTSTA_NOTSTO_NOTSI_AA_CR0
                                           ! clr SI, set AA
01AE     01E8                    ajmp   INITBASE2

.sect     ibase2
.base    0xe8
INITBASE2:
00E8     75D018                mov     psw,#SELRB3
00EB     7948                    mov     r1, #STD
00ED     09                      inc     r1
00EE     D0D0                  pop     psw
00F0     32                      reti

!-----
! STATE   : B0, Arbitration lost in SLA and R/W as MST. Own SLA+R received, ACK returned.
! ACTION  : DATA will be transmitted, A bit received.
!         : STA is set to restart MST mode after the bus is free again.
!-----
.sect     stsb0
.base    0x1b0

01B0     8548DA                mov     S1DAT,STD                ! load DATA in S1DAT
01B3     75D8E5                mov     S1CON,#ENS1_STA_NOTSTO_NOTSI_AA_CR0
01B6     01E8                    ajmp   INITBASE2

```

80C51 8-bit microcontroller family 16 KB OTP/ROM, 512B RAM, low voltage (2.7 to 5.5 V), low power, high speed (30/33 MHz), two 400KB I²C interfaces

P8xC660X2/661X2

```

!-----
! STATE   : B8, DATA has been transmitted, ACK received.
! ACTION  : DATA will be transmitted, ACK bit is received.
!-----
.sect     stsb8
.base    0x1b8
01B8     75D018          mov   psw,#SELRB3
01BB     87DA           mov   S1DAT,@r1
01BD     01F8          ajmp  SCON

.sect     scn
.base    0xf8
00F8     75D8C5        SCON:  mov   S1CON,#ENS1_NOTSTA_NOTSTO_NOTSI_AA_CR0
                                ! clr SI, set AA
00FB     09            inc   r1
00FC     D0D0          pop   psw
00FE     32            reti

!-----
! STATE   : C0, DATA has been transmitted, NOT ACK received.
! ACTION  : Enter not addressed SLV mode.
!-----
.sect     stsc0
.base    0x1c0
01C0     75D8C5        mov   S1CON,#ENS1_NOTSTA_NOTSTO_NOTSI_AA_CR0
                                ! clr SI, set AA
01C3     D0D0          pop   psw
01C5     32            reti

!-----
! STATE   : C8, Last DATA has been transmitted (AA=0), ACK received.
! ACTION  : Enter not addressed SLV mode.
!-----
.sect     stsc8
.base    0x1c8
01C8     75D8C5        mov   S1CON,#ENS1_NOTSTA_NOTSTO_NOTSI_AA_CR0
                                ! clr SI, set AA
01CB     D0D0          pop   psw
01CD     32            reti

!*****
!*****
! END OF SIO1 INTERRUPT ROUTINE
!*****
!*****

```

Figure 30. Internal and External Data Memory Address Space with EXTRAM = 0

80C51 8-bit microcontroller family 16 KB OTP/ROM, 512B RAM, low voltage (2.7 to 5.5 V), low power, high speed (30/33 MHz), two 400KB I²C interfaces

P8xC660X2/661X2

Interrupt Priority Structure

The P8xC660X2/661X2 has an 8/9 source four-level interrupt structure (see Table 15).

There are 4 SFRs associated with the four-level interrupt. They are the IE, IEN1, IP, and IPH. (See Figures 31, 32, and 33.) The IPH (Interrupt Priority High) register makes the four-level interrupt structure possible. The IPH is located at SFR address B7H.

The function of the IPH SFR, when combined with the IP SFR, determines the priority of each interrupt. The priority of each interrupt is determined as shown in the following table:

Table 14.

| PRIORITY BITS | | INTERRUPT PRIORITY LEVEL |
|---------------|------|----------------------------|
| IPH.x | IP.x | |
| 0 | 0 | Level 0 (lowest priority) |
| 0 | 1 | Level 1 |
| 1 | 0 | Level 2 |
| 1 | 1 | Level 3 (highest priority) |

Table 15. Interrupt Table P8xC661X2

| SOURCE | POLLING PRIORITY | REQUEST BITS | HARDWARE CLEAR? | VECTOR ADDRESS |
|------------|------------------|---------------------|---------------------------------------|----------------|
| X0 | 1 | IE0 | N (L) ¹ Y (T) ² | 03H |
| SIO1 (I2C) | 2 | – | N | 2BH |
| SIO2 (I2C) | 3 | – | N | 43H |
| T0 | 4 | TP0 | Y | 0BH |
| X1 | 5 | IE1 | N (L) Y (T) | 13H |
| T1 | 6 | TF1 | Y | 1BH |
| SP | 7 | RI, TI | N | 23H |
| T2 | 8 | TF2, EXF2 | N | 3BH |
| PCA | 9 | CF, CCFn n = 0–4 | N | 33H |

NOTES:

- 1. L = Level activated
- 2. T = Transition activated

Table 16. Interrupt Table P8xC662X2

| SOURCE | POLLING PRIORITY | REQUEST BITS | HARDWARE CLEAR? | VECTOR ADDRESS |
|------------|------------------|---------------------|---------------------------------------|----------------|
| X0 | 1 | IE0 | N (L) ¹ Y (T) ² | 03H |
| SIO1 (I2C) | 2 | – | N | 2BH |
| T0 | 3 | TP0 | Y | 0BH |
| X1 | 4 | IE1 | N (L) Y (T) | 13H |
| T1 | 5 | TF1 | Y | 1BH |
| SP | 6 | RI, TI | N | 23H |
| T2 | 7 | TF2, EXF2 | N | 3BH |
| PCA | 8 | CF, CCFn n = 0–4 | N | 33H |

NOTES:

- 1. L = Level activated
- 2. T = Transition activated

The priority scheme for servicing the interrupts is the same as that for the 80C51, except there are four interrupt levels rather than two as on the 80C51. An interrupt will be serviced as long as an interrupt of equal or higher priority is not already being serviced. If an interrupt of equal or higher level priority is being serviced, the new

interrupt will wait until it is finished before being serviced. If a lower priority level interrupt is being serviced, it will be stopped and the new interrupt serviced. When the new interrupt is finished, the lower priority level interrupt that was stopped will be completed.

80C51 8-bit microcontroller family 16 KB OTP/ROM, 512B RAM, low voltage (2.7 to 5.5 V), low power, high speed (30/33 MHz), two 400KB I²C interfaces

P8xC660X2/661X2

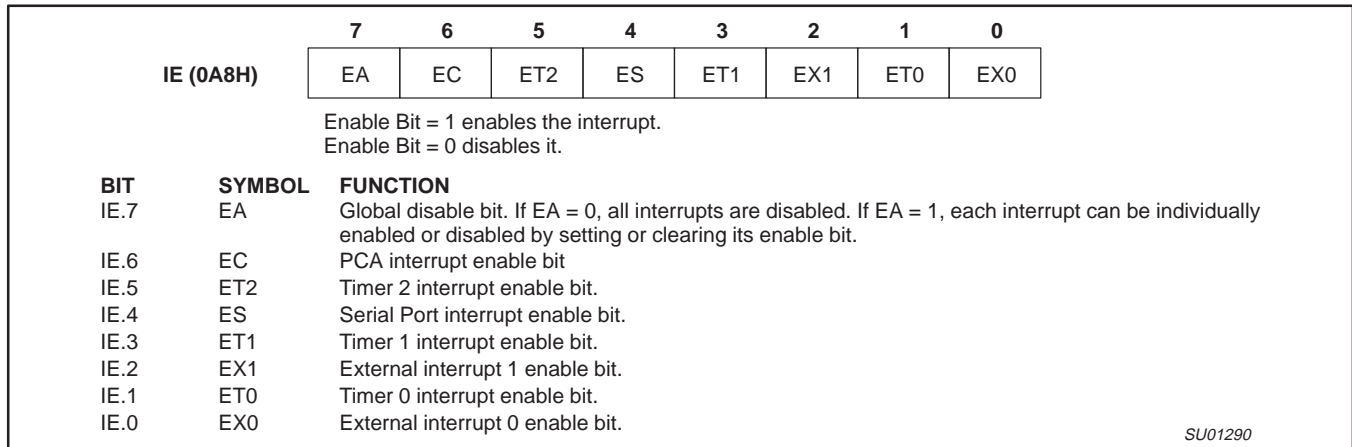

Figure 31. IE Registers

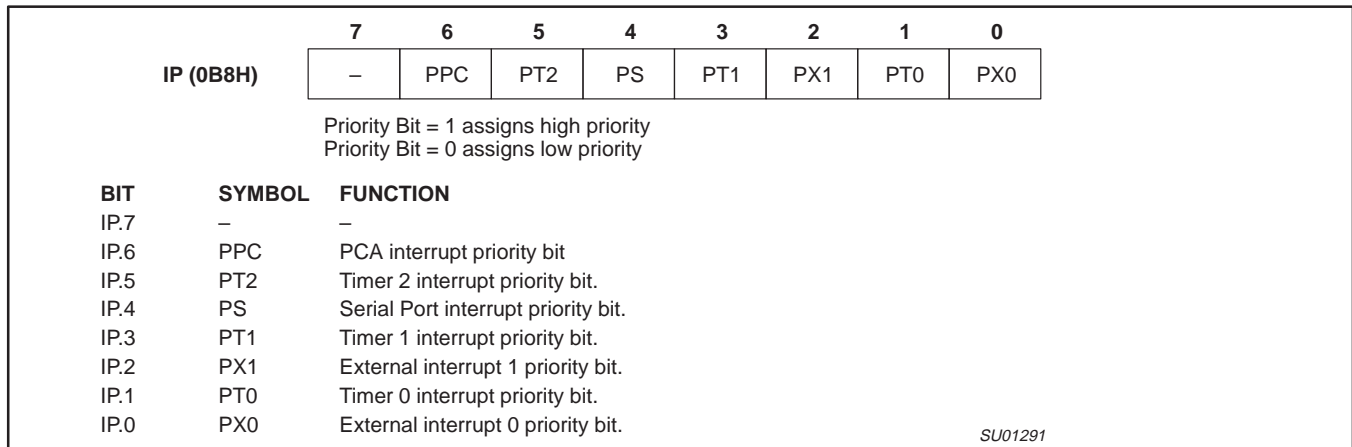

Figure 32. IP Registers

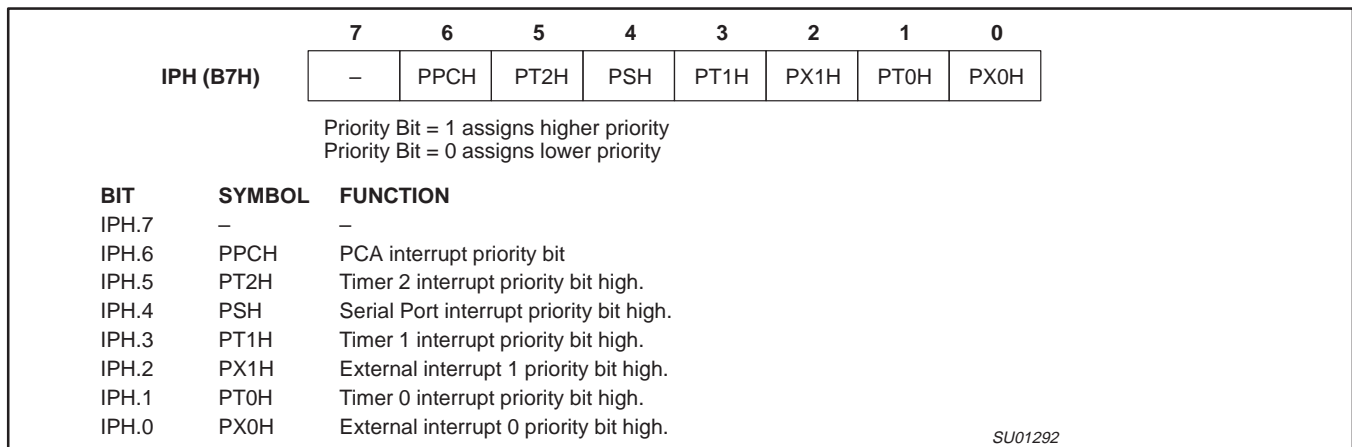

Figure 33. IPH Registers

80C51 8-bit microcontroller family 16 KB OTP/ROM, 512B RAM, low voltage (2.7 to 5.5 V), low power, high speed (30/33 MHz), two 400KB I²C interfaces

P8xC660X2/661X2

Reduced EMI Mode

The AO bit (AUXR.0) in the AUXR register when set disables the ALE output unless the CPU needs to perform an off-chip memory access.

Reduced EMI Mode

AUXR (8EH)

| | | | | | | | |
|---|---|-----|---|---------------------------|---|--------|----|
| 7 | 6 | 5 | 4 | 3 | 2 | 1 | 0 |
| - | - | SRD | - | Fast/STD I ² C | - | EXTRAM | AO |

AUXR.0 AO

See more detailed description in Figure 48.

Dual DPTR

The dual DPTR structure (see Figure 34) is a way by which the chip will specify the address of an external data memory location. There are two 16-bit DPTR registers that address the external memory, and a single bit called DPS = AUXR1/bit0 that allows the program code to switch between them.

- New Register Name: AUXR1#
- SFR Address: A2H
- Reset Value: xxxxxx0B

AUXR1 (A2H)

| | | | | | | | |
|---|---|---|------|-----|---|---|-----|
| 7 | 6 | 5 | 4 | 3 | 2 | 1 | 0 |
| - | - | - | LPEP | GPS | 0 | - | DPS |

Where:

DPS = AUXR1/bit0 = Switches between DPTR0 and DPTR1.

| Select Reg | DPS |
|------------|-----|
| DPTR0 | 0 |
| DPTR1 | 1 |

The DPS bit status should be saved by software when switching between DPTR0 and DPTR1.

The GF2 bit is a general purpose user-defined flag. Note that bit 2 is not writable and is always read as a zero. This allows the DPS bit to be quickly toggled simply by executing an INC AUXR1 instruction without affecting the GF2 bit.

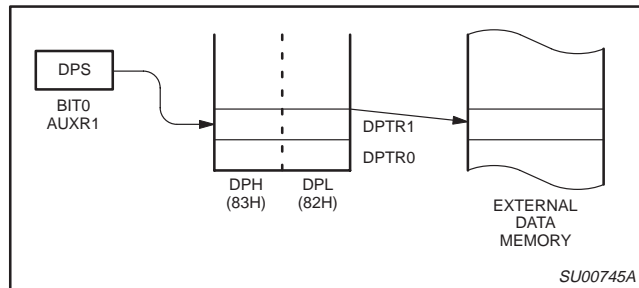

Figure 34.

DPTR Instructions

The instructions that refer to DPTR refer to the data pointer that is currently selected using the AUXR1/bit 0 register. The six instructions that use the DPTR are as follows:

- INC DPTR Increments the data pointer by 1
- MOV DPTR, #data16 Loads the DPTR with a 16-bit constant
- MOV A, @ A+DPTR Move code byte relative to DPTR to ACC
- MOVX A, @ DPTR Move external RAM (16-bit address) to ACC
- MOVX @ DPTR, A Move ACC to external RAM (16-bit address)
- JMP @ A + DPTR Jump indirect relative to DPTR

The data pointer can be accessed on a byte-by-byte basis by specifying the LOW or HIGH byte in an instruction which accesses the SFRs. See *Application Note AN458* for more details.

80C51 8-bit microcontroller family 16 KB OTP/ROM, 512B RAM, low voltage (2.7 to 5.5 V), low power, high speed (30/33 MHz), two 400KB I²C interfaces

P8xC660X2/661X2

Programmable Counter Array (PCA)

The Programmable Counter Array available on the P8xC66xX2 is a special 16-bit Timer that has five 16-bit capture/compare modules associated with it. Each of the modules can be programmed to operate in one of four modes: rising and/or falling edge capture, software timer, high-speed output, or pulse width modulator. Each module has a pin associated with it in port 1. Module 0 is connected to P1.3 (CEX0), module 1 to P1.4 (CEX1), etc. The basic PCA configuration is shown in Figure 35.

The PCA timer is a common time base for all five modules and can be programmed to run at: 1/6 the oscillator frequency, 1/2 the oscillator frequency, the Timer 0 overflow, or the input on the ECI pin (P1.2). The timer count source is determined from the CPS1 and CPS0 bits in the CMOD SFR as follows (see Figure 38):

| CPS1 | CPS0 | PCA Timer Count Source |
|------|------|---|
| 0 | 0 | 1/6 oscillator frequency (6-clock mode); 1/12 oscillator frequency (12-clock mode) |
| 0 | 1 | 1/2 oscillator frequency (6-clock mode); 1/4 oscillator frequency (12-clock mode) |
| 1 | 0 | Timer 0 overflow |
| 1 | 1 | External Input at ECI pin |

In the CMOD SFR are three additional bits associated with the PCA. They are CIDL which allows the PCA to stop during idle mode, WDTE which enables or disables the watchdog function on module 4, and ECF which when set causes an interrupt and the PCA overflow flag CF (in the CCON SFR) to be set when the PCA timer overflows. These functions are shown in Figure 36.

The watchdog timer function is implemented in module 4 (see Figure 45).

The CCON SFR contains the run control bit for the PCA and the flags for the PCA timer (CF) and each module (refer to Figure 39). To run the PCA the CR bit (CCON.6) must be set by software. The PCA is shut off by clearing this bit. The CF bit (CCON.7) is set when

the PCA counter overflows and an interrupt will be generated if the ECF bit in the CMOD register is set, The CF bit can only be cleared by software. Bits 0 through 4 of the CCON register are the flags for the modules (bit 0 for module 0, bit 1 for module 1, etc.) and are set by hardware when either a match or a capture occurs. These flags also can only be cleared by software. The PCA interrupt system shown in Figure 37.

Each module in the PCA has a special function register associated with it. These registers are: CCAPM0 for module 0, CCAPM1 for module 1, etc. (see Figure 40). The registers contain the bits that control the mode that each module will operate in. The ECCF bit (CCAPMn.0 where n=0, 1, 2, 3, or 4 depending on the module) enables the CCF flag in the CCON SFR to generate an interrupt when a match or compare occurs in the associated module. PWM (CCAPMn.1) enables the pulse width modulation mode. The TOG bit (CCAPMn.2) when set causes the CEX output associated with the module to toggle when there is a match between the PCA counter and the module's capture/compare register. The match bit MAT (CCAPMn.3) when set will cause the CCFn bit in the CCON register to be set when there is a match between the PCA counter and the module's capture/compare register.

The next two bits CAPN (CCAPMn.4) and CAPP (CCAPMn.5) determine the edge that a capture input will be active on. The CAPN bit enables the negative edge, and the CAPP bit enables the positive edge. If both bits are set both edges will be enabled and a capture will occur for either transition. The last bit in the register ECOM (CCAPMn.6) when set enables the comparator function. Figure 41 shows the CCAPMn settings for the various PCA functions.

There are two additional registers associated with each of the PCA modules. They are CCAPnH and CCAPnL and these are the registers that store the 16-bit count when a capture occurs or a compare should occur. When a module is used in the PWM mode these registers are used to control the duty cycle of the output.

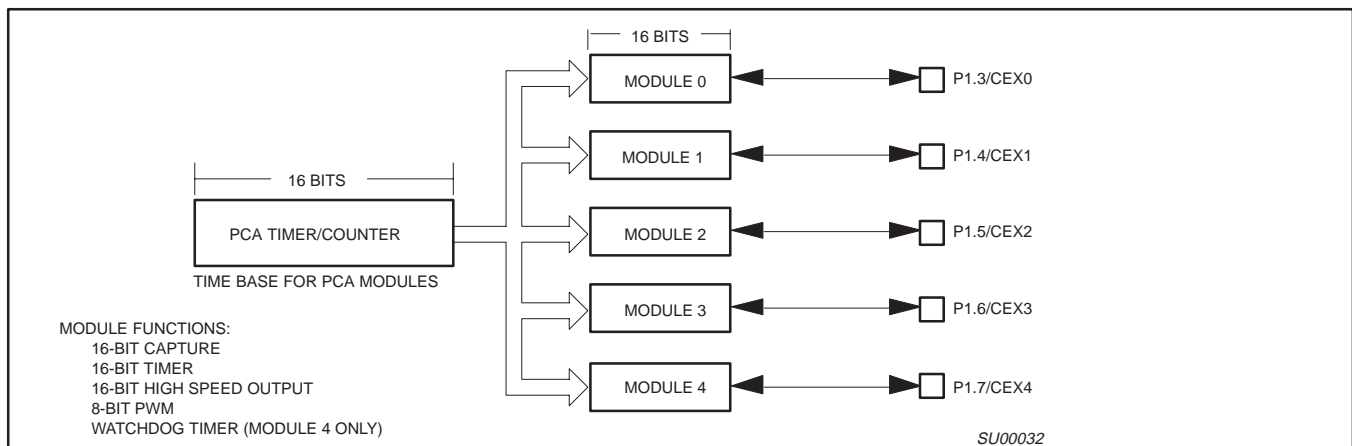

Figure 35. Programmable Counter Array (PCA)

80C51 8-bit microcontroller family 16 KB OTP/ROM, 512B RAM, low voltage (2.7 to 5.5 V), low power, high speed (30/33 MHz), two 400KB I²C interfaces

P8xC660X2/661X2

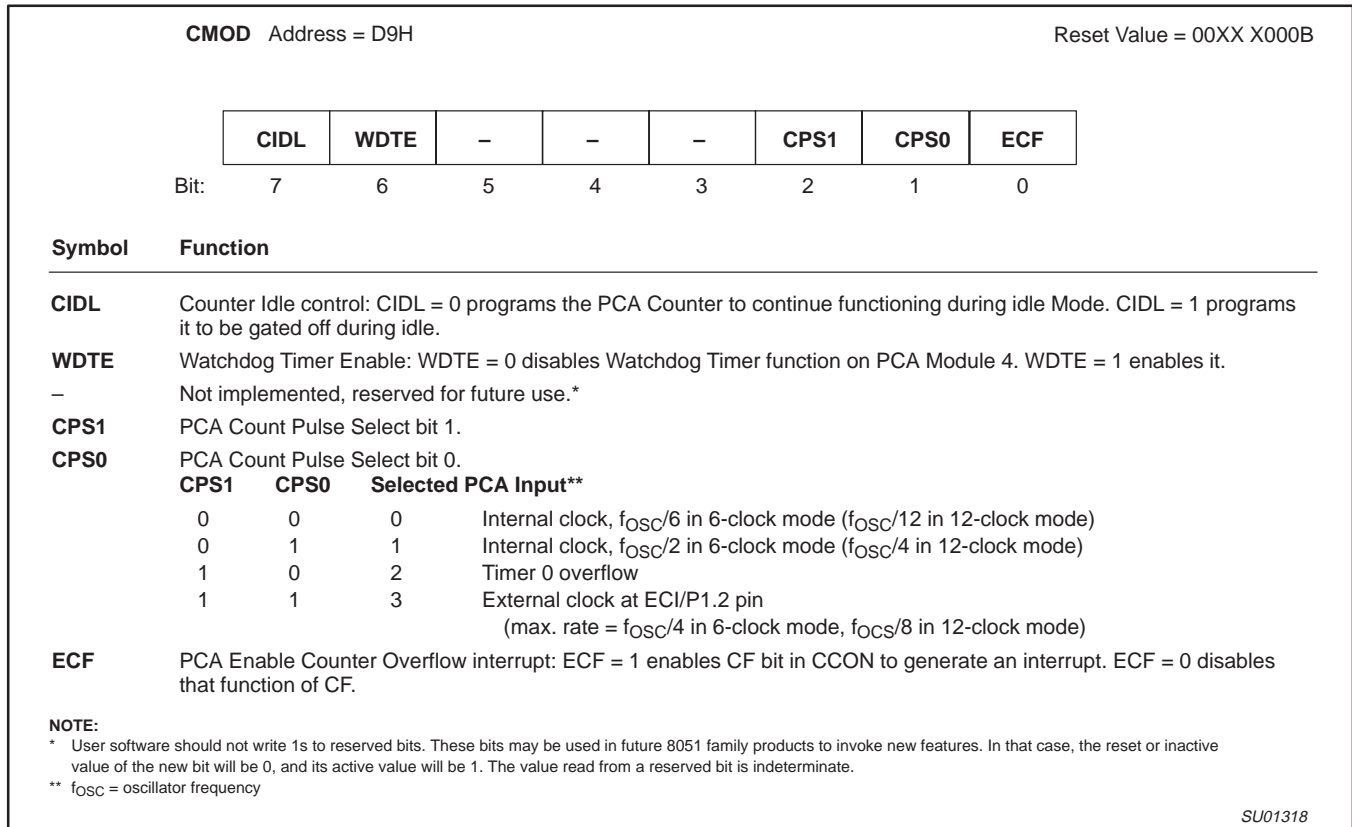

Figure 38. CMOD: PCA Counter Mode Register

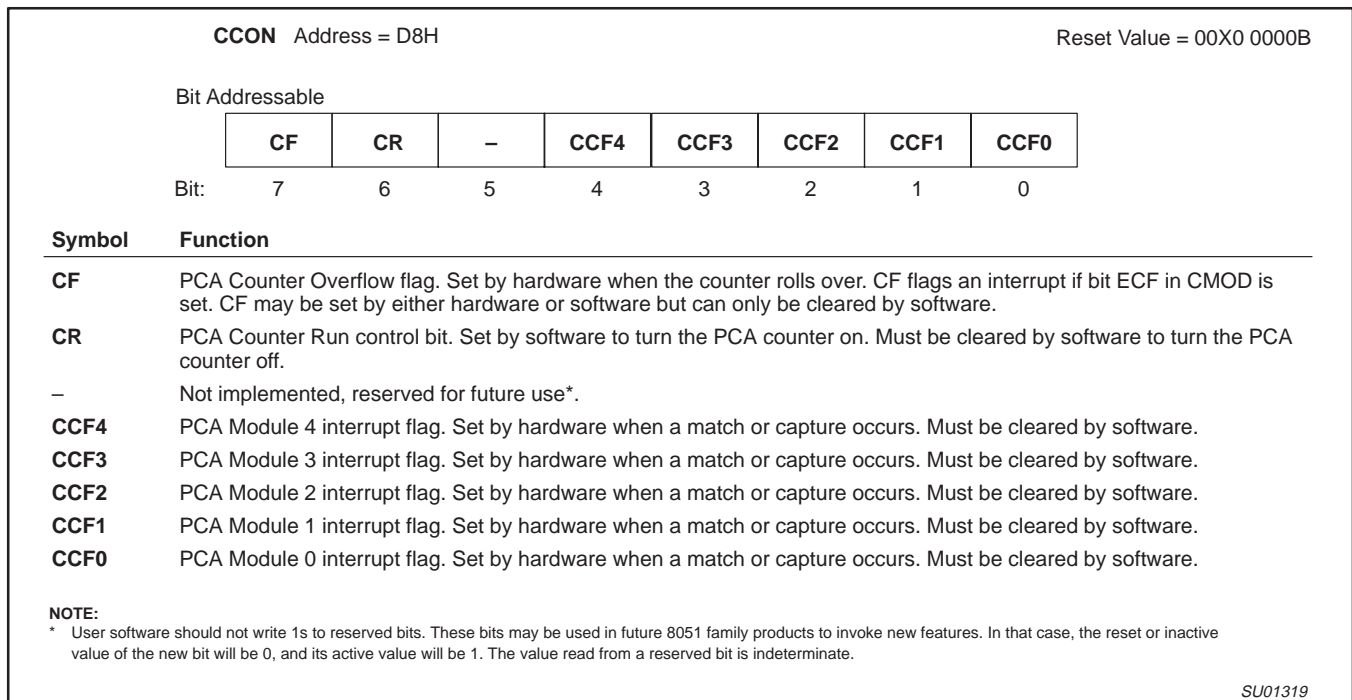

Figure 39. CCON: PCA Counter Control Register

80C51 8-bit microcontroller family 16 KB OTP/ROM, 512B RAM, low voltage (2.7 to 5.5 V), low power, high speed (30/33 MHz), two 400KB I²C interfaces

P8xC660X2/661X2

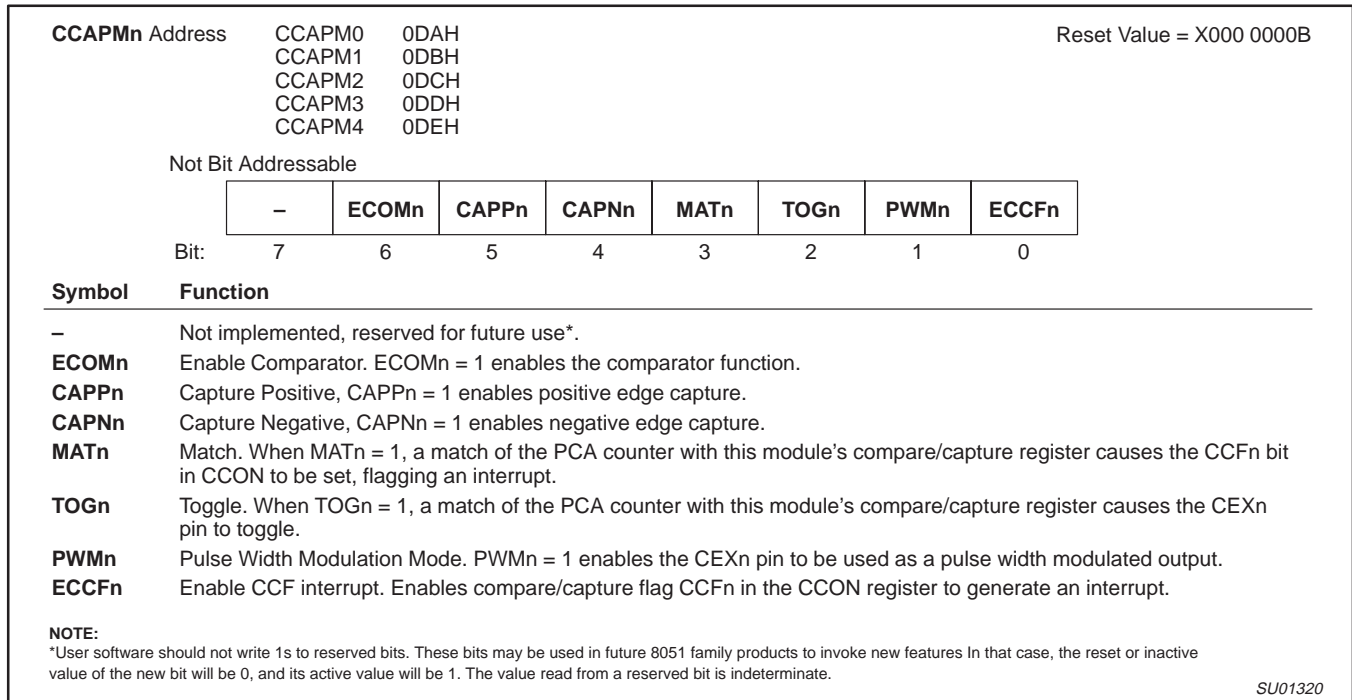

Figure 40. CCAPMn: PCA Modules Compare/Capture Registers

| – | ECOMn | CAPPn | CAPNn | MATn | TOGn | PWMn | ECCFn | MODULE FUNCTION |
|---|-------|-------|-------|------|------|------|-------|---|
| X | 0 | 0 | 0 | 0 | 0 | 0 | 0 | No operation |
| X | X | 1 | 0 | 0 | 0 | 0 | X | 16-bit capture by a positive-edge trigger on CEXn |
| X | X | 0 | 1 | 0 | 0 | 0 | X | 16-bit capture by a negative trigger on CEXn |
| X | X | 1 | 1 | 0 | 0 | 0 | X | 16-bit capture by a transition on CEXn |
| X | 1 | 0 | 0 | 1 | 0 | 0 | X | 16-bit Software Timer |
| X | 1 | 0 | 0 | 1 | 1 | 0 | X | 16-bit High Speed Output |
| X | 1 | 0 | 0 | 0 | 0 | 1 | 0 | 8-bit PWM |
| X | 1 | 0 | 0 | 1 | X | 0 | X | Watchdog Timer |

Figure 41. PCA Module Modes (CCAPMn Register)

PCA Capture Mode

To use one of the PCA modules in the capture mode either one or both of the CCAPM bits CAPN and CAPP for that module must be set. The external CEX input for the module (on port 1) is sampled for a transition. When a valid transition occurs the PCA hardware loads the value of the PCA counter registers (CH and CL) into the module's capture registers (CCAPnL and CCAPnH). If the CCFn bit for the module in the CCON SFR and the ECCFn bit in the CCAPMn SFR are set then an interrupt will be generated. Refer to Figure 42.

16-bit Software Timer Mode

The PCA modules can be used as software timers by setting both the ECOM and MAT bits in the modules CCAPMn register. The PCA timer will be compared to the module's capture registers and when a match occurs an interrupt will occur if the CCFn (CCON SFR) and the ECCFn (CCAPMn SFR) bits for the module are both set (see Figure 43).

High Speed Output Mode

In this mode the CEX output (on port 1) associated with the PCA module will toggle each time a match occurs between the PCA

counter and the module's capture registers. To activate this mode the TOG, MAT, and ECOM bits in the module's CCAPMn SFR must be set (see Figure 44).

Pulse Width Modulator Mode

All of the PCA modules can be used as PWM outputs. Figure 45 shows the PWM function. The frequency of the output depends on the source for the PCA timer. All of the modules will have the same frequency of output because they all share the PCA timer. The duty cycle of each module is independently variable using the module's capture register CCAPLn. When the value of the PCA CL SFR is less than the value in the module's CCAPLn SFR the output will be LOW, when it is equal to or greater than the output will be HIGH. When CL overflows from FF to 00, CCAPLn is reloaded with the value in CCAPHn. the allows updating the PWM without glitches. The PWM and ECOM bits in the module's CCAPMn register must be set to enable the PWM mode.

80C51 8-bit microcontroller family 16 KB OTP/ROM, 512B RAM, low voltage (2.7 to 5.5 V), low power, high speed (30/33 MHz), two 400KB I²C interfaces

P8xC660X2/661X2

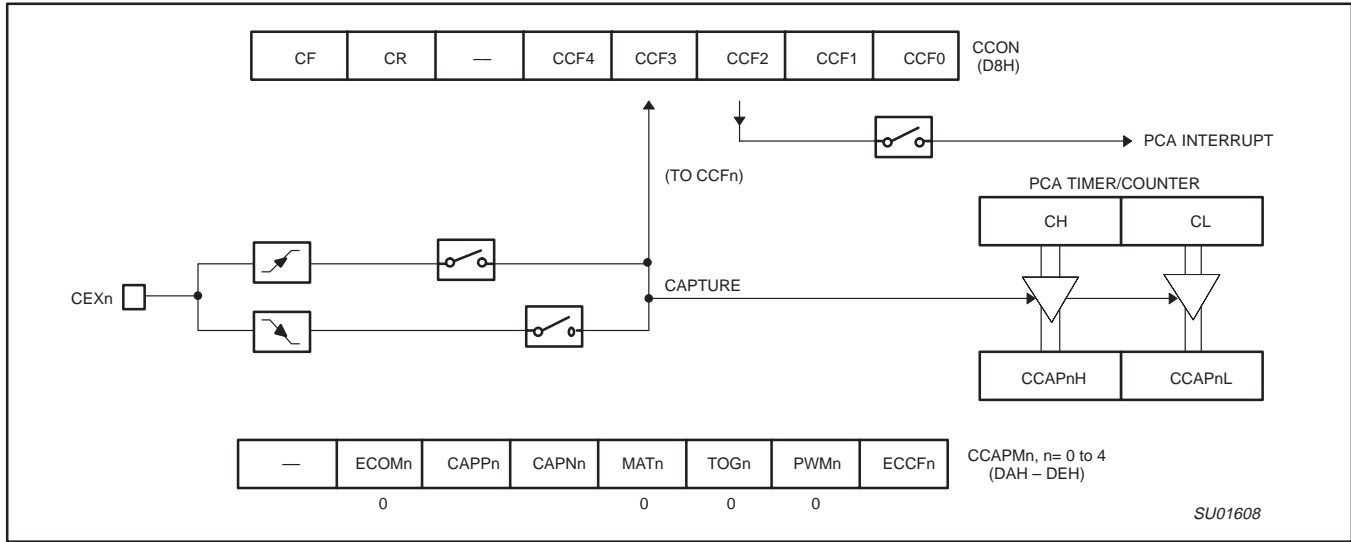

Figure 42. PCA Capture Mode

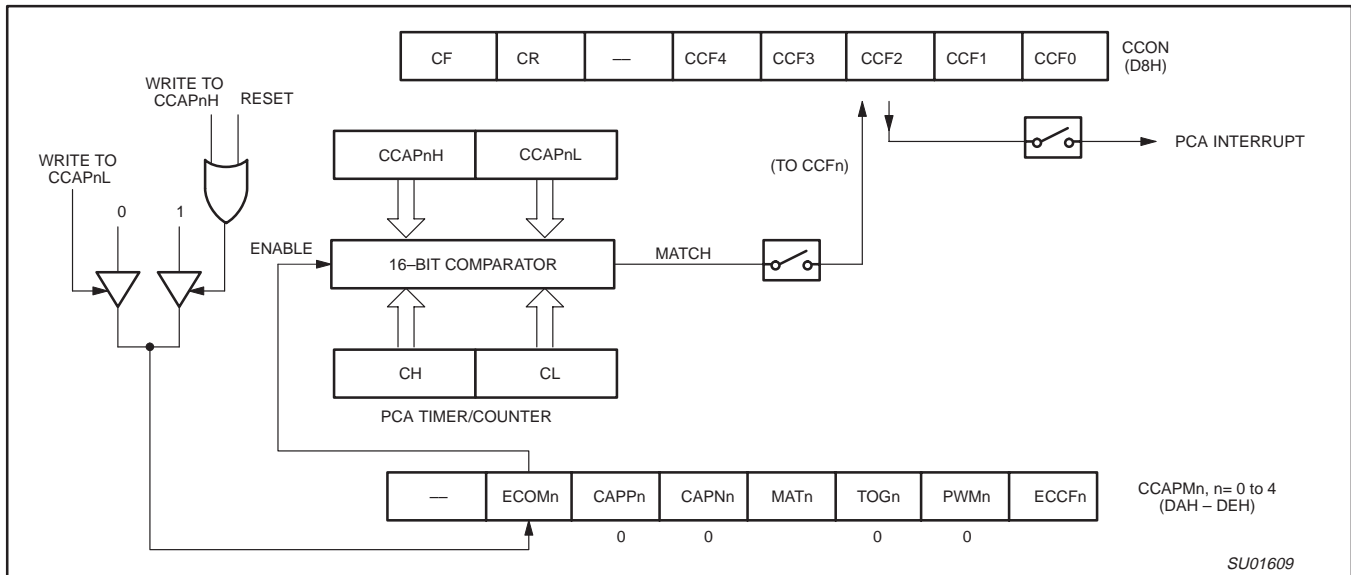

Figure 43. PCA Compare Mode

80C51 8-bit microcontroller family 16 KB OTP/ROM, 512B RAM, low voltage (2.7 to 5.5 V), low power, high speed (30/33 MHz), two 400KB I²C interfaces

P8xC660X2/661X2

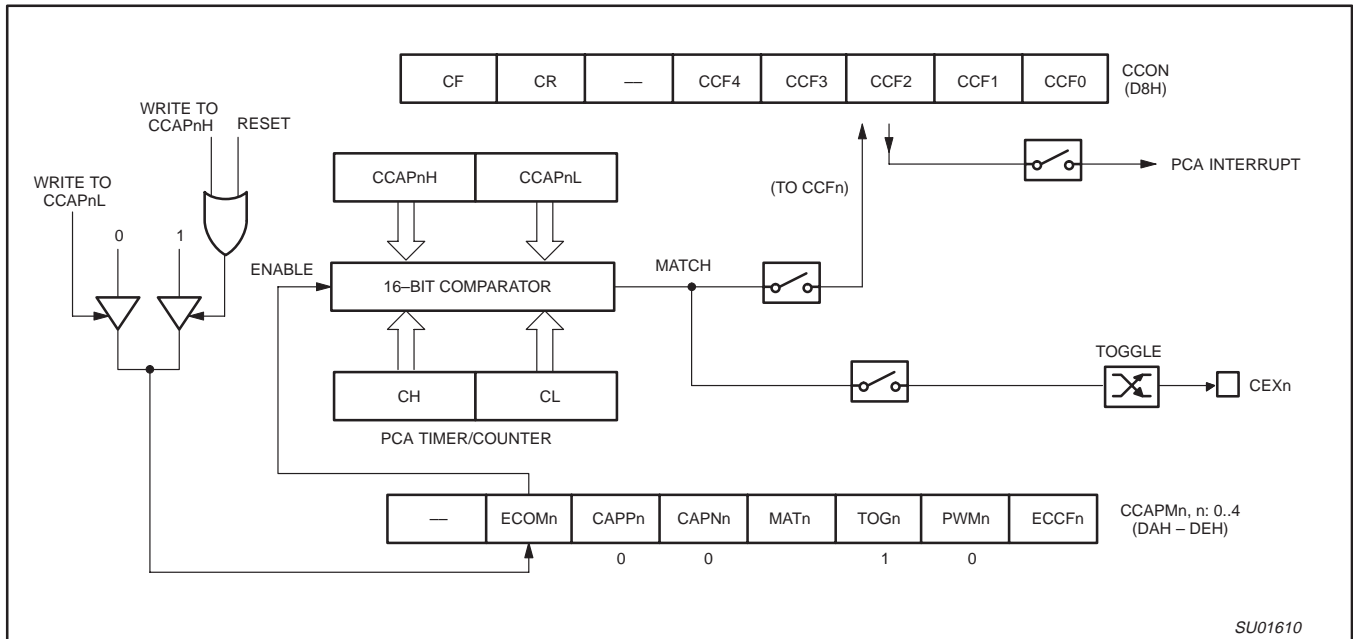

Figure 44. PCA High Speed Output Mode

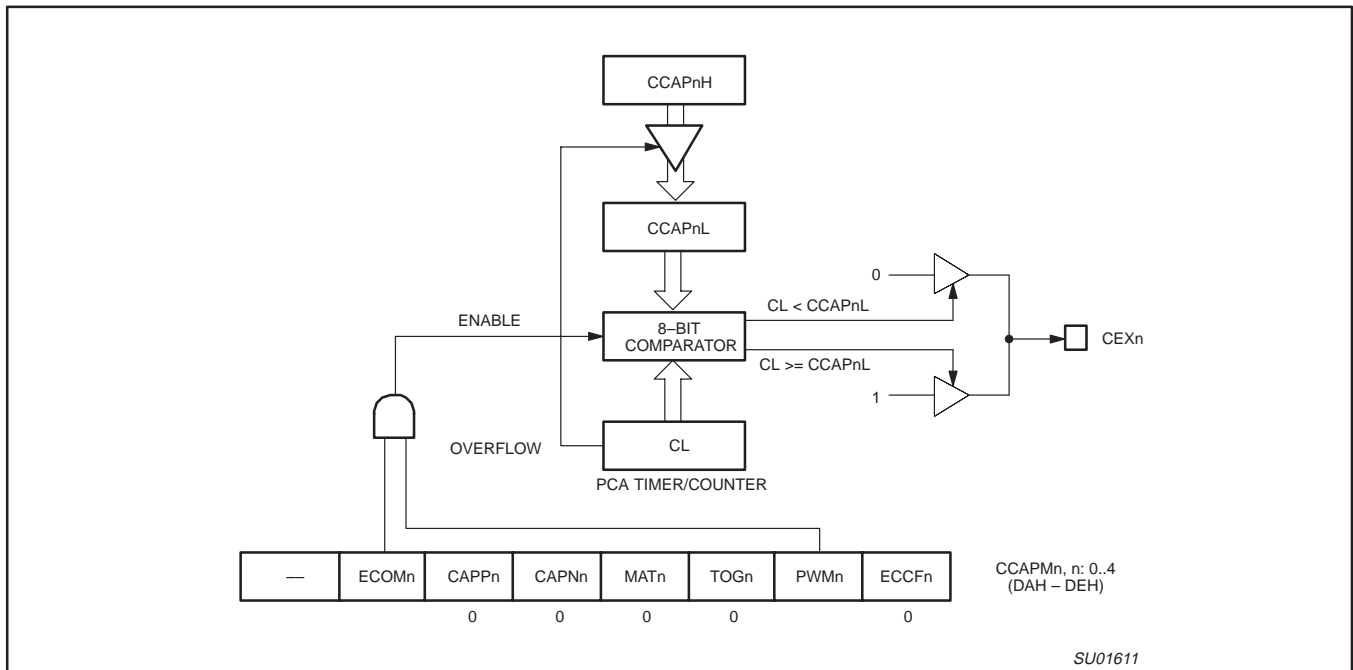

Figure 45. PCA PWM Mode

80C51 8-bit microcontroller family 16 KB OTP/ROM, 512B RAM, low voltage (2.7 to 5.5 V), low power, high speed (30/33 MHz), two 400KB I²C interfaces

P8xC660X2/661X2

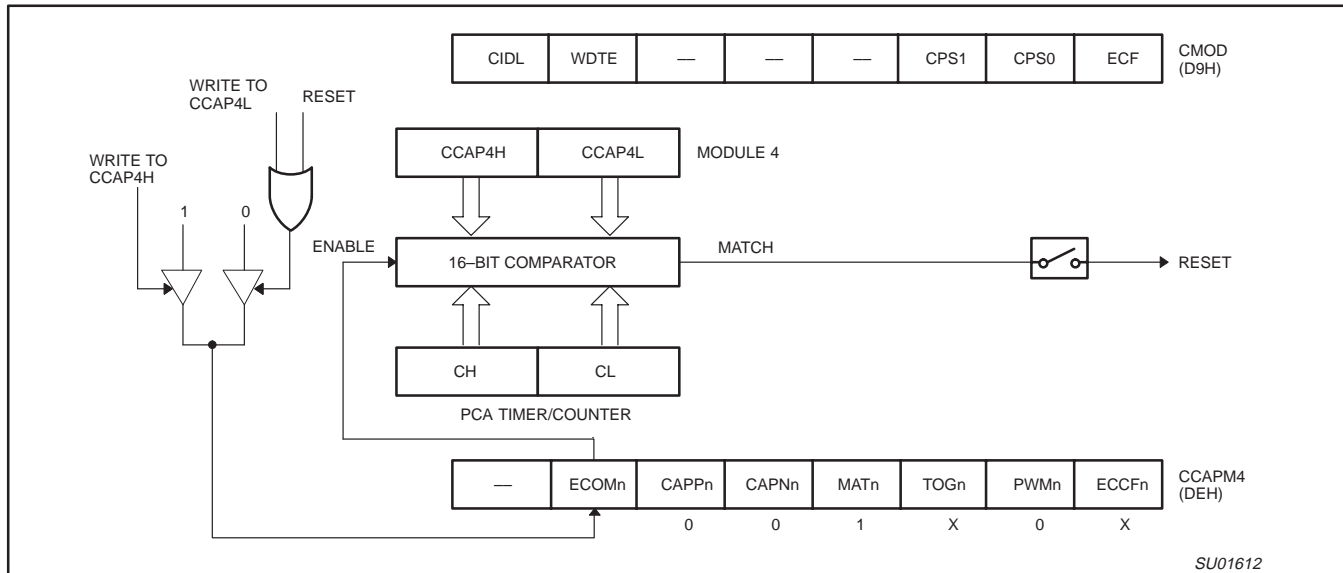

Figure 46. PCA Watchdog Timer mode (Module 4 only)

PCA Watchdog Timer

An on-board watchdog timer is available with the PCA to improve the reliability of the system without increasing chip count. Watchdog timers are useful for systems that are susceptible to noise, power glitches, or electrostatic discharge. Module 4 is the only PCA module that can be programmed as a watchdog. However, this module can still be used for other modes if the watchdog is not needed.

Figure 46 shows a diagram of how the watchdog works. The user pre-loads a 16-bit value in the compare registers. Just like the other compare modes, this 16-bit value is compared to the PCA timer value. If a match is allowed to occur, an internal reset will be generated. This will not cause the RST pin to be driven HIGH.

In order to hold off the reset, the user has three options:

1. periodically change the compare value so it will never match the PCA timer,
2. periodically change the PCA timer value so it will never match the compare values, or
3. disable the watchdog by clearing the WDTE bit before a match occurs and then re-enable it.

The first two options are more reliable because the watchdog timer is never disabled as in option #3. If the program counter ever goes astray, a match will eventually occur and cause an internal reset. The second option is also not recommended if other PCA modules are being used. Remember, the PCA timer is the time base for **all** modules; changing the time base for other modules would not be a good idea. Thus, in most applications the first solution is the best option.

Figure 47 shows the code for initializing the watchdog timer. Module 4 can be configured in either compare mode, and the WDTE bit in CMOD must also be set. The user's software then must periodically change (CCAP4H,CCAP4L) to keep a match from occurring with the PCA timer (CH,CL). This code is given in the WATCHDOG routine in Figure 47.

This routine should not be part of an interrupt service routine, because if the program counter goes astray and gets stuck in an infinite loop, interrupts will still be serviced and the watchdog will keep getting reset. Thus, the purpose of the watchdog would be defeated. Instead, call this subroutine from the main program within 2¹⁶ count of the PCA timer.

80C51 8-bit microcontroller family 16 KB OTP/ROM, 512B
RAM, low voltage (2.7 to 5.5 V), low power, high speed (30/33
MHz), two 400KB I²C interfaces

P8xC660X2/661X2

```
INIT_WATCHDOG:
    MOV CCAPM4, #4CH          ; Module 4 in compare mode
    MOV CCAP4L, #0FFH        ; Write to LOW byte first
    MOV CCAP4H, #0FFH        ; Before PCA timer counts up to
                                ; FFFF Hex, these compare values
                                ; must be changed
    ORL CMOD, #40H           ; Set the WDTE bit to enable the
                                ; watchdog timer without changing
                                ; the other bits in CMOD
;
;*****
;
; Main program goes here, but CALL WATCHDOG periodically.
;
;*****
;
WATCHDOG:
    CLR EA                   ; Hold off interrupts
    MOV CCAP4L, #00          ; Next compare value is within
    MOV CCAP4H, CH           ; 255 counts of the current PCA
    SETB EA                   ; timer value
    RET
```

Figure 47. PCA Watchdog Timer Initialization Code

80C51 8-bit microcontroller family 16 KB OTP/ROM, 512B RAM, low voltage (2.7 to 5.5 V), low power, high speed (30/33 MHz), two 400KB I²C interfaces

P8xC660X2/661X2

Expanded Data RAM Addressing

The P8xC660X2/661X2 has internal data memory that is mapped into four separate segments: the lower 128 bytes of RAM, upper 128 bytes of RAM, 128 bytes Special Function Register (SFR), and 256 bytes expanded RAM (ERAM) (768 bytes for the RD2).

The four segments are:

1. The Lower 128 bytes of RAM (addresses 00H to 7FH) are directly and indirectly addressable.
2. The Upper 128 bytes of RAM (addresses 80H to FFH) are indirectly addressable only.
3. The Special Function Registers, SFRs, (addresses 80H to FFH) are directly addressable only.
4. The 256/768-bytes expanded RAM (ERAM, 00H – 1FFH/2FFH) are indirectly accessed by move external instruction, MOVX, and with the EXTRAM bit cleared, see Figure 48.

The Lower 128 bytes can be accessed by either direct or indirect addressing. The Upper 128 bytes can be accessed by indirect addressing only. The Upper 128 bytes occupy the same address space as the SFR. That means they have the same address, but are physically separate from SFR space.

When an instruction accesses an internal location above address 7FH, the CPU knows whether the access is to the upper 128 bytes of data RAM or to SFR space by the addressing mode used in the instruction. Instructions that use direct addressing access SFR space. For example:

```
MOV 0A0H,#data
```

accesses the SFR at location 0A0H (which is P2). Instructions that use indirect addressing access the Upper 128 bytes of data RAM.

For example:

```
MOV @R0,acc
```

where R0 contains 0A0H, accesses the data byte at address 0A0H, rather than P2 (whose address is 0A0H).

The ERAM can be accessed by indirect addressing, with EXTRAM bit cleared and MOVX instructions. This part of memory is physically located on-chip, logically occupies the first 256/768 bytes of external data memory in the P8xC660X2/661X2.

With EXTRAM = 0, the ERAM is indirectly addressed, using the MOVX instruction in combination with any of the registers R0, R1 of the selected bank or DPTR. An access to ERAM will not affect ports P0, P3.6 (WR#) and P3.7 (RD#). P2 SFR is output during external addressing. For example, with EXTRAM = 0,

```
MOVX @R0,acc
```

where R0 contains 0A0H, accesses the ERAM at address 0A0H rather than external memory. An access to external data memory locations higher than the ERAM will be performed with the MOVX DPTR instructions in the same way as in the standard 80C51, so with P0 and P2 as data/address bus, and P3.6 and P3.7 as write and read timing signals. Refer to Figure 49.

With EXTRAM = 1, MOVX @Ri and MOVX @DPTR will be similar to the standard 80C51. MOVX @ Ri will provide an 8-bit address multiplexed with data on Port 0 and any output port pins can be used to output higher order address bits. This is to provide the external paging capability. MOVX @DPTR will generate a 16-bit address. Port 2 outputs the high-order eight address bits (the contents of DPH) while Port 0 multiplexes the low-order eight address bits (DPL) with data. MOVX @Ri and MOVX @DPTR will generate either read or write signals on P3.6 (WR) and P3.7 (RD).

The stack pointer (SP) may be located anywhere in the 256 bytes RAM (lower and upper RAM) internal data memory. The stack may not be located in the ERAM.

80C51 8-bit microcontroller family 16 KB OTP/ROM, 512B RAM, low voltage (2.7 to 5.5 V), low power, high speed (30/33 MHz), two 400KB I²C interfaces

P8xC660X2/661X2

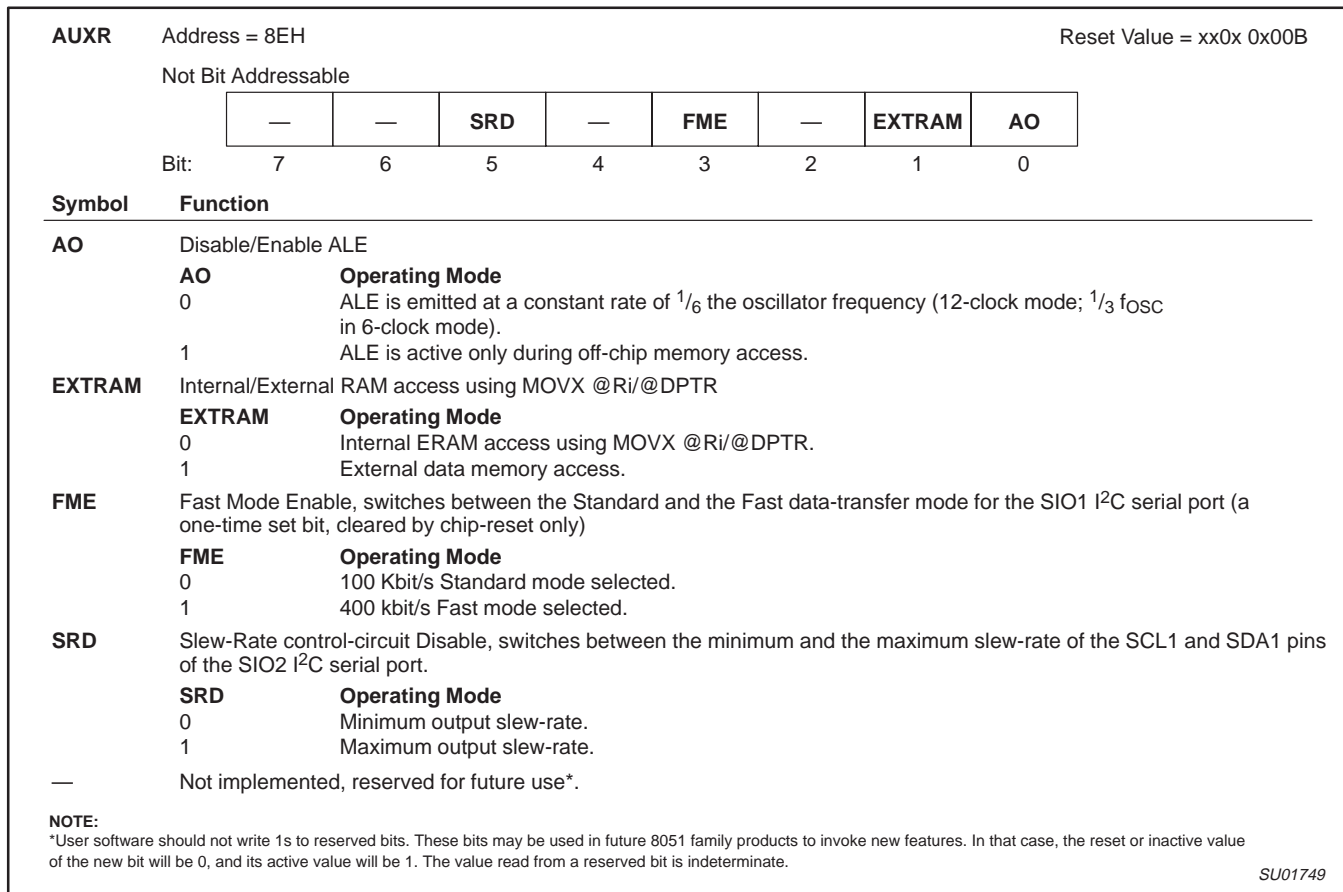

Figure 48. AUXR: Auxiliary Register

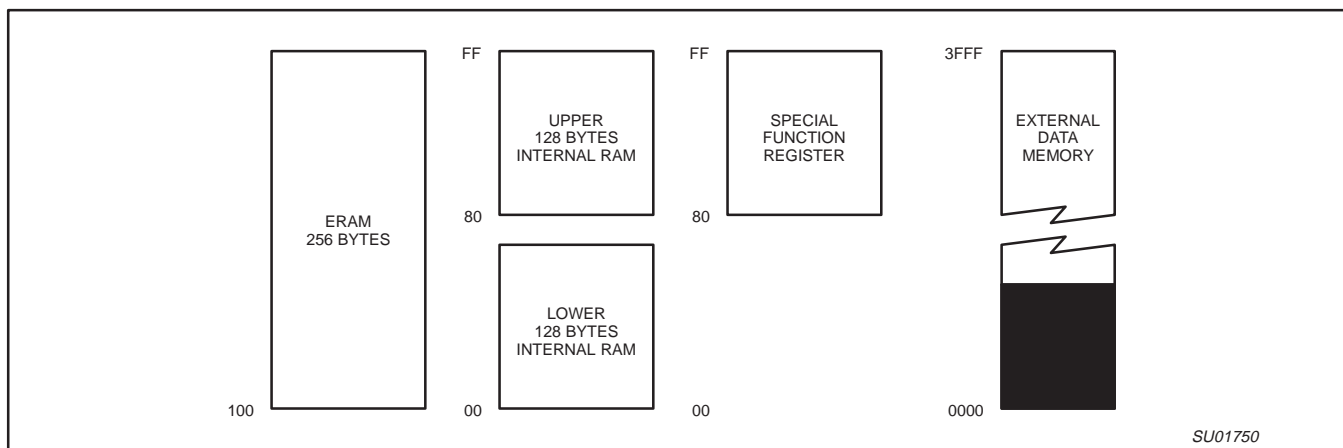

Figure 49. Internal and External Data Memory Address Space with EXTRAM = 0

80C51 8-bit microcontroller family 16 KB OTP/ROM, 512B RAM, low voltage (2.7 to 5.5 V), low power, high speed (30/33 MHz), two 400KB I²C interfaces

P8xC660X2/661X2

HARDWARE WATCHDOG TIMER (ONE-TIME ENABLED WITH RESET-OUT FOR P8XC66xX2)

The WDT is intended as a recovery method in situations where the CPU may be subjected to software upset. The WDT consists of a 14-bit counter and the WatchDog Timer reset (WDTRST) SFR. The WDT is disabled at reset. To enable the WDT, the user must write 01EH and 0E1H in sequence to the WDTRST, SFR location 0A6H. When the WDT is enabled, it will increment every machine cycle while the oscillator is running and there is no way to disable the WDT except through reset (either hardware reset or WDT overflow reset). When the WDT overflows, it will drive an output reset HIGH pulse at the RST-pin (see the note below).

Using the WDT

To enable the WDT, the user must write 01EH and 0E1H in sequence to the WDTRST, SFR location 0A6H. When the WDT is enabled, the user needs to service it by writing 01EH and 0E1H to WDTRST to avoid a WDT overflow. The 14-bit counter overflows when it reaches 16383 (3FFFH) and this will reset the device. When the WDT is enabled, it will increment every machine cycle while the oscillator is running. This means the user must reset the WDT at least every 16383 machine cycles. To reset the WDT, the user must write 01EH and 0E1H to WDTRST. WDTRST is a write only register. The WDT counter cannot be read or written. When the WDT overflows, it will generate an output RESET pulse at the reset pin (see note below). The RESET pulse duration is $98 \times T_{OSC}$ (6-clock mode; 196 in 12-clock mode), where $T_{OSC} = 1/f_{OSC}$. To make the best use of the WDT, it should be serviced in those sections of code that will periodically be executed within the time required to prevent a WDT reset.

80C51 8-bit microcontroller family 16 KB OTP/ROM, 512B RAM, low voltage (2.7 to 5.5 V), low power, high speed (30/33 MHz), two 400KB I²C interfaces

P8xC660X2/661X2

ABSOLUTE MAXIMUM RATINGS^{1, 2, 3}

| PARAMETER | RATING | UNIT |
|--|------------------------|------|
| Operating temperature under bias | 0 to +70 or -40 to +85 | °C |
| Storage temperature range | -65 to +150 | °C |
| Voltage on \overline{EA}/V_{PP} pin to V_{SS} | 0 to +13.0 | V |
| Voltage on any other pin to V_{SS} ⁴ | -0.5 to +6.0 | V |
| Maximum I_{OL} per I/O pin | 15 | mA |
| Power dissipation (based on package heat transfer limitations, not device power consumption) | 1.5 | W |

NOTES:

- Stresses above those listed under Absolute Maximum Ratings may cause permanent damage to the device. This is a stress rating only and functional operation of the device at these or any conditions other than those described in the AC and DC Electrical Characteristics section of this specification is not implied.
- This product includes circuitry specifically designed for the protection of its internal devices from the damaging effects of excessive static charge. Nonetheless, it is suggested that conventional precautions be taken to avoid applying greater than the rated maximum.
- Parameters are valid over operating temperature range unless otherwise specified. All voltages are with respect to V_{SS} unless otherwise noted.
- Transient voltage only.

AC ELECTRICAL CHARACTERISTICS

$T_{amb} = 0^{\circ}\text{C}$ to $+70^{\circ}\text{C}$ or -40°C to $+85^{\circ}\text{C}$

| SYMBOL | FIGURE | PARAMETER | OPERATING MODE | POWER SUPPLY VOLTAGE | CLOCK FREQUENCY RANGE | | UNIT |
|--------------|--------|----------------------|----------------|----------------------|-----------------------|-----|------|
| | | | | | MIN | MAX | |
| $1/t_{CLCL}$ | 55 | Oscillator frequency | 6-clock | 5 V \pm 10% | 0 | 30 | MHz |
| | | | 6-clock | 2.7 V to 5.5 V | 0 | 16 | MHz |
| | | | 12-clock | 5 V \pm 10% | 0 | 33 | MHz |
| | | | 12-clock | 2.7 V to 5.5 V | 0 | 16 | MHz |

80C51 8-bit microcontroller family 16 KB OTP/ROM, 512B RAM, low voltage (2.7 to 5.5 V), low power, high speed (30/33 MHz), two 400KB I²C interfaces

P8xC660X2/661X2

DC ELECTRICAL CHARACTERISTICS

T_{amb} = 0 °C to +70 °C or –40 °C to +85 °C; V_{CC} = 2.7 V to 5.5 V; V_{SS} = 0 V (16 MHz max. CPU clock)

| SYMBOL | PARAMETER | TEST CONDITIONS | LIMITS | | | UNIT |
|------------------|--|---|----------------------------------|------------------|---------------------------|------|
| | | | MIN | TYP ¹ | MAX | |
| V _{IL} | Input LOW voltage ¹¹ (except \overline{EA} , SCL, SDA) | 4.0 V < V _{CC} < 5.5 V | –0.5 | | 0.2 V _{CC} –0.1 | V |
| | | 2.7 V < V _{CC} < 4.0 V | –0.5 | | 0.7 V _{CC} | V |
| V _{IL1} | LOW level input voltage \overline{EA} | | –0.5 | | 0.2 V _{DD} –0.35 | V |
| V _{IH} | Input HIGH voltage (ports 0, 1, 2, 3, \overline{EA}) | | 0.2 V _{CC} +0.9 | | V _{CC} +0.5 | V |
| V _{IH1} | Input HIGH voltage, XTAL1, RST ¹¹ | | 0.7 V _{CC} | | V _{CC} +0.5 | V |
| V _{IH2} | Input HIGH voltage, SDL and SDA ¹³ | | 0.7 V _{DD} | | 5.5 | V |
| V _{OL} | Output LOW voltage, ports 1, 2 ⁸ | V _{CC} = 2.7 V; I _{OL} = 1.6 mA ² | – | | 0.4 | V |
| V _{OL1} | Output LOW voltage, port 0, ALE, PSEN ^{7,8} | V _{CC} = 2.7 V; I _{OL} = 3.2 mA ² | – | | 0.4 | V |
| V _{OH} | Output HIGH voltage, ports 1, 2, 3 ³ | V _{CC} = 2.7 V; I _{OH} = –20 μA | V _{CC} – 0.7 | | – | V |
| | | V _{CC} = 4.5 V; I _{OH} = –30 μA | V _{CC} – 0.7 | | – | V |
| V _{OH1} | Output HIGH voltage (port 0 in external bus mode), ALE ⁹ , PSEN ³ | V _{CC} = 2.7 V; I _{OH} = –3.2 mA | V _{CC} – 0.7 | | – | V |
| V _{HYS} | Hysteresis of Schmitt Trigger inputs SCL and SDA (Fast Mode) | | 0.5V _{DD} ¹⁴ | | – | V |
| I _{IL} | Logical 0 input current, ports 1, 2, 3 | V _{IN} = 0.4 V | –1 | | –50 | μA |
| I _{TL} | Logical 1-to-0 transition current, ports 1, 2, 3 ⁶ | V _{IN} = 2.0 V; See note 4 | – | | –650 | μA |
| I _{LI} | Input leakage current, port 0 | 0.45 < V _{IN} < V _{CC} – 0.3 | – | | ±10 | μA |
| I _{LI2} | Input leakage current SCL and SDA | 0 V < V _{IN} < 5.5 V | – | | ±10 | μA |
| | | 0 V < V _{DD} < 5.5 V | – | | ±10 | μA |
| I _{CC} | Power supply current (see Figure 58 and Source Code): Active mode @ 16 MHz Idle mode @ 16 MHz Power-down mode or clock stopped (see Figure 54 for conditions) ¹² | T _{amb} = 0 °C to 70 °C T _{amb} = –40 °C to +85 °C | | 2 | 30 | μA |
| | | | | | | μA |
| | | | | | | μA |
| | | | | | | μA |
| V _{RAM} | RAM keep-alive voltage | | 1.2 | | | V |
| R _{RST} | Internal reset pull-down resistor | | 40 | | 225 | kΩ |
| C _{IO} | Pin capacitance ¹⁰ (except \overline{EA}) | | – | | 15 | pF |

NOTES:

- Typical ratings are not guaranteed. Values listed are based on tests conducted on limited number of samples at room temperature.
- Capacitive loading on ports 0 and 2 may cause spurious noise to be superimposed on the V_{OL}s of ALE and ports 1 and 3. The noise is due to external bus capacitance discharging into the port 0 and port 2 pins when these pins make 1-to-0 transitions during bus operations. In the worst cases (capacitive loading > 100 pF), the noise pulse on the ALE pin may exceed 0.8 V. In such cases, it may be desirable to qualify ALE with a Schmitt Trigger, or use an address latch with a Schmitt Trigger STROBE input. I_{OL} can exceed these conditions provided that no single output sinks more than 5 mA and no more than two outputs exceed the test conditions.
- Capacitive loading on ports 0 and 2 may cause the V_{OH} on ALE and PSEN to momentarily fall below the V_{CC}–0.7 specification when the address bits are stabilizing.
- Pins of ports 1, 2 and 3 source a transition current when they are being externally driven from 1 to 0. The transition current reaches its maximum value when V_{IN} is approximately 2 V.
- See Figures 60 through 63 for I_{CC} test conditions and Figure 58 for I_{CC} vs. Frequency
12-clock mode characteristics:
Active mode (operating): I_{CC} = 1.0 mA + 1.1 mA × FREQ.[MHz]
Active mode (reset): I_{CC} = 7.0 mA + 1.1 mA × FREQ.[MHz]
Idle mode: I_{CC} = 1.0 mA + 0.44 mA × FREQ.[MHz]
- This value applies to T_{amb} = 0 °C to +70 °C. For T_{amb} = –40 °C to +85 °C, I_{TL} = –750 μA.
- Load capacitance for port 0, ALE, and PSEN = 100 pF, load capacitance for all other outputs = 80 pF.
- Under steady state (non-transient) conditions, I_{OL} must be externally limited as follows:
Maximum I_{OL} per port pin: 15 mA (*NOTE: This is 85 °C specification.)
Maximum I_{OL} per 8-bit port: 26 mA
Maximum total I_{OL} for all outputs: 71 mA
If I_{OL} exceeds the test condition, V_{OL} may exceed the related specification. Pins are not guaranteed to sink current greater than the listed test conditions.
- ALE is tested to V_{OH1}, except when ALE is off then V_{OH} is the voltage specification.

80C51 8-bit microcontroller family 16 KB OTP/ROM, 512B
RAM, low voltage (2.7 to 5.5 V), low power, high speed (30/33
MHz), two 400KB I²C interfaces

P8xC660X2/661X2

10. Pin capacitance is characterized but not tested. Pin capacitance is less than 25 pF. Pin capacitance of ceramic package is less than 15 pF (except \overline{EA} is 25 pF).
11. To improve noise rejection a nominal 100 ns glitch rejection circuitry has been added to the RST pin, and a nominal 15 ns glitch rejection circuitry has been added to the $\overline{INT0}$ and $\overline{INT1}$ pins. Previous devices provided only an inherent 5 ns of glitch rejection.
12. Power down mode for 3 V range: Commercial Temperature Range – typ: 0.5 μ A, max. 20 μ A; Industrial Temperature Range – typ. 1.0 μ A, max. 30 μ A;
13. The input threshold voltage of SCL and SDA (SIO1) meets the I²C specification, so an input voltage below 0.3 V_{DD} will be recognized as a logic 0 while an input voltage above 0.7 V_{DD} will be recognized as a logic 1.
14. Not 100% tested.

80C51 8-bit microcontroller family 16 KB OTP/ROM, 512B RAM, low voltage (2.7 to 5.5 V), low power, high speed (30/33 MHz), two 400KB I²C interfaces

P8xC660X2/661X2

DC ELECTRICAL CHARACTERISTICS

T_{amb} = 0 °C to +70 °C or -40 °C to +85 °C; V_{CC} = 5 V ±10%; V_{SS} = 0 V (30/33 MHz max. CPU clock)

| SYMBOL | PARAMETER | TEST CONDITIONS | LIMITS | | | UNIT |
|------------------|---|---|--------------------------|------------------|---------------------------|--------------------|
| | | | MIN | TYP ¹ | MAX | |
| V _{IL} | Input LOW voltage ¹¹ (except $\bar{E}A$, SCL, SDA) | 4.5 V < V _{CC} < 5.5 V | -0.5 | | 0.2 V _{CC} -0.1 | V |
| V _{IL1} | LOW level input voltage $\bar{E}A$ | | -0.5 | | 0.2 V _{DD} -0.35 | V |
| V _{IH} | Input HIGH voltage (ports 0, 1, 2, 3, $\bar{E}A$) | | 0.2 V _{CC} +0.9 | | V _{CC} +0.5 | V |
| V _{IH1} | Input HIGH voltage, XTAL1, RST ¹¹ | | 0.7 V _{CC} | | V _{CC} +0.5 | V |
| V _{IH2} | Input HIGH voltage, SDL and SDA ¹² | | 0.7 V _{DD} | | 5.5 | V |
| V _{OL} | Output LOW voltage, ports 1, 2, 3 ⁸ | V _{CC} = 4.5 V; I _{OL} = 1.6 mA ² | - | | 0.4 | V |
| V _{OL1} | Output LOW voltage, port 0, ALE, \bar{PSEN} ^{7, 8} | V _{CC} = 4.5 V; I _{OL} = 3.2 mA ² | - | | 0.4 | V |
| V _{OH} | Output HIGH voltage, ports 1, 2, 3 ³ | V _{CC} = 4.5 V; I _{OH} = -30 μ A | V _{CC} - 0.7 | | - | V |
| V _{OH1} | Output HIGH voltage (port 0 in external bus mode), ALE ⁹ , \bar{PSEN} ³ | V _{CC} = 4.5 V; I _{OH} = -3.2 mA | V _{CC} - 0.7 | | - | V |
| V _{HYS} | Hysteresis of Schmitt Trigger inputs SCL and SDA (Fast Mode) ¹³ | | 0.5V _{DD} | | - | V |
| I _{IL} | Logical 0 input current, ports 1, 2, 3 | V _{IN} = 0.4 V | -1 | | -50 | μ A |
| I _{TL} | Logical 1-to-0 transition current, ports 1, 2, 3 ⁶ | V _{IN} = 2.0 V; See note 4 | - | | -650 | μ A |
| I _{LI} | Input leakage current, port 0 | 0.45 < V _{IN} < V _{CC} - 0.3 | - | | ±10 | μ A |
| I _{LI2} | Input leakage current SCL and SDA | 0 V < V _{IN} < 5.5 V 0 V < V _{DD} < 5.5 V | - | | ±10 | μ A |
| I _{CC} | Power supply current Active mode (see Note 5) Idle mode (see Note 5) Power-down mode or clock stopped (see Figure 63 for conditions) | T _{amb} = 0 °C to 70 °C T _{amb} = -40 °C to +85 °C | | 2 3 | 30 50 | μ A μ A |
| V _{RAM} | RAM keep-alive voltage | | 1.2 | | | V |
| R _{RST} | Internal reset pull-down resistor | | 40 | | 225 | k Ω |
| C _{IO} | Pin capacitance ¹⁰ (except $\bar{E}A$) | | - | | 15 | pF |

NOTES:

- Typical ratings are not guaranteed. The values listed are at room temperature, 5 V.
- Capacitive loading on ports 0 and 2 may cause spurious noise to be superimposed on the V_{OL}s of ALE and ports 1 and 3. The noise is due to external bus capacitance discharging into the port 0 and port 2 pins when these pins make 1-to-0 transitions during bus operations. In the worst cases (capacitive loading > 100 pF), the noise pulse on the ALE pin may exceed 0.8 V. In such cases, it may be desirable to qualify ALE with a Schmitt Trigger, or use an address latch with a Schmitt Trigger STROBE input. I_{OL} can exceed these conditions provided that no single output sinks more than 5 mA and no more than two outputs exceed the test conditions.
- Capacitive loading on ports 0 and 2 may cause the V_{OH} on ALE and \bar{PSEN} to momentarily fall below the V_{CC}-0.7 specification when the address bits are stabilizing.
- Pins of ports 1, 2 and 3 source a transition current when they are being externally driven from 1 to 0. The transition current reaches its maximum value when V_{IN} is approximately 2 V.
- See Figures 60 through 63 for I_{CC} test conditions and Figure 58 for I_{CC} vs. Frequency.
12-clock mode characteristics:
Active mode (operating): I_{CC} = 1.0 mA + 1.1 mA × FREQ.[MHz]
Active mode (reset): I_{CC} = 7.0 mA + 1.1 mA × FREQ.[MHz]
Idle mode: I_{CC} = 1.0 mA + 0.44 mA × FREQ.[MHz]
- This value applies to T_{amb} = 0 °C to +70 °C. For T_{amb} = -40 °C to +85 °C, I_{TL} = -750 μ A.
- Load capacitance for port 0, ALE, and \bar{PSEN} = 100 pF, load capacitance for all other outputs = 80 pF.
- Under steady state (non-transient) conditions, I_{OL} must be externally limited as follows:
Maximum I_{OL} per port pin: 15 mA (*NOTE: This is 85 °C specification.)
Maximum I_{OL} per 8-bit port: 26 mA
Maximum total I_{OL} for all outputs: 71 mA
If I_{OL} exceeds the test condition, V_{OL} may exceed the related specification. Pins are not guaranteed to sink current greater than the listed test conditions.
- ALE is tested to V_{OH1}, except when ALE is off then V_{OH} is the voltage specification.
- Pin capacitance is characterized but not tested. Pin capacitance is less than 25 pF. Pin capacitance of ceramic package is less than 15 pF (except $\bar{E}A$ is 25 pF).
- To improve noise rejection a nominal 100 ns glitch rejection circuitry has been added to the RST pin, and a nominal 15 ns glitch rejection circuitry has been added to the INT0 and INT1 pins. Previous devices provided only an inherent 5 ns of glitch rejection.

80C51 8-bit microcontroller family 16 KB OTP/ROM, 512B
RAM, low voltage (2.7 to 5.5 V), low power, high speed (30/33
MHz), two 400KB I²C interfaces

P8xC660X2/661X2

12. The input threshold voltage of SCL and SDA (SIO1) meets the I²C specification, so an input voltage below 0.3 V_{DD} will be recognized as a logic 0 while an input voltage above 0.7 V_{DD} will be recognized as a logic 1.
13. Not 100% tested.

80C51 8-bit microcontroller family 16 KB OTP/ROM, 512B RAM, low voltage (2.7 to 5.5 V), low power, high speed (30/33 MHz), two 400KB I²C interfaces

P8xC660X2/661X2

AC ELECTRICAL CHARACTERISTICS (12-CLOCK MODE, 5 V ±10% OPERATION)

T_{amb} = 0 °C to +70 °C or -40 °C to +85 °C ; V_{CC} = 5 V ±10%, V_{SS} = 0 V^{1,2,3,4}

| Symbol | Figure | Parameter | Limits | | 16 MHz Clock | | Unit |
|-----------------------|--------|--|--------------------------|---------------------------------------|--------------|-------|------|
| | | | MIN | MAX | MIN | MAX | |
| 1/t _{CLCL} | 55 | Oscillator frequency | 0 | 33 | | | MHz |
| t _{LHLL} | 50 | ALE pulse width | 2 t _{CLCL} -8 | | 117 | | ns |
| t _{AVLL} | 50 | Address valid to ALE LOW | t _{CLCL} -13 | | 49.5 | | ns |
| t _{LLAX} | 50 | Address hold after ALE LOW | t _{CLCL} -20 | | 42.5 | | ns |
| t _{LLIV} | 50 | ALE LOW to valid instruction in | | 4 t _{CLCL} -35 | | 215 | ns |
| t _{LLPL} | 50 | ALE LOW to PSEN LOW | t _{CLCL} -10 | | 52.5 | | ns |
| t _{PLPH} | 50 | PSEN pulse width | 3 t _{CLCL} -10 | | 177.5 | | ns |
| t _{PLIV} | 50 | PSEN LOW to valid instruction in | | 3 t _{CLCL} -35 | | 152.5 | ns |
| t _{PXIX} | 50 | Input instruction hold after PSEN | 0 | | 0 | | ns |
| t _{PXIZ} | 50 | Input instruction float after PSEN | | t _{CLCL} -10 | | 52.5 | ns |
| t _{AVIV} | 50 | Address to valid instruction in | | 5 t _{CLCL} -35 | | 277.5 | ns |
| t _{PLAZ} | 50 | PSEN LOW to address float | | 10 | | 10 | ns |
| Data Memory | | | | | | | |
| t _{RLRH} | 51 | RD pulse width | 6 t _{CLCL} -20 | | 355 | | ns |
| t _{WLWH} | 52 | WR pulse width | 6 t _{CLCL} -20 | | 355 | | ns |
| t _{RLDV} | 51 | RD LOW to valid data in | | 5 t _{CLCL} -35 | | 277.5 | ns |
| t _{RHDX} | 51 | Data hold after RD | 0 | | 0 | | ns |
| t _{RHDZ} | 51 | Data float after RD | | 2 t _{CLCL} -10 | | 115 | ns |
| t _{LLDV} | 51 | ALE LOW to valid data in | | 8 t _{CLCL} -35 | | 465 | ns |
| t _{AVDV} | 51 | Address to valid data in | | 9 t _{CLCL} -35 | | 527.5 | ns |
| t _{LLWL} | 51, 52 | ALE LOW to RD or WR LOW | 3 t _{CLCL} -15 | 3 t _{CLCL} +15 | 172.5 | 202.5 | ns |
| t _{AVWL} | 51, 52 | Address valid to WR LOW or RD LOW | 4 t _{CLCL} -15 | | 235 | | ns |
| t _{QVWX} | 52 | Data valid to WR transition | t _{CLCL} -25 | | 37.5 | | ns |
| t _{WHQX} | 52 | Data hold after WR | t _{CLCL} -15 | | 47.5 | | ns |
| t _{QVWH} | 52 | Data valid to WR HIGH | 7 t _{CLCL} -5 | | 432.5 | | ns |
| t _{RLAZ} | 51 | RD LOW to address float | | 0 | | 0 | ns |
| t _{WHLH} | 51, 52 | RD or WR HIGH to ALE HIGH | t _{CLCL} -10 | t _{CLCL} +10 | 52.5 | 72.5 | ns |
| External Clock | | | | | | | |
| t _{CHCX} | 55 | High time | 0.32 t _{CLCL} | t _{CLCL} - t _{CLCX} | | | ns |
| t _{CLCX} | 55 | Low time | 0.32 t _{CLCL} | t _{CLCL} - t _{CHCX} | | | ns |
| t _{CLCH} | 55 | Rise time | | 5 | | | ns |
| t _{CHCL} | 55 | Fall time | | 5 | | | ns |
| Shift register | | | | | | | |
| t _{XLXL} | 54 | Serial port clock cycle time | 12 t _{CLCL} | | 750 | | ns |
| t _{QVXH} | 54 | Output data setup to clock rising edge | 10 t _{CLCL} -25 | | 600 | | ns |
| t _{XHQX} | 54 | Output data hold after clock rising edge | 2 t _{CLCL} -15 | | 110 | | ns |
| t _{XHDX} | 54 | Input data hold after clock rising edge | 0 | | 0 | | ns |
| t _{XHDV} | 54 | Clock rising edge to input data valid ⁵ | | 10 t _{CLCL} -133 | | 492 | ns |

NOTES:

- Parameters are valid over operating temperature range unless otherwise specified.
- Load capacitance for port 0, ALE, and PSEN = 100 pF, load capacitance for all outputs = 80 pF
- Interfacing the microcontroller to devices with float time up to 45 ns is permitted. This limited bus contention will not cause damage to port 0 drivers.
- Parts are guaranteed by design to operate down to 0 Hz.
- Below 16 MHz this parameter is 8 t_{CLCL} - 133.

80C51 8-bit microcontroller family 16 KB OTP/ROM, 512B RAM, low voltage (2.7 to 5.5 V), low power, high speed (30/33 MHz), two 400KB I²C interfaces

P8xC660X2/661X2

AC ELECTRICAL CHARACTERISTICS (12-CLOCK MODE, 2.7 V TO 5.5 V OPERATION)

T_{amb} = 0 °C to +70 °C or -40 °C to +85 °C ; V_{CC} = 2.7 V to 5.5 V, V_{SS} = 0 V^{1,2,3,4}

| Symbol | Figure | Parameter | Limits | | 16 MHz Clock | | Unit |
|-----------------------|--------|--|--------------------------|---------------------------------------|--------------|-------|------|
| | | | MIN | MAX | MIN | MAX | |
| 1/t _{CLCL} | 55 | Oscillator frequency | 0 | 16 | | | MHz |
| t _{LHLL} | 50 | ALE pulse width | 2t _{CLCL} -10 | | 115 | | ns |
| t _{AVLL} | 50 | Address valid to ALE LOW | t _{CLCL} -15 | | 47.5 | | ns |
| t _{LLAX} | 50 | Address hold after ALE LOW | t _{CLCL} -25 | | 37.5 | | ns |
| t _{LLIV} | 50 | ALE LOW to valid instruction in | | 4 t _{CLCL} -55 | | 195 | ns |
| t _{LLPL} | 50 | ALE LOW to PSEN LOW | t _{CLCL} -15 | | 47.5 | | ns |
| t _{PLPH} | 50 | PSEN pulse width | 3 t _{CLCL} -15 | | 172.5 | | ns |
| t _{PLIV} | 50 | PSEN LOW to valid instruction in | | 3 t _{CLCL} -55 | | 132.5 | ns |
| t _{PXIX} | 50 | Input instruction hold after PSEN | 0 | | 0 | | ns |
| t _{PXIZ} | 50 | Input instruction float after PSEN | | t _{CLCL} -10 | | 52.5 | ns |
| t _{AVIV} | 50 | Address to valid instruction in | | 5 t _{CLCL} -50 | | 262.5 | ns |
| t _{PLAZ} | 50 | PSEN LOW to address float | | 10 | | 10 | ns |
| Data Memory | | | | | | | |
| t _{RLRH} | 51 | RD pulse width | 6 t _{CLCL} -25 | | 350 | | ns |
| t _{WLWH} | 52 | WR pulse width | 6 t _{CLCL} -25 | | 350 | | ns |
| t _{RLDV} | 51 | RD LOW to valid data in | | 5 t _{CLCL} -50 | | 262.5 | ns |
| t _{RHDX} | 51 | Data hold after RD | 0 | | 0 | | ns |
| t _{RHDZ} | 51 | Data float after RD | | 2 t _{CLCL} -20 | | 105 | ns |
| t _{LLDV} | 51 | ALE LOW to valid data in | | 8 t _{CLCL} -55 | | 445 | ns |
| t _{AVDV} | 51 | Address to valid data in | | 9 t _{CLCL} -50 | | 512.5 | ns |
| t _{LLWL} | 51, 52 | ALE LOW to RD or WR LOW | 3 t _{CLCL} -20 | 3 t _{CLCL} +20 | 167.5 | 207.5 | ns |
| t _{AVWL} | 51, 52 | Address valid to WR LOW or RD LOW | 4 t _{CLCL} -20 | | 230 | | ns |
| t _{QVWX} | 52 | Data valid to WR transition | t _{CLCL} -30 | | 32.5 | | ns |
| t _{WHQX} | 52 | Data hold after WR | t _{CLCL} -20 | | 42.5 | | ns |
| t _{QVWH} | 52 | Data valid to WR HIGH | 7 t _{CLCL} -10 | | 427.5 | | ns |
| t _{RLAZ} | 51 | RD LOW to address float | | 0 | | 0 | ns |
| t _{WHLH} | 51, 52 | RD or WR HIGH to ALE HIGH | t _{CLCL} -15 | t _{CLCL} +15 | 47.5 | 77.5 | ns |
| External Clock | | | | | | | |
| t _{CHCX} | 55 | High time | 0.32 t _{CLCL} | t _{CLCL} - t _{CLCX} | | | ns |
| t _{CLCX} | 55 | Low time | 0.32 t _{CLCL} | t _{CLCL} - t _{CHCX} | | | ns |
| t _{CLCH} | 55 | Rise time | | 5 | | | ns |
| t _{CHCL} | 55 | Fall time | | 5 | | | ns |
| Shift register | | | | | | | |
| t _{XLXL} | 54 | Serial port clock cycle time | 12 t _{CLCL} | | 750 | | ns |
| t _{QVXH} | 54 | Output data setup to clock rising edge | 10 t _{CLCL} -25 | | 600 | | ns |
| t _{XHQX} | 54 | Output data hold after clock rising edge | 2 t _{CLCL} -15 | | 110 | | ns |
| t _{XHDX} | 54 | Input data hold after clock rising edge | 0 | | 0 | | ns |
| t _{XHDV} | 54 | Clock rising edge to input data valid ⁵ | | 10 t _{CLCL} -133 | | 492 | ns |

NOTES:

- Parameters are valid over operating temperature range unless otherwise specified.
- Load capacitance for port 0, ALE, and PSEN = 100 pF, load capacitance for all outputs = 80 pF
- Interfacing the microcontroller to devices with float time up to 45 ns is permitted. This limited bus contention will not cause damage to port 0 drivers.
- Parts are guaranteed by design to operate down to 0 Hz.
- Below 16 MHz this parameter is 8 t_{CLCL} - 133.

80C51 8-bit microcontroller family 16 KB OTP/ROM, 512B RAM, low voltage (2.7 to 5.5 V), low power, high speed (30/33 MHz), two 400KB I²C interfaces

P8xC660X2/661X2

AC ELECTRICAL CHARACTERISTICS (6-CLOCK MODE, 5 V ±10% OPERATION)

T_{amb} = 0 °C to +70 °C or -40 °C to +85 °C ; V_{CC} = 5 V ±10%, V_{SS} = 0 V^{1,2,3,4,5}

| Symbol | Figure | Parameter | Limits | | 16 MHz Clock | | Unit |
|-----------------------|--------|--|---------------------------|---------------------------------------|--------------|--------|------|
| | | | MIN | MAX | MIN | MAX | |
| 1/t _{CLCL} | 55 | Oscillator frequency | 0 | 30 | | | MHz |
| t _{LHLL} | 50 | ALE pulse width | t _{CLCL} -8 | | 54.5 | | ns |
| t _{AVLL} | 50 | Address valid to ALE LOW | 0.5 t _{CLCL} -13 | | 18.25 | | ns |
| t _{LLAX} | 50 | Address hold after ALE LOW | 0.5 t _{CLCL} -20 | | 11.25 | | ns |
| t _{LLIV} | 50 | ALE LOW to valid instruction in | | 2 t _{CLCL} -35 | | 90 | ns |
| t _{LLPL} | 50 | ALE LOW to PSEN LOW | 0.5 t _{CLCL} -10 | | 21.25 | | ns |
| t _{PLPH} | 50 | PSEN pulse width | 1.5 t _{CLCL} -10 | | 83.75 | | ns |
| t _{PLIV} | 50 | PSEN LOW to valid instruction in | | 1.5 t _{CLCL} -35 | | 58.75 | ns |
| t _{PXIX} | 50 | Input instruction hold after PSEN | 0 | | 0 | | ns |
| t _{PXIZ} | 50 | Input instruction float after PSEN | | 0.5 t _{CLCL} -10 | | 21.25 | ns |
| t _{AVIV} | 50 | Address to valid instruction in | | 2.5 t _{CLCL} -35 | | 121.25 | ns |
| t _{PLAZ} | 50 | PSEN LOW to address float | | 10 | | 10 | ns |
| Data Memory | | | | | | | |
| t _{RLRH} | 51 | RD pulse width | 3 t _{CLCL} -20 | | 167.5 | | ns |
| t _{WLWH} | 52 | WR pulse width | 3 t _{CLCL} -20 | | 167.5 | | ns |
| t _{RLDV} | 51 | RD LOW to valid data in | | 2.5 t _{CLCL} -35 | | 121.25 | ns |
| t _{RHDX} | 51 | Data hold after RD | 0 | | 0 | | ns |
| t _{RHDZ} | 51 | Data float after RD | | t _{CLCL} -10 | | 52.5 | ns |
| t _{LLDV} | 51 | ALE LOW to valid data in | | 4 t _{CLCL} -35 | | 215 | ns |
| t _{ADV} | 51 | Address to valid data in | | 4.5 t _{CLCL} -35 | | 246.25 | ns |
| t _{LLWL} | 51, 52 | ALE LOW to RD or WR LOW | 1.5 t _{CLCL} -15 | 1.5 t _{CLCL} +15 | 78.75 | 108.75 | ns |
| t _{AVWL} | 51, 52 | Address valid to WR LOW or RD LOW | 2 t _{CLCL} -15 | | 110 | | ns |
| t _{QVWX} | 52 | Data valid to WR transition | 0.5 t _{CLCL} -25 | | 6.25 | | ns |
| t _{WHQX} | 52 | Data hold after WR | 0.5 t _{CLCL} -15 | | 16.25 | | ns |
| t _{QVWH} | 52 | Data valid to WR HIGH | 3.5 t _{CLCL} -5 | | 213.75 | | ns |
| t _{RLAZ} | 51 | RD LOW to address float | | 0 | | 0 | ns |
| t _{WHLH} | 51, 52 | RD or WR HIGH to ALE HIGH | 0.5 t _{CLCL} -10 | 0.5 t _{CLCL} +10 | 21.25 | 41.25 | ns |
| External Clock | | | | | | | |
| t _{CHCX} | 55 | High time | 0.4 t _{CLCL} | t _{CLCL} - t _{CLCX} | | | ns |
| t _{CLCX} | 55 | Low time | 0.4 t _{CLCL} | t _{CLCL} - t _{CHCX} | | | ns |
| t _{CLCH} | 55 | Rise time | | 5 | | | ns |
| t _{CHCL} | 55 | Fall time | | 5 | | | ns |
| Shift register | | | | | | | |
| t _{XLXL} | 54 | Serial port clock cycle time | 6 t _{CLCL} | | 375 | | ns |
| t _{QVXH} | 54 | Output data setup to clock rising edge | 5 t _{CLCL} -25 | | 287.5 | | ns |
| t _{XHQX} | 54 | Output data hold after clock rising edge | t _{CLCL} -15 | | 47.5 | | ns |
| t _{XHDX} | 54 | Input data hold after clock rising edge | 0 | | 0 | | ns |
| t _{XHDV} | 54 | Clock rising edge to input data valid ⁶ | | 5 t _{CLCL} -133 | | 179.5 | ns |

NOTES:

- Parameters are valid over operating temperature range unless otherwise specified.
- Load capacitance for port 0, ALE, and PSEN=100 pF, load capacitance for all outputs = 80 pF
- Interfacing the microcontroller to devices with float time up to 45ns is permitted. This limited bus contention will not cause damage to port 0 drivers.
- Parts are guaranteed by design to operate down to 0 Hz.
- Data shown in the table are the best mathematical models for the set of measured values obtained in tests. If a particular parameter calculated at a customer specified frequency has a negative value, it should be considered equal to zero.
- Below 16 MHz this parameter is 4 t_{CLCL} - 133

80C51 8-bit microcontroller family 16 KB OTP/ROM, 512B RAM, low voltage (2.7 to 5.5 V), low power, high speed (30/33 MHz), two 400KB I²C interfaces

P8xC660X2/661X2

AC ELECTRICAL CHARACTERISTICS (6-CLOCK MODE, 2.7 V TO 5.5 V OPERATION)

T_{amb} = 0 °C to +70 °C or -40 °C to +85 °C ; V_{CC}=2.7 V to 5.5 V, V_{SS} = 0 V^{1,2,3,4,5}

| Symbol | Figure | Parameter | Limits | | 16 MHz Clock | | Unit |
|-----------------------|--------|--|---------------------------|---------------------------------------|--------------|--------|------|
| | | | MIN | MAX | MIN | MAX | |
| 1/t _{CLCL} | 55 | Oscillator frequency | 0 | 16 | | | MHz |
| t _{LHLL} | 50 | ALE pulse width | t _{CLCL} -10 | | 52.5 | | ns |
| t _{AVLL} | 50 | Address valid to ALE LOW | 0.5 t _{CLCL} -15 | | 16.25 | | ns |
| t _{LLAX} | 50 | Address hold after ALE LOW | 0.5 t _{CLCL} -25 | | 6.25 | | ns |
| t _{LLIV} | 50 | ALE LOW to valid instruction in | | 2 t _{CLCL} -55 | | 70 | ns |
| t _{LLPL} | 50 | ALE LOW to PSEN LOW | 0.5 t _{CLCL} -15 | | 16.25 | | ns |
| t _{PLPH} | 50 | PSEN pulse width | 1.5 t _{CLCL} -15 | | 78.75 | | ns |
| t _{PLIV} | 50 | PSEN LOW to valid instruction in | | 1.5 t _{CLCL} -55 | | 38.75 | ns |
| t _{PXIX} | 50 | Input instruction hold after PSEN | 0 | | 0 | | ns |
| t _{PXIZ} | 50 | Input instruction float after PSEN | | 0.5 t _{CLCL} -10 | | 21.25 | ns |
| t _{AVIV} | 50 | Address to valid instruction in | | 2.5 t _{CLCL} -50 | | 101.25 | ns |
| t _{PLAZ} | 50 | PSEN LOW to address float | | 10 | | 10 | ns |
| Data Memory | | | | | | | |
| t _{RLRH} | 51 | RD pulse width | 3 t _{CLCL} -25 | | 162.5 | | ns |
| t _{WLWH} | 52 | WR pulse width | 3 t _{CLCL} -25 | | 162.5 | | ns |
| t _{RLDV} | 51 | RD LOW to valid data in | | 2.5 t _{CLCL} -50 | | 106.25 | ns |
| t _{RHDX} | 51 | Data hold after RD | 0 | | 0 | | ns |
| t _{RHDZ} | 51 | Data float after RD | | t _{CLCL} -20 | | 42.5 | ns |
| t _{LLDV} | 51 | ALE LOW to valid data in | | 4 t _{CLCL} -55 | | 195 | ns |
| t _{AVDV} | 51 | Address to valid data in | | 4.5 t _{CLCL} -50 | | 231.25 | ns |
| t _{LLWL} | 51, 52 | ALE LOW to RD or WR LOW | 1.5 t _{CLCL} -20 | 1.5 t _{CLCL} +20 | 73.75 | 113.75 | ns |
| t _{AVWL} | 51, 52 | Address valid to WR LOW or RD LOW | 2 t _{CLCL} -20 | | 105 | | ns |
| t _{QVWX} | 52 | Data valid to WR transition | 0.5 t _{CLCL} -30 | | 1.25 | | ns |
| t _{WHQX} | 52 | Data hold after WR | 0.5 t _{CLCL} -20 | | 11.25 | | ns |
| t _{QVWH} | 52 | Data valid to WR HIGH | 3.5 t _{CLCL} -10 | | 208.75 | | ns |
| t _{RLAZ} | 51 | RD LOW to address float | | 0 | | 0 | ns |
| t _{WHLH} | 51, 52 | RD or WR HIGH to ALE HIGH | 0.5 t _{CLCL} -15 | 0.5 t _{CLCL} +15 | 16.25 | 46.25 | ns |
| External Clock | | | | | | | |
| t _{CHCX} | 55 | High time | 0.4 t _{CLCL} | t _{CLCL} - t _{CLCX} | | | ns |
| t _{CLCX} | 55 | Low time | 0.4 t _{CLCL} | t _{CLCL} - t _{CHCX} | | | ns |
| t _{CLCH} | 55 | Rise time | | 5 | | | ns |
| t _{CHCL} | 55 | Fall time | | 5 | | | ns |
| Shift register | | | | | | | |
| t _{XLXL} | 54 | Serial port clock cycle time | 6 t _{CLCL} | | 375 | | ns |
| t _{QVXH} | 54 | Output data setup to clock rising edge | 5 t _{CLCL} -25 | | 287.5 | | ns |
| t _{XHQX} | 54 | Output data hold after clock rising edge | t _{CLCL} -15 | | 47.5 | | ns |
| t _{XHDX} | 54 | Input data hold after clock rising edge | 0 | | 0 | | ns |
| t _{XHDV} | 54 | Clock rising edge to input data valid ⁶ | | 5 t _{CLCL} -133 | | 179.5 | ns |

NOTES:

- Parameters are valid over operating temperature range unless otherwise specified.
- Load capacitance for port 0, ALE, and PSEN=100 pF, load capacitance for all outputs = 80 pF
- Interfacing the microcontroller to devices with float time up to 45ns is permitted. This limited bus contention will not cause damage to port 0 drivers.
- Parts are guaranteed by design to operate down to 0 Hz.
- Data shown in the table are the best mathematical models for the set of measured values obtained in tests. If a particular parameter calculated at a customer specified frequency has a negative value, it should be considered equal to zero.
- Below 16 MHz this parameter is 4 t_{CLCL} - 133

80C51 8-bit microcontroller family 16 KB OTP/ROM, 512B RAM, low voltage (2.7 to 5.5 V), low power, high speed (30/33 MHz), two 400KB I²C interfaces

P8xC660X2/661X2

I²C-BUS INTERFACE TIMING (5 V, 3.5 MHz TO 16 MHz) NOT TESTED, GUARANTEED BY DESIGN

All values referred to $V_{IH(min)}$ and $V_{IL(max)}$ levels; see Figure TBD

| Symbol | Figure | Parameter | I ² C-BUS | | | | Unit |
|------------------|--------|--|----------------------|--------|-----------------------------|----------|---------|
| | | | STANDARD MODE | | FAST MODE | | |
| | | | MIN | MAX | MIN | MAX | |
| f_{SCL} | | SCL clock frequency | 0 | 100 | 0 | 400 | kHz |
| t_{BUF} | | Bus free time between a STOP and START condition | 4.7 | – | 1.3 | – | μ s |
| $t_{HD; STA}$ | | Hold time (repeated) START condition. After this period, the first clock pulse is generated | 4.0 | – | 0.6 | – | μ s |
| t_{LOW} | | LOW period of the SCL clock | 4.7 | – | 1.3 | – | μ s |
| t_{HIGH} | | High period of the SCL clock | 4.0 | – | 0.6 | – | μ s |
| $t_{SU; STA}$ | | Set-up time for a repeated START condition | 4.7 | – | 0.6 | – | μ s |
| $t_{HD; DAT}$ | | Data hold time: – for CBUS compatible masters (notes 1, 3) – for I ² C-bus devices (notes 1, 2) | 5.0 0 | – – | – 0 | – 0.9 | μ s |
| $t_{SU; DAT}$ | | Data set-up time | 250 | – | 100 ³ | – | ns |
| $t_{FD; t_{FC}}$ | | Rise time of both SDA and SCL signals | – | 1000 | 20 + 0.1 c_b ⁴ | 300 | ns |
| $t_{FD; t_{FC}}$ | | Fall time of both SDA and SCL signals | – | 300 | | | |
| $t_{SU; STO}$ | | Set-up time for STOP condition | 4.0 | – | 0.6 | – | μ s |
| C_b | | Capacitive load for each bus line | – | 400 | – | 400 | pF |
| t_{SP} | | Pulse width of spikes which must be suppressed by the input filter | – | – | 0 | 50 | ns |

NOTES:

1. A device must internally provide a hold time of at least 300 ns for the SDA signal (referred to the V_{IHmin} of the SCL signal) in order to bridge the undefined region of the falling edge of SCL.
2. The maximum $t_{HD; DAT}$ has only to be met if the device does not stretch the LOW period (t_{LOW}) of the SCL signal.
3. A fast mode I²C-bus device can be used in a standard mode I²C-bus system, but the requirement $t_{SU; DAT} > 250$ ns must then be met. This will automatically be the case if the device does not stretch the LOW period of the SCL signal. If such a device does stretch the LOW period of the SCL signal, it must output the next data bit to the SDA line $t_{R(max)} + t_{SU; DAT} = 1000 + 250 = 1250$ ns (according to the standard-mode I²C-bus specification) before the SCL line is released.
4. C_b = total capacitance of one bus line in pF.

80C51 8-bit microcontroller family 16 KB OTP/ROM, 512B RAM, low voltage (2.7 to 5.5 V), low power, high speed (30/33 MHz), two 400KB I²C interfaces

P8xC660X2/661X2

EXPLANATION OF THE AC SYMBOLS

Each timing symbol has five characters. The first character is always 't' (= time). The other characters, depending on their positions, indicate the name of a signal or the logical status of that signal. The designations are:

- A – Address
- C – Clock
- D – Input data
- H – Logic level HIGH
- I – Instruction (program memory contents)
- L – Logic level LOW, or ALE

- P – $\overline{\text{PSEN}}$
- Q – Output data
- R – $\overline{\text{RD}}$ signal
- t – Time
- V – Valid
- W – $\overline{\text{WR}}$ signal
- X – No longer a valid logic level
- Z – Float

Examples: t_{AVLL} = Time for address valid to ALE LOW.
 t_{LLPL} = Time for ALE LOW to $\overline{\text{PSEN}}$ LOW.

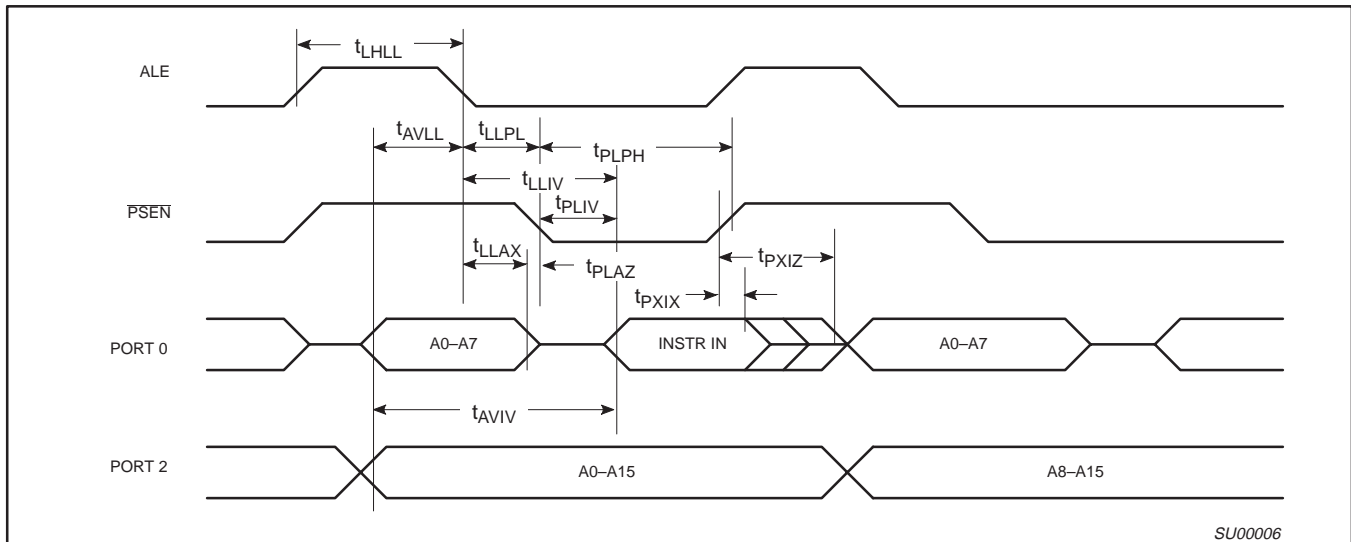

Figure 50. External Program Memory Read Cycle

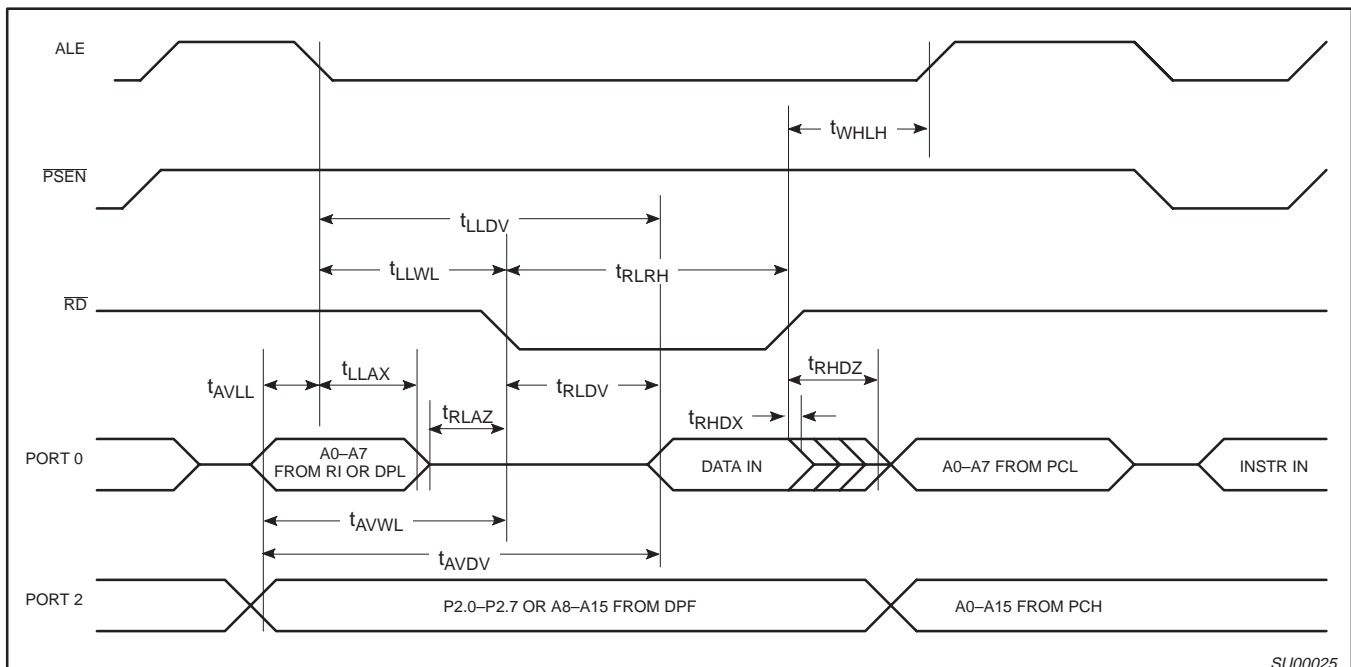

Figure 51. External Data Memory Read Cycle

80C51 8-bit microcontroller family 16 KB OTP/ROM, 512B RAM, low voltage (2.7 to 5.5 V), low power, high speed (30/33 MHz), two 400KB I²C interfaces

P8xC660X2/661X2

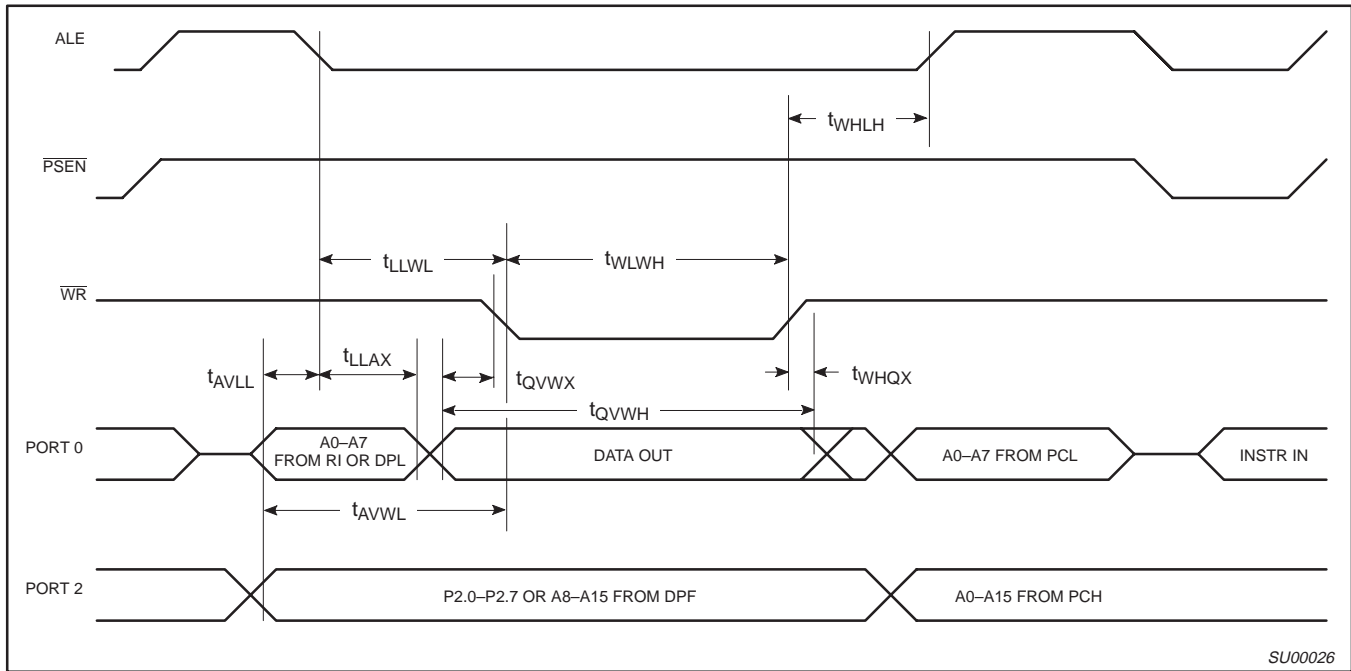

Figure 52. External Data Memory Write Cycle

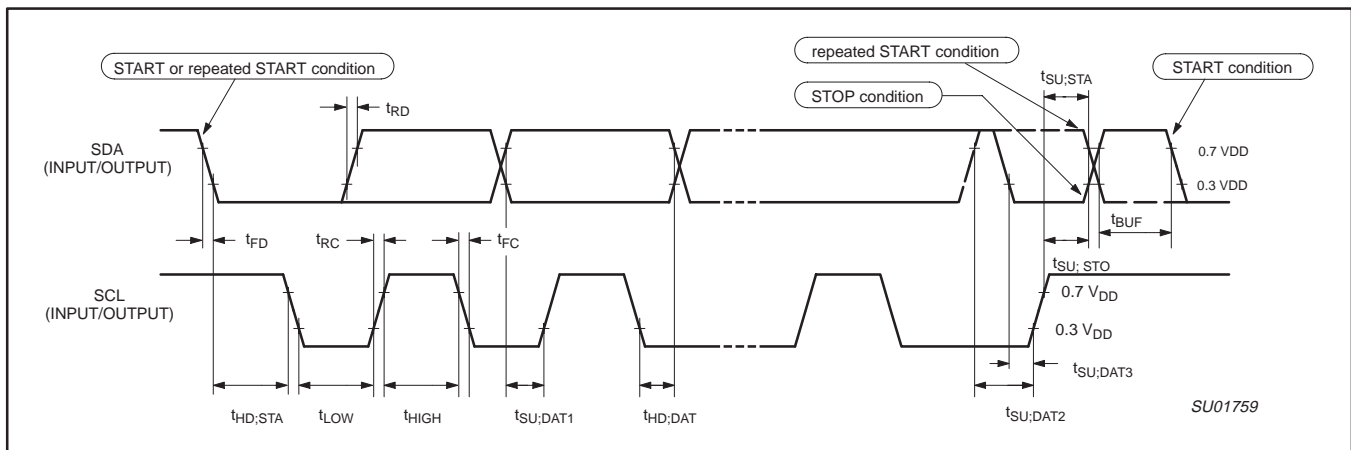

Figure 53. Timing SIO1 (I²C) interface

80C51 8-bit microcontroller family 16 KB OTP/ROM, 512B RAM, low voltage (2.7 to 5.5 V), low power, high speed (30/33 MHz), two 400KB I²C interfaces

P8xC660X2/661X2

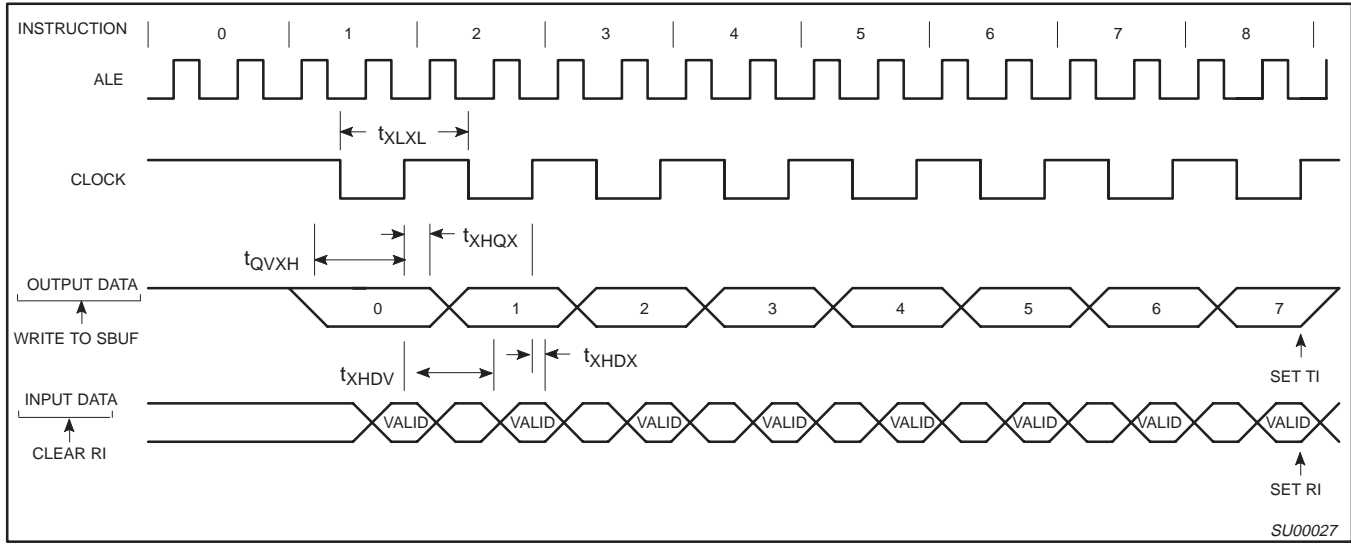

Figure 54. Shift Register Mode Timing

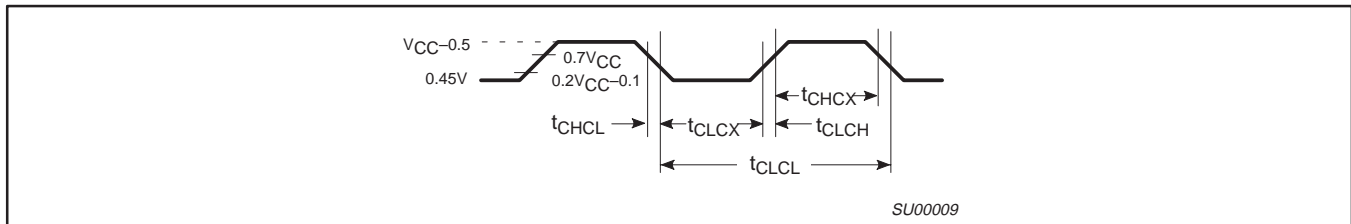

Figure 55. External Clock Drive

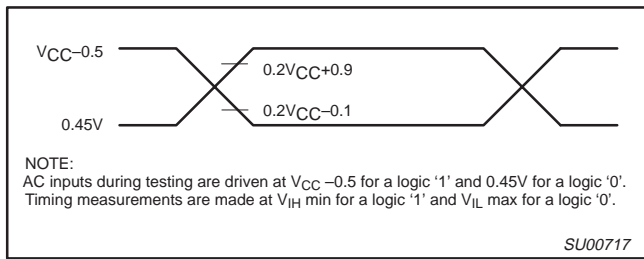

Figure 56. AC Testing Input/Output

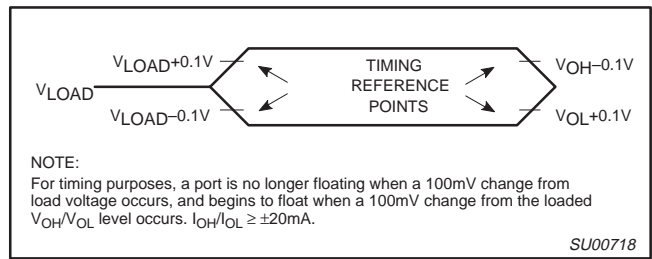

Figure 57. Float Waveform

80C51 8-bit microcontroller family 16 KB OTP/ROM, 512B RAM, low voltage (2.7 to 5.5 V), low power, high speed (30/33 MHz), two 400KB I²C interfaces

P8xC660X2/661X2

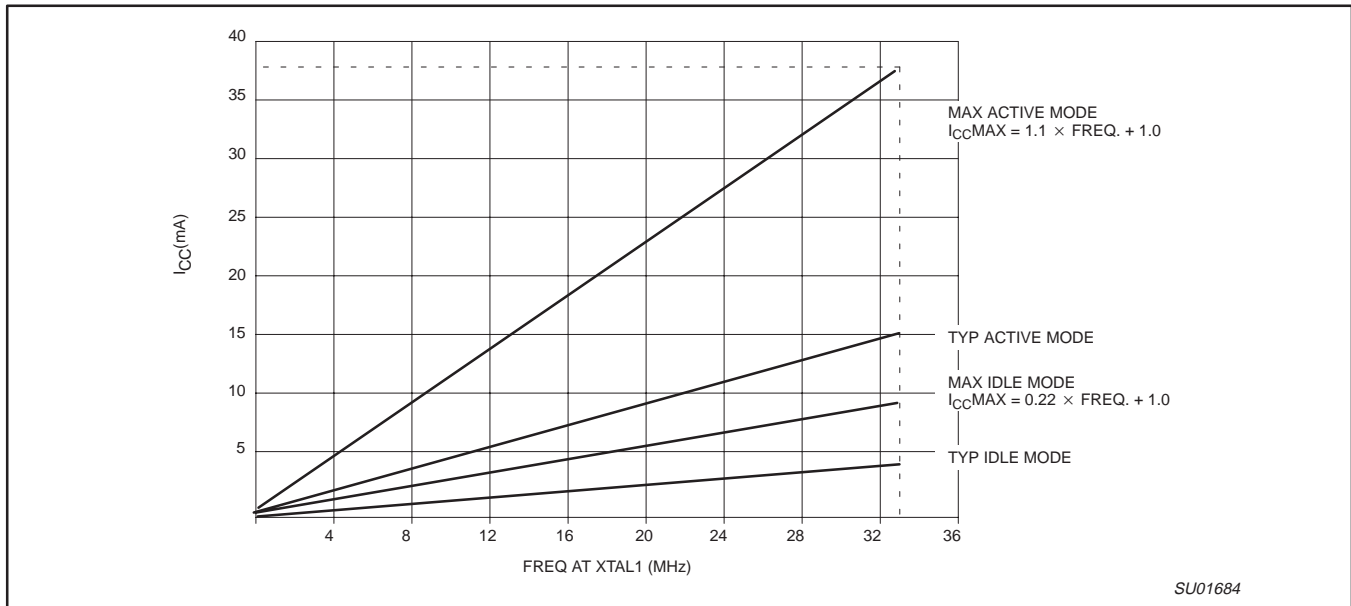

Figure 58. I_{CC} vs. FREQ for 12-clock operation
Valid only within frequency specifications of the specified operating voltage

```

/*
**      as31 version V2.10          / *js* /
**
**
**      source file:  idd_ljmpl.asm
**      list file:   idd_ljmpl.lst   created Fri Apr 20 15:51:40 2001
**
#####
#0000      # AUXR equ 08Eh
#0000      # CKCON equ 08Fh
#
#
#0000      # org 0
#
# LJMP_LABEL:
0000 /75;/8E;/01; #      MOV      AUXR,#001h   ; turn off ALE
0003 /02;/FF;/FD; #      LJMP     LJMP_LABEL   ; jump to end of address space
0005 /00;        #      NOP
#
#FFFD      # org 0fffdh
#
# LJMP_LABEL:
#
FFFD /02;/FD;FF; #      LJMP LJMP_LABEL
# ;      NOP
#
#
*/
    
```

The identifier SU01499 is located in the bottom right corner of the code block area.

Figure 59. Source code used in measuring I_{DD} operational

80C51 8-bit microcontroller family 16 KB OTP/ROM, 512B RAM, low voltage (2.7 to 5.5 V), low power, high speed (30/33 MHz), two 400KB I²C interfaces

P8xC660X2/661X2

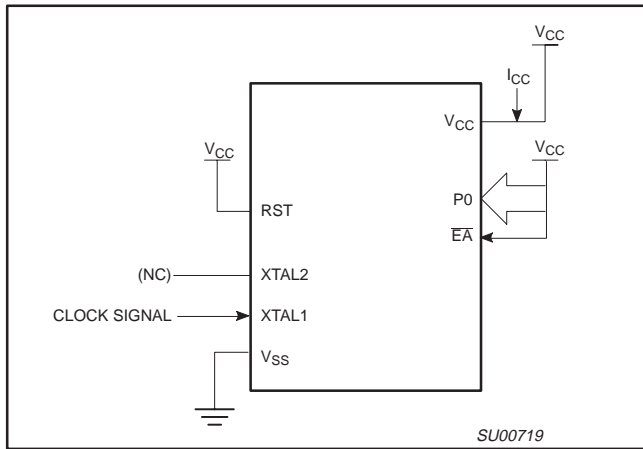

Figure 60. I_{CC} Test Condition, Active Mode
All other pins are disconnected

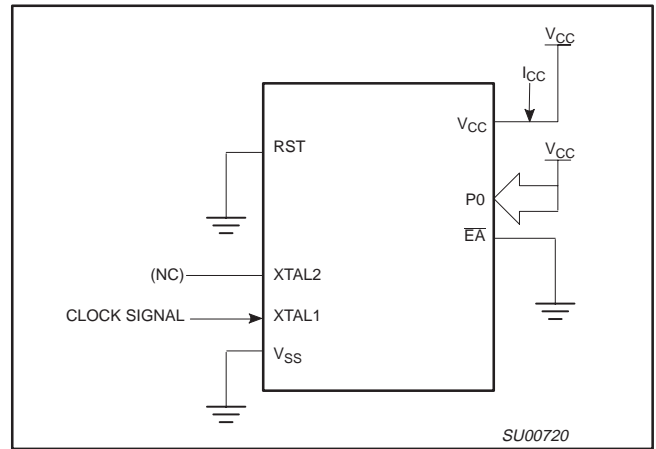

Figure 61. I_{CC} Test Condition, Idle Mode
All other pins are disconnected

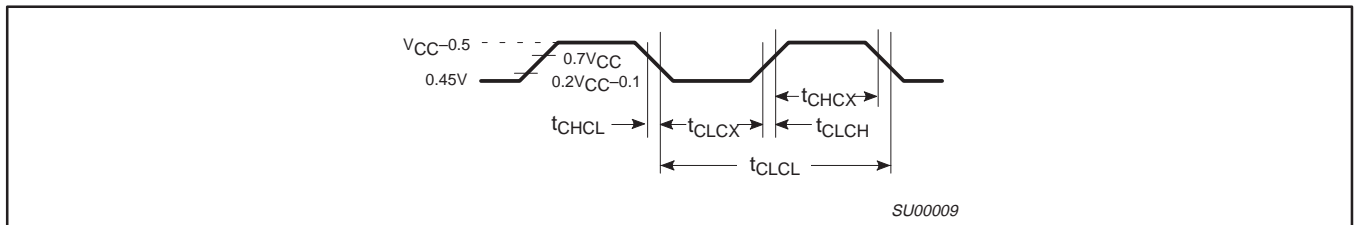

Figure 62. Clock Signal Waveform for I_{CC} Tests in Active and Idle Modes
 $t_{CLCH} = t_{CHCL} = 5\text{ns}$

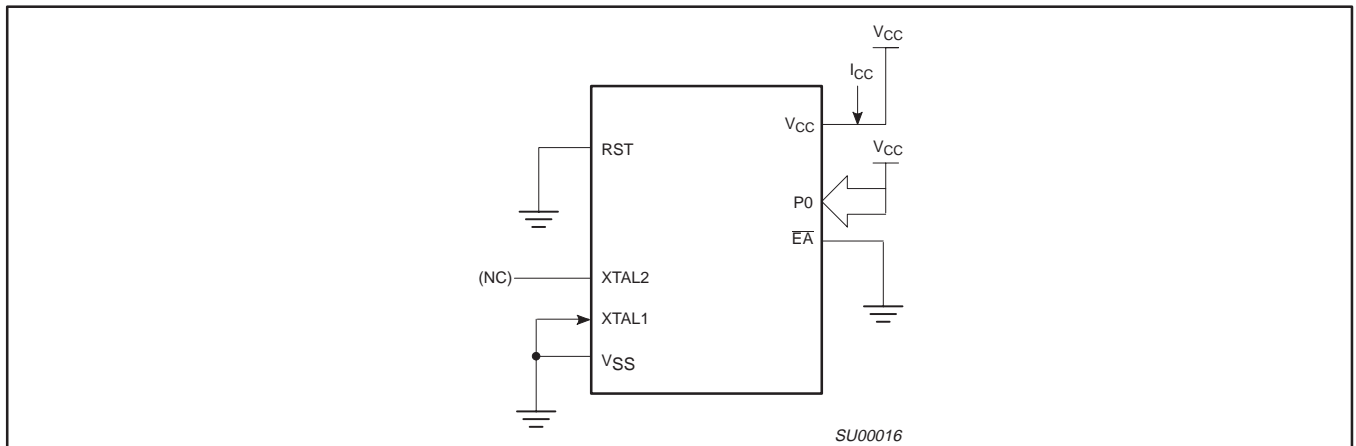

Figure 63. I_{CC} Test Condition, Power Down Mode
All other pins are disconnected. $V_{CC} = 2\text{ V to } 5.5\text{ V}$

80C51 8-bit microcontroller family 16 KB OTP/ROM, 512B RAM, low voltage (2.7 to 5.5 V), low power, high speed (30/33 MHz), two 400KB I²C interfaces

P8xC660X2/661X2

EPROM CHARACTERISTICS

All these devices can be programmed by using a modified Improved Quick-Pulse Programming™ algorithm. It differs from older methods in the value used for V_{PP} (programming supply voltage) and in the width and number of the ALE/PROG pulses.

The family contains two signature bytes that can be read and used by an EPROM programming system to identify the device. The signature bytes identify the device as being manufactured by Philips.

Table 17 shows the logic levels for reading the signature byte, and for programming the program memory, the encryption table, and the security bits. The circuit configuration and waveforms for quick-pulse programming are shown in Figures 64 and 65. Figure 66 shows the circuit configuration for normal program memory verification.

Quick-Pulse Programming

The setup for microcontroller quick-pulse programming is shown in Figure 64. Note that the device is running with a 4 to 6MHz oscillator. The reason the oscillator needs to be running is that the device is executing internal address and program data transfers.

The address of the EPROM location to be programmed is applied to ports 1 and 2, as shown in Figure 64. The code byte to be programmed into that location is applied to port 0. RST, \overline{PSEN} and pins of ports 2 and 3 specified in Table 17 are held at the 'Program Code Data' levels indicated in Table 17. The ALE/PROG is pulsed LOW 5 times as shown in Figure 65.

To program the encryption table, repeat the 5 pulse programming sequence for addresses 0 through 1FH, using the 'Pgm Encryption Table' levels. Do not forget that after the encryption table is programmed, verification cycles will produce only encrypted data.

To program the security bits, repeat the 5 pulse programming sequence using the 'Pgm Security Bit' levels. After one security bit is programmed, further programming of the code memory and encryption table is disabled. However, the other security bits can still be programmed.

Note that the \overline{EA}/V_{PP} pin must not be allowed to go above the maximum specified V_{PP} level for any amount of time. Even a narrow glitch above that voltage can cause permanent damage to the device. The V_{PP} source should be well regulated and free of glitches and overshoot.

Program Verification

If security bits 2 and 3 have not been programmed, the on-chip program memory can be read out for program verification. The address of the program memory locations to be read is applied to ports 1 and 2 as shown in Figure 66. The other pins are held at the 'Verify Code Data' levels indicated in Table 17. The contents of the address location will be emitted on port 0. External pull-ups are required on port 0 for this operation.

If the 64 byte encryption table has been programmed, the data presented at port 0 will be the exclusive NOR of the program byte with one of the encryption bytes. The user will have to know the encryption table contents in order to correctly decode the verification data. The encryption table itself cannot be read out.

Reading the Signature Bytes

The signature bytes are read by the same procedure as a normal verification of locations 030H and 031H, except that P3.6 and P3.7 need to be pulled to a logic LOW. The values are:
 (030H) = 15H indicates manufactured by Philips
 (031H) = C9H indicates P8xC66xX2
 (060H) = 01H (660)
 02H (661)

Program/Verify Algorithms

Any algorithm in agreement with the conditions listed in Table 17, and which satisfies the timing specifications, is suitable.

Security Bits

With none of the security bits programmed the code in the program memory can be verified. If the encryption table is programmed, the code will be encrypted when verified. When only security bit 1 (see Table 18) is programmed, MOVC instructions executed from external program memory are disabled from fetching code bytes from the internal memory, EA is latched on Reset and all further programming of the EPROM is disabled. When security bits 1 and 2 are programmed, in addition to the above, verify mode is disabled. When all three security bits are programmed, all of the conditions above apply and all external program memory execution is disabled.

Encryption Array

64 bytes of encryption array are initially unprogrammed (all 1s).

™Trademark phrase of Intel Corporation.

80C51 8-bit microcontroller family 16 KB OTP/ROM, 512B RAM, low voltage (2.7 to 5.5 V), low power, high speed (30/33 MHz), two 400KB I²C interfaces

P8xC660X2/661X2

Table 17. EPROM Programming Modes

| MODE | RST | PSEN | ALE/PROG | E \bar{A} /V _{PP} | P2.7 | P2.6 | P3.7 | P3.6 | P3.3 |
|-----------------------------------|-----|------|----------|------------------------------|------|------|------|------|------|
| Read signature | 1 | 0 | 1 | 1 | 0 | 0 | 0 | 0 | X |
| Program code data | 1 | 0 | 0* | V _{PP} | 1 | 0 | 1 | 1 | X |
| Verify code data | 1 | 0 | 1 | 1 | 0 | 0 | 1 | 1 | X |
| Pgm encryption table | 1 | 0 | 0* | V _{PP} | 1 | 0 | 1 | 0 | X |
| Pgm security bit 1 | 1 | 0 | 0* | V _{PP} | 1 | 1 | 1 | 1 | X |
| Pgm security bit 2 | 1 | 0 | 0* | V _{PP} | 1 | 1 | 0 | 0 | X |
| Pgm security bit 3 | 1 | 0 | 0* | V _{PP} | 0 | 1 | 0 | 1 | X |
| Program to 6-clock mode | 1 | 0 | 0* | V _{PP} | 0 | 0 | 1 | 0 | 0 |
| Verify 6-clock ⁴ | 1 | 0 | 1 | 1 | e | 0 | 0 | 1 | 1 |
| Verify security bits ⁵ | 1 | 0 | 1 | 1 | e | 0 | 1 | 0 | X |

NOTES:

- '0' = Valid LOW for that pin, '1' = valid HIGH for that pin.
- V_{PP} = 12.75 V ±0.25 V.
- V_{CC} = 5 V ±10% during programming and verification.
- Bit is output on P0.4 (1 = 12x, 0 = 6x).
- Security bit one is output on P0.7.
Security bit two is output on P0.6.
Security bit three is output on P0.3.

* ALE/PROG receives 5 programming pulses for code data (also for user array; 5 pulses for encryption or security bits) while V_{PP} is held at 12.75 V. Each programming pulse is LOW for 100 μs (±10 μs) and HIGH for a minimum of 10 μs.

Table 18. Program Security Bits for EPROM Devices

| PROGRAM LOCK BITS ^{1, 2} | | | | PROTECTION DESCRIPTION |
|-----------------------------------|-----|-----|-----|--|
| | SB1 | SB2 | SB3 | |
| 1 | U | U | U | No Program Security features enabled. (Code verify will still be encrypted by the Encryption Array if programmed.) |
| 2 | P | U | U | MOVC instructions executed from external program memory are disabled from fetching code bytes from internal memory, E \bar{A} is sampled and latched on Reset, and further programming of the EPROM is disabled. |
| 3 | P | P | U | Same as 2, also verify is disabled. |
| 4 | P | P | P | Same as 3, external execution is disabled. Internal data RAM is not accessible. |

NOTES:

- P – programmed. U – unprogrammed.
- Any other combination of the security bits is not defined.

80C51 8-bit microcontroller family 16 KB OTP/ROM, 512B RAM, low voltage (2.7 to 5.5 V), low power, high speed (30/33 MHz), two 400KB I²C interfaces

P8xC660X2/661X2

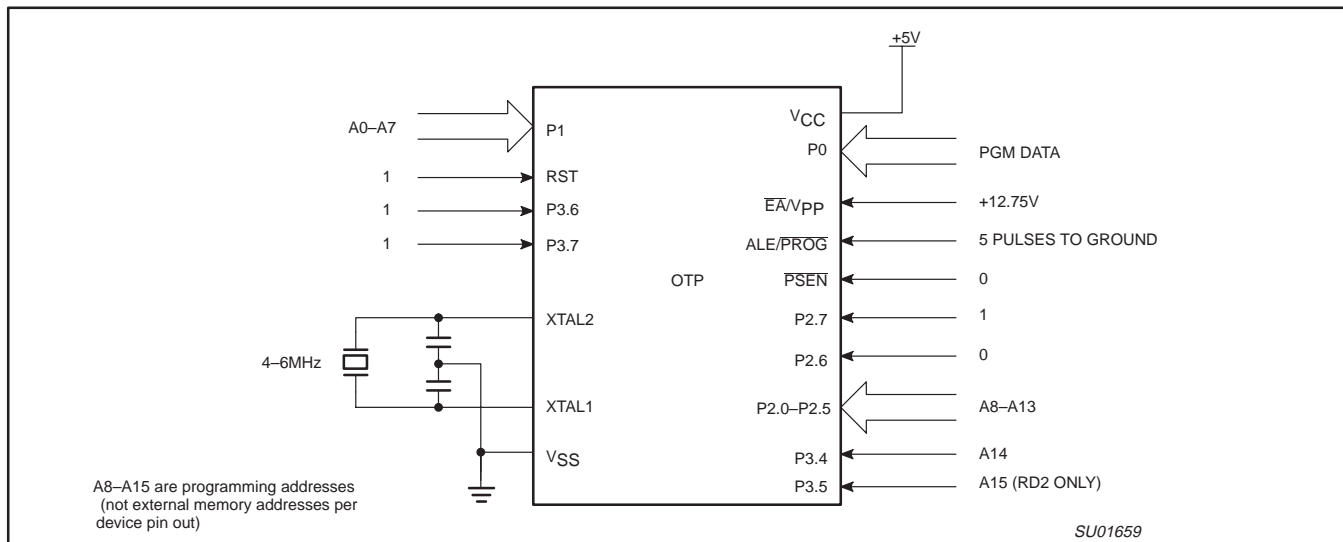

Figure 64. Programming Configuration

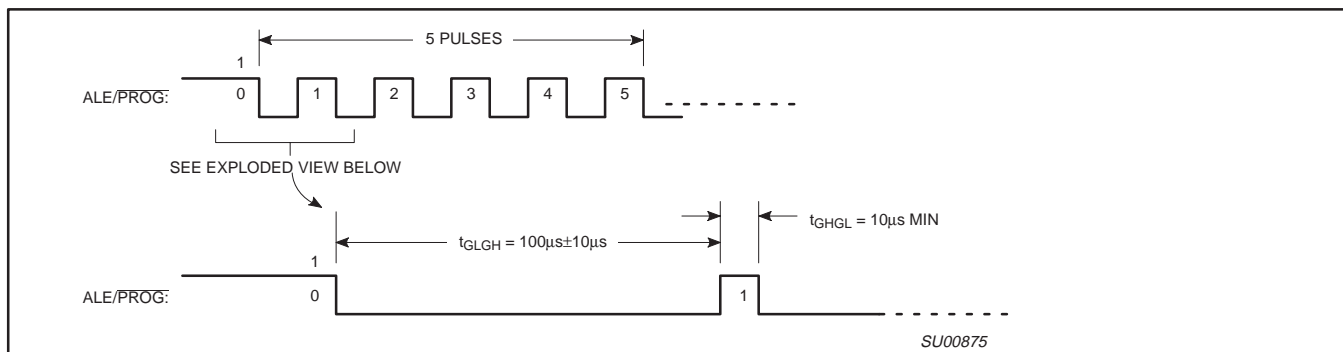

Figure 65. PROG Waveform

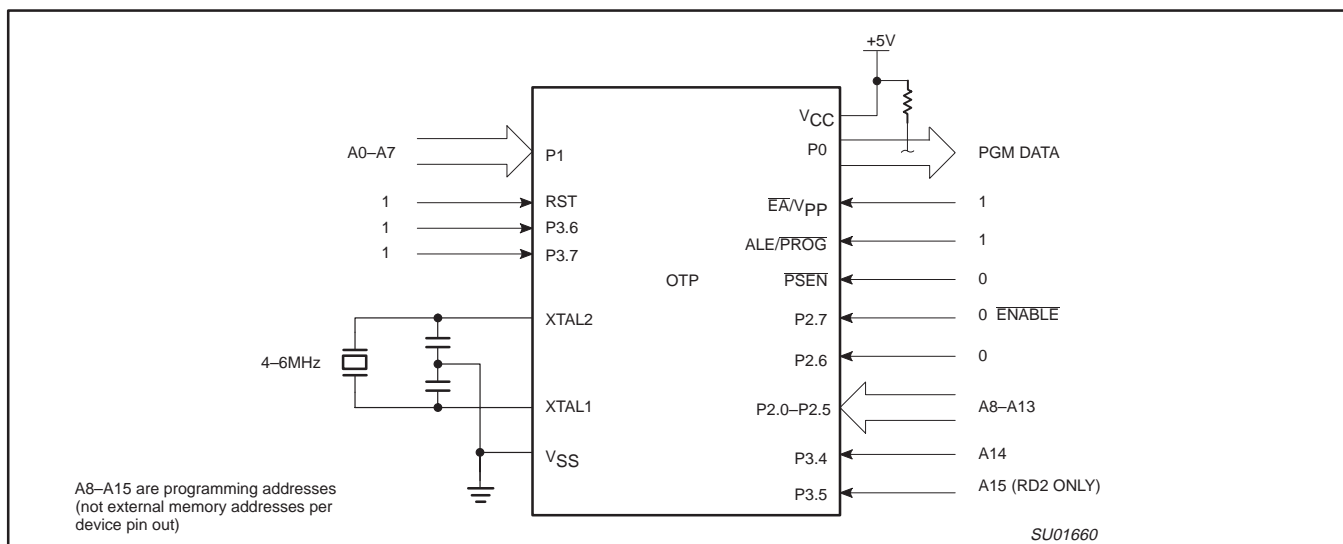

Figure 66. Program Verification

80C51 8-bit microcontroller family 16 KB OTP/ROM, 512B RAM, low voltage (2.7 to 5.5 V), low power, high speed (30/33 MHz), two 400KB I²C interfaces

P8xC660X2/661X2

EPROM PROGRAMMING AND VERIFICATION CHARACTERISTICS

T_{amb} = 21°C to +27°C, V_{CC} = 5V±10%, V_{SS} = 0V (See Figure 67)

| SYMBOL | PARAMETER | MIN | MAX | UNIT |
|---------------------|---|---------------------|---------------------|------|
| V _{PP} | Programming supply voltage | 12.5 | 13.0 | V |
| I _{PP} | Programming supply current | | 50 ¹ | mA |
| 1/t _{CLCL} | Oscillator frequency | 4 | 6 | MHz |
| t _{AVGL} | Address setup to $\overline{\text{PROG}}$ LOW | 48t _{CLCL} | | |
| t _{GHAX} | Address hold after $\overline{\text{PROG}}$ | 48t _{CLCL} | | |
| t _{DVGL} | Data setup to $\overline{\text{PROG}}$ LOW | 48t _{CLCL} | | |
| t _{GHDx} | Data hold after $\overline{\text{PROG}}$ | 48t _{CLCL} | | |
| t _{EHS} | P2.7 ($\overline{\text{ENABLE}}$) HIGH to V _{PP} | 48t _{CLCL} | | |
| t _{SHGL} | V _{PP} setup to $\overline{\text{PROG}}$ LOW | 10 | | μs |
| t _{GHSL} | V _{PP} hold after $\overline{\text{PROG}}$ | 10 | | μs |
| t _{GLGH} | $\overline{\text{PROG}}$ width | 90 | 110 | μs |
| t _{AVQV} | Address to data valid | | 48t _{CLCL} | |
| t _{ELQZ} | $\overline{\text{ENABLE}}$ LOW to data valid | | 48t _{CLCL} | |
| t _{EHQZ} | Data float after $\overline{\text{ENABLE}}$ | 0 | 48t _{CLCL} | |
| t _{GHGL} | $\overline{\text{PROG}}$ HIGH to $\overline{\text{PROG}}$ LOW | 10 | | μs |

NOTE:

1. Not tested.

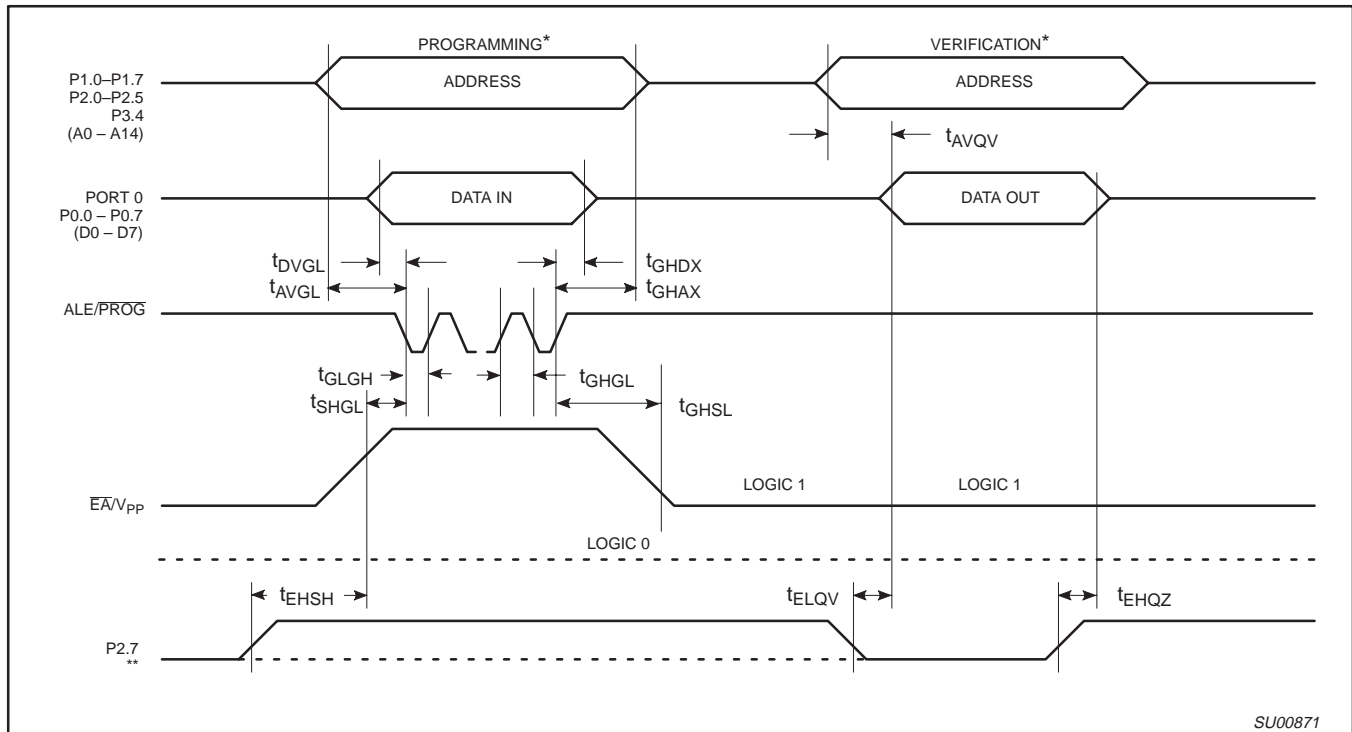

NOTES:

* FOR PROGRAMMING CONFIGURATION SEE FIGURE 64.

FOR VERIFICATION CONDITIONS SEE FIGURE 66.

** SEE TABLE 17.

Figure 67. EPROM Programming and Verification

80C51 8-bit microcontroller family 16 KB OTP/ROM, 512B RAM, low voltage (2.7 to 5.5 V), low power, high speed (30/33 MHz), two 400KB I²C interfaces

P8xC660X2/661X2

MASK ROM DEVICES

Security Bits

With none of the security bits programmed the code in the program memory can be verified. If the encryption table is programmed, the code will be encrypted when verified. When only security bit 1 (see Table 19) is programmed, MOVC instructions executed from external program memory are disabled from fetching code bytes

from the internal memory, \overline{EA} is latched on Reset and all further programming of the EPROM is disabled. When security bits 1 and 2 are programmed, in addition to the above, verify mode is disabled.

Encryption Array

64 bytes of encryption array are initially unprogrammed (all 1s).

Table 19. Program Security Bits

| PROGRAM LOCK BITS ^{1, 2} | | | PROTECTION DESCRIPTION |
|-----------------------------------|-----|-----|--|
| | SB1 | SB2 | |
| 1 | U | U | No Program Security features enabled. (Code verify will still be encrypted by the Encryption Array if programmed.) |
| 2 | P | U | MOVC instructions executed from external program memory are disabled from fetching code bytes from internal memory, \overline{EA} is sampled and latched on Reset, and further programming of the EPROM is disabled. |

NOTES:

1. P – programmed. U – unprogrammed.
2. Any other combination of the security bits is not defined.

80C51 8-bit microcontroller family 16 KB OTP/ROM, 512B RAM, low voltage (2.7 to 5.5 V), low power, high speed (30/33 MHz), two 400KB I²C interfaces

P8xC660X2/661X2

ROM CODE SUBMISSION FOR 16K ROM DEVICES (83C66x)

When submitting ROM code for the 16K ROM devices, the following must be specified:

1. 16k byte user ROM data
2. 64 byte ROM encryption key
3. ROM security bits.

| ADDRESS | CONTENT | BIT(S) | COMMENT |
|----------------|---------|--------|---|
| 0000H to 3FFFH | DATA | 7:0 | User ROM Data |
| 4000H to 403FH | KEY | 7:0 | ROM Encryption Key FFH = no encryption |
| 4040H | SEC | 0 | ROM Security Bit 1 0 = enable security 1 = disable security |
| 4040H | SEC | 1 | ROM Security Bit 2 0 = enable security 1 = disable security |

Security Bit 1: When programmed, this bit has two effects on masked ROM parts:

1. External MOVC is disabled, and
2. \overline{EA} is latched on Reset.

Security Bit 2: When programmed, this bit inhibits Verify User ROM.

NOTE: Security Bit 2 cannot be enabled unless Security Bit 1 is enabled.

If the ROM Code file does not include the options, the following information must be included with the ROM code.

For each of the following, check the appropriate box, and send to Philips along with the code:

- Security Bit #1: Enabled Disabled
- Security Bit #2: Enabled Disabled
- Encryption: No Yes If Yes, must send key file.

80C51 8-bit microcontroller family 16 KB OTP/ROM, 512B RAM, low voltage (2.7 to 5.5 V), low power, high speed (30/33 MHz), two 400KB I²C interfaces

P8xC660X2/661X2

PLCC44: plastic leaded chip carrier; 44 leads

SOT187-2

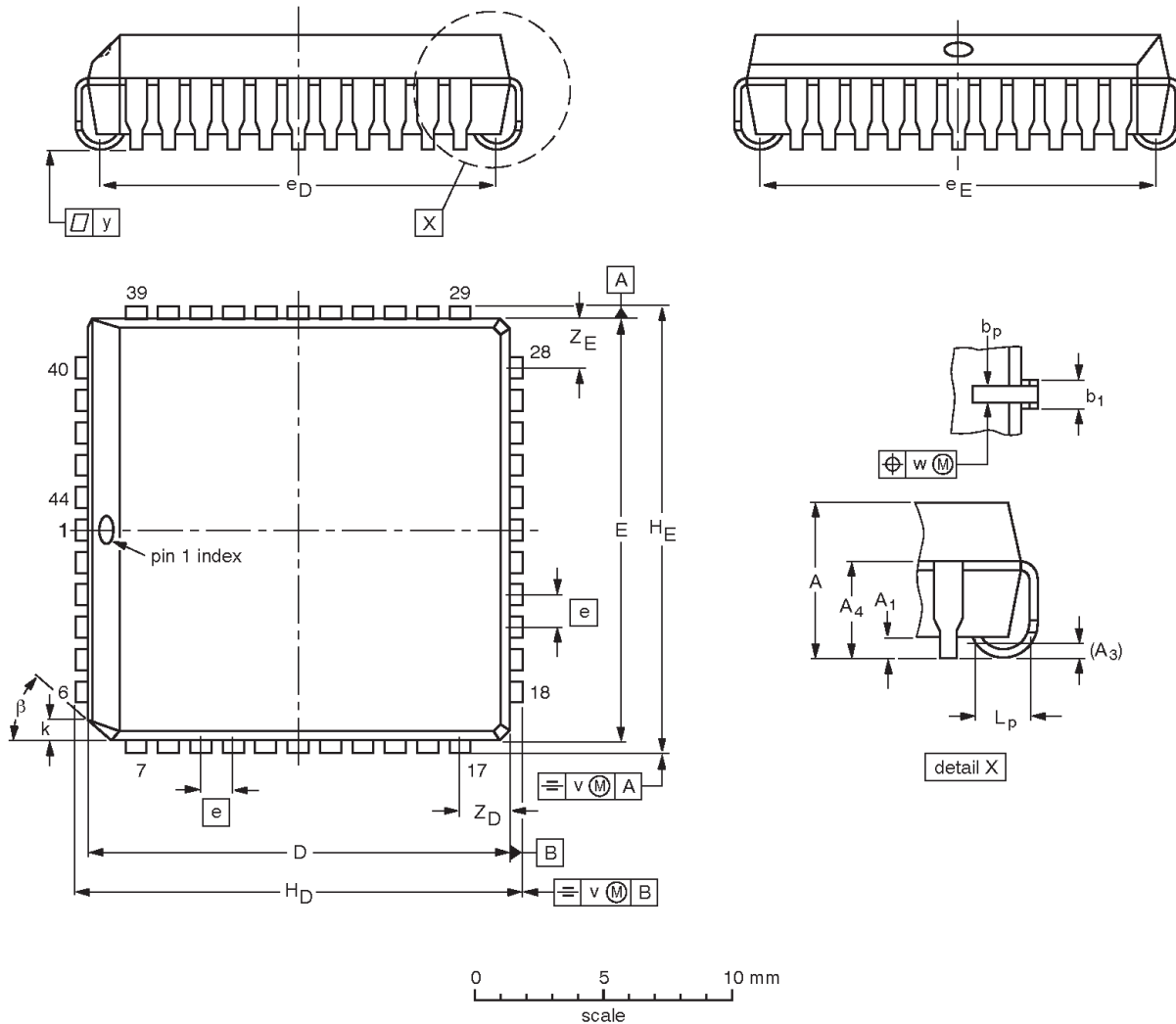

DIMENSIONS (mm dimensions are derived from the original inch dimensions)

| UNIT | A | A ₁ min. | A ₃ | A ₄ max. | b _p | b ₁ | D ⁽¹⁾ | E ⁽¹⁾ | e | e _D | e _E | H _D | H _E | k | L _p | v | w | y | Z _D ⁽¹⁾ max. | Z _E ⁽¹⁾ max. | β |
|--------|----------------|------------------------|----------------|------------------------|----------------|----------------|------------------|------------------|------|----------------|----------------|----------------|----------------|----------------|----------------|-------|-------|-------|---------------------------------------|---------------------------------------|---------|
| mm | 4.57 4.19 | 0.51 | 0.25 | 3.05 | 0.53 0.33 | 0.81 0.66 | 16.66 16.51 | 16.66 16.51 | 1.27 | 16.00 14.99 | 16.00 14.99 | 17.65 17.40 | 17.65 17.40 | 1.22 1.07 | 1.44 1.02 | 0.18 | 0.18 | 0.1 | 2.16 | 2.16 | 45° |
| inches | 0.180 0.165 | 0.02 | 0.01 | 0.12 | 0.021 0.013 | 0.032 0.026 | 0.656 0.650 | 0.656 0.650 | 0.05 | 0.63 0.59 | 0.63 0.59 | 0.695 0.685 | 0.695 0.685 | 0.048 0.042 | 0.057 0.040 | 0.007 | 0.007 | 0.004 | 0.085 | 0.085 | |

Note

1. Plastic or metal protrusions of 0.25 mm (0.01 inch) maximum per side are not included.

| OUTLINE VERSION | REFERENCES | | | | EUROPEAN PROJECTION | ISSUE DATE |
|-----------------|------------|--------|----------|--|---------------------|----------------------|
| | IEC | JEDEC | JEITA | | | |
| SOT187-2 | 112E10 | MS-018 | EDR-7319 | | | 99-12-27 01-11-14 |

80C51 8-bit microcontroller family 16 KB OTP/ROM, 512B RAM, low voltage (2.7 to 5.5 V), low power, high speed (30/33 MHz), two 400KB I²C interfaces

P8xC660X2/661X2

LQFP44: plastic low profile quad flat package; 44 leads; body 10 x 10 x 1.4 mm

SOT389-1

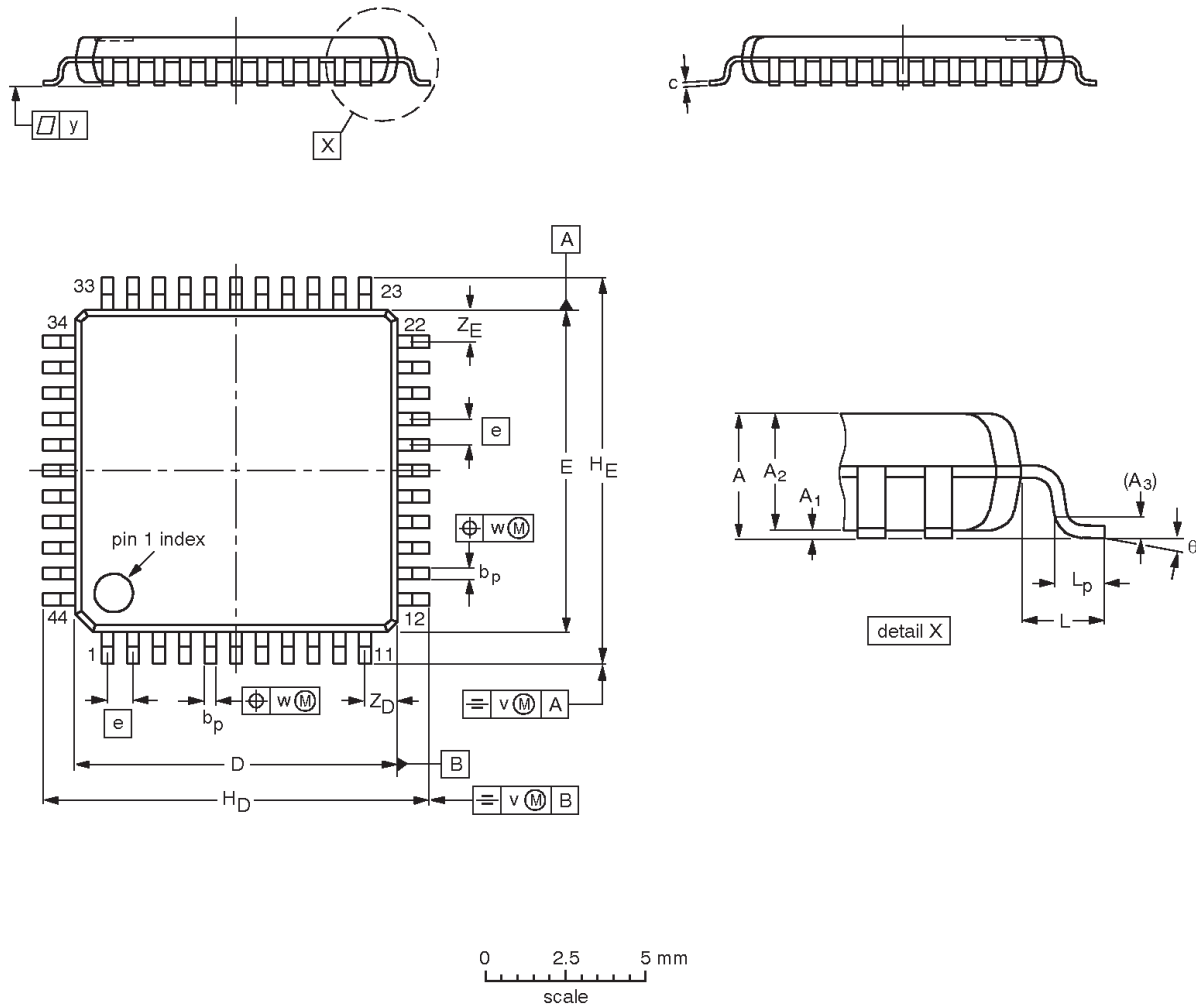

DIMENSIONS (mm are the original dimensions)

| UNIT | A max. | A ₁ | A ₂ | A ₃ | b _p | c | D ⁽¹⁾ | E ⁽¹⁾ | e | H _D | H _E | L | L _p | v | w | y | Z _D ⁽¹⁾ | Z _E ⁽¹⁾ | θ |
|------|--------|----------------|----------------|----------------|----------------|--------------|------------------|------------------|-----|----------------|----------------|---|----------------|-----|-----|-----|-------------------------------|-------------------------------|----------|
| mm | 1.6 | 0.15 0.05 | 1.45 1.35 | 0.25 | 0.45 0.30 | 0.20 0.12 | 10.1 9.9 | 10.1 9.9 | 0.8 | 12.15 11.85 | 12.15 11.85 | 1 | 0.75 0.45 | 0.2 | 0.2 | 0.1 | 1.14 0.85 | 1.14 0.85 | 7° 0° |

Note

1. Plastic or metal protrusions of 0.25 mm maximum per side are not included.

| OUTLINE VERSION | REFERENCES | | | | EUROPEAN PROJECTION | ISSUE DATE |
|-----------------|------------|--------|-------|--|---------------------|-----------------------|
| | IEC | JEDEC | JEITA | | | |
| SOT389-1 | 136E08 | MS-026 | | | | 00-01-19- 02-06-07 |

80C51 8-bit microcontroller family 16 KB OTP/ROM, 512B RAM, low voltage (2.7 to 5.5 V), low power, high speed (30/33 MHz), two 400KB I²C interfaces

P8xC660X2/661X2

REVISION HISTORY

| Rev | Date | Description |
|-----|----------|---|
| _3 | 20031002 | Product data (9397 750 12144); ECN 853-2416 30396 dated 2003 September 30 Modifications: <ul style="list-style-type: none">• Corrected pin description for V_{SS}• Corrected AUXR (Figure 48). |
| _2 | 20030619 | Product data (9397 750 11439); ECN 853-2416 29870 dated 2003 Apr 28 |
| _1 | 20030312 | Product data (9397 750 11126); ECN 853-2416 29538 dated 2003 Feb 13 |

80C51 8-bit microcontroller family 16 KB OTP/ROM, 512B RAM, low voltage (2.7 to 5.5 V), low power, high speed (30/33 MHz), two 400KB I²C interfaces

P8xC660X2/661X2



Purchase of Philips I²C components conveys a license under the Philips' I²C patent to use the components in the I²C system provided the system conforms to the I²C specifications defined by Philips. This specification can be ordered using the code 9398 393 40011.

Data sheet status

| Level | Data sheet status ^[1] | Product status ^{[2] [3]} | Definitions |
|-------|----------------------------------|-----------------------------------|--|
| I | Objective data | Development | This data sheet contains data from the objective specification for product development. Philips Semiconductors reserves the right to change the specification in any manner without notice. |
| II | Preliminary data | Qualification | This data sheet contains data from the preliminary specification. Supplementary data will be published at a later date. Philips Semiconductors reserves the right to change the specification without notice, in order to improve the design and supply the best possible product. |
| III | Product data | Production | This data sheet contains data from the product specification. Philips Semiconductors reserves the right to make changes at any time in order to improve the design, manufacturing and supply. Relevant changes will be communicated via a Customer Product/Process Change Notification (CPCN). |

[1] Please consult the most recently issued data sheet before initiating or completing a design.

[2] The product status of the device(s) described in this data sheet may have changed since this data sheet was published. The latest information is available on the Internet at URL <http://www.semiconductors.philips.com>.

[3] For data sheets describing multiple type numbers, the highest-level product status determines the data sheet status.

Definitions

Short-form specification — The data in a short-form specification is extracted from a full data sheet with the same type number and title. For detailed information see the relevant data sheet or data handbook.

Limiting values definition — Limiting values given are in accordance with the Absolute Maximum Rating System (IEC 60134). Stress above one or more of the limiting values may cause permanent damage to the device. These are stress ratings only and operation of the device at these or at any other conditions above those given in the Characteristics sections of the specification is not implied. Exposure to limiting values for extended periods may affect device reliability.

Application information — Applications that are described herein for any of these products are for illustrative purposes only. Philips Semiconductors make no representation or warranty that such applications will be suitable for the specified use without further testing or modification.

Disclaimers

Life support — These products are not designed for use in life support appliances, devices, or systems where malfunction of these products can reasonably be expected to result in personal injury. Philips Semiconductors customers using or selling these products for use in such applications do so at their own risk and agree to fully indemnify Philips Semiconductors for any damages resulting from such application.

Right to make changes — Philips Semiconductors reserves the right to make changes in the products—including circuits, standard cells, and/or software—described or contained herein in order to improve design and/or performance. When the product is in full production (status 'Production'), relevant changes will be communicated via a Customer Product/Process Change Notification (CPCN). Philips Semiconductors assumes no responsibility or liability for the use of any of these products, conveys no license or title under any patent, copyright, or mask work right to these products, and makes no representations or warranties that these products are free from patent, copyright, or mask work right infringement, unless otherwise specified.

Contact information

For additional information please visit
<http://www.semiconductors.philips.com>. Fax: +31 40 27 24825

© Koninklijke Philips Electronics N.V. 2003
 All rights reserved. Printed in U.S.A.

Date of release: 10-03

For sales offices addresses send e-mail to:
sales.addresses@www.semiconductors.philips.com

Document order number:

9397 750 12144

Let's make things better.

Philips
Semiconductors



PHILIPS