

LNB Supply and control voltage regulator

Feature summary

- Simplest integrated solution for the LNB remote supply and control
- 500mA Guaranteed output current
- Dual input supply for reducing power dissipation
- 22KHZ Built-in tone oscillator (LNBP9 version)
- Fast oscillator start-up for DiSEqC™ encoding (LNBP9 version)
- Auxiliary modulation input for more flexibility (LNBP8 version)
- Stand-by function
- Short circuit and overtemperature protection
- Available in through-hole package

Description

Intended for analog and digital satellite receivers, the LNBP is a monolithic linear voltage regulator, assembled in PowerFlex™, specifically designed to provide the powering voltages and the interfacing signals to the LNB down-converter.

The regulator output can be logic controlled to be 13V or 18V (typ.) by mean of the VSEL pin for the remote controlling of the LNB. In order to reduce the power dissipation of the device when the lowest output voltage is selected, the regulator has 2 supply inputs (V_{CC1} and V_{CC2}). They must be powered respectively at 15V (min.) and 22V (min.), and an internal switch will automatically select the appropriate supply voltage according to the selected output voltage.

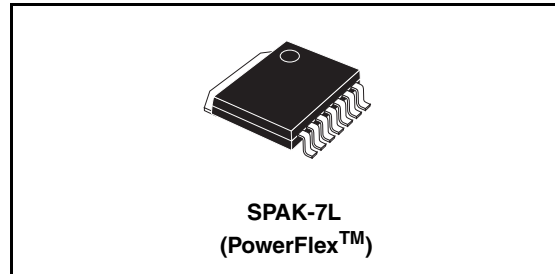

..The TONE pin (only for the LNBP9 version) activates the internal oscillator so that the DC output is modulated by a 22KHz square wave. This internal oscillator is factory trimmed within a tolerance of +/- 2KHz, thus no further adjustment or external components are required. A burst coding of the 22KHz tone can be accomplished thanks to the fast response of the TONE input and the prompt oscillator start-up. This helps designers which want to implement the DiSEqC™ protocols. In order to improve design flexibility and to allow implementation of other LNB remote control standards, an analogic modulation input pin (EXTM) is available (LNBP8 version only). An appropriate DC blocking capacitor must be used to couple the modulating signal source to the EXTM pin. Both versions integrate thermal and short circuit protection. The device is packaged in PowerFlex for an easy through-hole mounting. If an adequate Heatsink is provided and higher power losses are acceptable, both supply pins can be powered by the same 23V source without affecting any other circuit performance.

When the IC is powered and put in Stand-by (EN pin LOW), the regulator output is disabled and the IC power consumption is reduced to 300µA typ.

Order code

Part number	Package	Packaging
	SPAK-7L	Tape & reel
LNBP8	LNBP8K7	LNBP8K7-R
LNBP9	LNBP9K7	LNBP9K7-R

Contents

1	Pin configuration	3
2	Maximum ratings	4
3	Block diagram	5
4	Electrical characteristics	6
5	Typical application circuits	7
6	Package mechanical data	9
7	Revision history	12

1 Pin configuration

Figure 1. Pin connections (top view)

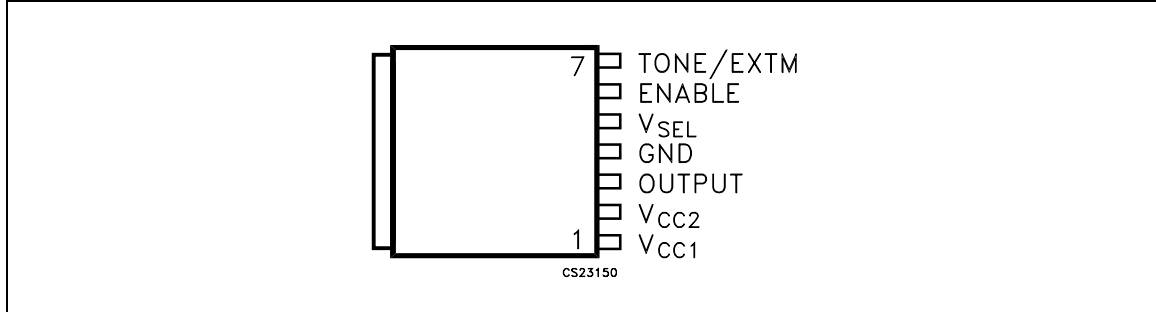

Table 1. Pin descriptions

Pin N°	Name	function
1	V _{CC1}	Supply Input 1: 15V to 25V supply. It is automatically selected when V _O = 13V
2	V _{CC2}	Supply Input 2: 22V to 25V supply. It is automatically selected when V _O = 18V
3	OUTPUT	Regulator output. It is 13V typ. when V _{SEL} LOW and 18V typ. when V _{SEL} HIGH
4	GND	GROUND
5	V _{SEL}	Output Voltage Selection: Logic Control Input; if LOW V _O = 13V, when HIGH V _O = 18V
6	ENABLE	Logic Control Input; force LOW to put the IC in shutdown
7 (LNBP9)	TONE	Logic Control Input; force HIGH to activate the internal 22KHz tone
7 (LNBP8)	EXTM	External Modulation: Needs DC decoupling to the AC source. If not used can be left floating

2 Maximum ratings

Table 2. Absolute maximum ratings

Symbol	Parameter	Value	Unit
V_{CC1}, V_{CC2}	Input voltage	-0.3 to 28	V
ENABLE, TONE, V_{SEL}	Logic input voltage	-0.3 to 7	V
V_O	Output voltage	-0.3 to 28	V
T_J	Operating junction temperature range	-40 to 125	°C
T_{STG}	Storage temperature range	-55 to 150	°C

Note: Absolute Maximum Ratings are those values beyond which damage to the device may occur. Functional operation under these condition is not implied

Table 3. Thermal data

Symbol	Parameter	Value	Unit
R_{thJC}	Thermal resistance junction-case	2	°C/W

3 Block diagram

Figure 2. Block diagram

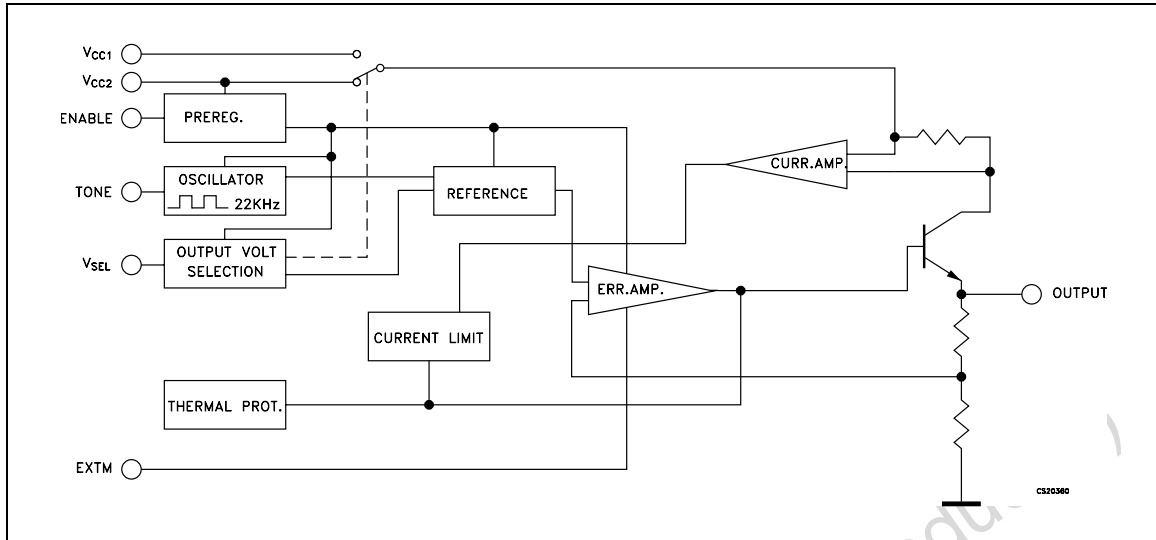

Obsolete Product(s) - Obsolete Product(s)

4 Electrical characteristics

Table 4. Electrical characteristics for LNBP Series ($V_{CC1} = 16V$, $V_{CC2} = 22V$, $C_{I1} = C_{I2} = 0.22\mu F$, $C_O = 0.1\mu F$, Enable = H, Tone = L (LNBP9), EXTM floating (LNBP8), $I_O = 50mA$, $T_J = 0$ to $85^\circ C$ unless otherwise specified.)

Symbol	Parameter	Test conditions	Min.	Typ.	Max.	Unit
V_{CC1}	V_{CC} Supply voltage input 1	$I_O = 500$ mA, TONE = H, $V_{SEL} = L$	15		25	V
V_{CC2}	V_{CC} Supply voltage input 2	$I_O = 500$ mA, TONE = H, $V_{SEL} = H$	22		25	V
V_O	Output voltage	$I_O = 500$ mA, $V_{SEL} = L$	12.5	13	13.5	V
		$I_O = 500$ mA, $V_{SEL} = H$	17.3	18	18.7	V
ΔV_O	Line regulation	$V_{CC1} = 15$ to $18V$, $V_{SEL} = L$		4	40	mV
		$V_{CC2} = 22$ to $25V$, $V_{SEL} = H$		4	40	
ΔV_O	Load regulation	$V_{CC1} = V_{CC2} = 22V$, $I_O = 50$ to $500mA$ $V_{SEL} = L$ or H		80	180	mV
I_{MAX}	Output current limiting		500		800	mA
f_{TONE}	Tone frequency	LNBP9 version, TONE = H	20	22	24	KHz
A_{TONE}	Tone amplitude	LNBP9 version, TONE = H	0.55	0.72	0.9	V
D_{TONE}	Tone duty cycle	LNBP9 version, TONE = H	40	50	60	%
t_r, t_f	Tone rise and fall time	LNBP9 version, TONE = H	5	10	15	μs
G_{EXTM}	External modulation gain	LNBP8 version, $\Delta V_O/\Delta V_{EXTM}$, $f = 10Hz$ to $40KHz$		5		
V_{EXTM}	External modulation input voltage	LNBP8 version, AC Coupling			400	mV
Z_{EXTM}	External modulation impedance	LNBP8 version, $f = 10Hz$ to $40KHz$		400		Ω
V_{IL}	Control input logic LOW	ENABLE, TONE (LNBP9 version), V_{SEL}			0.8	V
V_{IH}	Control input logic HIGH	ENABLE, TONE (LNBP9 version), V_{SEL}	2.5			V
I_{IH}	Control pins input current	$V_{IH} = 5V$, ENABLE, TONE (LNBP9 version), V_{SEL}		20		μA
I_{CC}	Supply current	Output disabled (ENABLE = L)		0.3	1	mA
		Output enabled (ENABLE = H), TONE = H, $I_O = 500mA$		3	6	mA
T_{SHDN}	Temperature shutdown			150		$^\circ C$

5 Typical application circuits

Figure 3. LNBP9 with 22KHz Tone control pin

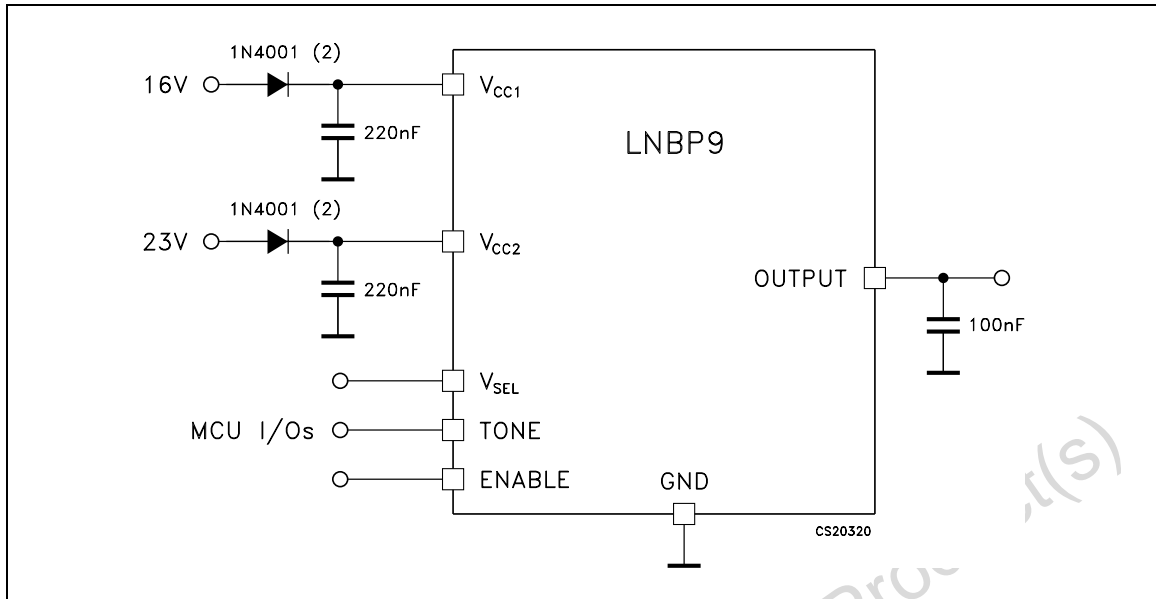

Figure 4. LNBP8 with external 22KHz Input pin (EXTM)

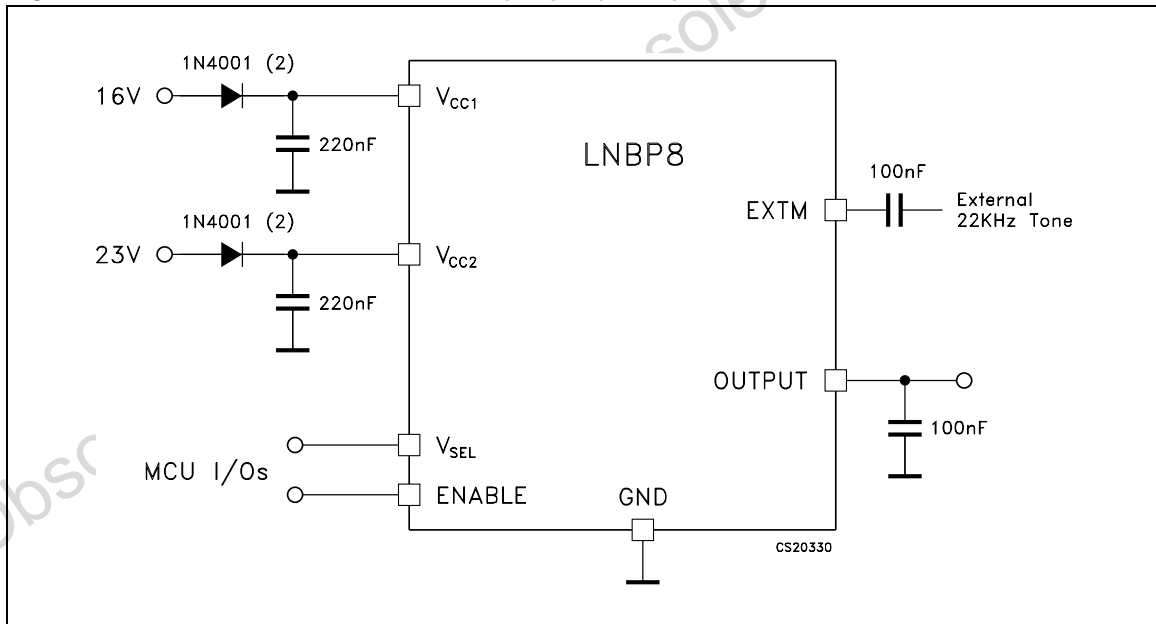
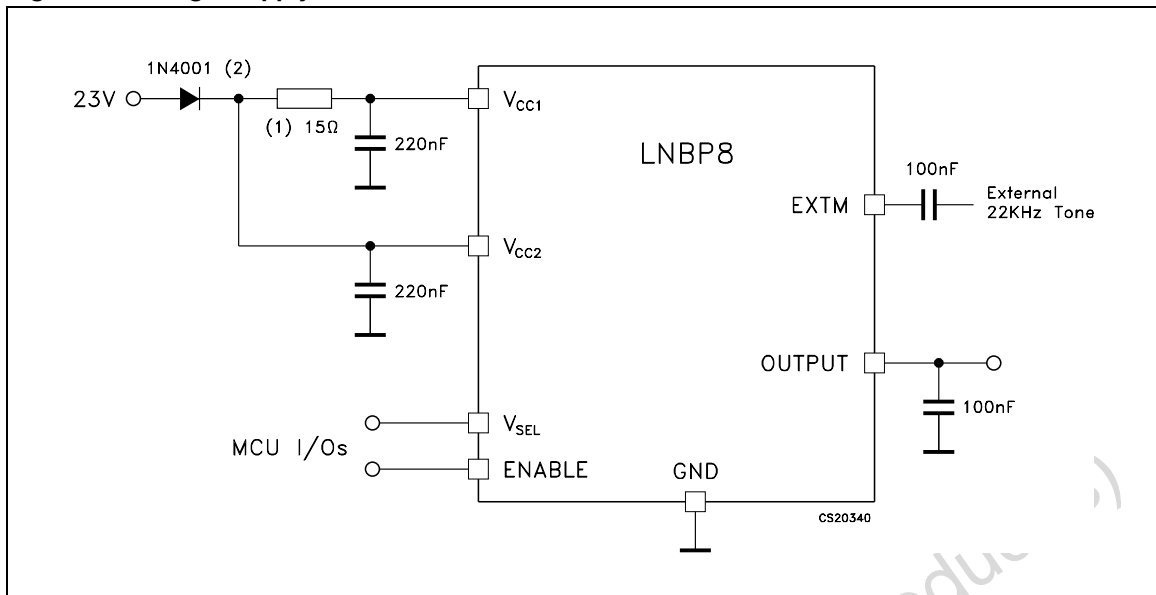

Figure 5. Single supply solution



1. In a single supply configuration the presence of the input resistor in the 12-15Ω range is suggested only to reduce the device power dissipation during the 13V output condition. The resistor can be omitted in spite of power dissipation increase.
2. The input diodes are mandatory to protect the device from any reverse current.

6 Package mechanical data

In order to meet environmental requirements, ST offers these devices in ECOPACK® packages. These packages have a Lead-free second level interconnect. The category of second Level Interconnect is marked on the package and on the inner box label, in compliance with JEDEC Standard JESD97. The maximum ratings related to soldering conditions are also marked on the inner box label. ECOPACK is an ST trademark. ECOPACK specifications are available at: www.st.com.

Obsolete Product(s) - Obsolete Product(s)

SPAK-7L MECHANICAL DATA

DIM.	mm.			inch		
	MIN.	TYP.	MAX.	MIN.	TYP.	MAX.
A	1.78		2.03	0.070		0.080
A2	0.03		0.13	0.001		0.005
C		0.25			0.010	
C1		0.25			0.010	
D	1.02		1.27	0.040		0.050
D1	7.87		8.13	0.310		0.320
F	0.63		0.79	0.025		0.031
G		1.27			0.050	
G1		7.62			0.3	
H1		5.59			0.220	
H2	9.27		9.52	0.365		0.375
H3	8.89		9.14	0.350		0.360
L	10.41		10.67	0.410		0.420
L1		7.49			0.295	
L2	8.89		9.14	0.350		0.360
M	0.79		1.04	0.031		0.041
N		0.25			0.010	
V	3°		6°	3°		6°

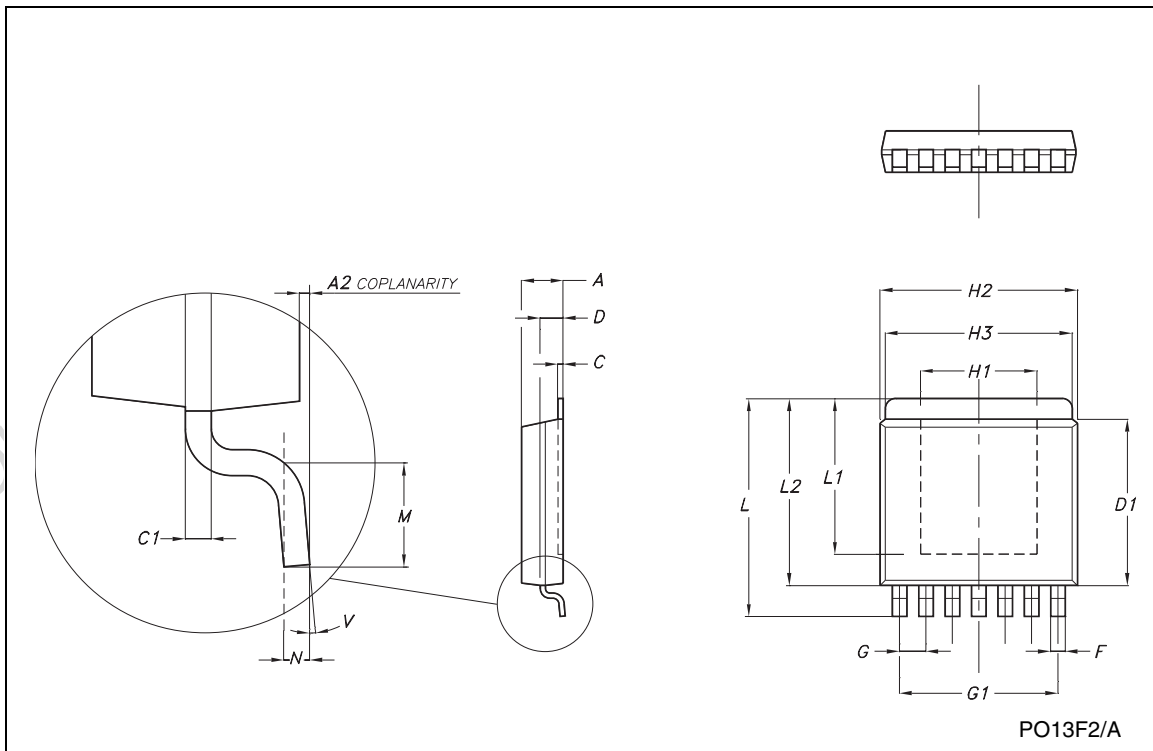

Tape & Reel SPAK-xL MECHANICAL DATA

DIM.	mm.			inch		
	MIN.	TYP	MAX.	MIN.	TYP.	MAX.
A			180			7.086
C	12.8	13.0	13.2	0.504	0.512	0.519
D	20.2			0.795		
N	60			2.362		
T			14.4			0.567
Ao	9.70	9.80	9.90	0.382	0.386	0.390
Bo	10.85	10.95	11.05	0.423	0.427	0.431
Ko	2.30	2.40	2.50	0.090	0.094	0.098
Po	3.9	4.0	4.1	0.153	0.157	0.161
P	11.9	12.0	12.1	0.468	0.472	0.476

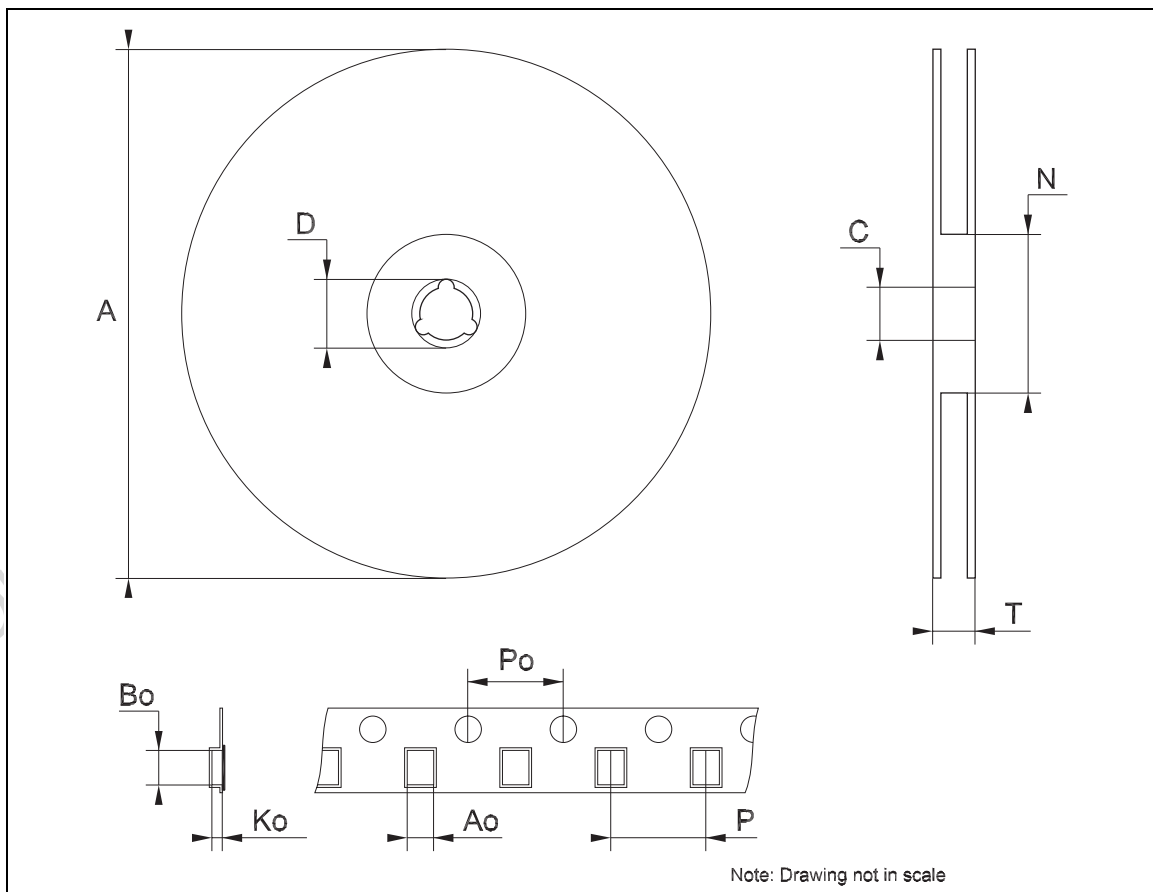

7 Revision history

Table 5. Revision history

Date	Revision	Changes
09-Nov-2004	1	First release.
04-Jul-2005	2	Remove package heptawatt and add package SPAK-7L.
20-Sep-2006	3	Add value V_O on table 2 and new template.

Obsolete Product(s) - Obsolete Product(s)

Please Read Carefully:

Information in this document is provided solely in connection with ST products. STMicroelectronics NV and its subsidiaries ("ST") reserve the right to make changes, corrections, modifications or improvements, to this document, and the products and services described herein at any time, without notice.

All ST products are sold pursuant to ST's terms and conditions of sale.

Purchasers are solely responsible for the choice, selection and use of the ST products and services described herein, and ST assumes no liability whatsoever relating to the choice, selection or use of the ST products and services described herein.

No license, express or implied, by estoppel or otherwise, to any intellectual property rights is granted under this document. If any part of this document refers to any third party products or services it shall not be deemed a license grant by ST for the use of such third party products or services, or any intellectual property contained therein or considered as a warranty covering the use in any manner whatsoever of such third party products or services or any intellectual property contained therein.

UNLESS OTHERWISE SET FORTH IN ST'S TERMS AND CONDITIONS OF SALE ST DISCLAIMS ANY EXPRESS OR IMPLIED WARRANTY WITH RESPECT TO THE USE AND/OR SALE OF ST PRODUCTS INCLUDING WITHOUT LIMITATION IMPLIED WARRANTIES OF MERCHANTABILITY, FITNESS FOR A PARTICULAR PURPOSE (AND THEIR EQUIVALENTS UNDER THE LAWS OF ANY JURISDICTION), OR INFRINGEMENT OF ANY PATENT, COPYRIGHT OR OTHER INTELLECTUAL PROPERTY RIGHT.

UNLESS EXPRESSLY APPROVED IN WRITING BY AN AUTHORIZED ST REPRESENTATIVE, ST PRODUCTS ARE NOT RECOMMENDED, AUTHORIZED OR WARRANTED FOR USE IN MILITARY, AIR CRAFT, SPACE, LIFE SAVING, OR LIFE SUSTAINING APPLICATIONS, NOR IN PRODUCTS OR SYSTEMS WHERE FAILURE OR MALFUNCTION MAY RESULT IN PERSONAL INJURY, DEATH, OR SEVERE PROPERTY OR ENVIRONMENTAL DAMAGE. ST PRODUCTS WHICH ARE NOT SPECIFIED AS "AUTOMOTIVE GRADE" MAY ONLY BE USED IN AUTOMOTIVE APPLICATIONS AT USER'S OWN RISK.

Resale of ST products with provisions different from the statements and/or technical features set forth in this document shall immediately void any warranty granted by ST for the ST product or service described herein and shall not create or extend in any manner whatsoever, any liability of ST.

ST and the ST logo are trademarks or registered trademarks of ST in various countries.

Information in this document supersedes and replaces all information previously supplied.

The ST logo is a registered trademark of STMicroelectronics. All other names are the property of their respective owners.



© 2006 STMicroelectronics - All rights reserved

STMicroelectronics group of companies

Australia - Belgium - Brazil - Canada - China - Czech Republic - Finland - France - Germany - Hong Kong - India - Israel - Italy - Japan - Malaysia - Malta - Morocco - Singapore - Spain - Sweden - Switzerland - United Kingdom - United States of America

www.st.com

