

## CMOS 4-Bit Microcontroller

## TMP47C660AN, TMP47C860AN TMP47C660AF, TMP47C860AF

The TMP47C660A/860A are high speed and high performance 4-bit single chip micro computers, integrating the 8-bit AD converter based on the TLC5-470 series.

Part No.	ROM	RAM	Package	OTP
TMP47C660AN	6144 x 8-bit	384 x 4-bit	P-SDIP64-750-1.78	TMP47P860VN
TMP47C660AF			P-QFP64-1420-1.00A	TMP47P860VF
TMP47C860AN	8192 x 8-bit	512 x 4-bit	P-SDIP64-750-1.78	TMP47P860VN
TMP47C860AF			P-QFP64-1420-1.00A	TMP47P860VF

### Features

- ◆ 4-bit single chip microcomputer
- ◆ Instruction execution time: 1.3  $\mu$ s (at 6 MHz),  
244  $\mu$ s (at 32.8 kHz)
- ◆ 92 basic instructions
  - Table look-up instructions
  - 5-bit to 8-bit data conversion instruction
- ◆ Subroutine nesting: 15 levels max
- ◆ 6 interrupt sources (External: 2, Internal: 4)  
All sources have independent latches each, and multiple interrupt control is available.
- ◆ I/O port (56 pins)
  - Input 2 ports 5 pins
  - Output 4 ports 16 pins
  - I/O 9 ports 35 pins
- ◆ Interval Timer
- ◆ Two 12-bit Timer / Counters  
Timer, event counter, and pulse width measurement mode
- ◆ Watchdog Timer

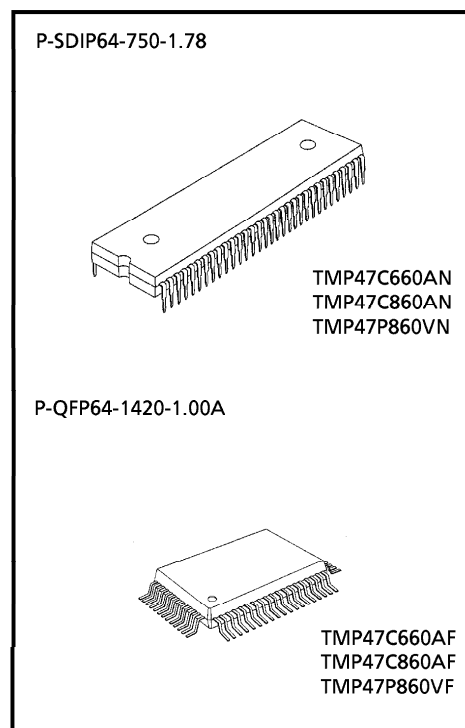

000707EBA1

- For a discussion of how the reliability of microcontrollers can be predicted, please refer to Section 1.3 of the chapter entitled Quality and Reliability Assurance / Handling Precautions.
- TOSHIBA is continually working to improve the quality and reliability of its products. Nevertheless, semiconductor devices in general can malfunction or fail due to their inherent electrical sensitivity and vulnerability to physical stress. It is the responsibility of the buyer, when utilizing TOSHIBA products, to comply with the standards of safety in making a safe design for the entire system, and to avoid situations in which a malfunction or failure of such TOSHIBA products could cause loss of human life, bodily injury or damage to property. In developing your designs, please ensure that TOSHIBA products are used within specified operating ranges as set forth in the most recent TOSHIBA products specifications. Also, please keep in mind the precautions and conditions set forth in the "Handling Guide for Semiconductor Devices," or "TOSHIBA Semiconductor Reliability Handbook" etc..
- The TOSHIBA products listed in this document are intended for usage in general electronics applications (computer, personal equipment, office equipment, measuring equipment, industrial robotics, domestic appliances, etc.). These TOSHIBA products are neither intended nor warranted for usage in equipment that requires extraordinarily high quality and/or reliability or a malfunction or failure of which may cause loss of human life or bodily injury ("Unintended Usage"). Unintended Usage include atomic energy control instruments, airplane or spaceship instruments, transportation instruments, traffic signal instruments, combustion control instruments, medical instruments, all types of safety devices, etc.. Unintended Usage of TOSHIBA products listed in this document shall be made at the customer's own risk.
- The products described in this document are subject to the foreign exchange and foreign trade laws.
- The information contained herein is presented only as a guide for the applications of our products. No responsibility is assumed by TOSHIBA CORPORATION for any infringements of intellectual property or other rights of the third parties which may result from its use. No license is granted by implication or otherwise under any intellectual property or other rights of TOSHIBA CORPORATION or others.
- The information contained herein is subject to change without notice.

- ◆ Serial Interface with 8-bit buffer
  - Simultaneous transmission and reception capability
  - 8/4-bit transfer, external / internal clock, and leading / trailing edge shift mode
- ◆ 8-bit successive approximate type AD converter
  - With sample and hold
  - 8 analog inputs
  - Conversion time: 32  $\mu$ s (at 6 MHz)
- ◆ Remote control signal pre-processing capability
- ◆ High current outputs
  - LED direct drive capability (typ. 20 mA  $\times$  8 bits)
- ◆ Dual-clock operation
  - High-speed/Low-power-consumption operating mode
- ◆ Hold function
  - Battery/Capacitor back-up
- ◆ Real Time Emulator: BM47C860A

Pin Assignments (Top View)

(1) P-SDIP64-750-1.78

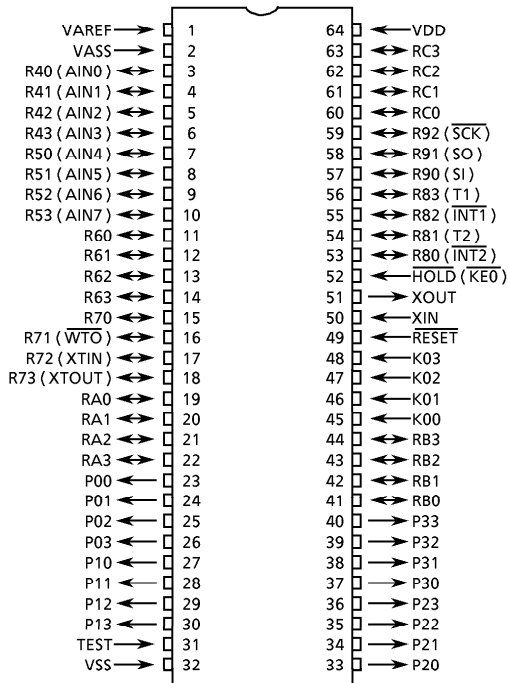

(2) P-QFP64-1420-1.00A

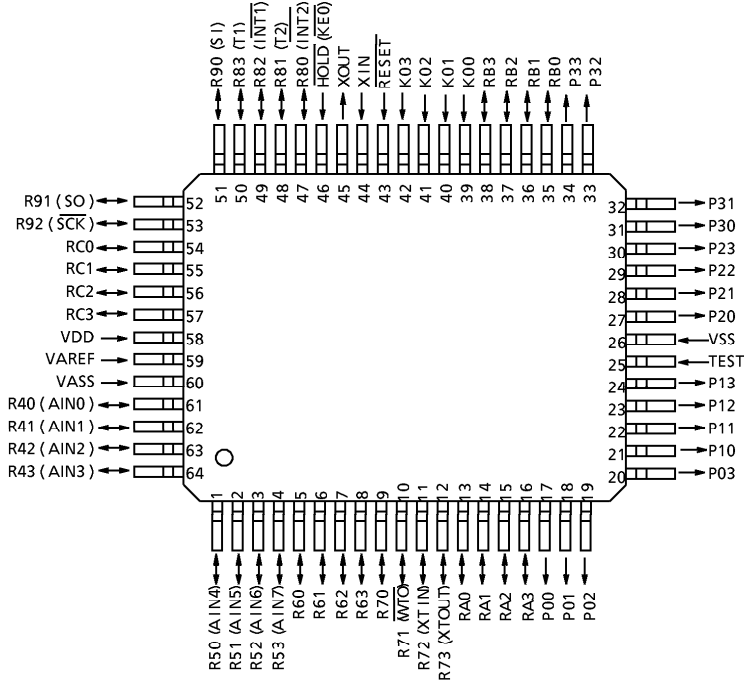

Block Diagram

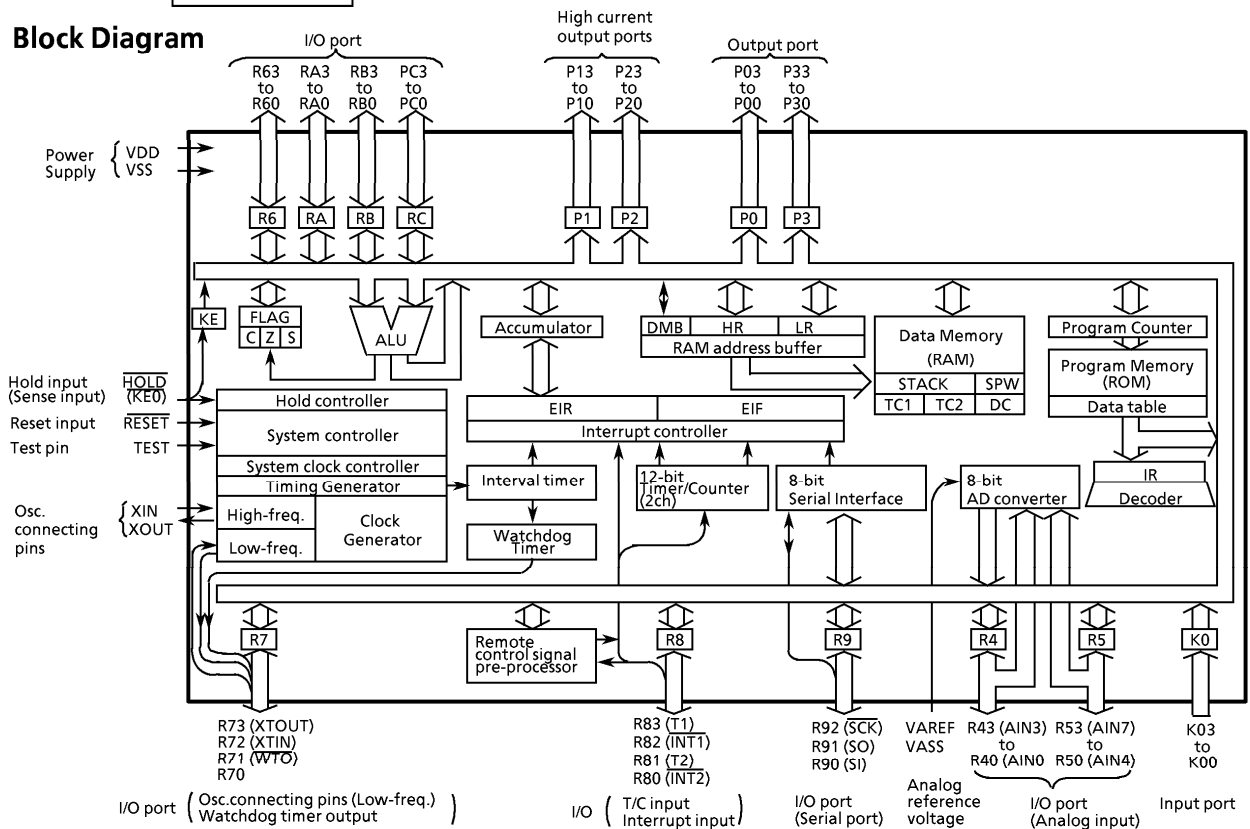

## Pin Function

Pin Name	Input / Output	Functions	
K03 to K00	Input	4-bit input port	
P03 to P00	Output	4-bit output port with latch	
P13 to P10		4-bit output port with latch.	
P23 to P20		8-bit data are output by the 5-bit to 8-bit data conversion instruction [OUTB @HL].	
P33 to P30		4-bit output port with latch	
R53 (AIN7) to R40 (AIN0)	I/O (Input)	4-bit I/O port with latch. When used as input port, watchdog timer output or analog input, the latch must be set to "1".	AD converter analog input
R63 to R60	I/O		
R73 (XTOUT)	I/O (Output)	Set to Dual-clock operating mode, when R73, R72 pin use as clock generator.	Resonator connecting pin (Low-freq.). For inputting external clock, XTIN is used and XTOUT is opened.
R72 (XTIN)	I/O (Input)		
R71 (WTO)	I/O (Output)	Can be set, cleared, and tested for each bit as specified by L register indirect addressing bit manipulation instructions.	Watchdog timer output
R70	I/O		
R83 (T1)	I/O (Input)	4-bit I/O port with latch. When used as input port, external interrupt input pin, or timer/counter external input pin, the latch must be set to "1".	Timer/Counter 1 external input
R82 (INT1)			External interrupt 1 input
R81 (T2)			Timer/Counter 2 external input
R80 (INT2)			External interrupt 2 or REMO-COM input
R92 (SCK)	I/O (I/O)	3-bit I/O port with latch. When used as input port or serial port, the latch must be set to "1".	Serial clock I/O
R91 (SO)	I/O (Output)		Serial data output
R90 (SI)	I/O (Input)		Serial data input
RA3 to RA0	I/O	4-bit I/O port with latch. When used as input port, the latch must be set to "1".	
RB3 to RB0			
RC3 to RC0			
XIN	Input	Resonator connecting pin (High-frequency) .	
XOUT	Output	For inputting external clock, XIN is used and XOUT is opened.	
RESET	Input	Reset signal input	
HOLD (KE0)	Input (Input)	HOLD request/release signal input	Sence input
TEST	Input	Test pin for out-going test. Be opened or fixed to low level.	
VDD	Power supply	+ 5 V	
VSS		0 V (GND)	
VAREF		AD converter analog reference voltage (High)	
VASS		AD converter analog reference voltage (Low)	

## Operational Description

### 1. System Configuration

- ◆ Internal CPU Function
  - 2.1 Program Counter (PC)
  - 2.2 Program Memory (ROM)
  - 2.3 H Register, L Register, and Data Memory Bank Selector (DMB)
  - 2.4 Data Memory (RAM)
    - Stack
    - Stack Pointer Word (SPW)
    - Data Counter (DC)
  - 2.5 Accumulator
  - 2.6 Flags
  - 2.7 Clock Generator, Timing Generator, System Clock Controller
  - 2.8 Interrupt Controller
  - 2.9 Reset Circuit
- ◆ Peripheral Hardware Function
  - 3.1 Input/Output Ports
  - 3.2 Interval Timer
  - 3.3 Timer / Counters (TC1, TC2)
  - 3.4 Watchdog Timer
  - 3.5 Remote Control Pulse Detector
  - 3.6 AD Converter
  - 3.7 Serial Interface

Concerning the above component parts, the hardware configuration and functions are described.

### 2. Internal CPU Function

#### 2.1 Program Counter (PC)

The program counter is a 13-bit binary counter which indicates the address of the program memory storing the next instruction to be executed. Normally, the PC is incremented by the number of bytes of the instruction every time it is fetched. When a branch instruction or a subroutine instruction has been executed or an interrupt has been accepted, the specified values listed in Table 2-1 are set to the PC. The PC is initialized to "0" during reset.

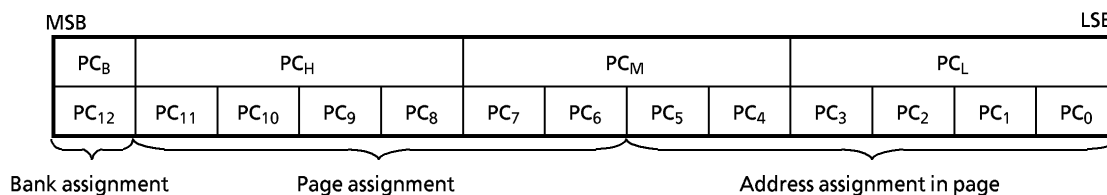

Figure 2-1. Configuration of program counter

The PC can directly address an 8192-byte address space. However, with the short/middle branch and subroutine call instructions, the following points must be considered:

(1) Short branch instruction [BSS a]

In [BSS a] instruction execution, when the branch condition is satisfied the status flag is "1", the value specified in the instruction is set to the lower 6 bits of the PC. That is, [BSS a] becomes the in-page branch instruction. When [BSS a] is stored at the last address of the page, the upper 7 bits of the PC point the next page, so that branch is made to the next page.

(2) Middle branch instruction [BS a]

In [BS a] instruction execution, when the branch condition is satisfied, the value specified in the instruction is set to the lower 12 bits of the PC. That is, [BS a] becomes the in-bank branch instruction.

When first byte or second byte of this instruction is stored at the last address of the bank, the most significant bit of the PC point the next bank, so that branch is made to the next bank.

(3) Subroutine call instruction [CALL a]

In [CALL a] instruction execution, the contents of the PC are saved to the stack then the value specified by the instruction is set to the PC. The address which can be specified by the instruction consists of 11 bits and the upper 2 bits of the PC is always "0". Therefore, the entry address of the subroutine should be within an address range of 0000H through 07FFH.

Table 2-1. Status change of program counter

Instruction or Operation	Condition	Program Counter (PC)														
		PC <sub>12</sub>	PC <sub>11</sub>	PC <sub>10</sub>	PC <sub>9</sub>	PC <sub>8</sub>	PC <sub>7</sub>	PC <sub>6</sub>	PC <sub>5</sub>	PC <sub>4</sub>	PC <sub>3</sub>	PC <sub>2</sub>	PC <sub>1</sub>	PC <sub>0</sub>		
I N S T R U C T I O N	BSL a	SF = 1 (Branch condition is satisfied)	Immediata data specified by the instruction													
		SF = 0 (Branch condition is not satisfied)	+ 3													
	BS a	SF = 1	Lower 12-bit address ≠ FFE, FFF <sub>H</sub>	Hold	Immediata data specified by the instruction											
			Lower 12-bit address = FFE, FFF <sub>H</sub> (Last address in bank)	+ 1	Immediata data specified by the instruction											
		SF = 0	+ 2													
	BSS a	SF = 1	Lower 6-bit address ≠ 3F <sub>H</sub>	Hold						Immediata data specified by the instruction						
			Lower 6-bit address = 3F <sub>H</sub> (Last address in page)	+ 1						Immediata data specified by the instruction						
		SF = 0	+ 1													
	CALL a		0	0	Immediata data specified by the instruction											
	CALLS a		0	0	0	0	0	The value generated by the immediate data specified by the instruction					1	1	0	
	RET		The return address restored from stack													
	RETI		The return address restored from stack													
Others		Incremented by the number of bytes in the instruction														
Interrupt acceptance		0	0	0	0	0	0	0	0	0	Interrupt vector			0		
Reset		0	0	0	0	0	0	0	0	0	0	0	0	0		

## 2.2 Program Memory (ROM)

Programs and fixed data are stored in the program memory. The instruction to be executed next is read from the address indicated by the contents of the PC. The fixed data can be read by using the table look-up instructions or 5-bit to 8-bit data conversion instruction.

### (1) Table look-up instructions [LDL A,@DC], [LDH A,@DC+]

The table look-up instructions read the lower and upper 4 bits of the fixed data stored at the address specified in the data counter (DC) to place them into the accumulator. [LDL A,@DC] instruction reads the lower 4 bits of fixed data and [LDH A,@DC+] instruction reads the upper 4 bits. The DC is a 12-bit register, and it can specify an address within the range of 1000<sub>H</sub> through 1FFF<sub>H</sub> of the program memory.

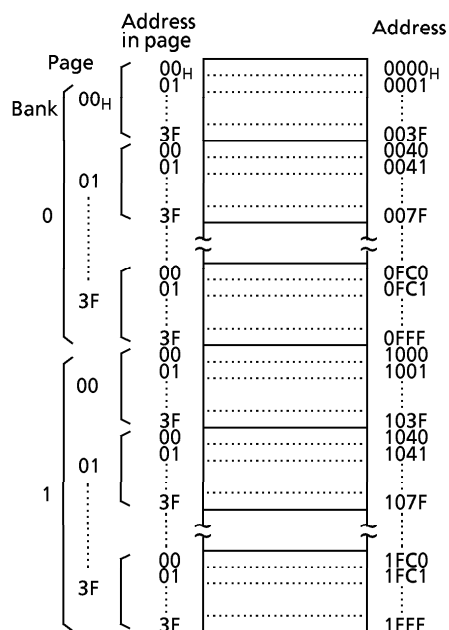

Figure 2-2. Configuration of program memory

### (2) 5-bit to 8-bit data conversion instruction [OUTB @HL]

The 5-bit to 8-bit data conversion instruction reads the fixed data (8 bits) from the data conversion table in the program memory to output the upper 4 bits to port P2 and the lower 4 bits to port P1. The table is located in the last 32-byte space (addresses 17E0 through 17FF<sub>H</sub> for the TMP47C660A and addresses 1FE0<sub>H</sub> through 1FFF<sub>H</sub> for the TMP47C860A) in the program memory with the lower address consisting of the 5 bits obtained by linking the data memory contents specified by the HL register pair and the content of the carry flag.

This instruction is suitable for such applications as converting BCD data into an output code to the 7-segment display elements.

Example: The following shows that the BCD data at address 2F<sub>H</sub> in data memory is converted into the 7-segment code (anode common LED) to be output to ports P2 and P1.

```
LD      HL, #2FH ; HL←2FH (Data memory address is set)
TEST   CF        ; CF←0 (The table is specified at addresses 1FE0H - 1FEFH)
OUTB   @HL
      ⋮
ORG    1FE0H     ; Data conversion table
DATA   0C0H, 0F9H, 0A4H, 0B0H, 99H, 92H, 82H, 0D8H, 80H, 98H
```

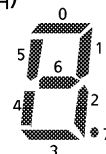

### 2.2.1 Program memory map

Figure 2-3 shows the program memory map. Address 0000 through 0086<sub>H</sub> and 1FE0 through 1FFF<sub>H</sub> for the TMP47C860A, 0000 through 0086<sub>H</sub> and 17E0 through 17FF<sub>H</sub> for the TMP47C660A, of the program memory are also used for special purposes.

## 2.2.2 Program memory capacity

The TMP47C860A has 8192 × 8 bits (addresses 0000 through 1FFF<sub>H</sub>) and the TMP47C660A has 6144 × 8 bits (0000 through 17FF<sub>H</sub>), of the program memory (mask ROM).

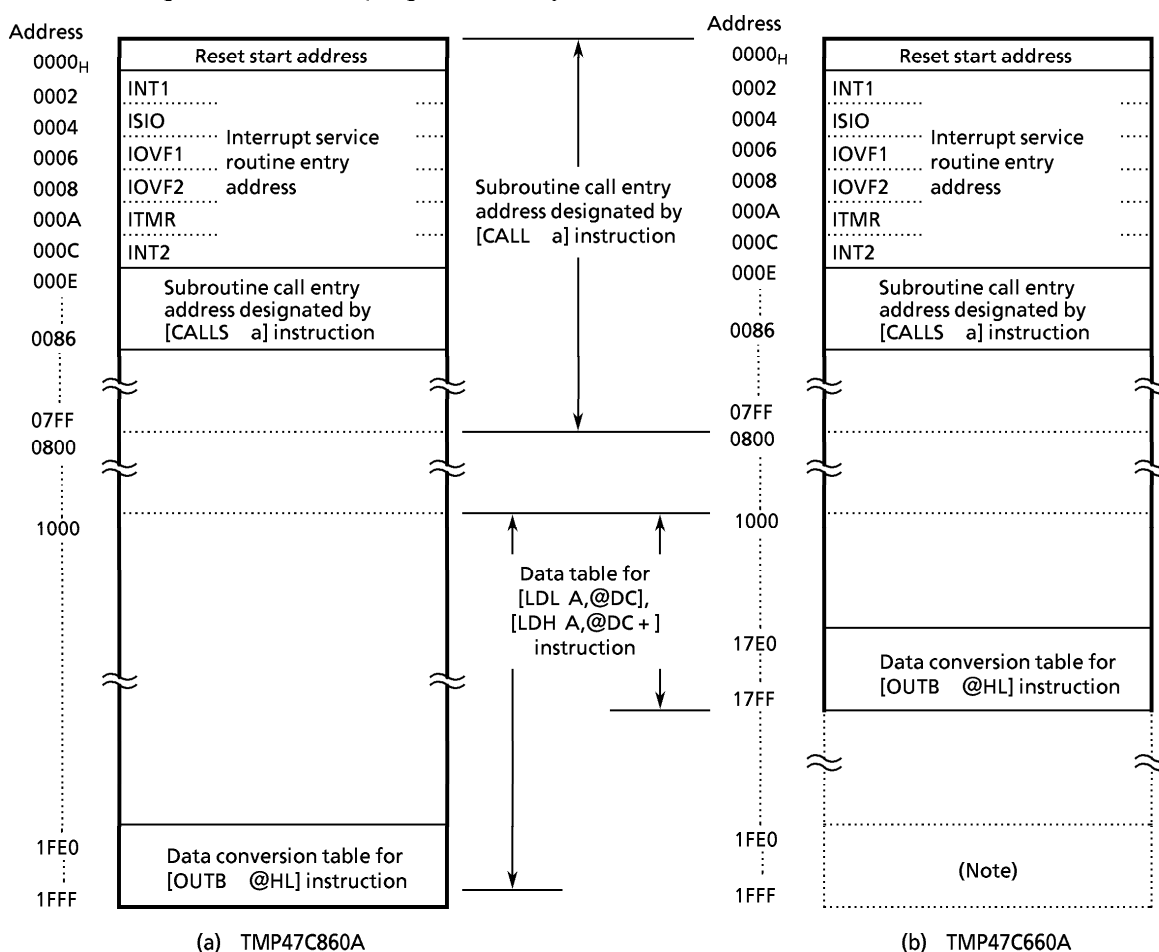

Figure 2-3. Program memory map

## 2.3 H Register, L Register, and Data Memory Bank Selector (DMB)

The H register and the L register are 4-bit general registers. They are also used as a register pair (HL) for the data memory (RAM) addressing pointer. The data memory consists of pages, each page being 16 words long (1 word = 4 bits). The H register specifies a page and the L register specifies an address in the page. The data memory consists of two banks (bank0 and bank1). The data memory bank selector (DMB) is a 1-bit register to specify a data memory bank. During reset, the DMB is initialized to "0". The DMB is set or cleared by the [CLR DMB] or [SET DMB] instructions. The currently selected data memory bank can be known by executing the [TEST DMB] or [TESTP DMB] instruction.

The L register has the automatic post-increment/decrement capability, implementing the execution of composite instructions. For example, [ST A,@HL +] instruction automatically increments the contents of the L register after data transfer. During the execution [SET @L], [CLR @L], or [TEST @L] instruction, the L register is also used to specify the bits corresponding to I/O port pins R73 through R40 (the indirect addressing of port bits by the L register).



Example 1: To write immediate values "5" and "FH" to data memory (bank 0) addresses 10H and 11H.

```
CLR    DMB      ; DMB ← 0
LD     HL,#10H  ; HL ← 10H
ST     #5,@HL+  ; RAM [10H] ← 5, ← LR + 1
ST     #0FH,@HL+ ; RAM [11H] ← FH, LR ← LR + 1
```

Example 2: The output latch of R71 pin is set to "1" by the L register indirect addressing bit manipulation instruction.

```
LD     L,#1101B ; Sets R71 pin address to L register
SET    @L       ; R71 ← 1
```

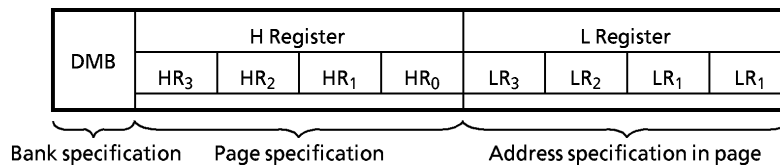

Figure 2-4. Configuration of H, L registers and DMB

## 2.4 Data Memory (RAM)

The data memory stores user-processed data. One page of this memory is 16 words long (1 word = 4 bits). It has 2 banks.

The data memory is addressed in one of three ways:

### (1) Register-indirect addressing mode

In this mode, a bank is specified by the DMB, a page by the H register and an address in the page by the L register.

```
Example: LD A,@HL ; Acc ← RAM[HL]
```

### (2) Direct addressing mode

An address in the bank is directly specified by the 8 bits of the second byte (operand) in the instruction field. The bank is specified by the DMB.

```
Example: LD A,2CH ; Acc ← RAM[2CH]
```

### (3) Zero-page addressing mode

An address in zero-page of bank 0 (addresses 00H through 0FH) by the lower 4 bits of the second byte (operand) in the instruction field.

```
Example: ST #3,05H ; RAM[05H] ← 3
```

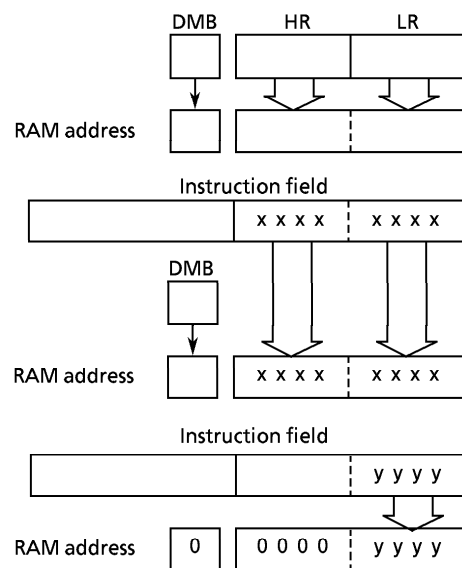

Figure 2-5. Addressing mode

### 2.4.1 Data memory map

Figure 2-6 shows the data memory map. The data memory is also used for the following special purposes: Note that this special function area is provided only on bank 0.

- ① Stack
- ② Stack pointer word (SPW)
- ③ Data counter (DC)
- ④ Count registers of the timer/counters (TC1, TC2)
- ⑤ Zero-page

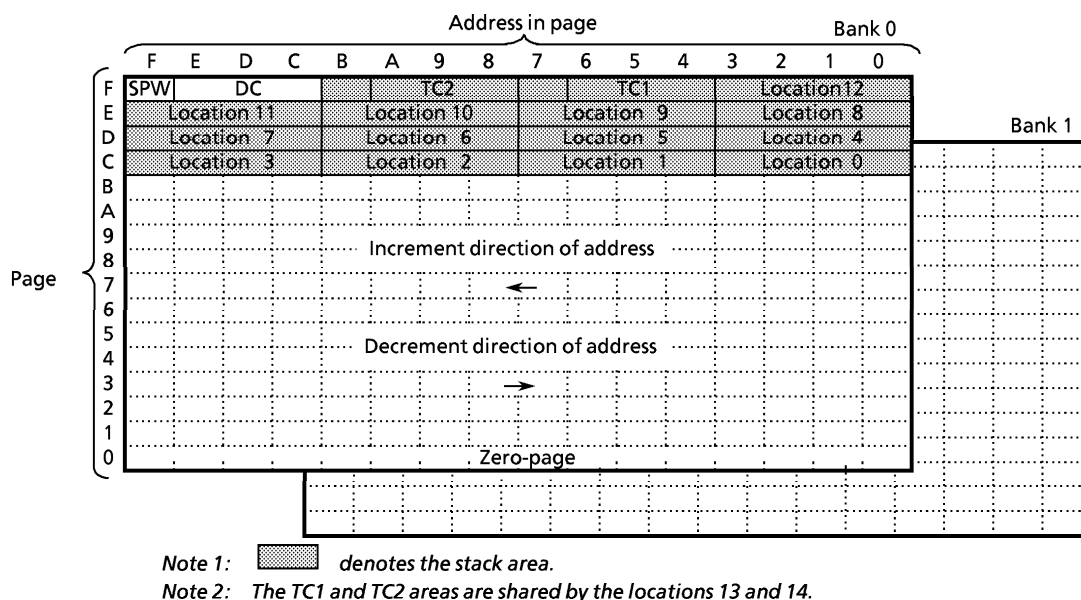

Figure 2-6. Data memory map

## (1) Stack

The stack provides the area in which the return address is saved before a jump is performed to the processing routine at the execution of a subroutine call instruction or the acceptance of an interrupt. When a subroutine call instruction is executed, the contents (the return address) of the program counter are saved; when an interrupt is accepted, the contents of the program counter and flags are saved.

When returning from the processing routine, executing the subroutine return instruction [RET] restores the contents of the program counter from the stack; executing the interrupt return instruction [RETI] restores the contents of the program counter and flags.

The stack consists of up to 15 levels (locations 0 through 14) which are provided in the bank 0 of data memory (addresses C0<sub>H</sub> through FB<sub>H</sub>). Each location consists of 4-word data memory. Locations 13 and 14 are shared by the count registers of the timer/counters (TC1, TC2) to be described later.

The save/restore locations in the stack are determined by the stack pointer word (SPW). The SPW is automatically decremented after save and incremented before restore. That is, the value of the stack pointer word indicates the stack location number for the next save.

## (2) Stack Pointer Word (SPW)

Address FF<sub>H</sub> in the data memory (bank 0) is called the stack pointer word, which identifies the location in the stack to be accessed (save or restore).

Generally, location number 0 to 12 can be set to the SPW, providing up to 13 levels of stack nesting. Locations 13 and 14 are shared by the count registers of the timer/counters to be described later; therefore, when the timer/counters are not used, the stack area of up to 15 levels is available. Address FF<sub>H</sub> is assigned with the SPW, so that the contents of the SPW cannot be set "15" in any case. The SPW is automatically updated when a subroutine call is executed or an interrupt is accepted. However, if it is used in excess of the stack area permitted by the data memory allocating configuration, the user-processed data may be lost. (For example, when the user-processed data area is in an address range 00<sub>H</sub> through CF<sub>H</sub>, up to location 4 of the stack are usable. If an interrupt is accepted with location 4 already used, the user-processed data stored in addresses CC<sub>H</sub> through CF<sub>H</sub> corresponding to the location 3 area is lost.)

The SPW is not initialized by hardware, requiring to write the initial value (the location with which the use of the stack starts) by using the initialization routine. Normally, the initial value of "12" is set to the SPW.

Example: To initialize the SPW (when the stack is used from location 12)

```
LD    A, #12
CLR   DMB           ; DMB←0H
ST    A, 0FFH      ; RAM[FF]←Acc
```

(3) Data counter (DC)

The data counter is a 12-bit register to specify the address of the data table to be referenced in the program memory (ROM). Data table reference is performed by the table look-up instructions [LDL A,@DC] and [LDH A,@DC+].

The data tables are set in the program memory area between addresses 1000<sub>H</sub> and 1FFF<sub>H</sub>.

The DC is assigned with a RAM address in unit of 4 bits.

Therefore, the RAM manipulation instruction is used to set the initial value or read the contents of the DC.

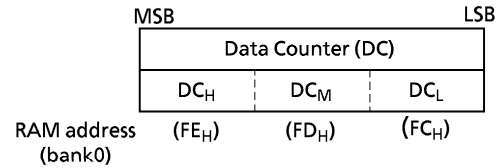

Figure 2-8. Data counter

Example: To set the DC to 780<sub>H</sub>

```
CLR   DMB           ; DMB←0
LD    HL, #0FCH     ; Sets RAM address of DC_L to HL register pair.
ST    #0H, @HL+    ; DC←780_H
ST    #8H, @HL+
ST    #7H, @HL+
```

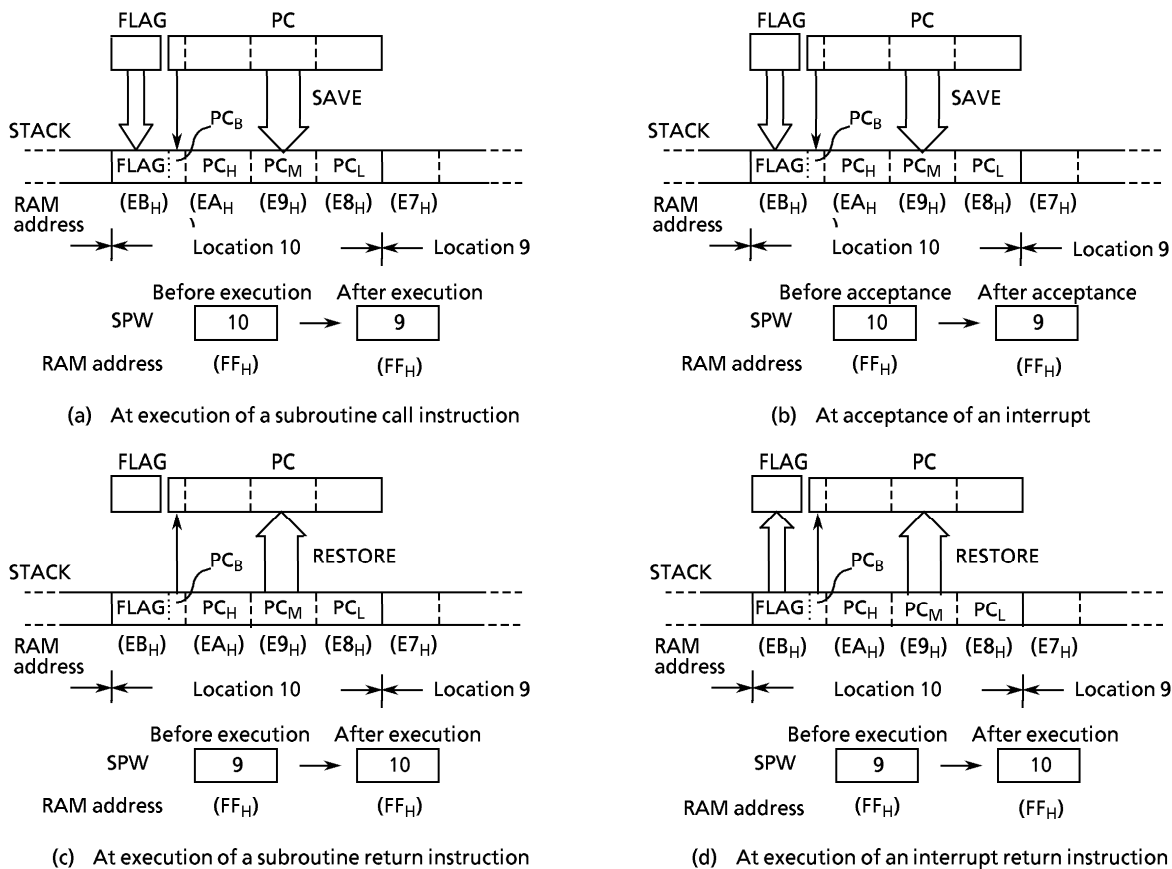

Figure 2-7. Accessing stack (Save/Restore)

(4) Count registers of the timer/counter (TC1, TC2)

The TMP47C660A/860A has two 12-bit timer/counters. The count register of the timer/counter is assigned with RAM addresses in unit of 4 bits, so that the initial value setting or contents reading is performed by using RAM manipulation instruction.

The count registers are shared by the stack area (locations 13 and 14) described earlier, so that the stack is usable from location 13 when the timer/counter 1 is not used. When none of timer/counter 1 and timer/counter 2 are used, the stack is usable from location 14.

When both timer/counter 1 and timer/counter 2 are used, the data memory (bank 0) locations at addresses F7<sub>H</sub> and FB<sub>H</sub> can be used to store the user-processed data.

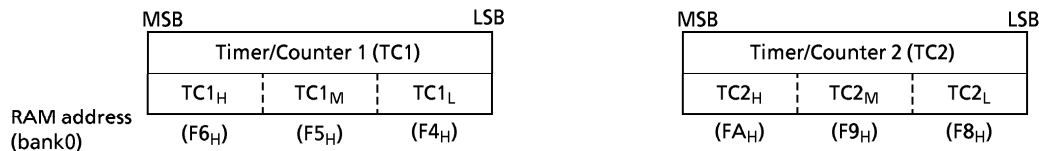

Figure 2-9. Count Registers of Timer/Counters (TC1,TC2)

(5) Zero - page

The 16 words (at addresses 00<sub>H</sub> through 0F<sub>H</sub>) of the page zero of the data memory (bank 0) can be used as the user flag or pointer by using zero-page addressing mode instructions (comparison, addition, transfer, and bit manipulation), providing enhanced efficiency in programming.

Example: To write "8" to address 09<sub>H</sub> if bit 2 at address 04<sub>H</sub> in the data memory (bank 0) is "1".

```
TEST    04H, 2    ; Skips if bit 2 at address 04H in the is "0".
B       SKIP
ST      #8, 09H   ; Writes "8" to address 09H in the RAM.
```

SKIP:

2.4.2 Data memory capacity

The TMP47C860A contains two 256 × 4 bit data memory banks (bank0 and bank1). The TMP47C660A contains 256 × 4 bit bank0 and 128 × 4 bit bank1. When power-on is performed, the contents of the data memory become unpredictable, so that they must be initialized by the initialize routine.

Example: To clear RAM

```
LD      HL, #00H
SCLR1: CLR    DMB
SCLR2: ST     #0, @HL+
B       SCLR2
SET     DMB
SCLR3: ST     #0, @HL+
B       SCLR3
ADD     H, #1
```

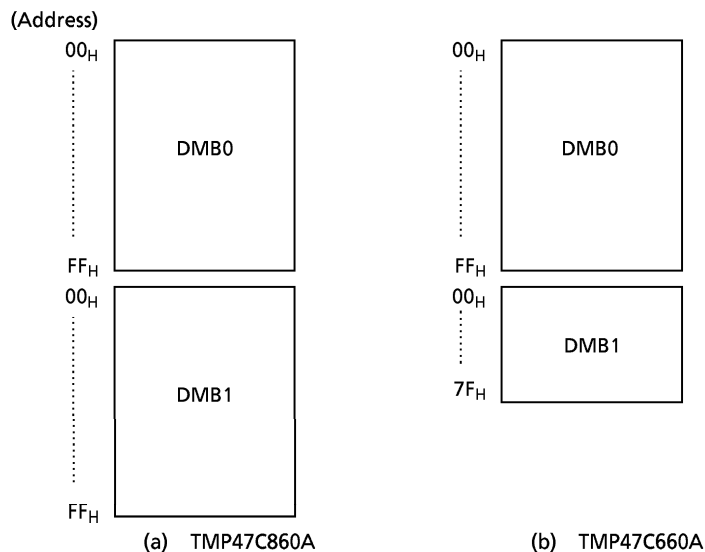

Note: When the TMP47P860V is used as evaluator of the TMP47C860A, the data should not be written after address 80<sub>H</sub> of bank1.

Figure 2-10. Data memory (RAM)

## 2.5 ALU and Accumulator

### 2.5.1 Arithmetic / Logic Unit (ALU)

The ALU performs the arithmetic and logic operations specified by instructions on 4-bit binary data and outputs the result of the operation, the carry information (C), and the zero detect information (Z).

#### (1) Carry information (C)

The carry information indicates a carry-out from the most significant bit in an addition. A subtraction is performed as addition of two's complement, so that, with a subtraction, the carry information indicates that there is no borrow to the most significant bit. With a rotate instruction, the information indicates the data to be shifted out from the accumulator.

#### (2) Zero detect information (Z)

This information is "1" when the operation result or the data to be transferred to the accumulator/data memory is "0000<sub>B</sub>".

Example: The carry information (C) and zero detect information (Z) for 4-bit additions and subtractions.

Operation	Result	C	Z
4 + 2 =	6	0	0
7 + 9 =	0	1	1
8 - 1 =	7	1	0
2 - 2 =	0	1	1
5 - 8 =	-3 (1101 <sub>B</sub> )	0	0

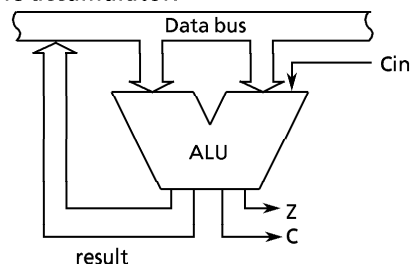

Note: Cin indicates the carry input specified by instruction.

Figure 2-11. ALU

### 2.5.2 Accumulator (Acc)

The accumulator is a 4-bit register used to hold source data or results of the operations and data manipulations.

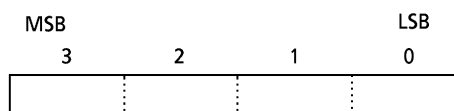

Figure 2-12. Acc

## 2.6 Flags

There are a carry flag (CF), a status flag (SF), and zero flag (ZF), each consisting of 1 bit. These flags are set or cleared according to the condition specified by an instruction. When an interrupt is accepted, the flags are saved on the stack along with the program counter. When the [RETI] instruction is executed, the flags are restored from the stack to the states set before interrupt acceptance.

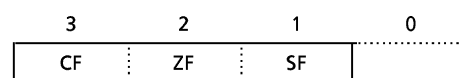

Figure 2-13. Flag

#### (1) Carry flag (CF)

The carry flag holds the carry information received from the ALU at the execution of an addition/subtraction with carry instruction, a compare instruction, or a rotate instruction. With a carry flag test instruction, the CF holds the value specified by it.

- ① Addition/subtraction with carry instructions [ADDC A,@HL], [SUBRC A,@HL]

The CF becomes the input (Cin) to the ALU to hold the carry information.

- ② Compare instructions [CMPR A,@HL], [CMPR A,#k]

The CF holds the carry information (non-borrow).

- ③ Rotate instructions [ROLC A], [RORC A]

The CF is shifted into the accumulator to hold the carry information (the data shifted out from the accumulator).

## ④ Carry flag test instructions [TESTP CF], [TEST CF]

With [TESTP CF] instruction, the content of the CF is transferred to the SF then the CF is set to "1".

With [TEST CF] instruction, the value obtained by inverting the content of the CF is transferred to the SF then the CF is cleared to "0".

## (2) Zero flag (ZF)

The zero flag holds the zero detect information (Z) received from the ALU at the execution of an operational instruction, a rotate instruction, an input instruction, or a transfer-to-accumulator instruction.

## (3) Status flag (SF)

The SF provides the branch condition for a branch instruction. Branch is performed when the SF is set to "1". Normally the SF is set to "1", so that any branch instruction can be regarded as an unconditional branch instruction. When a branch instruction is executed upon set or clear of the SF according to the condition specified by instruction, this instruction becomes a conditional branch instruction. During reset, the SF is initialized to "1", other flags are not affected.

Example: When the following instructions are executed with the accumulator, H register, L register, data memory address 07<sub>H</sub>, and carry flag are "C<sub>H</sub>", "0<sub>H</sub>", "7<sub>H</sub>", "5<sub>H</sub>", and "1" respectively, the contents of the accumulator and flags become as follows:

Instruction	Acc after execution	Flag after execution		
		CF	ZF	SF
ADDC A, @HL	2 <sub>H</sub>	1	0	0
SUBRC A, @HL	9 <sub>H</sub>	0	0	0
CMPR A, @HL	C <sub>H</sub>	0	0	1
AND A, @HL	4 <sub>H</sub>	1	0	1
LD A, @HL	5 <sub>H</sub>	1	0	1

Instruction	Acc after execution	Flag after execution		
		CF	ZF	SF
LD A, #0	0 <sub>H</sub>	1	1	1
ADD A, #4	0 <sub>H</sub>	1	1	0
DEC A	B <sub>H</sub>	1	0	1
ROL A	9 <sub>H</sub>	1	0	0
ROR A	E <sub>H</sub>	0	0	1

## 2.7 Clock Generator, Timing Generator, and System Clock Controller

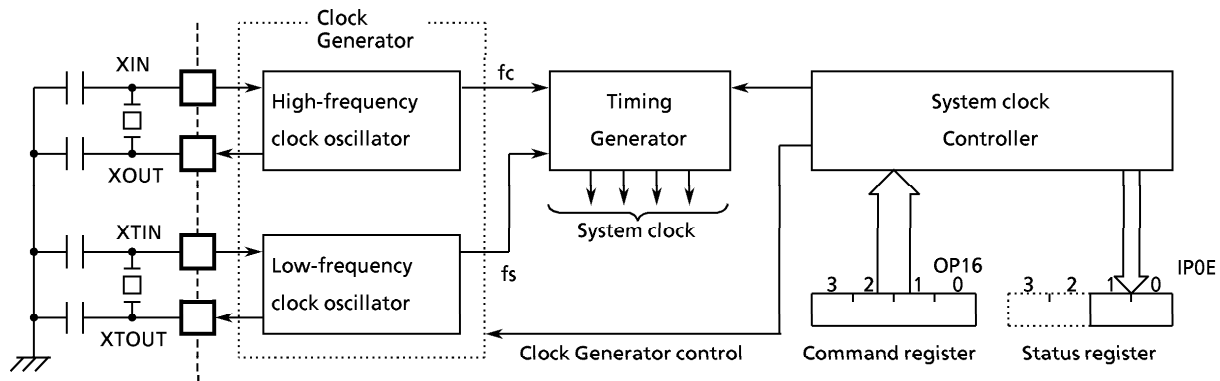

Figure 2-14. Clock generator, timing generator and system clock controller

### 2.7.1 Clock Generator (CG)

The clock generator produces the basic clock pulses which provide the system clock to be supplied to the CPU and peripheral hardware. It contains two oscillators: a high-frequency clock oscillator and a low-frequency clock oscillator. Power consumption can be reduced by switching to the low power operation based on the low-frequency clock by the system clock controller. The high-frequency clock and the low-frequency clock can be easily obtained by attaching a resonator between the XIN and XOUT pins and the XTIN and XTOUT pins, respectively. The system clock can also be obtained from the external oscillator.

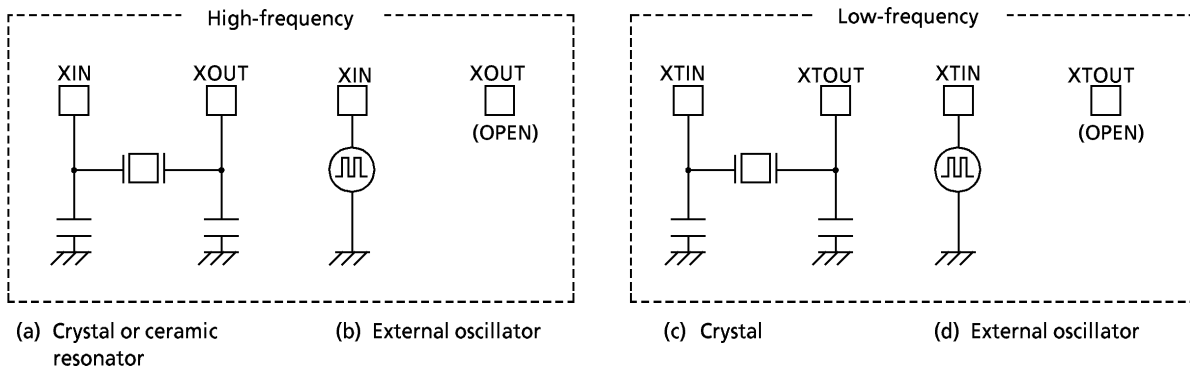

Figure 2-15. Examples of resonator connection

**Note:** Accurate adjustment of the oscillation frequency

Although no hardware to externally and directly monitor the clock pulse is not provided, the oscillation frequency can be adjusted by making the program to output the pulse with a fixed frequency to the port with the all interrupts disabled and timer/counters stopped and monitoring this pulse. With a system requiring the oscillation frequency adjustment, the adjusting program must be created beforehand.

**Example:** To adjust the low-frequency oscillation frequency by outputting monitor pulse to R70 pin. (Before executing the program, make sure that MCU outputs the stable low-frequency clock oscillation in SLOW mode.)

```
SFCCHK: SET    %OP07, 0
        CLR    %OP07, 0
        BSS    SFCCHK
```

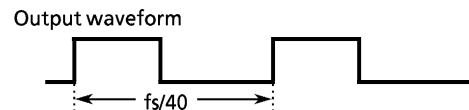

## 2.7.2 Timing generator (TG)

### (1) Configuration of timing generator

The timing generator produces the system clocks from clock pulse which are supplied to the CPU and peripheral hardware.

The timing generator consists of a 19-stage binary counter with a divide-by-8 prescaler. The source clock to the timing generator and its input stage depend on the operating mode as shown below.

During reset, the binary counter is cleared to "0". However, the prescaler is not cleared.

#### ① Single-clock mode

The high-frequency clock ( $f_c$ ) is input to the first stage of the timing generator. In this mode, it is necessary to clear SCLK (bit 2 of command register OP16) to "0".

#### ② Dual-clock mode

In this mode,  $f_c$  is input to the first stage and the 7th stage and the 8th stage are separated. The SCLK (bit 2 of command register OP16) can select the input clock for the 8th stage. Setting the SCLK inputs  $f_s$  and clearing the SCLK inputs  $f_c/2^7$ . In SLOW mode, the high-frequency clock oscillation is stopped. Thus  $f_s$  is automatically input to the 8th stage and the outputs from the first stage to the 7th stage are stopped.

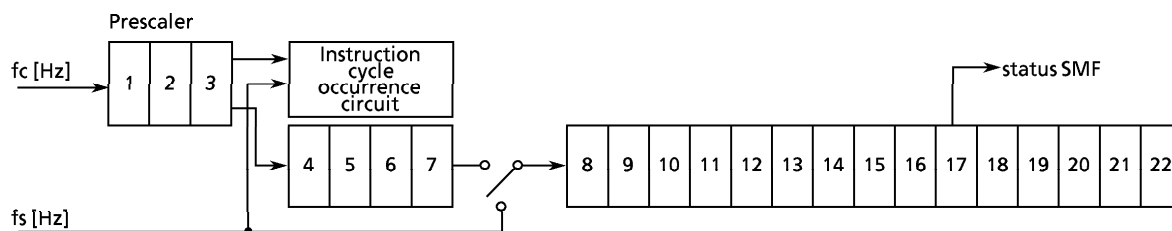

Figure 2-16. Configuration of timing generator

### (2) The timing generator provides the following functions:

- |                                     |   |
|-------------------------------------|---|
| ① Instruction cycle                 | ④ Internal serial clock for a serial interface  |
| ② Internal pulse for interval timer | ⑤ Warm-up time at release of the hold operation |
| ③ Internal pulse for timer/counters | ⑥ Source clock for a watchdog timer             |



### 2.7.3 System clock controller

The system clock controller starts or stops the high-frequency and low-frequency clock oscillator and switches between the basic clocks. The operating mode is generally divided into the single-clock mode and the dual-clock mode, which are controlled by command.

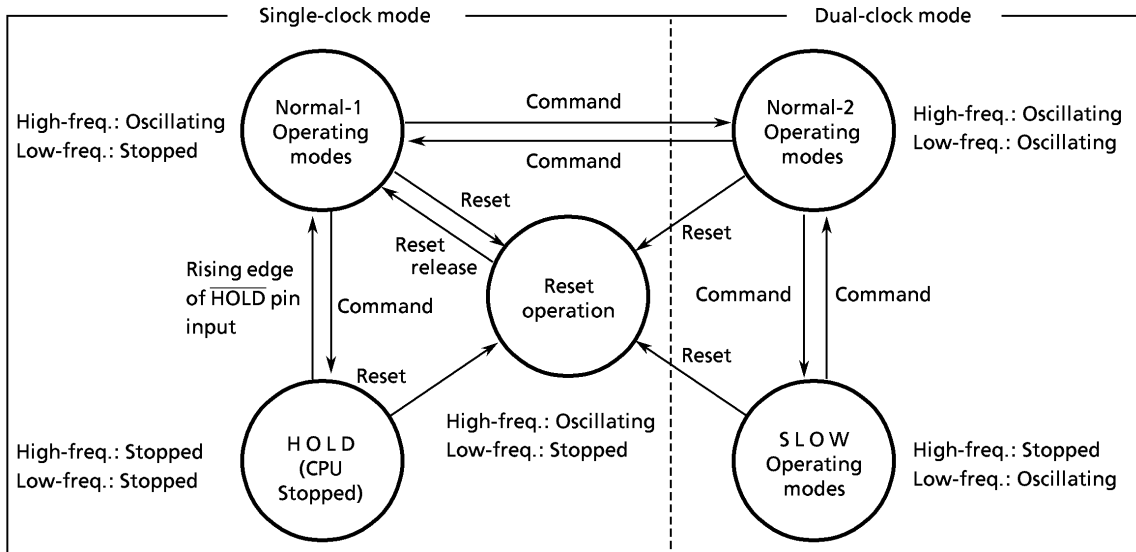

Figure 2-17. Operating mode transition diagram

*Note: Normal-1 and Normal-2 operating modes are sometimes referred to as the Normal operating mode collectively.*

(1) System clock control

System clock control is performed by the command register (OP16). During reset, this register is initialized to "0" and the single-clock mode is selected.

Each state at operating mode switching can be read from the status register (IP0E).

System clock control command register

(Port address: OP16) (Initial value: 0000)

3	2	1	0
DCLK3	SLCK	DCLK1	DWUT

DCLK3 / DCLK1 Selects operation mode (Note 2)

- 00: Single clock mode (Normal-1 operating mode)
- 01: Reserved
- 10: Dual clock mode (Normal-2 operating mode)
- 11: Dual clock mode (SLOW operating mode)

SLCK Selects input clock for the eighth stage of TG (Note 3)

Example:  $f_c = 4.19 \text{ MHz}$

- 0:  $f_c/2^7$  [Hz] ..... 32.8 [kHz]
- 1:  $f_s$

DWUT Sets the warm-up time (Note 4)

Example: At  $f_c = 4.19 \text{ MHz}$   
 $f_s = 32.8 \text{ kHz}$

- 0:  $2^8/f_s + 2^9/f_c$  [s] ..... 7.9 [ms]
- 1:  $2^{11}/f_s + 2^9/f_c$  ..... 62.6

System clock control status register

(Port address: IP0E)

3	2	1	0
(SIOF)	(SEF)	SMF	HOLD/SLS

SMF Low-frequency clock oscillating

- 0: Not oscillating or unstable oscillation
- 1: Stable oscillation

HOLD / SLS  $\overline{\text{HOLD}}$  pin state/operation state monitor

- 0:  $\overline{\text{HOLD}}$  pin at "H" level In Normal operation
- 1:  $\overline{\text{HOLD}}$  pin at "L" level In SLOW operation

Note 1:  $f_c$ ; High-frequency clock [Hz]

$f_s$ ; Low-frequency clock [Hz]

Note 2: Configuration of bits.

Note 3: Only Normal-2 operating mode

Note 4: Only switching from SLOW to Normal-2

Note 5: The access to command register (OP16) may cause the outputs over the eighth stage of timing generator to precede that to be expected by maximum  $2^7/f_c$  or  $1/f_s$  [s].

Figure 2-18. System clock control command register / status register

(2) Instruction cycle

The instruction execution and on-chip peripheral hardware operations are performed in synchronization with the basic clock. The smallest unit of instruction execution is called the "instruction cycle". The TLC5-470 series instruction set has 3 kinds of instructions, 1-cycle instruction to 3-cycle instruction. Each instruction cycle consists of 4 states (S1 through S4). Each state consists of 2 basic clock pulses.

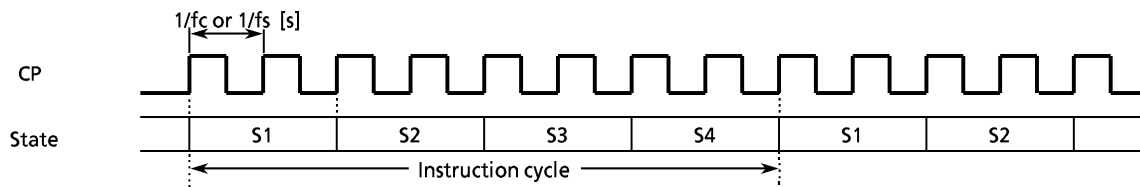

Figure 2-19. Instruction cycle

## 2.7.4 Operation mode

### (1) Dual-clock mode

In this mode, the Normal-2 operation is generally performed by generating the system clock from the high-frequency clock (fc). As required, the SLOW operation can be performed by generating the system clock from the low-frequency clock (fs).

The following describes the switching between the Normal-2 and SLOW operations in the dual clock mode. During reset, the command register is initialized to the single-clock mode.

Since the low-frequency clock is not oscillated, Normal-2 operation in the dual clock mode must be set first. The low-frequency clock starts oscillating by transferring to Normal-2 operation.

#### a. Switching from Normal-2 operation to SLOW operation

Setting DCLK1 (bit 1 of OP16) to "1" switches Normal-2 operation to SLOW operation. However it takes a few seconds to get a stable oscillation, the low-frequency clock. Therefore if there is possible to switch from Normal-2 operation to SLOW operation, wait until the low-frequency clock is stable or check the oscillation state by a program.

SMF status (bit 1 of IP0E) is available to check it.

When the high-frequency clock (fc/2<sup>7</sup>) is input to the 8th stage of TG, first sets SCLK (bit 2 OP16) to "1" and input the low-frequency clock (fs).

SMF (bit 1 of the status register) is monitored by program. First, Sets SLCK (bit 2 of OP16) to "1". Next, when it has been confirmed that the low-frequency clock oscillation is stable and SMF is changed "1"→"0"→"1" or "0"→"1"→"0", bit 2 of the command register is set to "1". At this time, the high-frequency clock oscillator stops.

#### b. Returning from SLOW operation to Normal-2 operation

Bit 2 of the command register is cleared to "0" and, at the same time, the warm-up time for return is set to DWUT. When the warm-up time has passed, the Normal-2 operation takes place. By monitoring SLS (bit 0 of the status register), the current operating mode can be known.

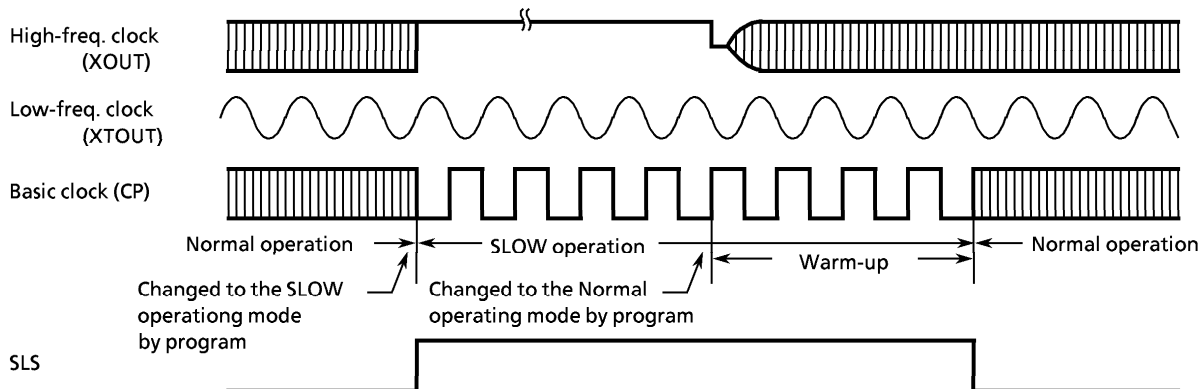

Figure 2-20. System clock switching timing

**Note:** In the SLOW operating mode, the power consumed by the oscillator and the internal hardware is reduced. However, the power for the pin interface (depending on the external circuitry and program) is not directly associated with the low-power consumption operation. This must be considered in system design as well as interface circuit design.

### (2) Single-clock mode

In this mode, only the high-frequency clock oscillator is used. Pins R72 (XTIN) and R73 (XTOUT) become the ordinary I/O port. The HOLD operating mode is available for reducing power consumption. It is controlled by the command register (OP10). In this mode, therefore, the system clock control command register (OP16) need not be manipulated. For the details of the HOLD operation, refer to Subsection "2.7.5 HOLD Operating Mode".

### 2.7.5 HOLD operating mode

The HOLD feature stops the system and holds the system's internal states active before stop with a low power. The HOLD operation is controlled by the command register (OP10) and the  $\overline{\text{HOLD}}$  pin input. The  $\overline{\text{HOLD}}$  pin input state can be known by the status register (IP0E). The  $\overline{\text{HOLD}}$  pin is shared by the  $\overline{\text{KE0}}$  pin.

#### (1) Starts the HOLD operating mode

The HOLD operating mode when the command is set and holds the following states during the HOLD operation:

- ① Oscillator stops and the system's internal operations are all held up.
- ② The interval timer is cleared to "0".
- ③ The states of the data memory, registers, and latches valid immediately before the system is put in the HOLD state are all held.
- ④ The program counter holds the address of the instruction to be executed after the instruction [out A, %OP10] or [OUT @HL, %OP10] which starts the HOLD operating mode.

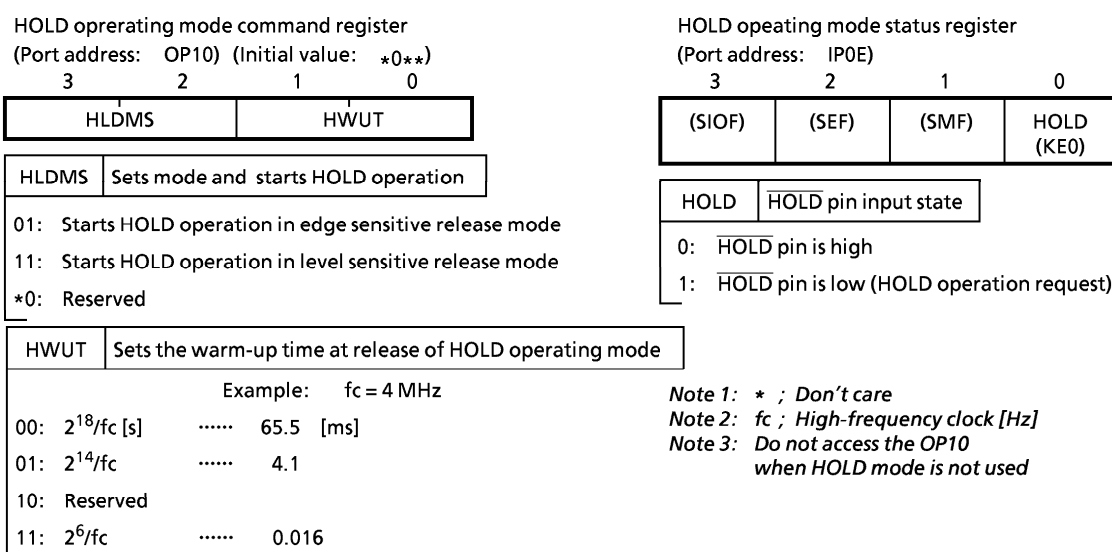

Figure 2-21. HOLD operating mode command register/status register

The HOLD operating mode consists of the level-sensitive release mode and the edge-sensitive release mode.

#### a. Level-sensitive release mode

In this mode, the HOLD operating is released by setting the  $\overline{\text{HOLD}}$  pin to the high level. This mode is used for the capacitor backup with the main power off or for the battery backup for long hours.

If the instruction to start the HOLD operation is executed with the  $\overline{\text{HOLD}}$  pin input being high, the HOLD operation does not start but the clear sequence (warm-up) sets in immediately. Therefore, to start the HOLD operation in the level-sensitive mode, that the  $\overline{\text{HOLD}}$  pin input is low (the HOLD operation request) must be recognized in program. This recognition is one of the two ways below:

- ① Testing  $\overline{\text{HOLD}}$  (bit 0 of the status register)
- ② Applying the  $\overline{\text{HOLD}}$  pin input also to the  $\overline{\text{INT1}}$  pin to generate the external interrupt 1 request.

Example: To test  $\overline{\text{HOLD}}$  to start the HOLD operation in the level-sensitive release mode (the warm-up time =  $2^{14}/f_c$ ).

```
SHOLDH: TEST  %IP0E, 0      ; Waits until  $\overline{\text{HOLD}}$  pin input goes low.
         B      SHOLDH
         LD    A, #1101B    ; OP10 ← 1101B
         OUT  A, %OP10
```

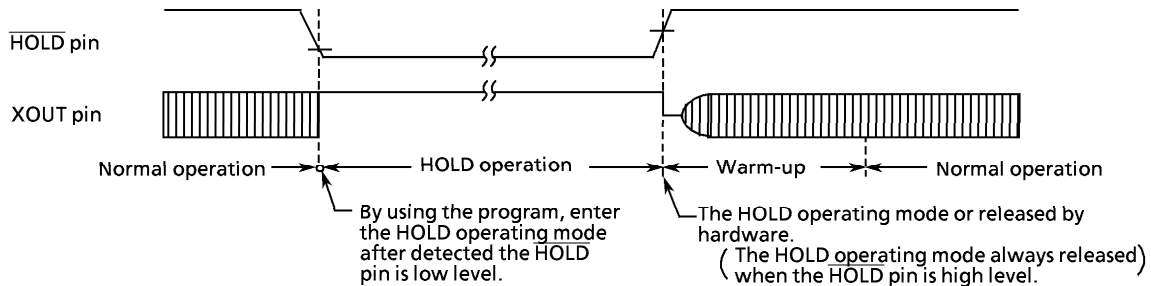

Figure 2-22. Level-sensitive release mode

b. Edge-sensitive release mode

In this mode, the HOLD operation is released at the rising edge of the  $\overline{\text{HOLD}}$  pin input. This mode is used for applications in which a relatively short time program processing is repeated at a certain cycle. This cyclic signal (for example, the clock supplied from the low power dissipation oscillator). In the edge-sensitive release mode, even if the  $\overline{\text{HOLD}}$  pin input is high, the HOLD operation is performed.

Example: To start the HOLD operation in the edge-sensitive release mode (the warm-up time =  $2^{14}/f_c$ ).

```
LD    A, #0101B      ; OP10 ← 0101B
OUT  A, %OP10
```

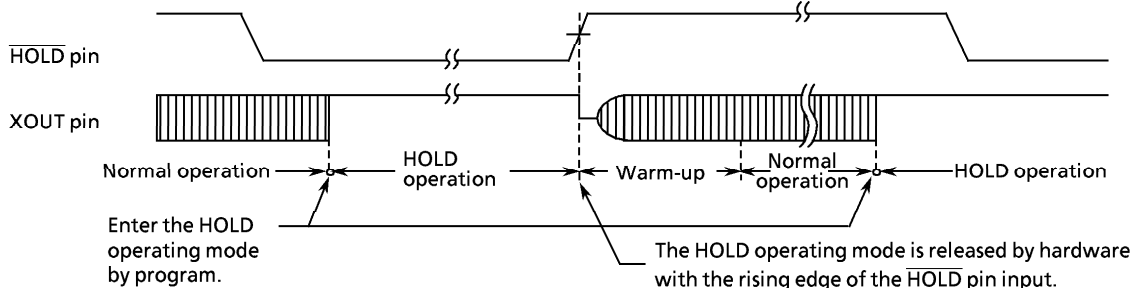

Figure 2-23. Edge-sensitive release mode

**Note:** In the HOLD operation, the dissipation of the power associated with the oscillator and the internal hardware is lowered; however, the power dissipation associated with the pin interface (depending on the external circuitry and program) is not directly determined by the hardware operation of the HOLD feature.

This point should be considered in the system design and the interface circuit design. In the CMOS circuitry, little current flows when the input level is stable at the power voltage level ( $V_{DD}/V_{SS}$ ); however, when the input level gets higher than the power voltage level (by approximately 0.3 to 0.5 V), a current begins to flow. Therefore, if cutting off the output transistor at an I/O port (the open drain output pin with an input transistor connected) puts the pin signal into the high-impedance state, a current flow across the port's input transistor, requiring to fix the level by pull-up or other means.

## (2) Releases the HOLD operating mode

The HOLD operating mode is released in the following sequence:

- ① The high-freq. oscillator starts.
  - ② Warm-up is performed to acquire the time for stabilizing oscillation. During the warm-up, the internal operations are all stopped. One of three warm-up times can be selected by program depending on the characteristics of the oscillator used.
  - ③ When the warm-up time has passed, an ordinary operation restarts from the instruction next to instruction which starts the HOLD operation. At this time, the interval timer starts from the reset state "0".
- \* The warm-up time is obtained by dividing the basic clock by the interval timer, so that, if the frequency at clearing the HOLD operation is unstable, the warm-up time shown in Figure 2-21 includes an error. Therefore, the warm-up time must be handled as an approximate value.

The HOLD operation is also released by setting the  $\overline{\text{RESET}}$  pin to the low level. In this case, the normal reset operation follows immediately.

**Note:** To release the HOLD operation at a low hold voltage, the following points must be considered:

To release the HOLD operation, the power voltage needs to be raised to the operating voltage level. If this is done, the  $\overline{\text{RESET}}$  pin input, which is at the high level, also rises with the power voltage. In this case, if a time constant circuit or the like is externally attached, the rise of the  $\overline{\text{RESET}}$  pin input voltage goes behind the rise of the power voltage. At this time, if the voltage level of the  $\overline{\text{RESET}}$  pin input drops below the non-inverted high level input voltage of the  $\overline{\text{RESET}}$  pin input (hysteresis input), the reset operation may occur.

## 2.8 Interrupt Function

## (1) Interrupt controller

There are 6 interrupt sources (2 external and 4 internal).

The prioritized multiple interrupt capability is supported.

The interrupt latches (IL<sub>5</sub> through IL<sub>0</sub>) to hold interrupt requests are provided for the interrupt sources. Each interrupt latch is set to "1" when an interrupt request is made, asking the CPU to accept the interrupt. The acceptance of interrupt can be permitted or prohibited by program through the interrupt enable master flip-flop (EIF) and interrupt enable register (EIR). When two or more interrupts occurs simultaneously, the one with the highest priority determined by hardware is serviced first.

Table 2-2. Interrupt sources

Sources		Priority	Interrupt latch	Permit conditions by program	Entry address
External	External interrupt 1 (INT1)	(High rank) 1	IL <sub>5</sub>	EIF = 1	0002 <sub>H</sub>
Internal	Serial interface interrupt (ISIO)	2	IL <sub>4</sub>	EIF = 1, EIR <sub>3</sub> = 1	0004 <sub>H</sub>
	Timer/Counter 1 overflow interrupt (IOVF1)	3	IL <sub>3</sub>	EIF = 1, EIR <sub>2</sub> = 1	0006 <sub>H</sub>
	Timer/Counter 2 overflow interrupt (IOVF2)	4	IL <sub>2</sub>	EIF = 1, EIR <sub>1</sub> = 1	0008 <sub>H</sub>
	Interval timer interrupt (ITMR)	5	IL <sub>1</sub>		000A <sub>H</sub>
External	External interrupt 2 (INT2)	(Low rank) 6	IL <sub>0</sub>	EIF = 1, EIR <sub>0</sub> = 1	000C <sub>H</sub>

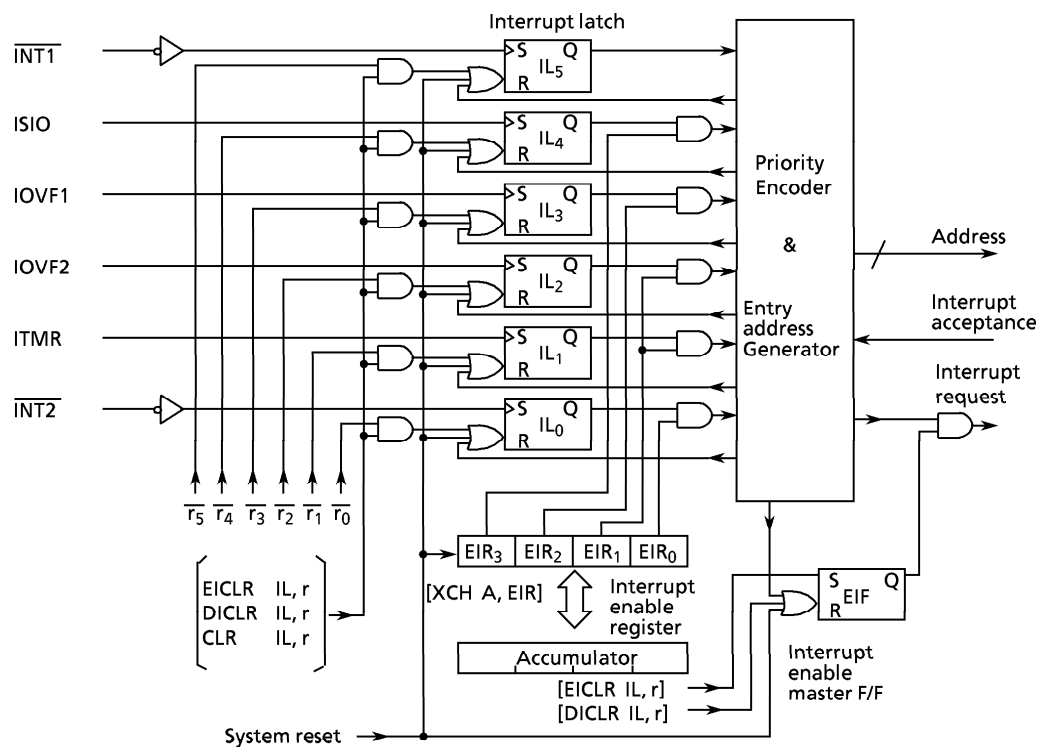

Figure 2-24. Interrupt controller block diagram

a. Interrupt enable master flip-flop (EIF)

The EIF controls the enable/disable of all interrupts. When this flip-flop is cleared to "0", all interrupts are disabled; when it is set to "1", the interrupts are enabled.

When an interrupt is accepted, the EIF is cleared to "0", temporarily disabling the acceptance of subsequent interrupts.

When the interrupt service program has been executed, the EIF is set to "1" by the execution of the interrupt return instruction [RETI], being put in the enabled state again.

Set or clear of the EIF in program is performed by instructions [EICLR IL,r] and [DICLR IL,r], respectively. The EIF is initialized to "0" during reset.

b. Interrupt enable register (EIR)

The EIR is a 4-bit register specifies the enable or disable of each interrupts except INT1. An interrupt is enabled when the corresponding bit of the EIR is "1", an interrupt is disabled when the corresponding bit of the EIR is "0". Bit 1 (EIR<sub>1</sub>) of the EIR is shared by both IOVF2 and ITMR interrupts.

Read/write on the EIR is performed by executing [XCH A,EIR] instruction. The EIR is initialized to "0" during reset.

c. Interrupt latches (IL)

An interrupt latch is provided for each interrupt source. It is set to "1" when an interrupt request is made to ask the CPU for accepting the interrupt. Each latch is cleared to "0" upon acceptance of the interrupt. It is initialized to "0" during the reset.

The interrupt latches can be cleared independently by interrupt latch operation instructions ([EICLR IL,r], [DICLR IL,r], and [CLR IL,r]) to make them cancel interrupt requests or initialize by program. When the value of instruction field(r) is "0", the interrupt latch is cleared; when the value is "1", the IL is held. Note that the interrupt latches cannot be set by instruction.

Example 1: To enable IOVF1, INT1, and INT2

```
LD      A,  #0101B      ; EIR ← 0101B
XCH    A,  EIR
EICLR  IL,  111111B    ; EIF ← 1
```

Example 2: To set the EIF to "1" and to clear the interrupt latches except ISIO to "0".

```
EICLR  IL,  010000B    ; EIF ← 1, IL5 ← 0, IL3-IL0 ← 0
```

## (2) Interrupt processing

An interrupt request is held until the interrupt is accepted or the IL is cleared by reset or the interrupt latch operation instruction. The interrupt acknowledge processing is performed in 2 instruction cycles after the end of the current instruction execution (or after the timer/counter processing if any). The interrupt service program terminates upon execution of the interrupt return instruction [RETI].

The interrupt acknowledge processing consists of the following sequence:

- ① The contents of the program counter and the flags are saved on the stack.
- ② The interrupt entry address corresponding to the interrupt source is set to the program counter.
- ③ The status flag is set to "1".
- ④ The EIF is cleared to "0", temporarily disabling the acceptance of subsequent interrupts.
- ⑤ The IL for the accepted interrupt source is cleared to "0".
- ⑥ The instruction stored at the interrupt entry address is executed. (Generally, in the program memory space at the interrupt entry address, the branch instruction to each interrupt processing program is stored. Note that the interrupt entry address is assigned every 2-byte, so that the long branch instruction can not be stored in the program normally. The interrupt service program is assigned to the memory locations 0000<sub>H</sub> through 0FFF<sub>H</sub>.)

To perform the multi-interrupt, EIF is set to "1" in the interrupt service program, and the acceptable interrupt source is selected by the EIR. However, for the INT1 interrupt, the interrupt service is disabled under software control because it is not disabled by the EIR.

Example: The INT1 interrupt service is disabled under software control (Bit 0 of RAM [05<sub>H</sub>] are assigned to the disabled switch of interrupt service).

```
PINT1: TEST  05H, 0      ; If RAM [05H]0 = 1, returns without the interrupt service
          B    SINT1
          RETI
SINT1:   :
```



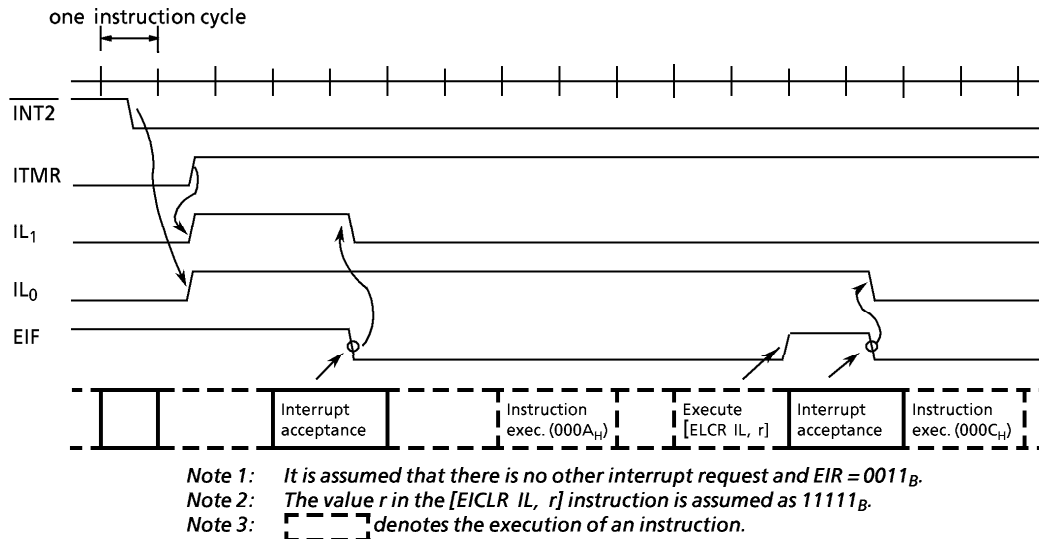

Figure 2-25. Interrupt timing chart (Example)

The interrupt return instruction [RETI] performs the following operations:

- ① Restores the contents of the program counter and the flags from the stack.
- ② Sets the EIF to "1" to provide the interrupt enable state again.

**Note:** When the time required for the interrupt service is longer than that for the interrupt request, only the interrupt service program is executed without executing the main program.

In the interrupt processing, the program counter and flags are automatically saved or restored but the accumulator and other registers (H or L register, DMB, DC, etc.) are not. If it is necessary to save or restore them, it must be performed by program as follows for example. To perform the multi-interrupt, the saving RAM area never be overlapped.

Example 1: To save/restore accumulator and HL register pair.

```
XCH  HL, GSAV1 ; RAM[GSAV1] ↔ HL
XCH  A, GSAV1 + 2 ; RAM[GSAV1 + 2] ↔ Acc
```

**Note:** The lower 2 bits of GSAV1 should be "0's".

Example 2: To save DMB to bit 0 of address GSAV3 in the RAM.

```
CLR  GSAV3, 0 ; RAM[GSAV3] 0 ← 0
TEST DMB ; If DMB = 0 then skip
B    SKIPS
SET  GSAV3, 0 ; RAM[GSAV3] 0 ← 1
```

SKIPS:

Example 3: Restore DMB from bit 0 of address GSAV3 in the RAM.

```
CLR  DMB ; DMB ← 0
TEST GSAV3, 0 ; If RAM [GSAV3] 0 = 0 then skip
B    SKIPR
SET  DMB ; DMB ← 1
```

SKIPR:

## (3) External interrupt

When an external interrupt (INT1 or INT2) occurs, the interrupt latch is set at the falling edge of the corresponding pin input ( $\overline{\text{INT1}}$  or  $\overline{\text{INT2}}$ ). The INT1 interrupt cannot be disabled by the EIR, so that it is always accepted in the interrupt enable state (EIF = "1"). Therefore, INT1 is used for an interrupt with high priority such as an emergency interrupt. When R82 ( $\overline{\text{INT1}}$ ) pin is used for the I/O port, the INT1 interrupt occurs at the falling edge of the pin input, so that the interrupt return [RET1] instruction must be stored at the interrupt entry address to perform dummy interrupt processing.

The INT2 interrupt can be enabled/disabled by the EIR.

Therefore, the INT2 interrupt occurs at the falling edge of the pin input when R80 ( $\overline{\text{INT2}}$ ) pin is used for the I/O port.

But bit 0 of the EIR is only kept at "0" not accepting the interrupt request.

Because the external interrupt input is the hysteresis type, each of high and low level operation requires 2 or more instruction cycles for a correct interrupt operation.

## 2.9 Reset Function

When the  $\overline{\text{RESET}}$  pin is held to the low level for at 3 or more instruction cycles when the power voltage is within the operating voltage range and the oscillation is stable, reset is performed to initialize the internal states.

When the  $\overline{\text{RESET}}$  pin input goes high, the reset is cleared and program execution starts from address 000<sub>H</sub>.

The  $\overline{\text{RESET}}$  pin is a hysteresis input with a pull-up resistor (220 k $\Omega$  typ.). Externally attaching a capacitor and a diode implement a simplified power-on-reset.

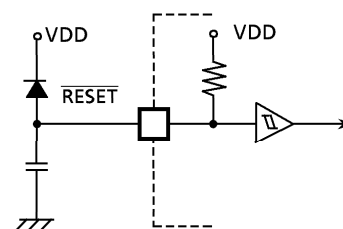

Figure 2-26. Simplified power-on-reset circuit

Table 2-3. Initialization of internal states by reset action

On-chip hardware	Initial value	On-chip hardware	Initial value
Program counter (PC)	0000 <sub>H</sub>	Interval timer	"0"
Status flag (SF)	1	Output latch (I/O port or output ports)	Refer to "I/O circuitry"
Data memory bank selector (DMB)	0	Command register	Refer to the description of each relative command register.
Interrupt enable master flip-flop (EIF)	0		
Interrupt enable register (EIR)	0 <sub>H</sub>		
Interrupt latch (IL)	"0"		

### 2.9.1 Warm-start

The warm-start capability to hold the data memory contents in the reset operation is not supported by hardware. However, it can be implemented by the following measures:

- ① Back up the voltage to be supplied to VDD pin.
- ② Apply to the  $\overline{\text{HOLD}}$  pin the waveform synchronized with the power voltage variation.
- ③ Set the HOLD operating mode during the power is off.
- ④ Perform reset by using the output port of sink open drain (initial "Hi-Z") after releasing HOLD operation.
- ⑤ Apply to an input port the power-on detect signal, and skip the initialize routines such as clearing RAM.

Figure 2-27 shows Warm-start Circuit Example

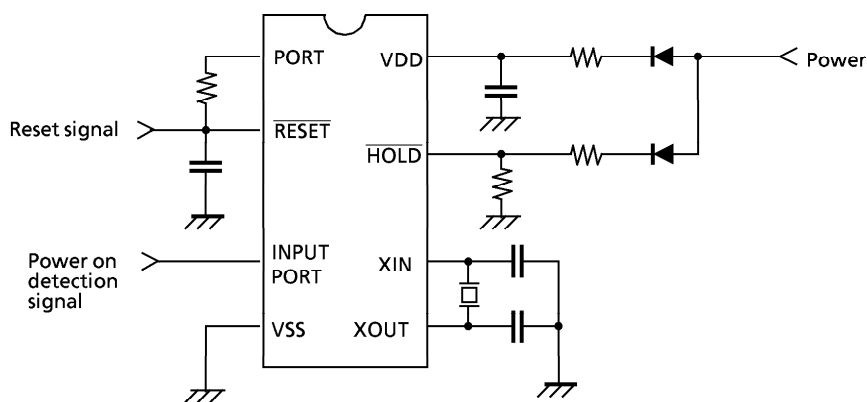

Figure 2-27. Warm-start circuit example

### 3. Peripheral Hardware Function

#### 3.1 Ports

The data transfer with the external circuit and the command/status/data transfer with the internal circuit are performed by using the I/O instructions (13 kinds). There are 4 types of ports:

- ① I/O port ; Data transfer with external circuit
- ② Command register ; Control of internal circuit
- ③ Status register ; Reading the status signal from internal circuit
- ④ Data register ; Data transfer with internal circuit

These ports are assigned with port addresses (00<sub>H</sub> through 1F<sub>H</sub>). Each port is selected by specifying its port address in an I/O instruction. Table 3-1 lists the port address assignments and the I/O instructions that can access the ports.

#### 3.1.1 I/O timing

##### (1) Input timing

External data is read from an input port or an I/O port in the S3 state of the second instruction cycle during the input instruction (2-cycle instruction) execution. This timing cannot be recognized from the outside, so that the transient input such as chattering must be processed by program.

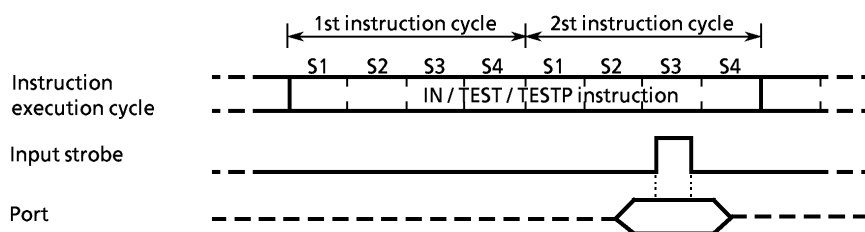

Figure 3-1. Input timing

##### (2) Output timing

Data is output to an output port or an I/O port in the S4 state of the second instruction cycle during the output instruction (2-cycle instruction) execution.

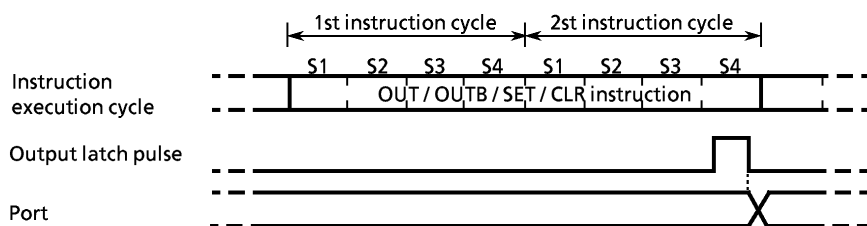

Figure 3-2. Output timing



3.1.2 I/O Ports

TMP47C660A/860A have 15 I/O ports (56 pins) each as follows:

- ① K0 ; 4-bit input
- ② P0, P1, P2, P3 ; 4-bit output
- ③ R4, R5 ; 4-bit input/output (shared with AD converter analog inputs)
- ④ R6 ; 4-bit input/output
- ⑤ R7 ; 4-bit input/output (shared with the low-frequency resonator connecting pins and the watchdog timer output)
- ⑥ R8 ; 4-bit input/output (shared with external interrupt request input and timer/counter input)
- ⑦ R9 ; 3-bit input/output (shared with serial port)
- ⑧ RA, RB, RC ; 4-bit input/output
- ⑨ KE ; 1-bit sense input (shared with hold request/release signal input)

Each output port contains a latch, which holds the output data.

The input ports have no latch; therefore, it is desired to hold data externally until it is read or read twice or more before processing it.

(1) Port K0 (K03 to K00)

Port K0 is a 4-bit input-only port. A pull-up or pull-down resistor can be contained by the mask option.



Figure 3-3. Port K0

(2) Ports P0 (P03 to P00) and P3 (P33 to P30)

Ports P0 and P3 are 4-bit output ports with latch. The latch is initialized to "0" during reset. When an input instruction is executed, the latch data are read as the port P3 but the port P0.

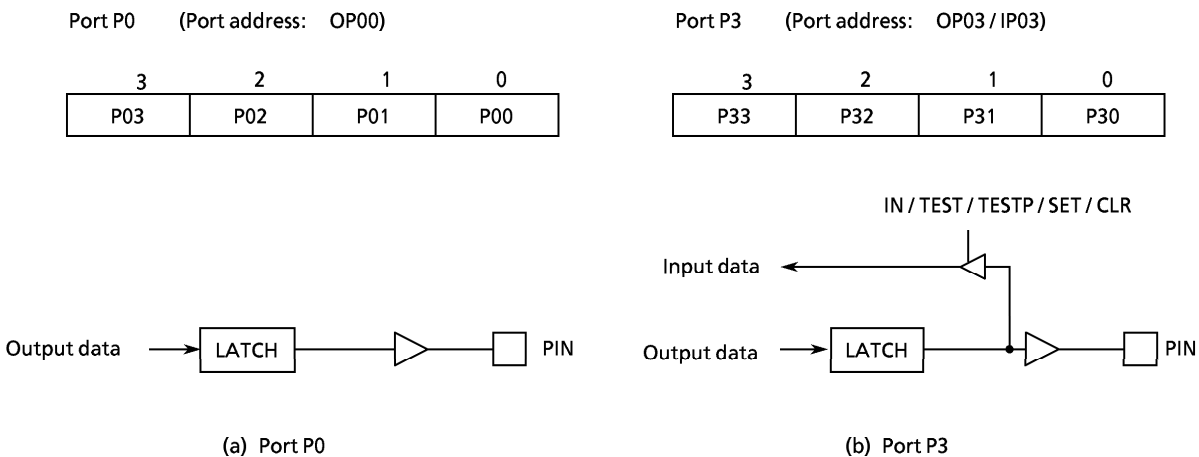

Figure 3-4. Ports P0, P3

(3) Ports P1 (P13 to P10) and P2 (P23 to P20)

Ports P1 and P2 are 4-bit high current output ports which can directly drive LEDs, with 4-bit latches. When an input instruction is executed, the latch data is read in these ports. The latch is initialized to "1" during reset. They can be accessed separately at port addresses OP01/IP01 and OP02/IP02. Additionally, 8-bit data can be set to these ports (the upper 4 bits to port P2, the lower 4 bits to port P1) by using the 5-bit to 8-bit data conversion instruction [OUTB @HL].

Example 1: To output immediate value "5" to port P1.

```
OUT      #5, %OP01 ; Port P1←5
```

Example 2: To read the latch data from port P2 to store it in the accumulator

```
IN       %IP02, A ; Acc←Port P2
```

Example 3: To read, from ROM, the 8-bit data corresponding to the 5 bits obtained by linking the content (1 bit) of the carry flag with the contents (4 bits) of at address 90<sub>H</sub> in RAM to output the 8-bit data to ports P2 and P1.

```
LD       HL, #90H ; HL←90H (Sets the RAM address)
OUTB    @HL      ; Port P2, P1←ROM data
```

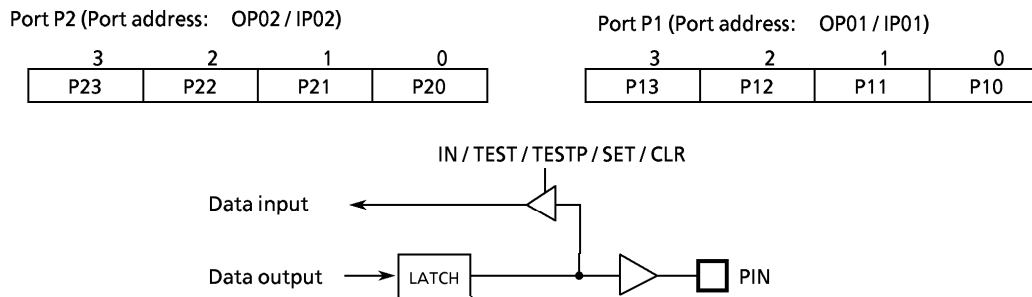

Figure 3-5. Ports P1, P2

(4) Ports R4 (R43 to R40), R5 (R53 to R50), R6 (R63 to R60), R7 (R73 to R70)

These ports are 4-bit I/O ports with a latch. When used as an input port, the latch must be set to "1". The latch is initialized to "1" during reset.

These 4 ports (16 pins) can be set, cleared, and tested for each bit as specified by L register indirect addressing bit manipulation instructions [SET @L], [CLR @L], and [TEST @L]. Table 3-2 lists the pins (I/O ports) that correspond to the L register contents.

Example: To clear R43 pin as specified by the L register indirect addressing bit manipulation instruction.

```
LD       L, #0011B ; Set R43 pin address to L register
CLR     @L          ; R43←0
```

Table 3-2. Relationship between L register contents and I/O port bits

L register				Pin
3	2	1	0	
0	0	0	0	R40
0	0	0	1	R41
0	0	1	0	R42
0	0	1	1	R43

L register				Pin
3	2	1	0	
0	1	0	0	R50
0	1	0	1	R51
0	1	1	0	R52
0	1	1	1	R53

L register				Pin
3	2	1	0	
1	0	0	0	R60
1	0	0	1	R61
1	0	1	0	R62
1	0	1	1	R63

L register				Pin
3	2	1	0	
1	1	0	0	R70
1	1	0	1	R71
1	1	1	0	R72
1	1	1	1	R73

a. Ports R4 (R43 to R40) and R5 (R53 to R50)

Ports R4 and R5 are 4-bit I/O ports with latch shared by the analog inputs for AD converter. When used as an input ports or analog inputs, the latch should be set to "1".

If other port is used as an output, be careful not to execute the output instruction for any port during AD conversion in order to keep accuracy of conversion.

The latch is initialized to "1" and analog input is selected R40 (AIN0) pin during reset.

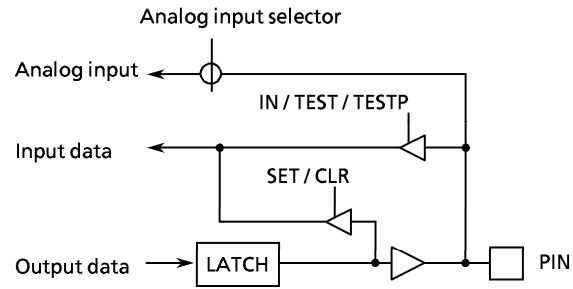
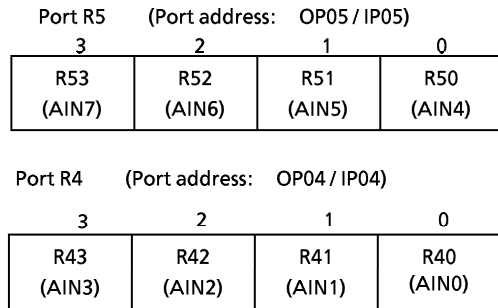

Figure 3-6. Ports R4, R5

b. Port R6 is 4-bit I/O port with a latch. When used as an input, the latch must be set to "1". The latch is initialized to "1" during reset.

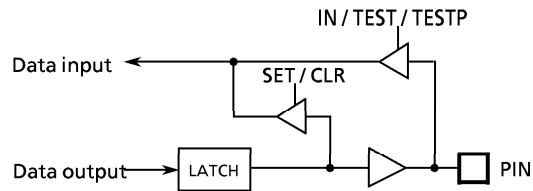
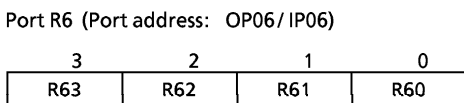

Figure 3-7. Port R6



- c. Port R7 is shared by the low-frequency resonator connection pins (XTIN, XTOUT) and the watchdog timer output pin ( $\overline{WTO}$ ). For the dual-clock mode operation, the low-frequency resonator (32.768kHz) is connected to R72 (XTIN) and R73 (XTOUT) pins. For the single-clock mode operation, R72 and R73 pins are used for the ordinary I/O ports. When the watchdog timer is used, R71 ( $\overline{WTO}$ ) becomes the watchdog timer output pin. The watchdog timer output is the logical AND output with the port R71 output latch. To use the R71 pin for an ordinary I/O port, the watchdog timer must be disabled (with the watchdog timer output set to "1").

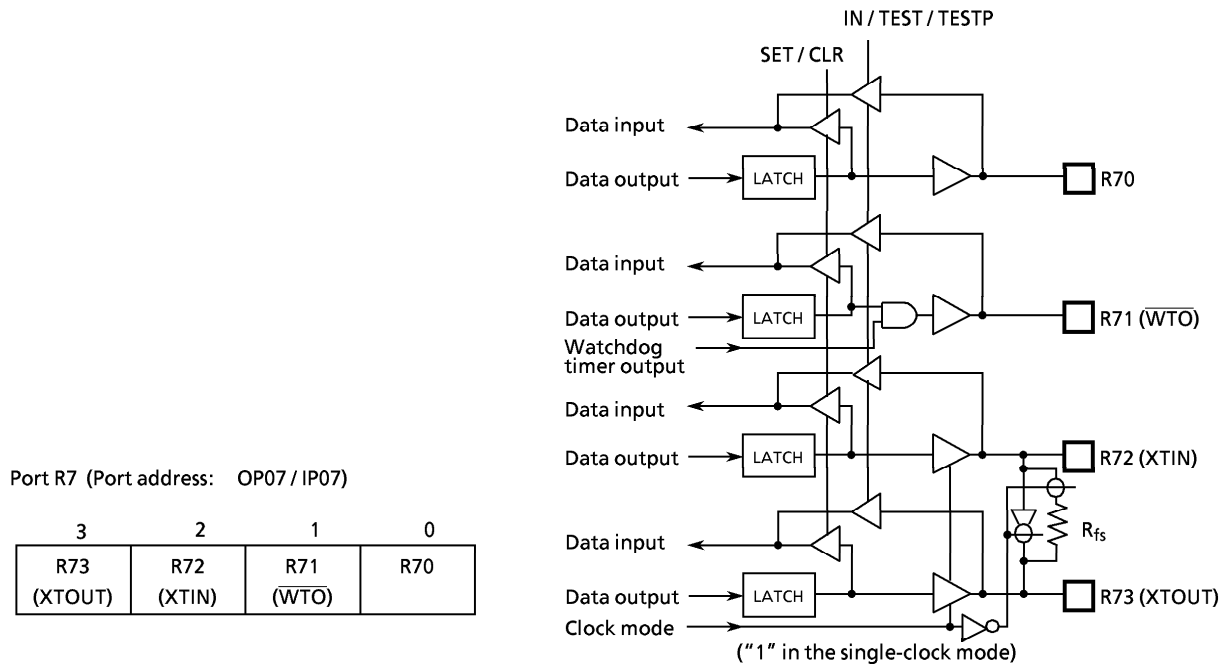

Figure 3-8. Port R7

## (5) Port R8 (R83 to R80)

Port R8 is a 4-bit I/O port with a latch. When used as an input port, the latch must be set to "1". The latch is initialized to "1" during reset. Port R8 is shared by the external interrupt request input pin and the timer/counter input pin. To use this port for one of these functional pins, the latch should be set to "1". To use it for an ordinary I/O port, the acceptance of external interrupt must be disabled or the event counter/pulse width measurement modes of the timer/counter must be disabled.

**Note:** When R82 ( $\overline{INT1}$ ) pin is used for an I/O port, external interrupt 1 occurs upon detection of the falling edge of pin input, and if the interrupt enable master flip-flop is enabled, the interrupt request is always accepted, so that a dummy interrupt processing must be performed (only the interrupt return instruction [RETI] is executed).  
With R80 ( $\overline{INT2}$ ) pin, external interrupt 2 occurs like R82 but bit 0 of the interrupt enable register is only kept at "0", not accepting the interrupt request.

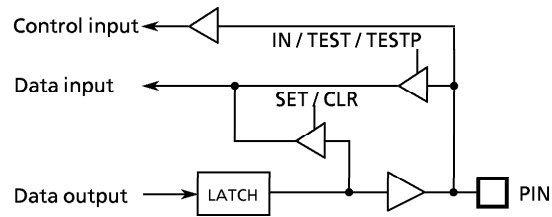
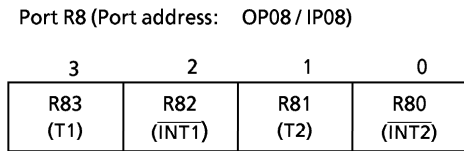

Figure 3-9. Port R8

(6) Port R9 (R92 to R90)

Port R9 is a 3-bit I/O port with latch. When used as an input, the latch must be set to "1". The latch is initialized to "1" during reset. Port R9 is shared with the serial port.

To use port R9 for the serial port, the latch should be set to "1". To use port R9 for an ordinary I/O port, the serial port must be disabled. Although R93 pin does not exist actually, execution of the set or clear instruction for R93 ([SET %OP09,3] or [CLR %OP09,3]) affects the operation of the internal CPU. Therefore, these instructions should not be execution on R93. However, other instructions may be used, in which an uncertain value is read upon execution of an input instruction.

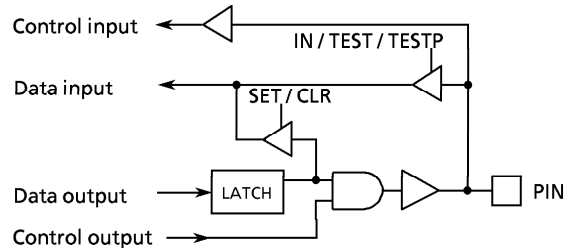
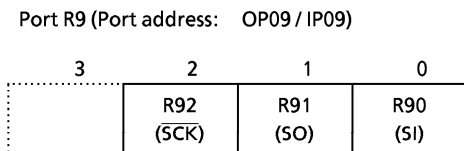

Figure 3-10. Port R9

(7) Port KE ( $\overline{KE0}$ ), Port K10 ( $\overline{K103}$ )

Port KE or Port K10 is a 1-bit sense input port shared by the hold request/release signal input pin (HOLD). This input port is assigned to the least significant bit of port address IP0E or the most significant bit of port address IP10 and both input data is processed as the data with inverted polarity. For example, if an input instruction is executed with the pin on the high level, "0" is read. Note that  $\overline{KE0}$  port cannot be used in the dual-clock mode

Example: To wait until  $\overline{KE0}$  pin goes low. (in single clockmode.)

```

SWAIT:   TEST   %IP0E, 0 ; Waits if  $\overline{KE0}$  pin = "L".
        B       SWAIT
    
```

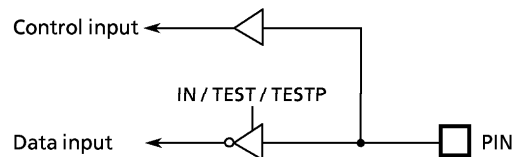
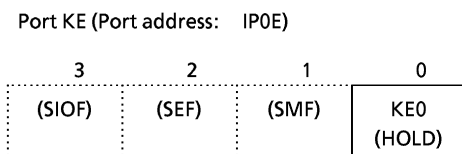

Figure 3-11. Port KE

- (8) Ports RA (RA3 to RA0), RB (RB3 to RB0), RC (RC3 to RC0)  
 These ports are 4-bit I/O ports with latch. The latch is initialized to "1" during reset.  
 When used as input port, the latch should be set to "1".

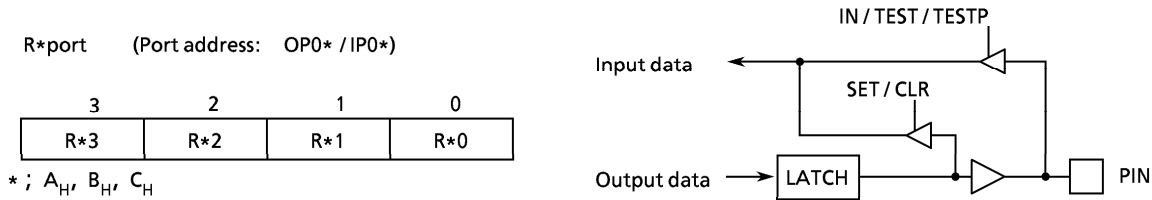

Figure 3-12. Ports RA, RB, RC

### 3.2 Interval Timer

The interval timer can be used to generate an interrupt with a fixed frequency. An interval timer interrupt is controlled by the command register (OP19). And the command register (OP19) is initialized to "0" during reset. An interval timer interrupt is generated at the first rising edge of the binary counter output after the command has been set. The interval timer is not cleared by command, so that the first interrupt may occur earlier than the preset interrupt period.

Example: To set the interval timer interrupt frequency to  $fc/2^{15}$ [Hz] (Single clock mode)

```
LD    A,#0110B ; OP19 ← 0110B
OUT   A,%OP19
```

Interval timer interrupt control command register  
 (Port address: OP19)



TMRE	Interrupt Enable / Disable	TMRF	Interrupt frequency
00:	Stopped	00:	$fc/2^{11}$ or $fs/2^4$ [Hz]
01:	Enable	01:	$fc/2^{13}$ or $fs/2^6$
1*:	Reserved	10:	$fc/2^{15}$ or $fs/2^8$
		11:	$fc/2^{17}$ or $fs/2^{10}$

Note 1: \* ; Don't care  
 Note 2:  $fc$  ; High-frequency clock [Hz],  
 $fs$  ; Low-frequency clock [Hz]

(a) Command register

TMRF	Normal - 1	Normal - 2		SLOW	$fc = 4.194304$ MHz, $fs = 32.768$ kHz
		SLCK = 0 ( $fc/2^7$ )	SLCK = 1 ( $fs$ )		
00	$fc/2^{11}$ [Hz]	$fs/2^4$ [Hz]	Reserved	2048 [Hz]	
01	$fc/2^{13}$	$fs/2^6$	"	512	
10	$fc/2^{15}$	$fs/2^8$	"	128	
11	$fc/2^{17}$	$fs/2^{10}$	$fs/2^{10}$	32	

(b) Example of interrupt frequency

Figure 3-13. Interval timer interrupt command register

### 3.3 Timer/Counters (TC1, TC2)

The TMP47C660A/860A contains two 12-bit timer/counters. RAM addresses are assigned to the count register in unit of 4 bits, permitting the initial value setting and counter reading through the RAM manipulation instruction.

When the timer/counter is not used, the mode selection may be set to "stopped" to use the RAM at the address corresponding to the timer/counter for storing the ordinary use-processed data.

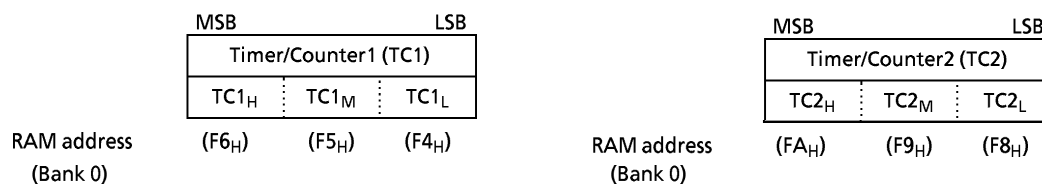

Figure3-14. The count registers of the timer/counters (TC1, TC2)

#### 3.3.1 Functions of timer/counters

The timer/counters provide the following functions:

- ① Event counter
- ② Programmable timer
- ③ Pulse width measurement

### 3.3.2 Control of timer/counters

The timer/counters are controlled by the command registers. The command register is accessed as port address OP1C for timer/counter 1, and port address OP1D for timer/counter 2. These registers are initialized to "0" during reset.

Timer/counter 1 control command register  
(Port address: OP1C) (Initial value: 0000)

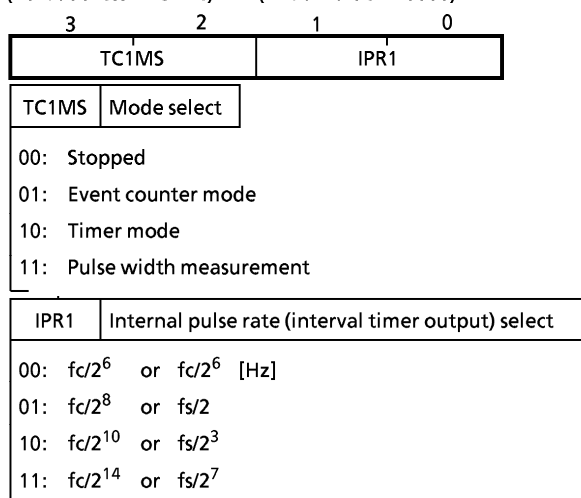

Timer/counter 2 control command register  
(Port address: OP1D) (Initial value: 0000)

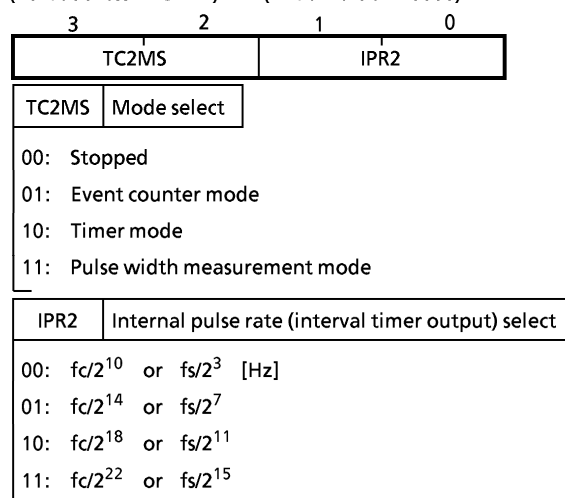

Note:  $fc$ ; High-frequency clock [Hz]  
 $fs$ ; Low-frequency clock [Hz]

(a) Command Register

Normal - 1	Normal - 2		SLOW	$(fc = 4.194304 \text{ MHz}, fs = 32.768 \text{ kHz})$
	SLCK = 0 ( $fc/2^7$ )	SLCK = 1 ( $fs$ )		
$fc/2^6$ [Hz]	$fc/2^6$ [Hz]	Reserved	$2^{18}/fc$	(0.0625)
$fc/2^8$	$fs/2$	"	$2^{20}/fc$ or $2^{13}/fs$	(0.25)
$fc/2^{10}$	$fs/2^3$	"	$2^{22}/fc$ or $2^{15}/fs$	(1)
$fc/2^{14}$	$fs/2^7$	$fs/2^7$	$2^{26}/fc$ or $2^{19}/fs$	(16)
$fc/2^{18}$	$fs/2^{11}$	$fs/2^{11}$	$2^{30}/fc$ or $2^{23}/fs$	(256)
$fc/2^{22}$	$fs/2^{15}$	$fs/2^{15}$	$2^{34}/fc$ or $2^{27}/fs$	(4096)

(b) Internal Pulse Rate Selection

Figure 3-15. Timer/Counter control

The timer/counter increments at the rising edge of each count pulse. Counting starts with the first rising edge of the count pulse generated after the command has been set. Count operation is performed in 1 instruction cycle after the current instruction execution, during which the execution of a next instruction and the acceptance of an interrupt are delayed. If counting is requested by both TC1 and TC2 simultaneously, the request by TC1 is preferred. The request from TC2 is accepted in the next instruction cycle. Therefore, during a count operation, the apparent instruction execution speed drops as counting occurs more frequently. The timer/counter causes an interrupt upon occurrence of an overflow (a transition of the count value from FFF<sub>H</sub> to 000<sub>H</sub>). If the timer/counter is during the interrupt enabled state and the overflow interrupt is accepted immediately after its occurrence, the interrupt is processed in the sequence shown in Figure 3-16. Note that counting continues if there is a count request after overflow occurrence.

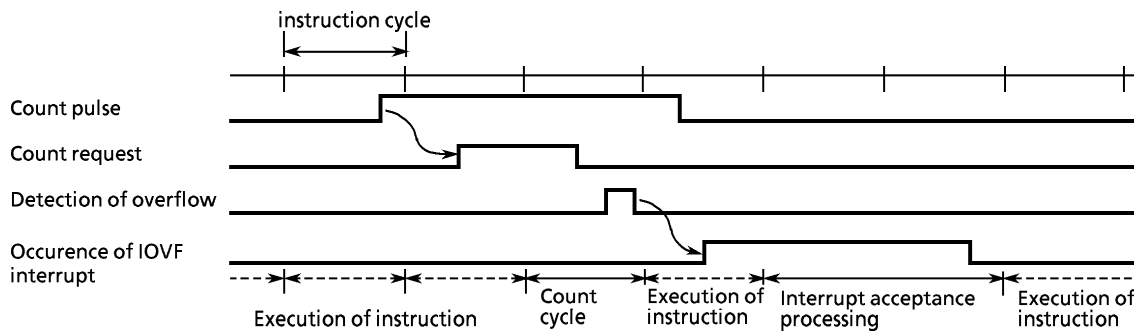

Figure 3-16. Timer/Counter overflow interrupt timing

(1) Event counter mode

In the event counter mode, the timer/counter increments at each rising edge of the external pin (T1, T2) input. T1, T2 pins are shared by R83, R81 pins. Output latch of R83, R81, are set to "1" when used as timer/counter input. Also output latch is initialized "1" during reset. The maximum applied frequency of the external pin input is  $f_c/32$  for the 1-channel operation; for the 2-channel operation, the frequency is  $f_c/32$  for TC1 and  $f_c/40$  for TC2. The apparent instruction execution speed drops most to  $(9/11) \times 100 = 82\%$  when TC1 and TC2 are operated at the maximum applied frequency because the count operation is inserted once every 4 instruction cycles for TC1 and every 5 instruction cycles for TC2. For example, the instruction execution speed of  $2\mu s$  drops to  $3.64\mu s$ .

Example: To operate TC2 in the event counter mode.

```
LD    A, #0100B      ; OP1D ← 01**B
OUT   A, %OP1D
```

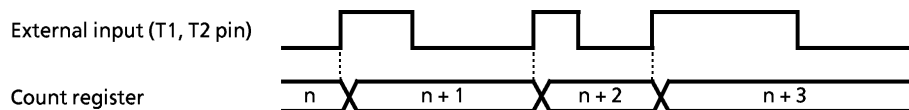

Figure 3-17. Event counter mode timing chart

(2) Timer mode

In the timer mode, the timer/counter increments at the rising edge of the internal pulse generated from the interval timer. One of 4 internal pulse rates can be selected by the command register. The selected rate can be initially set to the timer/counter to generate an overflow interrupt in order to create a desired time interval.

When an internal pulse rate of  $f_c/2^{10}$  is used, a count operation is inserted once every 128 instruction cycles, so that the apparent instruction execution speed drops by  $(1/127) \times 100 =$

0.8%. For example, the instruction execution speed of 2  $\mu\text{s}$  drops to 2.016  $\mu\text{s}$ . In the timer mode, R83 (T1) and R81 (T2) pins provide the ordinary I/O ports.

Example: To generate an overflow interrupt (at  $f_c = 4 \text{ MHz}$ ) by TC1 after 100 ms.

```
LD    HL, #0F4H      ; TC1 ← E79H (Setting of count register)
ST    #9, @HL+
ST    #7, @HL+
ST    #0EH, @HL+
LD    A, #1010B     ; OP1C ← 1010B (Timer mode rate  $f_c/2^{10}$ )
OUT   A, %OP1C
LD    A, #0100B     ; EIR ← 0100B (Enables interrupt)
XCH   A, EIR
EICLR IL, 110111B  ; EIF ← 1, IL3 ← 0
```

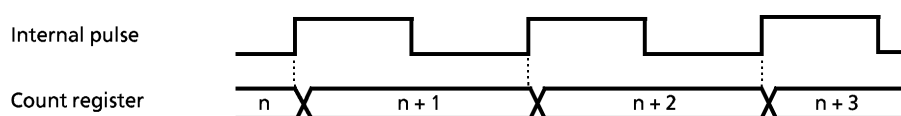

Figure 3-18. Timer mode timing chart

- \* The drop of the apparent instruction execution speed can be calculated by the following way

$$1 \div \left\{ \frac{(\text{basical clock freq.}) / 8}{(\text{internal pulse rate})} - 1 \right\} \times 100 [\%]$$

- \* Calculating the initial value of the count register

$$2^{12} - (\text{interrupt setting time}) \times (\text{internal pulse rate})$$

For example, to generate an overflow interrupt after 100 ms at  $f_c = 4 \text{ MHz}$  with the internal pulse rate of  $f_c/2^{10}$ , set the following value to the count register as the initial value:

$$2^{12} - (100 \times 10^{-3}) \times (4 \times 10^6 / 2^{10}) = 3705 \text{ (E79<sub>H</sub>)}$$

### (3) Pulse width measurement mode

In the pulse width measurement mode, the timer/counter increments with the pulse obtained by sampling the external pins (T1,T2) by the internal pulse. As shown in Figure 3-19, the timer/counter increments only while the external pin input is high. The maximum applied frequency to the external pin input must be one that is enough for analyzing the count value by program. Normally, a frequency sufficient slower than the internal pulse ratesetting is applied to the external pin.

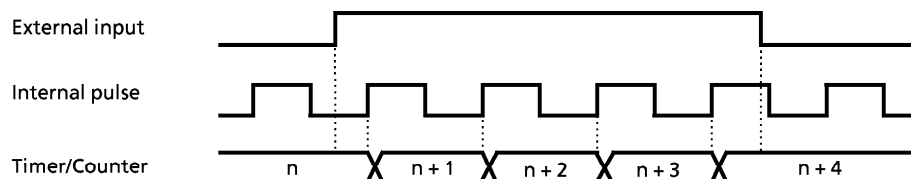

Figure 3-19. Pulse width measurement mode timing chart

### 3.4 Watchdog Timer (WDT)

The watchdog timer capability is provided to quickly detect the CPU malfunction such as endless looping caused by noises or the like, and restore the CPU to the normal state.

The watchdog timer output appears on R71 ( $\overline{WTO}$ ) pin as the malfunction detect signal. To use the WDT, the output latch of R71 must be set to "1" (during reset, it is set to "1"). Note that, the WDT is disabled during reset. Connecting the  $\overline{WTO}$  pin and the  $\overline{RESET}$  pin resets malfunction.

#### 3.4.1 Configuration of watchdog timer

The WDT consists of 10 binary counters, a flip-flop, and a controller. Source input clock of binary counters is  $f_c/27$ [Hz] or  $f_s$ [Hz]. Figure 3-21 (b) shows watchdog timing detection time and operating mode (detection time of watchdog timer).

The flip-flop is set to "1" during reset, and cleared to "0" on the rising edge of the binary counter output.

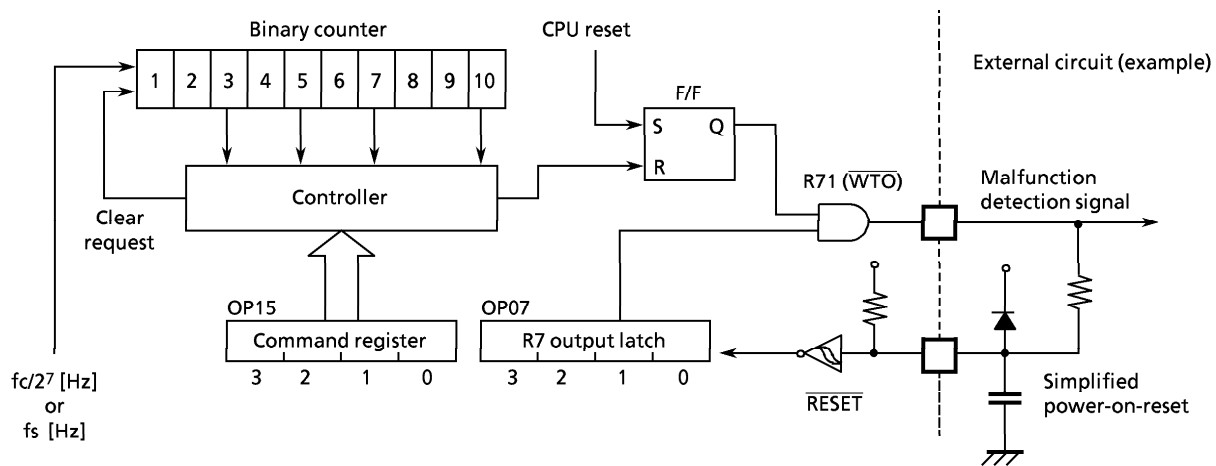

Figure 3-20. Configuration of watchdog timer

#### 3.4.2 Control of watchdog timer

The WDT is controlled by the command register (OP15). The command register is initialized to "1000<sub>B</sub>" during reset.

To detect the CPU malfunction by the WDT:

- ① Set the WDT detection time, and clear the binary counters.
- ② Enable the WDT.
- ③ Clear the binary counters within WDT detection time that was set in ①. If a CPU malfunction occurs, preventing the binary counters from being cleared, the flip-flop is cleared to "0" on the rising edge of the binary counter output, making the malfunction detection signal active. If the output latch of R71 is "1" at this time, the  $\overline{WTO}$  output goes low.



Example: To enable the with detection time of  $63 \times 2^{15}/fc$  [s]

```

LD      A, #0010B      ; OP15 ← 0010B (Set WDT detection time, clear
OUT     A, %OP15      ;                      binary counters)
LD      A, #0110B      ; OP15 ← 0110B (Enable WDT)
OUT     A, %OP15
:
:
:
LD      A, #0110B      ; OP15 ← 0110B (Clear binary counters)
OUT     A, %OP15
:
:

```

Within WDT detection timer

**Note:** It is necessary to clear the binary counter prior to enabling watchdog timer. Further, the Watchdog Timer should be disable by program during warm-up time from SLOW operating mode to Normal-2 operating mode.

Watchdog timer control command register (Port address: OP15)

3	2	1	0
RWT	EWT	TWT	

(Initial value: 1000)

**Clears Binary counter**  
 0: Binary counter cleared  
 (after clear, it is automatically set to "1")

**Watchdog timer enable/disable**  
 0: Disable  
 1: Enable

**Set Watchdog timer detection time**

Example: At  $fc = 4.19$  MHz

00:	$3 \times 2^{15}/fc$ [s]	.....	23 [ms]
01:	$15 \times 2^{15}/fc$	.....	117
10:	$63 \times 2^{15}/fc$	.....	493
11:	$511 \times 2^{15}/fc$	.....	3996

**Note:**  $fc$  ; High-frequency clock [Hz]  
 $fs$  ; Low-frequency clock [Hz]

(a) Command Register

TWT	Normal 1	Normal 2		SLOW	$fc = 4.194304$ MHz, $fs = 32.768$ kHz
		SLCK = 0 ( $fc/2^7$ )	SLCK = 1 ( $fs$ )		
00	$3 \times 2^{15}/fc$ [s]		$3 \times 2^8/fs$ [s]		23.4 [ms]
01	$15 \times 2^{15}/fc$		$15 \times 2^8/fs$		117
10	$63 \times 2^{15}/fc$		$63 \times 2^8/fs$		492
11	$511 \times 2^{15}/fc$		$511 \times 2^8/fs$		3992

(b) Watchdog Timing detection time

Figure3-21. Watchdog timer control command register

### 3.5 Remote Control Pulse Detector

The remote control pulse detector counts the edge-to-edge time of the input pulse and generates an interrupt request each time that the switching edge of an input pulse is detected. Remote control signal waveform which has been rectified by the receiver is inputted to the R80 ( $\overline{\text{INT2}}$ ) pin.

#### 3.5.1 Circuit configuration

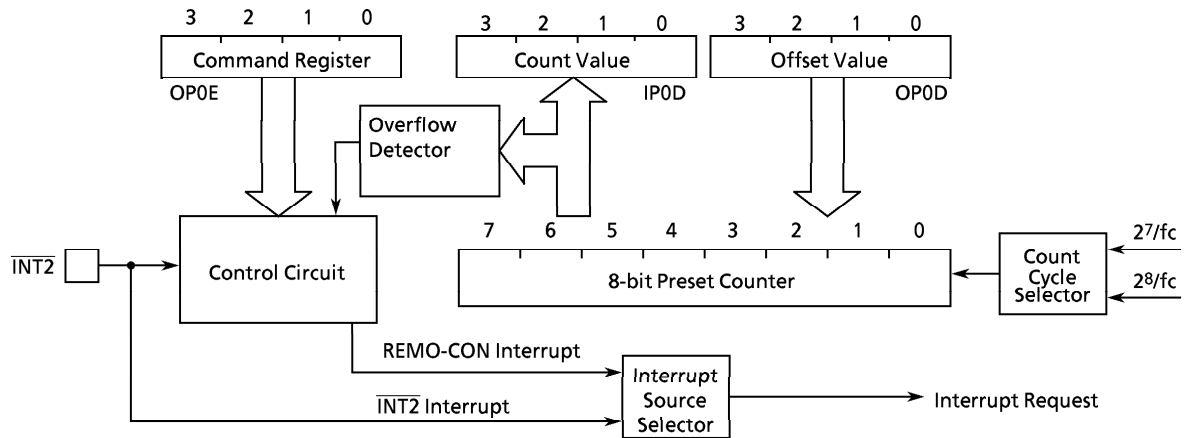
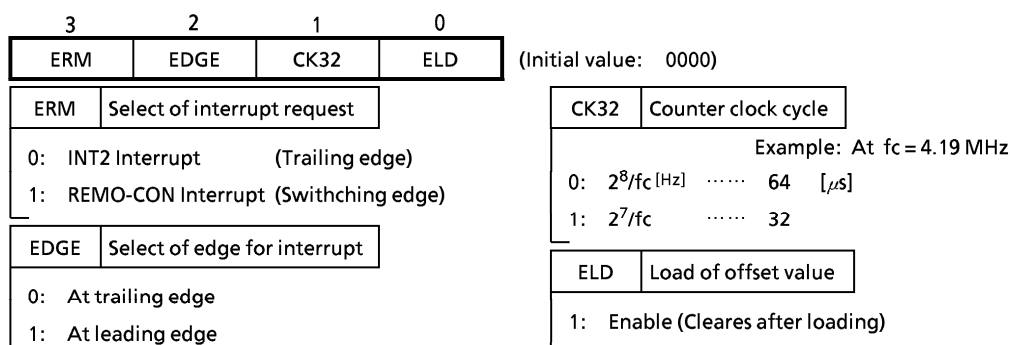

Figure 3-22. Remote control pulse detector

### 3.5.2 Control of remote control pulse detector

The remote control pulse detector is controlled by the command register (OP0E) Also, external interrupt 2 is used to interrupt source. At reset, INT2 is selected, so a remote control discrimination interrupt is selected by command. Interrupt enable master F/F (EIF) and interrupt enable register (EIR) are used to enable/disable remote control discrimination interrupt. The interrupt priority is the same as for external interrupt 2.

REMO-CON pulse detector command register  
(Port address: OP0E)



Note: EDGE, CK32, ELD is available when ERM = 1

Figure 3-23. Command register

#### (1) 8-bit preset counter

This a binary counter which counts the time from edge to next edge. A value of offset value register (OP0D) are loaded to the lower 4 bits and the value of the upper 4 bits are stored to the count value register (IP0D).

Offset value is loaded in the following cases:

- ① When ELD (bit 0 of the OP0E) is set to "1".
- ② When there is an overflow of the lower 4 bits.
- ③ When interrupt request occurs.

Count value is stored in the following cases:

- ① When the upper 4 bits are all "1111<sub>B</sub>".
- ② When interrupt request occurs.

## (2) Reference time and detection time

The reference time must be created before measuring the pulse width of the remote control signal waveform. Reference time is set the value shown in Table 3-5. by the count cycle of the preset counter selected with the OP0E and the offset value set to the OP0D. Therefore, the product of the reference time and the count value read from the IP0D becomes the detection time. However, a worst error of the detection time is equivalent to reference time.

Table 3-3. Set value of reference time

Count clock cycle	Offset value (HEX)	Reference time (n = 0~15)
$2^7/fc$ [s]	0 to F	$(2^{11} - n \times 2^7)/fc$ [s]
$2^8/fc$	0 to F	$(2^{12} - n \times 2^8)/fc$

## (3) Remote control pulse detector operation

First, set the offset value for creating the reference time to the OP0D. The offset value is loaded to the lower 4 bits of preset counter by setting ELD to "1". ERM can also be set to "1" at the same time. Setting ERM starts counting. ELD is cleared after loading but it is automatically loaded during the count by an overflow of the lower 4 bits.

After storing the count value in the IP0D by detecting the switching edge (leading/trailing) of the input pulse, the preset counter again loads the offset value to the lower 4 bits, clears to "0" the upper 4 bits and restarts counting.

An interrupt request is generated at this time. Therefore, read the count value in the interrupt service routine. The next interrupt is disabled until the stored count value is read. Switching edges can select in one by one using EDGE.

If the upper 4 bits of counter becomes "1111<sub>B</sub>" before the next edge is accepted, it is judged to be an overflow and the interrupt is generated.

In this case, IP0D is set to "FH" and it can be identified to be the overflow interruption. The input pulse width of both "H" and "L" levels must be more than  $192/fc$  [s]. If any shorter pulse than  $192/fc$  [s] may be expected, put the dummy instruction [IN %IP0D, A] reading out from count value register in the main routine.

Even if ERM is "0", when an INT2 interrupt source is enabled (determined by EIF, EIR), an interrupt request is generated by a falling edge of input pulse.

Figure 3-24. shows the operation timing the remote control pulse detector.

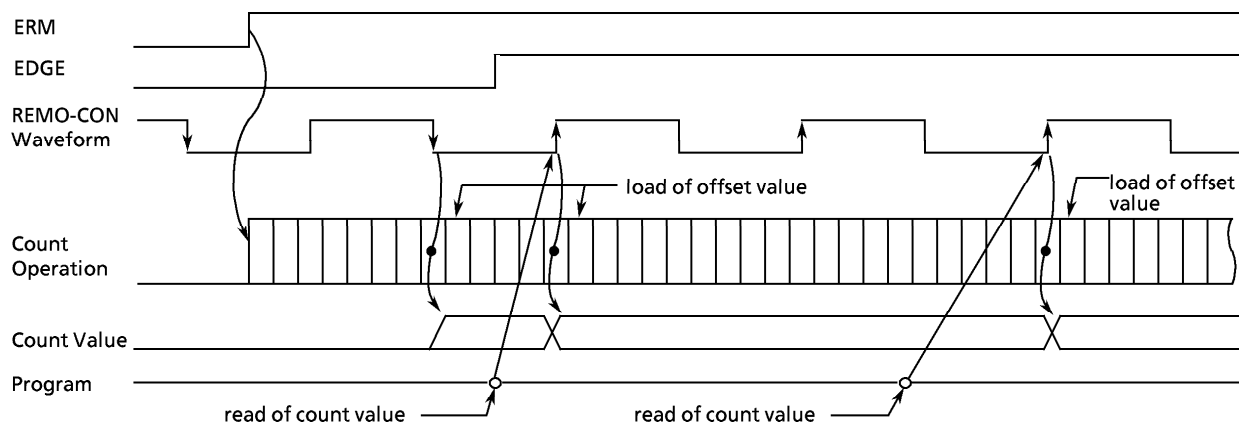

Figure 3-24. Timing chart

Example: To store a count value to RAM [10<sub>H</sub>] that pulse width of input pulse is measured.



#### Main Routine

```

OUT  #5, %OP0D ; Offset value register set to "5".
OUT  #0FH, %OP0E ; Interrupt enable with setting count cycle to 32 μs,
                  leading edge detection mode.

CLR  0, 0 ; Clear to RAM [00H] 0 as interrupt status flag.
LD   A, #0001B ; Interrupt enable
XCH  A, EIR
EICLR IL, #111110B
:

```

#### INT2 service routine

```

TEST 0, 0 ; Skip, if interrupt status flag is "0".
B     ST0
LD   HL, #10H ; HL ← 10H
IN   %IP0D, @HL ; RAM [10H] ← Count value
CLR  0, 0 ; Clearing interrupt status flag.
OUT  #0EH, %OP0E ; Set to leading edge detection mode.
B     SEND
ST0: SET 0, 0 ; Setting interrupt status flag.
      OUT #0AH, %OP0E ; Set to trailing edge detection mode.
      IN  %IP0D, A ; Dummy
SEND: :

```

\* Calculation of pulse width with the above program when the count value stored to the RAM [10<sub>H</sub>] is "9".

When the clock frequency is 32 μs (fc = 4.19 MHz) and the offset value is "5", the reference time will be as follows:

$$(2^{11} - 5 \times 2^7) / f_c = 336 [\mu s]$$

Thus, the detection time (pulse width) will be  $336 \times 9 = 3.02$  [ms]  
(including an error of 336 μs max.)

### 3.6 AD Converter

TMP47C660A/860A have a 8-bit successive approximate type AD converter and is capable of processing 8 analog inputs.

#### 3.6.1 Circuit configuration

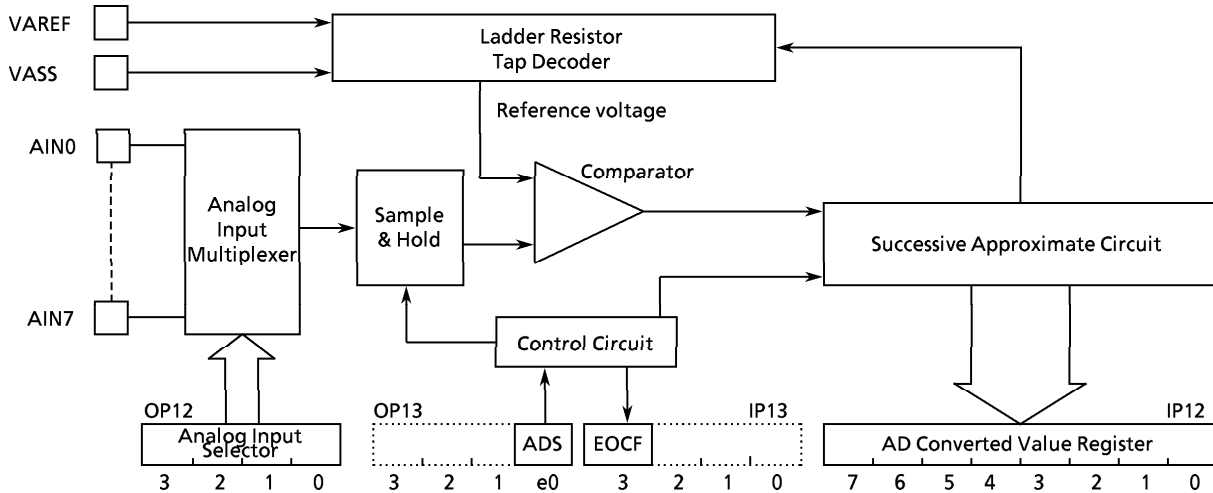

Figure 3-25. Block diagram of AD converter

#### 3.6.2 Control of AD converter

The operation of AD converter is controlled by a command. The command register is accessed as port addresses OP12 and OP13.

- (1) Analog input selector (OP12)  
Analog inputs (AIN0 through AIN7) are selected by this register.

Analog input select command register  
(Port address: OP12)

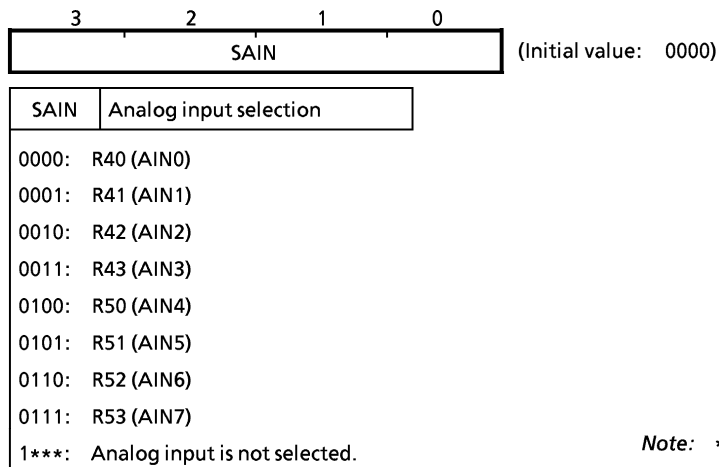

Figure 3-26. Analog input selector

(2) Start of AD conversion (OP13)

AD conversion is started when ADS is set to "1". After the conversion is started, ADS is cleared by hardware. If the restart is requested during the conversion, the conversion is started again at the time.

A also, analog input voltage is hold by the sample hole circuit.

AD conversion start command register  
(Port address: OP13)

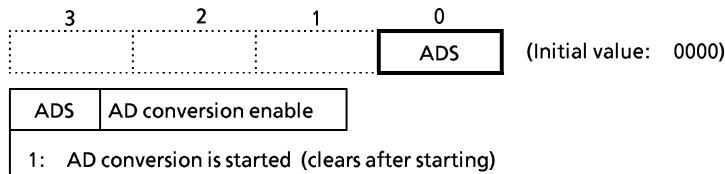

Figure 3-27. AD conversion start register

(3) AD converter status register AD converter end frag (IPB)

End of conversion flag (EOCF) is a single bit flag showing the end of conversion and is set to "1" when conversion ended. When both upper 4 bits and lower 4 bits of a converted value are read or AD conversion is started, EOCF is cleared to "0".

AD converter status register  
(Port address: IP13)

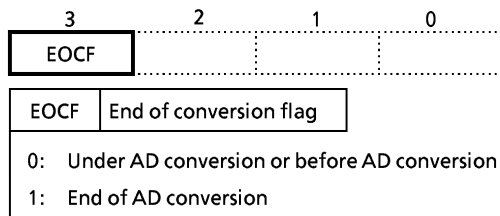

Figure 3-28. AD converter status register

(4) AD converted value register (IP12)

An AD converted value is read by accessing port address IP12. An AD converted value is read by splitting into upper 4 bits and lower 4 bits by a value of LR<sub>0</sub> (LSB of the L registers).

AD converted value register  
(Port address: IP12)

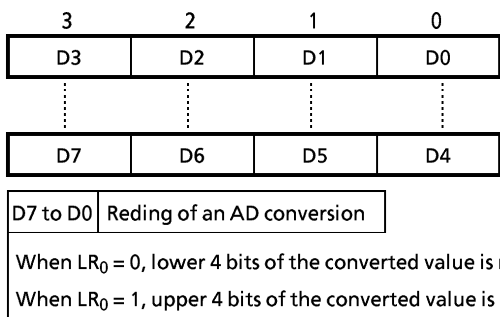

Figure 3-29. AD converted value register

### 3.6.3 How to use AD converter

Apply positive of analog reference voltage to the VAREF pin and negative to the VASS pin. The AD conversion is carried out by splitting reference voltage between VAREF and VASS to bit corresponding voltage by a ladder resistor and making a judgement by comparing it with analog input voltage.

#### (1) Start of AD conversion

Prior to conversion, select one of the analog input AIN0 through AIN7 by the analog input selector. Place output of the analog input, which is to be AD converted, in the high impedance state by setting "1". If other port is used as an output port, be careful not to execute the output instruction for any port during conversion in order to keep accuracy of conversion.

AD conversion is started by setting ADS (bit1 of the AD conversion start register). When conversion ends after 24 instruction cycles, EOCF showing the end of conversion is set to "1".

Also, analog input voltage is sampled during the following 2 instruction cycles after setting ADS.

*Note: The sample and hold circuit has capacitor (CA = 12 pF typ.) with resistor (RA = 5 kΩ typ.). See I/O circuitry table. This capacitor should be charged or discharged within 2 instruction cycles.*

#### (2) Reading of an AD converted value

After the end of conversion, read an AD converted value is read by splitting into lower 4 bits and upper 4 bits by the AD converted value register (IP12). Lower 4 bits of the AD converted value can be read when LR<sub>0</sub> = 0 and upper 4 bits when LR<sub>0</sub> = 1. Usually an AD converted value is stored in RAM by an instruction [IN %p, @HL]. Further, if an AD converted value is read during conversion, it becomes an indefinite value.

#### (3) AD conversion with HOLD operation

When the HOLD operation is started during the conversion, the conversion is terminated and an AD converted value becomes indefinite. Therefore, EOCF is kept clear to "0" after release from the HOLD operation. However, if the HOLD operation is started after the end of conversion (after EOCF has been set), AD converted value and status of EOCF are held.

Example: Selecting analog input (AIN4), starting AD conversion, monitoring EOCF, and storing lower 4 bits and upper 4 bits of a converted value to RAM [10<sub>H</sub>] and RAM [11<sub>H</sub>] respectively.

```

LD      A, #4H          ; Selecting analog input (AIN4)
OUT     A, %OP12
LD      A, #1H          ; Start of AD conversion
OUT     A, %OP13
SLOOP:  IN      %IP13, A ; To wait until EOCF goes to "1"
        TEST   A, 3
        B     SLOOP
LD      HL, #10H        ; HL ← 10H
IN      %IP12, @HL     ; RAM [10H] ← Lower 4 bits
INC     L               ; Increment of L registers
IN      %IP12, @HL     ; RAM [11H] ← Upper 4 bits

```



### 3.7 Serial Interface (SIO)

The TMP47C660A/860A have a serial interface with an 8-bit buffer. The serial interface is connected to the external device via 3 pins (the serial port): R92 ( $\overline{SCK}$ ), R91 (SO), and R90 (SI). The serial port is shared by port R9. For the serial port, the output latch of port R9 must be set to "1". In the transmit mode, R90 pin provides the I/O port; in the receive mode, R91 pin provides the I/O port.

#### 3.7.1 Configuration of serial interface

Figure 3-30 shows configuration of serial interface.

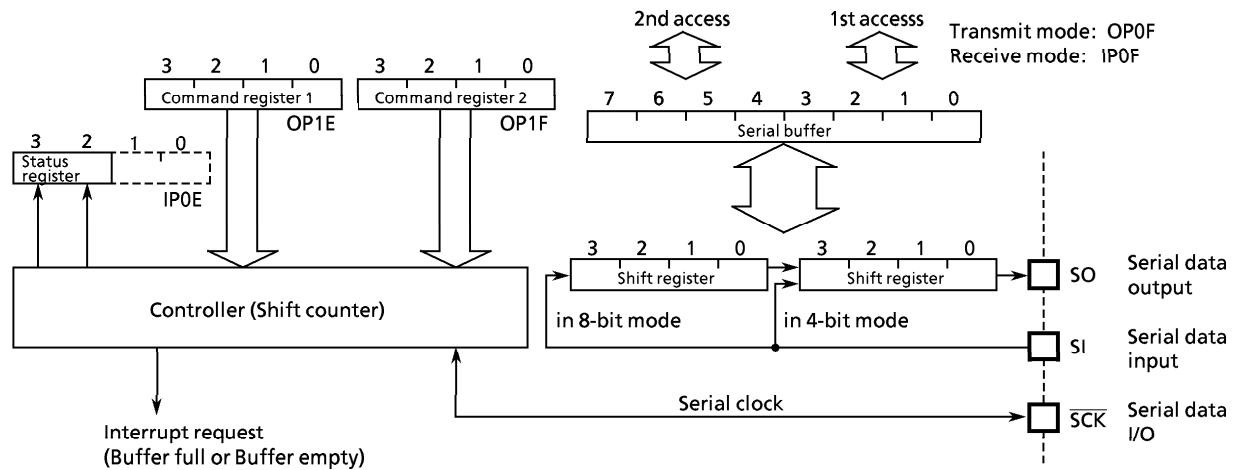
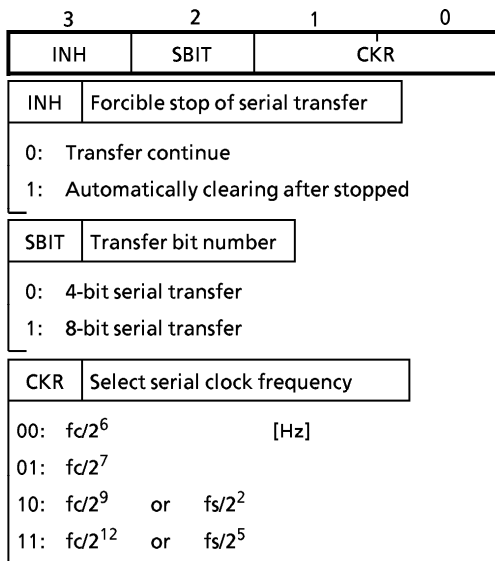

Figure 3-30. Configuration of serial interface

#### 3.7.2 Control of serial interface

The serial interface is controlled by command registers1, 2 (OP1E, OP1F). The operating states of the serial interface can be monitored by the status register (IPOE).

Serial interface control command register 1  
(Port address: OP1E) (Initial value: 0001)



**Note 1:**  $f_c$ ; High-frequency clock [Hz]  
 $f_s$ ; Low-frequency clock [Hz]  
**Note 2:** When setting the transfer mode, ESIO must be "0"  
**Note 3:** Transmit/Receive mode: Don't care.  
Transmit mode: LM = 1.

Serial interface control command register 2  
(Port address: OP1F) (Initial value: 0000)

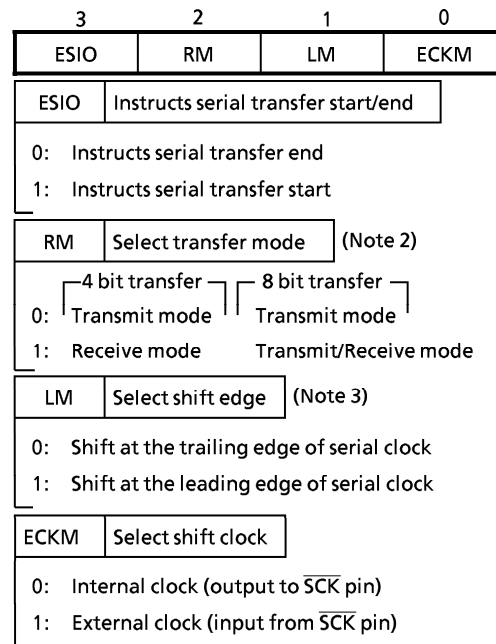

CKR	Normal-1	Normal-2		SLOW	$f_c = 4.194304$ MHz, $f_s = 32.768$ kHz
		SLCK = 0 ( $f_c/2^7$ )	SLCK = 1 ( $f_s$ )		
00	$f_c/2^6$ [Hz]	$f_c/2^6$ [Hz]	Reserved	"	65536 [Hz]
01	$f_c/2^7$	$f_c/2^7$	"	"	32768
10	$f_c/2^9$	$f_s/2^2$	"	"	8192
11	$f_c/2^{12}$	$f_s/2^5$	$f_s/2^5$	"	1024

Figure 3-31. Serial interface control command register

Serial interface status register  
(Port address: IPOE)

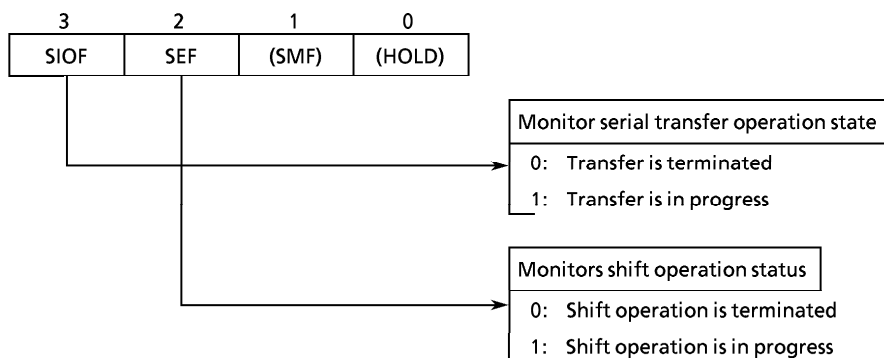

Figure 3-32. Serial interface status register

### 3.7.3 Serial clock

For the serial clock, one of the following can be selected according to the contents of the command registers:

- (1) Clock source selection
  - a. Internal clock

The serial clock frequency is selected by command register 1.  
The serial clock is output on the  $\overline{SCK}$  pin. Note that the start of transfer, the  $\overline{SCK}$  pin output goes high. This device provides the wait function in which the shift is not occurred until these processings are completed.  
The highest transfer rate based on the internal clock is 93750 bits/second (at  $f_c = 6$  MHz).
  - b. External clock

The signal obtained by the clock supplied to the  $\overline{SCK}$  pin from the outside is used for the serial clock. In this case, the output latch of R92 ( $\overline{SCK}$ ) must be set to "1" beforehand. For the shift operation to be performed correctly, each of the serial clock high and low levels needs 2 instruction cycles or more to be completed.
- (2) Shift edge selection
  - a. Leading edge

Date is shifted at the leading edge (the falling edge of  $\overline{SCK}$  pin input) of the serial clock.
  - b. Trailing edge

Data is shifted at the trailing edge (the rising edge of  $\overline{SCK}$  pin input) of the serial clock. However, in the transmit mode, the trailing-edge shift is not supported.

### 3.7.4 Transfer bit number

SBIT (bit 2 of the command register 1) can select 4-bit/8-bit serial transfer.

- (1) 4-bit serial transfer

In this mode, transmission/reception is performed on 4-bit basis. ISIO interrupt is generated every 4-bit transfer. Transmit/receive data is written/read by accessing the buffer register (OP0F/IP0F) respectively.
- (2) 8-bit serial transfer

In this mode, transmission/reception is performed on 8-bit basis. ISIO interrupt is generated every 8-bit transfer. Transmit /receive data is written / read by accessing the buffer register (OPP0F / IP0F) twice.  
At the first access after setting transfer mode or generating the interrupt request, the write/read operation of lower 4-bit is performed to from the buffer register. At the second access, that of upper 4-bit is performed.

### 3.7.5 Transfer modes

Selection between the transmit mode, the receive mode (at transferring 4 bit) and the transmit and receive mode (at transferring 8 bit) is performed by RM (bit 2 of the command register 2).

#### (1) Transmit mode

The transmit mode is set to the command register than writes the first transmit data (4 bits or 8 bits) is written to the buffer register (OP0F). (If the transmit mode is not set, the data is not written to the buffer register). In the 8-bit transfer mode, the 8-bit data is written by accessing the buffer register (OP0F) twice. The transmit data is written after the 8-bit transfer mode is set or an interrupt request occurs: the lower 4 bits are written by the first access and the upper 4 bits by the next access. Then, setting ESIO to "1" starts transmission. The transmit data is output to the SO pin in synchronization with the serial clock from the LSB side sequentially. When the LSB is output, the transmit data is moved from the buffer register to the shift register. When the buffer register becomes empty, the buffer empty interrupt (ISIO) to request for the next transmit data is generated. In the interrupt service program, when the next transmit data is written to the buffer register, the interrupt request is reset.

In the operation based on the internal clock, if no more data is set after the transmission of the 4-bit or 8-bit data, the serial clock is stopped and the wait state sets in. In the operation based on the external clock, the data must be set in the buffer register by the time the next data shift operation starts. Therefore, the transfer rate is determined by the maximum delay time between the occurrence of the interrupt request and the writing of data to the buffer register by the interrupt serviced program.

To end transmission, ESIO is cleared to "0" instead of writing the next transmit data by the buffer empty interrupt service program. When ESIO is cleared, transmission stops upon termination of the currently shifted-out data. The transmission end can be known by the SIOF state (SIOF goes "0" upon transmission end). In the operation based on the external clock, ESIO must be cleared to "0" before the next data is shifted out. If ESIO is not cleared before, the transmission stops upon sending the next 4-bit or 8-bit data (dummy).

Example: To transmit (8-bit serial transfer) data stored in data memory (its address is specified by the HL register pair and the DMB) in synchronization with the internal clock ( $f_c/27$ ).

```
LD    A, #0101B ; OP1E ← 0101B (Sets the 8-bit serial transfer)
OUT   A, %OP1E
LD    A, #0010B ; OP1F ← 0010B (Sets the transmit mode)
OUT   A, %OP1F
OUT   @HL, %OP0F ; OP0F ← RAM [HL] (Writes the lower 4-bit data)
INC   L
OUT   @HL, %OP0F ; OP0F ← RAM [HL] (Writes the upper 4-bit data)
LD    A, #1010B ; ESIO ← 1 (Instructs transmission start)
OUT   A, %OP1F
```

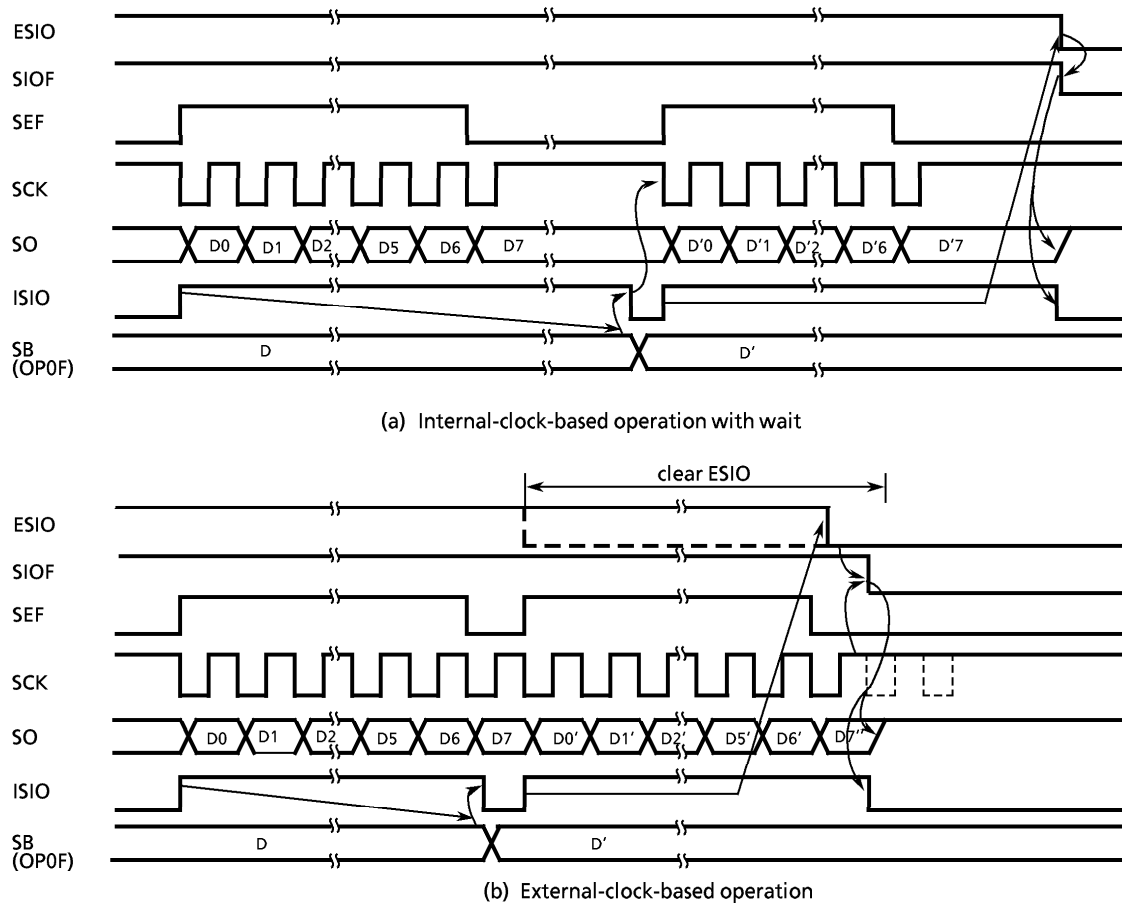

Figure 3-33. Transmit mode

## (2) 4-bit receive mode

Data can be received when ESIO is set to "1" after setting the receive mode to the command register. The data is put from the SI pin to the shift register in synchronization with the serial clock. Then the 4/8-bit data is transferred from the shift register to the buffer register (IPOF), upon which the (buffer full) interrupt (ISIO) to request for reading received data is generated. The receive data is read from the buffer register by the interrupt service program. When the data has been read, the interrupt request is reset and the next data is put in the shift register to be transferred to the buffer register. In the operation based on the internal clock, if the previous receive data has not been read from the buffer register at the end of capturing the next data, the serial clock is stopped and the wait operation is performed until the data has been read. In the operation based on the external clock, the shift operation is performed in synchronization with the externally-supplied clock, so that the data must be read from the buffer register before the next receive data is transferred to it. The maximum transfer rate in the external-clock-based operation is determined by the maximum delay time between the generation of interrupt request and the reading of receive data. In the receive mode, the shift operation may be performed at either the leading edge or the trailing edge. In the leading edge shift operation, data is captured at the leading edge of the serial clock, so that the first shift data must be put in the SI pin before the first serial clock is applied at the start of transfer.

To end the receive operation, ESIO must be cleared to "0". When ESIO is cleared, the completion of the transfer of the current 4-bit data to the buffer register terminates the receive operation. To confirm the end of the receive operation by program, SIOF (bit 3 of the status register) must be sensed. SIOF goes "0" upon the end of receive operation.

Note: If the transfer modes are changed, the contents of the buffer register are lost. Therefore, the modes should not be changed until the last received data is read even after the end of reception is instructed (by clearing ESIO to "0").

The receive operation can be terminated in one of the following approaches determined by the transfer rate:

- a. When the transfer rate is sufficiently low (the external-clock-based operation):  
If ESIO can be cleared to "0" before the next serial clock is applied upon occurrence of buffer full interrupt in the external-clock-based operation, ESIO is cleared to "0" by the interrupt service program, then the last received data is read.

Example: To instruct reception end when transfer rate is low (leading-edge shift).

```
LD      A,  #0110B      ; ESIO ← 0 (Instruct reception end)
OUT    A,  %OP1F
IN     %IPOF, A        ; Acc ← IPOF (Reads received data)
```

- b. When the transfer rate is high (the internal/external clock-based operation):  
If the transfer rate is high and, therefore, it is possible that the capture of the next data starts before ESIO is cleared to "0" upon acceptance of any interrupt, ESIO must be cleared to "0" by confirming that SEF (bit 2 of the status register) is set at reading the data proceeding the last data. Then, the data is read. In the interrupt servicing following the reception of the last data, no operation is needed for termination; only the reading of the received data is performed. This method is generally employed for the internal-clock-based operations. For an external-clock-based operation, ESIO must be cleared and the received data must be read before the last data is transferred to the buffer register.

Example: To instruct reception end when transfer rate is high (the internal clock, leading-edge shift).

```
SSEF0: TEST   %IPOE, 2      ; Waits until SEF = "1"
        B     SSEF0
        LD    A,  #0110B      ; ESIO ← 0
        OUT  A,  %OP1F
        IN   %IPOF, A        ; Acc ← IPOF (Reads received data)
```

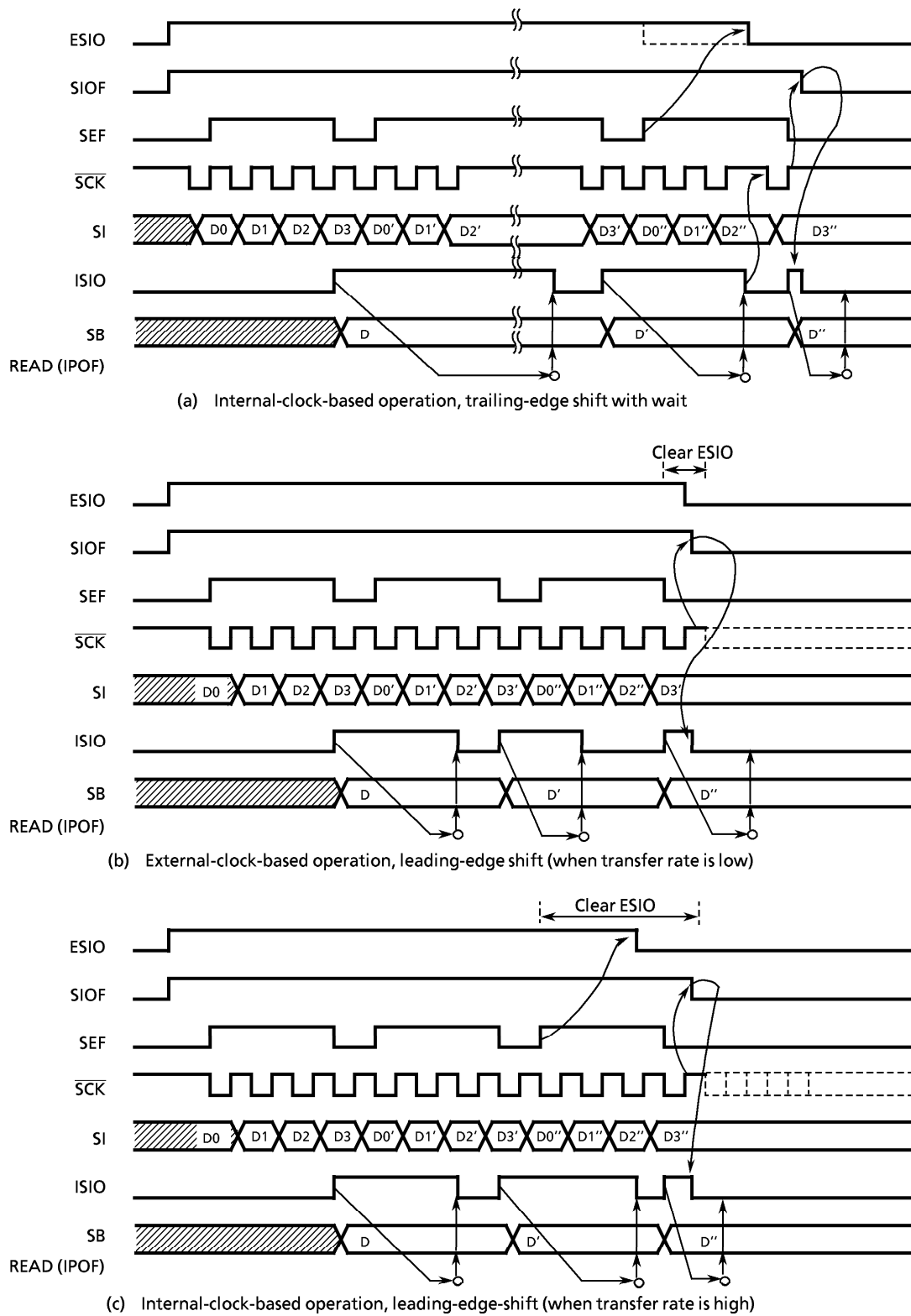

Figure3-34. 4-bit receive mode

## (3) 8-bit transmit/receive mode

After setting the transmission/reception mode to the command register, write first transmit data into the buffer register. Then, when "1" is set to ESIO, data transmission/reception becomes possible. The transmit data is output to the SO pin at the leading edge of serial clock and the receive data is input from the SI pin at the trailing edge. If the shift register is filled with the receive data, the data is transferred to the buffer register and ISIO (buffer full) interrupt is generated to request data read. The received data is read from the buffer register by the interrupt service program, and then write the transmit data to the buffer register.

Lower order 4 bits of both transmit and receive data are read/written from/into the buffer register by first access after setting of transmission/reception mode or generation of ISIO and higher 4 bits by next access.

In the operation based on the internal clock, SIO becomes the wait state until the received data are read out and the next data to be transmitted are written.

In the operation based on the external clock, the shift operation is synchronized with the external clock ; therefore, it is necessary to read the data received and to write data to be sent next before starting the next shift operation. The maximum transfer rate using an external clock is determined by the maximum delay time between the generation of the interrupt request and the writing of the data to be transmitted after the reading of the received data.

Also, the buffer register is used for both transmission and reception, therefore, the data must be written after reading 8 bits of receive data.

This operation is ended by clearing ESIO to "0". When ESIO is cleared, this operation is ended after transfer of the current 8 bits of data to the buffer register is completed. Programs can confirm that the operation has been completed by sensing SIOF (bit 3 of the status register) because SIOF is cleared to "0" when the operation is completed.

Example 1: To write data to be transmitted and to instruct the transmit/receive start.

```
LD      A, #0100B    ; Sets the 8-bit transfer and serial clock frequency.
OUT     A, %OP1E
LD      A, #0110B    ; Sets the transmit/receive mode of internal clock
                        operation
OUT     A, %OP1F
LD      HL, #20H     ; OP0F←RAM[20H] (Writes lower 4-bit data to be
                        transmitted)
OUT     @HL, %OP0F
INC     L            ; OP0F←RAM[21H] (Writes upper 4-bit data to be
                        transmitted)
OUT     @HL, %OP0F
LD      A, #1110B    ; ESIO ← 1 (Instructs serial transfer start)
OUT     A, %OP1F
      :              ; Data transfer
```

Example 2: To read data received and to write next data to be transmitted.

```
LD      HL, #30H     ; Stores lower 4-bit data received in RAM[30H].
IN      %IPOF, @HL
INC     L            ; Stores upper 4-bit received in RAM[31H].
IN      %IPOF, @HL
LD      HL, #22H     ; Writes next lower 4-bit data to be transmitted.
OUT     @HL, %OP0F
INC     L            ; Writes next upper 4-bit data to be transmitted.
OUT     @HL, %OP0F
```



### 3.7.6 Stopping serial transfer

A serial transfer operation can be stopped forcibly.

It is stopped by setting INH (bit 3 of command register 1) to "1", clearing the shift counter. When the serial transfer is over, INH is automatically cleared to "0" with no other bits of command register affected. In the transmit mode of this case,  $\overline{SCK}$  and SO output are initialized to "H" level whereas the shift register is not cleared. Therefore, after the resumption of transmit, SO holds the data just before forcible stop via the shift register until the 1st shift data comes to SO.

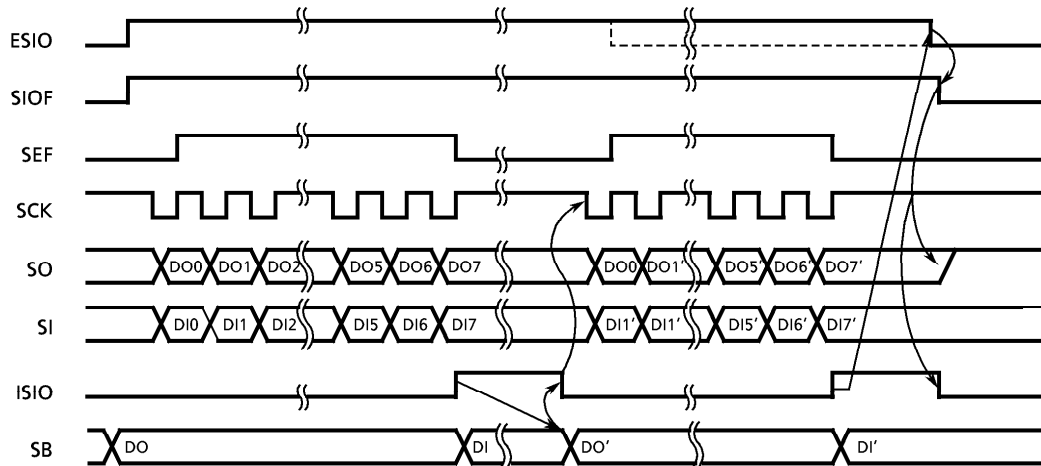

(a) Internal clock based operation with lwait

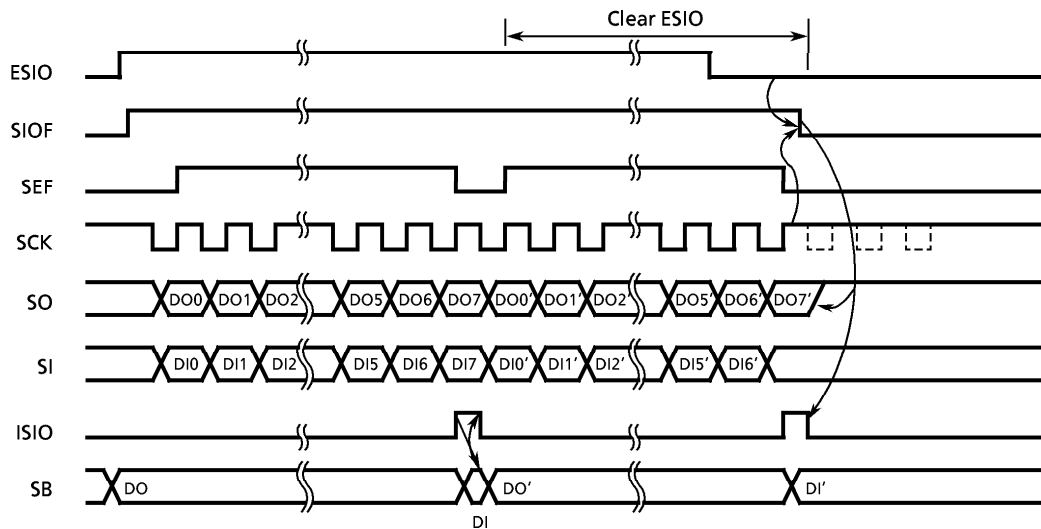

(b) External clock based operation

Figure3-35. 8-bit transmit/receive mode

### Port Condition by RESET Operation

The transition of Port condition by RESET operation is shown as below.

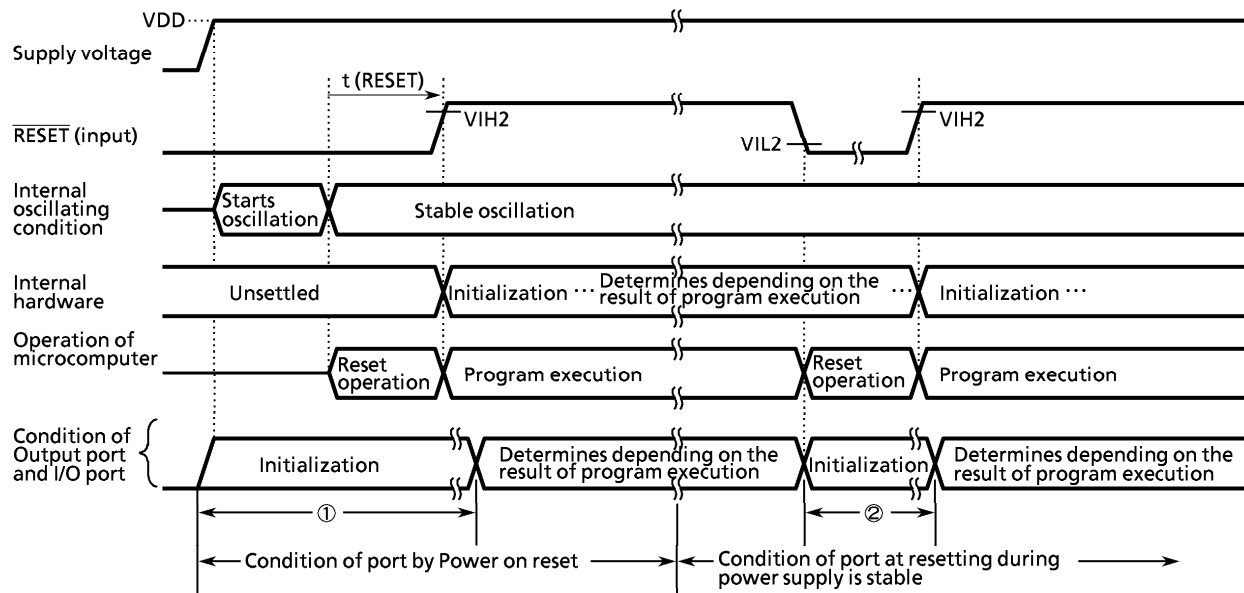

Figure 3-36. Port condition by Reset operation

Note 1:  $t(\text{RESET}) > 24/f_c$

Note 2: VIL2: Stands for low level input voltage of  $\overline{\text{RESET}}$  pin.

VIH2: Stands for high level input voltage of  $\overline{\text{RESET}}$  pin.

Note 3: The term from power on reset to the time program is executed (above ①) and also the term starting from reset operation during power supply is stable to the program is executed (above ②), the port is on the initial condition. The initial condition of Port differs from I/O circuit by each port, refer to the section of "INPUT/OUTPUT CIRCUITRY". Thus, when using Port as an output pin, in the term of the above ① and ②, the voltage level on the signal that connects with the output pin of Port to the input pin of external application circuit should be determined by the external circuitry such as pull-up resistor and / or pull-down resistor.

Input / Output Circuitry

(1) Control pins

The input / output circuitries of the TMP47C660A/860A control pins are shown below.

Control Pin	I/O	Circuitry	Remarks
XIN XOUT	Input Output		Resonator connecting pins $R = 1\text{ k}\Omega$ (typ.) $R_f = 1.5\text{ M}\Omega$ (typ.) $R_0 = 2\text{ k}\Omega$ (typ.)
XTIN XTOUT	Input Output		Resonator connecting pins $R = 1\text{ k}\Omega$ (typ.) $R_{fs} = 6\text{ M}\Omega$ (typ.) $R_0 = 220\text{ k}\Omega$ (typ.)
RESET	Input		Hysteresis input Pull-up resistor $R_{IN} = 220\text{ k}\Omega$ (typ.) $R = 1\text{ k}\Omega$ (typ.)
$\overline{\text{HOLD}}$ (KE0)	Input (Input)		Hysteresis input (Sense input) $R = 1\text{ k}\Omega$ (typ.)
TEST	Input		Pull-down resistor $R_{IN} = 70\text{ k}\Omega$ (typ.) $R = 1\text{ k}\Omega$ (typ.)

(2) I/O ports

The input/output circuitries of the TMP47C660A/860A I/O ports are shown below, any one of the circuitries can be chosen by a code (IA-IC) as a mask option.

Port	I/O	Input / Output Circuitry and Code			Remarks
		IA	IB	IC	
K0	Input				Pull-up / pull-down resistor  $R_{IN} = 70\text{ k}\Omega$ (typ.) $R = 1\text{ k}\Omega$ (typ.)
P0 P3	Output				Push-pull output Initial "Low" High current $I_{OL} = 7\text{ mA}$ (typ.)
P1 P2	Output				Sink open drain output Initial "Hi-Z" High current $I_{OL} = 20\text{ mA}$ (typ.)
R4 R5 R6 R7	I/O				Sink open drain output Initial "Hi-Z" $R = 1\text{ k}\Omega$ (typ.) Analog inputs (R4, R5) $R_A = 5\text{ k}\Omega$ (typ.) $C_A = 12\text{ pF}$ (typ.)
R8 R9	I/O				Sink open drain output Initial "Hi-Z"  Hysteresis input $R = 1\text{ k}\Omega$ (typ.)
RA RB RC	I/O				Push-pull output Initial "High"  $R = 1\text{ k}\Omega$ (typ.)

## Electrical Characteristics

Absolute Maximum Ratings (V<sub>SS</sub> = 0 V)

Parameter	Symbol	Pins	Ratings	Unit
Supply Voltage	V <sub>DD</sub>		- 0.3 to 6.5	V
Input Voltage	V <sub>IN</sub>		- 0.3 to V <sub>DD</sub> + 0.3	V
Output Voltage	V <sub>OUT</sub>		- 0.3 to V <sub>DD</sub> + 0.3	V
Output Current (per 1 pin)	I <sub>OUT1</sub>	Ports R	3.2	mA
	I <sub>OUT2</sub>	Ports P1, P2	30	
	I <sub>OUT3</sub>	Ports P0, P3	15	
Output Current (total)	∑ I <sub>OUT1</sub>	Ports P0, P1	120	mA
	∑ I <sub>OUT2</sub>	Ports P2, P3		
Power Dissipation [T <sub>opr</sub> = 70°C]	PD		600	mW
Soldering Temperature (time)	T <sub>sld</sub>		260 (10 s)	°C
Storage Temperature	T <sub>stg</sub>		- 55 to 125	°C
Operating Temperature	T <sub>opr</sub>		- 40 to 70	°C

**Note:** The absolute maximum ratings are rated values which must not be exceeded during operation, even for an instant. Any one of the ratings must not be exceeded. If any absolute maximum rating is exceeded, a device may break down or its performance may be degraded, causing it to catch fire or explode resulting in injury to the user. Thus, when designing products which include this device, ensure that no absolute maximum rating value will ever be exceeded.

Recommended Operating Conditions (V<sub>SS</sub> = 0 V, T<sub>opr</sub> = - 40 to 70°C)

Parameter	Symbol	Pins	Conditions	Min	Max	Unit
Supply Voltage	V <sub>DD</sub>		In the Normal mode	4.5	5.5	V
			In the SLOW mode	2.7		
			In the HOLD mode	2.0		
Input High Voltage	V <sub>IH1</sub>	Except Hysteresis Input	V <sub>DD</sub> ≥ 4.5 V	V <sub>DD</sub> × 0.7	V <sub>DD</sub>	V
	V <sub>IH2</sub>	Hysteresis Input		V <sub>DD</sub> × 0.75		
	V <sub>IH3</sub>		V <sub>DD</sub> < 4.5 V	V <sub>DD</sub> × 0.9		
Input Low Voltage	V <sub>IL1</sub>	Except Hysteresis Input	V <sub>DD</sub> ≥ 4.5 V	0	V <sub>DD</sub> × 0.3	V
	V <sub>IL2</sub>	Hysteresis Input			V <sub>DD</sub> × 0.25	
	V <sub>IL3</sub>		V <sub>DD</sub> < 4.5 V		V <sub>DD</sub> × 0.1	
Clock Frequency	f <sub>c</sub>	XIN, XOUT		0.4	6.0	MHz
	f <sub>s</sub>	XTIN, XTOUT		30	34	kHz

**Note 1:** The recommended operating conditions for a device are operating conditions under which it can be guaranteed that the device will operate as specified. If the device is used under operating conditions other than the recommended operating conditions (supply voltage, operating temperature range, specified AC/DC values etc.), malfunction may occur. Thus, when designing products which include this device, ensure that the recommended operating conditions for the device are always adhered to.

**Note 2:** Input voltage V<sub>IH3</sub>, V<sub>IL3</sub>: In the SLOW or HOLD mode.

## DC Characteristics

(V<sub>SS</sub> = 0 V, T<sub>opr</sub> = -40 to 70°C)

Parameter	Symbol	Pins	Conditions	Min	Typ.	Max	Unit
Hysteresis Voltage	V <sub>HS</sub>	Hysteresis Input		—	0.7	—	V
Input Current	I <sub>IN1</sub>	Port K0, TEST, RESET, HOLD	V <sub>DD</sub> = 5.5 V,	—	—	±2	μA
	I <sub>IN2</sub>	Ports R (open drain)	V <sub>IN</sub> = 5.5 V / 0 V				
Low Input Current	I <sub>IL</sub>	Ports R (push-pull)	V <sub>DD</sub> = 5.5 V, V <sub>IN</sub> = 0.4 V	—	—	-2	mA
Input Resistance	R <sub>IN1</sub>	Port KO with pull-up/pull-down		30	70	150	kΩ
	R <sub>IN2</sub>	RESET		100	220	450	
Output Leakage Current	I <sub>LO</sub>	Ports (open drain)	V <sub>DD</sub> = 5.5 V, V <sub>OUT</sub> = 5.5 V	—	—	2	μA
Output High Voltage	V <sub>OH</sub>	Ports (push-pull)	V <sub>DD</sub> = 4.5 V, I <sub>OH</sub> = -200 μA	2.4	—	—	V
Output Low Voltage	V <sub>OL</sub>	Except XOUT, ports P	V <sub>DD</sub> = 4.5 V, I <sub>OL</sub> = 1.6 mA	—	—	0.4	
Output Low Current	I <sub>OL2</sub>	Ports P1, P2	V <sub>DD</sub> = 4.5 V, V <sub>OL</sub> = 1.0 V	—	30	—	mA
	I <sub>OL3</sub>	Ports P0, P3		—	13	—	
Supply Current (in the Normal mode)	I <sub>DD</sub>		V <sub>DD</sub> = 5.5 V f <sub>c</sub> = 4 MHz	—	3	6	mA
Supply Current (in the SLOW mode)	I <sub>DDs</sub>		V <sub>DD</sub> = 3.0 V f <sub>s</sub> = 32.768 kHz	—	30	60	μA
Supply Current (in the HOLD mode)	I <sub>DDH</sub>		V <sub>DD</sub> = 5.5 V	—	0.5	10	μA

Note 1: Typ. values show those at T<sub>opr</sub> = 25°C, V<sub>DD</sub> = 5 V.

Note 2: Input Current I<sub>IN1</sub>; The current through resistor is not included, when the input resistor (pull-up/pull-down) is contained.

Note 3: Supply Current I<sub>DD</sub>, I<sub>DDH</sub>; V<sub>IN</sub> = 5.3 V / 0.2 V

The K0 port is open when the input resistor is contained. The voltage applied to the R port is within the valid range.

Supply Current I<sub>DDs</sub>; V<sub>IN</sub> = 2.8 V / 0.2 V

Low frequency clock is only oscillated (connecting XTIN, XTOUT).

## AD Conversion Characteristics

(T<sub>opr</sub> = -40 to 70°C)

Parameter	Symbol	Conditions	Min	Typ.	Max	Unit
Analog Reference Voltage	V <sub>AREF</sub>		V <sub>DD</sub> - 1.5	—	V <sub>DD</sub>	V
	V <sub>ASS</sub>		V <sub>SS</sub>	—	1.5	
Analog Reference Voltage Range	ΔV <sub>AREF</sub>	V <sub>AREF</sub> - V <sub>ASS</sub>	2.5	—	—	V
Analog Input Voltage	V <sub>AIN</sub>		V <sub>ASS</sub>	—	V <sub>AREF</sub>	V
Analog Supply Current	I <sub>REF</sub>		—	0.5	1.0	mA
Nonlinearity Error		V <sub>DD</sub> = 4.5 to 5.5 V, V <sub>SS</sub> = 0.0 V V <sub>AREF</sub> = V <sub>DD</sub> ± 0.001 V V <sub>ASS</sub> = 0.000 V	—	—	±1	LSB
Zero Point Error			—	—	±1	
Full Scale Error			—	—	±1	
Total Error			—	—	±2	

AC Characteristics

(V<sub>SS</sub> = 0 V, V<sub>DD</sub> = 4.5 to 5.5 V, Topr = -40 to 70°C)

Parameter	Symbol	Conditions	Min	Typ.	Max	Unit
Instruction Cycle Time	t <sub>cy</sub>	In the Normal mode	1.3	—	20	ns
		In the SLOW mode	235	—	267	
High level Clock pulse Width	t <sub>WCH</sub>	External clock mode	80	—	—	ns
Low level Clock pulse Width	t <sub>WCL</sub>					
AD Sampling Time	t <sub>AIN</sub>	f <sub>c</sub> = 4 MHz	—	4	—	μs
Shift Data Hold Time	t <sub>SDH</sub>		0.5 t <sub>cy</sub> - 0.3	—	—	μs

Note: Shift Data Hold Time

External circuit for  $\overline{SCK}$  pin and SO pin

Serial port (completion of transmission)

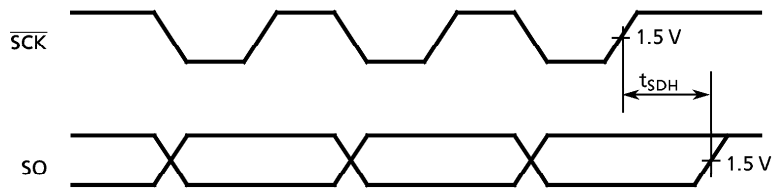
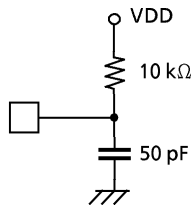

Recommended Oscillating Conditions

(V<sub>SS</sub> = 0 V, V<sub>DD</sub> = 4.5 to 5.5 V, Topr = -40 to 70°C)

(1) 6 MHz

Ceramic Resonator

CSA6.00MGU (MURATA) C<sub>XIN</sub> = C<sub>XOUT</sub> = 30 pF  
 KBR-6.00MS (KYOCERA) C<sub>XIN</sub> = C<sub>XOUT</sub> = 30 pF

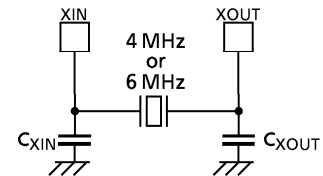

(2) 4 MHz

Ceramic Resonator

CSA4.00MG (MURATA) C<sub>XIN</sub> = C<sub>XOUT</sub> = 30 pF  
 KBR-4.00MS (KYOCERA) C<sub>XIN</sub> = C<sub>XOUT</sub> = 30 pF

Crystal Oscillator

204B-6F 4.0000 (TOYOCOM) C<sub>XIN</sub> = C<sub>XOUT</sub> = 20 pF

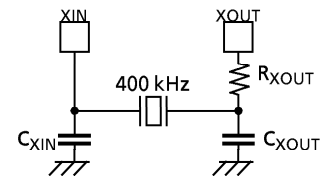

(3) 400 kHz

Ceramic Resonator

CSB400B (MURATA) C<sub>XIN</sub> = C<sub>XOUT</sub> = 220 pF, R<sub>XOUT</sub> = 6.8 kΩ  
 KBR-400B (KYOCERA) C<sub>XIN</sub> = C<sub>XOUT</sub> = 100 pF, R<sub>XOUT</sub> = 10 kΩ

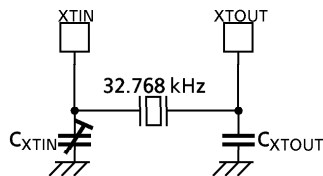

(4) 32.768 kHz (V<sub>SS</sub> = 0 V, V<sub>DD</sub> = 2.7 to 6.0V, Topr = -30 to 70°C)

Crystal Oscillator

C<sub>XTIN</sub>, C<sub>XTOUT</sub>; 10 to 33 pF

Note: In order to get the accurate oscillation frequency, the adjustment of capacitors must be required.

Typical Characteristics

