

ZHT431

Adjustable precision Zener shunt regulator

Description

The ZHT431 is a three terminal adjustable shunt regulator offering excellent temperature stability and output current handling capability up to 100mA. The device offers extended operating temperature range working from -55 to +125°C. The output voltage may be set to any chosen voltage between 2.5 and 20 volts by selection of two external divider resistors.

The devices can be used as a replacement for zener diodes in many applications requiring an improvement in zener performance.

Features

- Surface mount SOT223 and SOT23 packages
- 2% and 1% tolerance
- Maximum temperature coefficient 67 ppm/°C
- Temperature compensated for operation over the full temperature range
- Programmable output voltage
- 50µA to 100mA current sink capability
- Low output noise
- Wide temperature range -55 to +125°C

Applications

- Series and shunt regulator
- Voltage monitor
- Over voltage / under voltage protection
- Switch mode power supplies

Pinout information

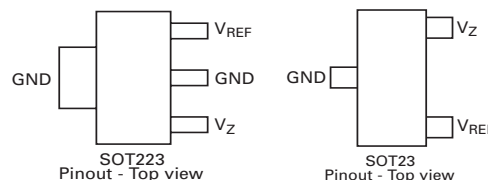

Ordering information

Order reference	Tolerance (%)	Package	Part mark	Status	Reel size (inches)	Quantity per reel	Tape width
ZHT431C01L	1	TO92	ZHT43101	Obsolete	Loose	4000	-
ZHT431C01STOB	1	TO92	ZHT43101	Obsolete	12.5	1500	-
ZHT431C01STZ	1	TO92	ZHT43101	Obsolete	Concertina	1500	-
ZHT431C02L	2	TO92	ZHT43102	Obsolete	Loose	4000	-
ZHT431C02STOB	2	TO92	ZHT43102	Obsolete	12.5	1500	-
ZHT431C02STZ	2	TO92	ZHT43102	Obsolete	Concertina	1500	-
ZHT431F01TA	1	SOT23	43C	Released	7	3000	8mm
ZHT431F02TA	2	SOT23	43D	Released	7	3000	8mm
ZHT431G01TA	1	SOT223	ZHT43101	Released	7	1000	12mm
ZHT431G02TA	2	SOT223	ZHT43102	Released	7	1000	12mm

ZHT431

Schematic diagram

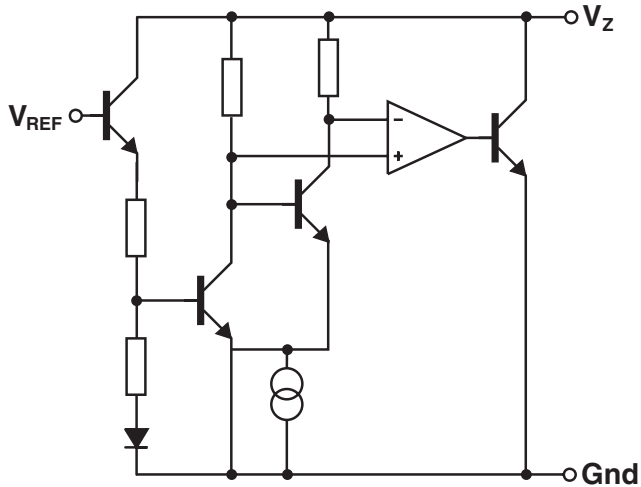

Absolute maximum rating

Cathode voltage (V_Z)	20V
Cathode current	150mA
Operating temperature	-55 to 125°C
Storage temperature	-55 to 150°C

Power dissipation ($T_{amb}=25^\circ\text{C}$)

($T_{jmax} = 150^\circ\text{C}$)

SOT23	330mW
TO92	780mW
SOT223	2W

Recommended operating conditions

	Min.	Max.
Cathode voltage	V_{REF}	20V
Cathode current	50 μA	100mA

Electrical characteristics test conditions (unless otherwise stated): $T_{amb}=25^{\circ}\text{C}$

Symbol	Parameter	Value			Units	Conditions	
		Min.	Typ.	Max.			
V_{REF}	Reference voltage	2%	2.45	2.50	2.55	V	$I_L=10\text{mA}$ (Fig.1), $V_Z=V_{REF}$
		1%	2.475	2.50	2.525	V	
V_{DEV}	Deviation of reference input voltage over temperature		10	30	mV	$I_L=10\text{mA}$, $V_Z=V_{REF}$ $T_{amb}=\text{full range}$ (Fig1)	
$\frac{\Delta V_{REF}}{\Delta V_Z}$	Ratio of the change in reference voltage to the change in cathode voltage		-1.85	-2.7	mV/V	V_Z from V_{REF} to 10V $I_Z=10\text{mA}$ (Fig.2)	
			-1.0	-2.0	mv/V	V_Z from 10V to 20V $I_Z=10\text{mA}$ (Fig.2)	
I_{REF}	Reference input current		0.12	1.0	μA	$R1=10\text{k}$, $R2=O/C$, $I_L=10\text{mA}$ (Fig.2)	
ΔI_{REF}	Deviation of reference input current over temperature		0.04	0.2	μA	$R1=10\text{k}$, $R2=O/C$, $I_L=10\text{mA}$ $T_{amb}=\text{full range}$ (Fig.2)	
I_{Zmin}	Minimum cathode current for regulation		35	50	μA	$V_Z=V_{REF}$ (Fig.1)	
I_{Zoff}	Off-state current			0.1	μA	$V_Z=20\text{V}$, $V_{REF}=0\text{V}$ (Fig.3)	
R_Z	Dynamic output impedance			0.75	Ω	$V_Z=V_{REF}$ (Fig.1), $f=0\text{Hz}$, $I_C=1\text{mA}$ to 100mA	

Deviation of reference input voltage, V_{DEV} , is defined as the maximum variation of the reference input voltage over the full temperature range.

The average temperature coefficient of the reference input voltage, V_{REF} is defined as:

$$V_{REF} \left(\frac{\text{ppm}}{^{\circ}\text{C}} \right) = \frac{V_{DEV} \times 1000000}{V_{REF} (T1 - T2)}$$

The dynamic output impedance, R_Z , is defined as:

$$R_Z = \frac{\Delta V_Z}{\Delta I_Z}$$

When the device is programmed with two external resistors, $R1$ and $R2$, (fig 2), the dynamic output impedance of the overall circuit, R' , is defined as:

$$R' = R_Z \left(1 + \frac{R1}{R2} \right)$$

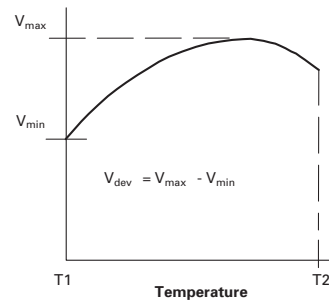

Typical characteristics

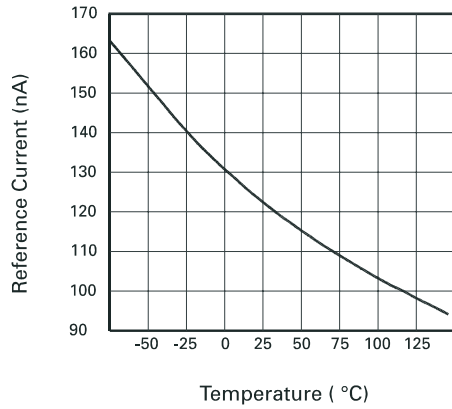

Iref vs. Temperature

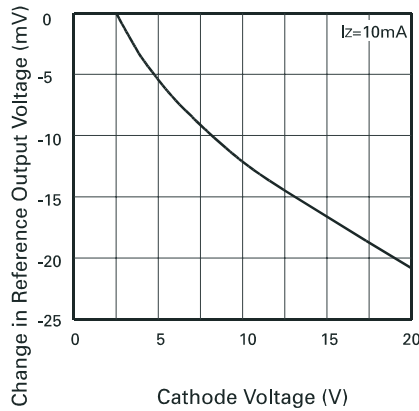

Change in Vref v Cathode Voltage

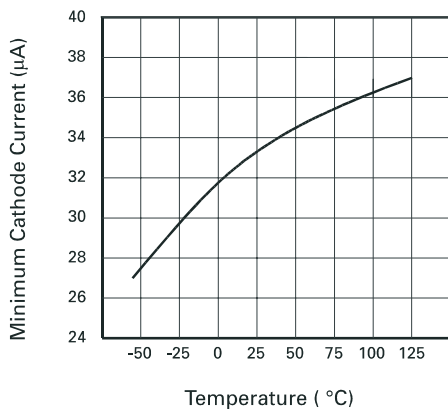

Izmin vs. Temperature

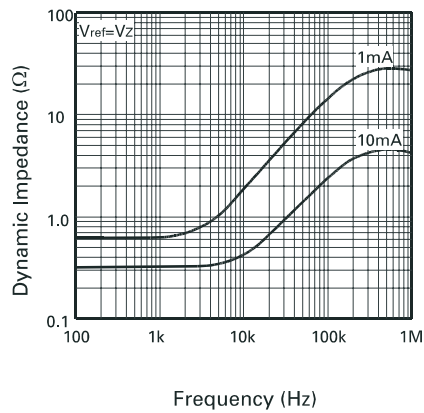

Dynamic Impedance v Frequency

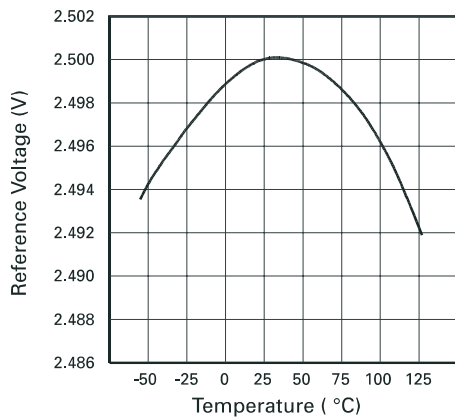

Vref vs. Temperature

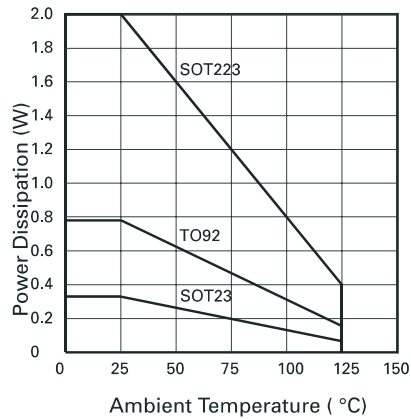

Power Dissipation Derating

Typical characteristics

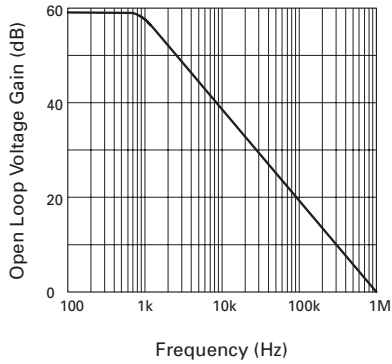

Gain v Frequency

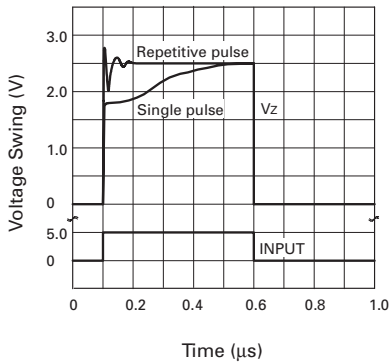

Pulse Response

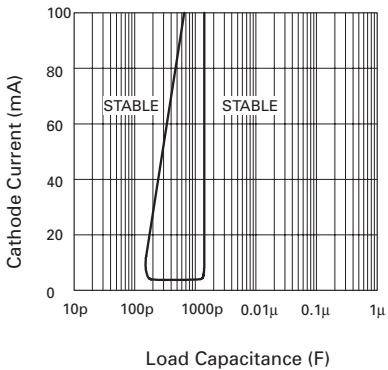

Stability Boundary Conditions

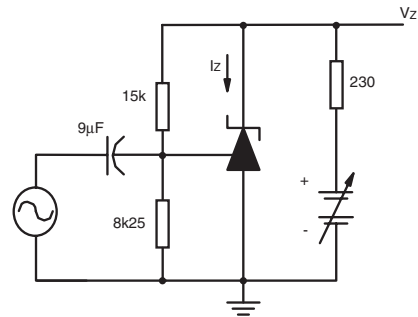

$I_Z = 10\text{mA}$, $T_A = 25^\circ\text{C}$

Test Circuit for Open Loop Voltage Gain

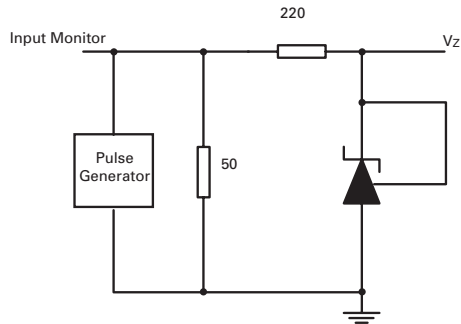

$T_A = 25^\circ\text{C}$

Test Circuit for Pulse Response

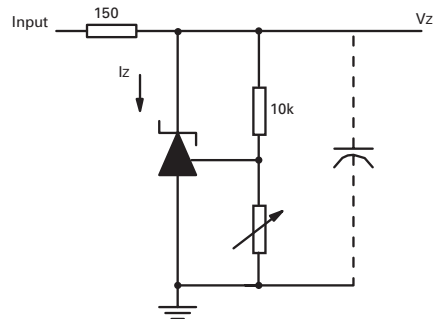

$V_{ref} < V_Z < 20$, $I_Z = 10\text{mA}$, $T_A = 25^\circ\text{C}$

Test Circuit for Stability Boundary Conditions

DC test circuits

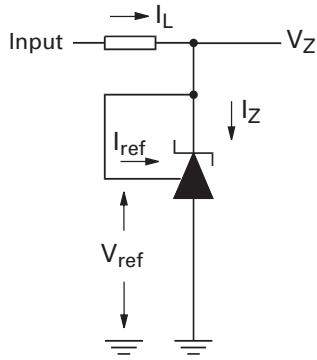

Fig 1 - Test circuit for $V_Z = V_{ref}$

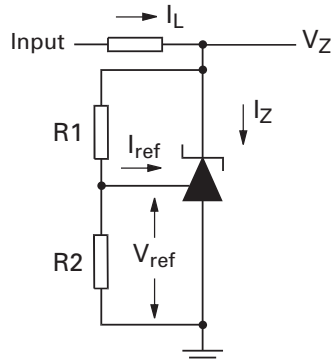

Fig 2 - Test circuit for $V_Z > V_{ref}$

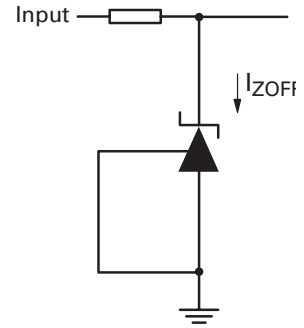
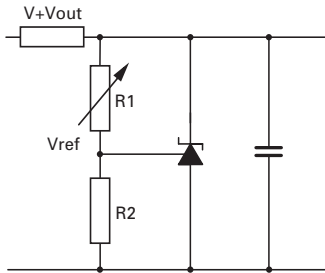

Fig 3 - Test circuit for for OI state current[†]

Application circuits



$$V_{out} = \left(1 + \frac{R1}{R2}\right) V_{ref}$$

Shunt regulator

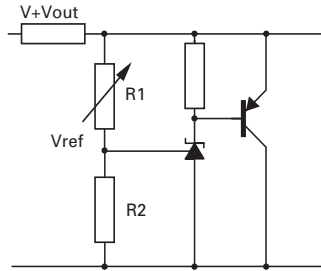

$$V_{out} = \left(1 + \frac{R1}{R2}\right) V_{ref}$$

Higher current shunt regulator

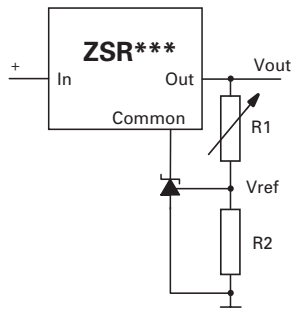

$$V_{out_MIN} = V_{ref} + V_{reg}$$

$$V_{out} = \left(1 + \frac{R1}{R2}\right) V_{ref}$$

Output control of a three terminal fixed regulator

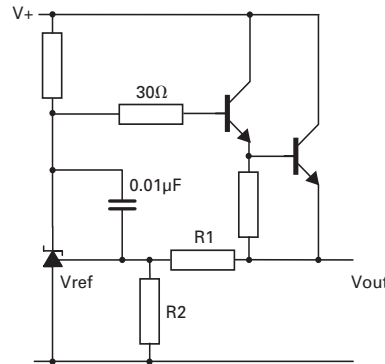

$$V_{out} = \left(1 + \frac{R1}{R2}\right) V_{ref}$$

Series regulator

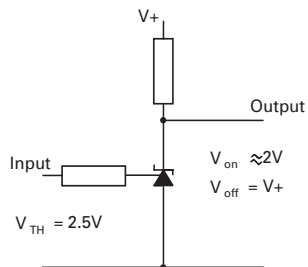

Single supply comparator with temperature compensated threshold

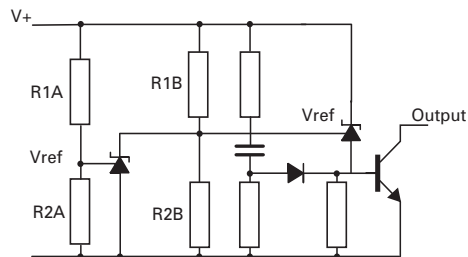

$$\text{Low limit} = \left(1 + \frac{R1B}{R2B}\right) V_{ref}$$

$$\text{High limit} = \left(1 + \frac{R1A}{R2A}\right) V_{ref}$$

Over voltage / under voltage protection circuit

ZHT431

Package outline - TO92

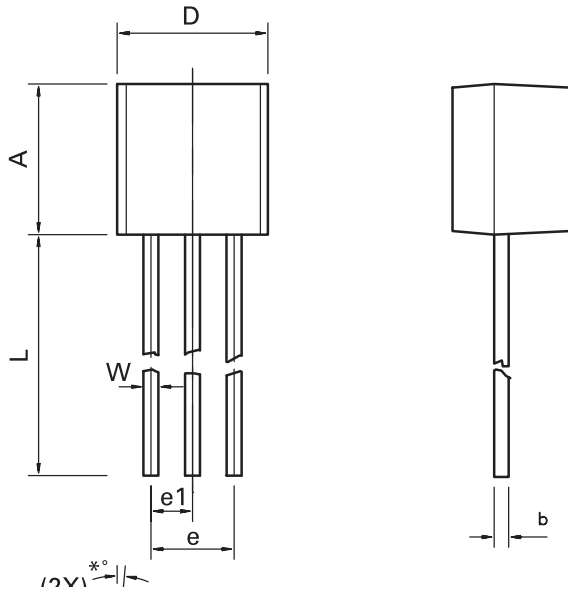

DIM	Millimeters		Inches	
	Min.	Max.	Min.	Max.
A	4.32	4.95	0.170	0.195
b	0.36	0.51	0.014	0.020
E	3.30	3.94	0.130	0.155
e	2.41	2.67	0.095	0.105
e1	1.14	1.40	0.045	0.055
L	12.70	15.49	0.500	0.610
R	2.16	2.41	0.085	0.095
S1	1.14	1.52	0.045	0.060
W	0.41	0.56	0.016	0.022
D	4.45	4.95	0.175	0.195
*°	4°	6°	4°	6°

Note: Controlling dimensions are in millimeters. Approximate dimensions are provided in inches

ZHT431

Package outline - SOT23

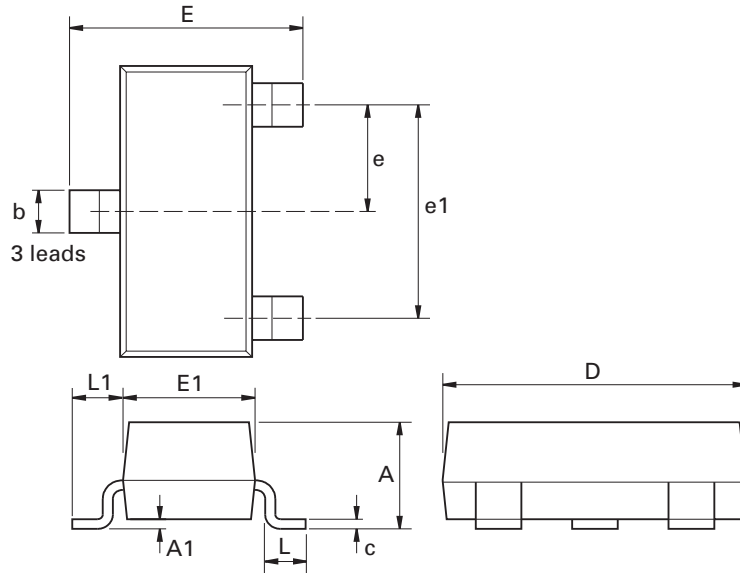

Dim.	Millimeters		Inches		Dim.	Millimeters		Inches	
	Min.	Max.	Min.	Max.		Min.	Max.	Max.	Max.
A	2.67	3.05	0.105	0.120	H	0.33	0.51	0.013	0.020
B	1.20	1.40	0.047	0.055	K	0.01	0.10	0.0004	0.004
C	-	1.10	-	0.043	L	2.10	2.50	0.083	0.0985
D	0.37	0.53	0.015	0.021	M	0.45	0.64	0.018	0.025
F	0.085	0.15	0.0034	0.0059	N	0.95 NOM		0.0375 NOM	
G	1.90 NOM		0.075 NOM		-	-	-	-	-

Note: Controlling dimensions are in millimeters. Approximate dimensions are provided in inches

ZHT431

Package outline - SOT223

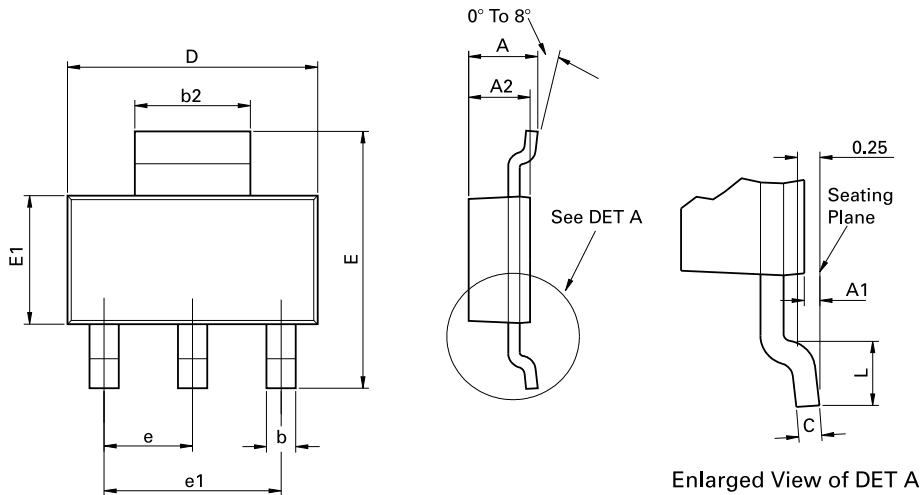

Conforms to JEDEC TO-261 AA Issue B

DIM	Millimeters		Inches		DIM	Millimeters		Inches	
	Min	Max	Min	Max		Min	Max	Min	Max
A	-	1.80	-	0.071	e	2.30 BSC		0.0905 BSC	
A1	0.02	0.10	0.0008	0.004	e1	4.60 BSC		0.181 BSC	
b	0.66	0.84	0.026	0.033	E	6.70	7.30	0.264	0.287
b2	2.90	3.10	0.114	0.122	E1	3.30	3.70	0.130	0.146
C	0.23	0.33	0.009	0.013	L	0.90	-	0.355	-
D	6.30	6.70	0.248	0.264	-	-	-	-	-

Note: Controlling dimensions are in millimeters. Approximate dimensions are provided in inches

Intentionally left blank

Definitions

Product change

Zetex Semiconductors reserves the right to alter, without notice, specifications, design, price or conditions of supply of any product or service. Customers are solely responsible for obtaining the latest relevant information before placing orders.

Applications disclaimer

The circuits in this design/application note are offered as design ideas. It is the responsibility of the user to ensure that the circuit is fit for the user's application and meets with the user's requirements. No representation or warranty is given and no liability whatsoever is assumed by Zetex with respect to the accuracy or use of such information, or infringement of patents or other intellectual property rights arising from such use or otherwise. Zetex does not assume any legal responsibility or will not be held legally liable (whether in contract, tort (including negligence), breach of statutory duty, restriction or otherwise) for any damages, loss of profit, business, contract, opportunity or consequential loss in the use of these circuit applications, under any circumstances.

Life support

Zetex products are specifically not authorized for use as critical components in life support devices or systems without the express written approval of the Chief Executive Officer of Zetex Semiconductors plc. As used herein:

A. Life support devices or systems are devices or systems which:

1. are intended to implant into the body

or

2. support or sustain life and whose failure to perform when properly used in accordance with instructions for use provided in the labeling can be reasonably expected to result in significant injury to the user.

B. A critical component is any component in a life support device or system whose failure to perform can be reasonably expected to cause the failure of the life support device or to affect its safety or effectiveness.

Reproduction

The product specifications contained in this publication are issued to provide outline information only which (unless agreed by the company in writing) may not be used, applied or reproduced for any purpose or form part of any order or contract or be regarded as a representation relating to the products or services concerned.

Terms and Conditions

All products are sold subjects to Zetex' terms and conditions of sale, and this disclaimer (save in the event of a conflict between the two when the terms of the contract shall prevail) according to region, supplied at the time of order acknowledgement.

For the latest information on technology, delivery terms and conditions and prices, please contact your nearest Zetex sales office or visit: www.zetex.com

Quality of product

Zetex is an ISO 9001 and TS16949 certified semiconductor manufacturer.

To ensure quality of service and products we strongly advise the purchase of parts directly from Zetex Semiconductors or one of our regionally authorized distributors. For a complete listing of authorized distributors please visit: www.zetex.com/salesnetwork

Zetex Semiconductors does not warrant or accept any liability whatsoever in respect of any parts purchased through unauthorized sales channels.

ESD (Electrostatic discharge)

Semiconductor devices are susceptible to damage by ESD. Suitable precautions should be taken when handling and transporting devices. The possible damage to devices depends on the circumstances of the handling and transporting, and the nature of the device. The extent of damage can vary from immediate functional or parametric malfunction to degradation of function or performance in use over time. Devices suspected of being affected should be replaced.

Green compliance

Zetex Semiconductors is committed to environmental excellence in all aspects of its operations which includes meeting or exceeding regulatory requirements with respect to the use of hazardous substances. Numerous successful programs have been implemented to reduce the use of hazardous substances and/or emissions.

All Zetex components are compliant with the RoHS directive, and through this it is supporting its customers in their compliance with WEEE and ELV directives.

Product status key:

"Preview"	Future device intended for production at some point. Samples may be available
"Active"	Product status recommended for new designs
"Last time buy (LTB)"	Device will be discontinued and last time buy period and delivery is in effect
"Not recommended for new designs"	Device is still in production to support existing designs and production
"Obsolete"	Production has been discontinued

Datasheet status key:

"Draft version"	This term denotes a very early datasheet version and contains highly provisional information, which may change in any manner without notice.
"Provisional version"	This term denotes a pre-release datasheet. It provides a clear indication of anticipated performance. However, changes to the test conditions and specifications may occur, at any time and without notice.
"Issue"	This term denotes an issued datasheet containing finalized specifications. However, changes to specifications may occur, at any time and without notice.

Zetex sales offices

Europe	Americas	Asia Pacific	Corporate Headquarters
Zetex GmbH Kustermann-park Balanstraße 59 D-81541 München Germany Telefon: (49) 89 45 49 49 0 Fax: (49) 89 45 49 49 49 europe.sales@zetex.com	Zetex Inc 700 Veterans Memorial Highway Hauppauge, NY 11788 USA Telephone: (1) 631 360 2222 Fax: (1) 631 360 8222 usa.sales@zetex.com	Zetex (Asia Ltd) 3701-04 Metroplaza Tower 1 Hing Fong Road, Kwai Fong Hong Kong Telephone: (852) 26100 611 Fax: (852) 24250 494 asia.sales@zetex.com	Zetex Semiconductors plc Zetex Technology Park, Chadderton Oldham, OL9 9LL United Kingdom Telephone: (44) 161 622 4444 Fax: (44) 161 622 4446 hq@zetex.com

© 2006 Published by Zetex Semiconductors plc