

# LM124A/LM124QML

## Low Power Quad Operational Amplifiers

### General Description

The LM124/124A consists of four independent, high gain, internally frequency compensated operational amplifiers which were designed specifically to operate from a single power supply over a wide range of voltages. Operation from split power supplies is also possible and the low power supply current drain is independent of the magnitude of the power supply voltage.

Application areas include transducer amplifiers, DC gain blocks and all the conventional op amp circuits which now can be more easily implemented in single power supply systems. For example, the LM124/124A can be directly operated off of the standard +5Vdc power supply voltage which is used in digital systems and will easily provide the required interface electronics without requiring the additional +15Vdc power supplies.

### Unique Characteristics

- In the linear mode the input common-mode voltage range includes ground and the output voltage can also swing to ground, even though operated from only a single power supply voltage
- The unity gain cross frequency is temperature compensated
- The input bias current is also temperature compensated

### Advantages

- Eliminates need for dual supplies
- Four internally compensated op amps in a single package
- Allows directly sensing near GND and  $V_{OUT}$  also goes to GND
- Compatible with all forms of logic
- Power drain suitable for battery operation

### Features

- Internally frequency compensated for unity gain
- Large DC voltage gain 100 dB
- Wide bandwidth (unity gain) 1 MHz (temperature compensated)
- Wide power supply range:  
Single supply 3V to 32V  
or dual supplies  $\pm 1.5V$  to  $\pm 16V$
- Very low supply current drain (700  $\mu A$ )—essentially independent of supply voltage
- Low input biasing current 45 nA (temperature compensated)
- Low input offset voltage 2 mV and offset current: 5 nA
- Input common-mode voltage range includes ground
- Differential input voltage range equal to the power supply voltage
- Large output voltage swing 0V to  $V^+ - 1.5V$

### Ordering Information

NS PART NUMBER	SMD PART NUMBER	NS PACKAGE NUMBER	PACKAGE DISCRIPTION
LM124J/883	7704301CA	J14A	14LD CERDIP
LM124AE/883	77043022A	E20A	20LD LEADLESS CHIP CARRIER
LM124AJ/883	7704302CA	J14A	14LD CERDIP
LM124AW/883		W14B	14LD CERPACK
LM124AWG/883	7704302XA	WG14A	14LD CERAMIC SOIC
LM124AJLQMLV	5962L9950401VCA, 50k rd(Si)	J14A	14LD CERDIP
LM124AJRQMLV	5962R9950401VCA, 100k rd(Si)	J14A	14LD CERDIP
LM124AWGLQMLV	5962L9950401VZA, 50k rd(Si)	WG14A	14LD CERAMIC SOIC
LM124AWGRQMLV	5962R9950401VZA, 100k rd(Si)	WG14A	14LD CERAMIC SOIC
LM124AWLQMLV	5962L9950401VDA, 50k rd(Si)	W14B	14LD CERPACK
LM124AWRQMLV	5962R9950401VDA, 100k rd(Si)	W14B	14LD CERPACK

## Connection Diagrams

**Leadless Chip Carrier**

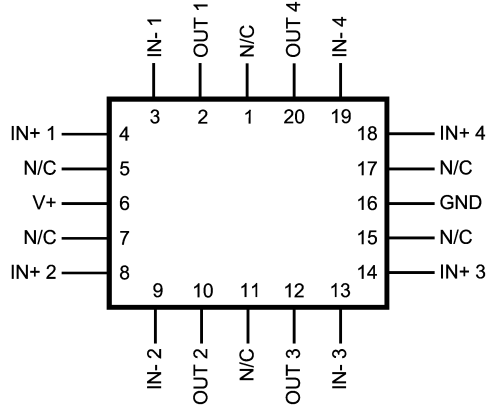

20108055

See NS Package Number E20A

**Dual-In-Line Package**

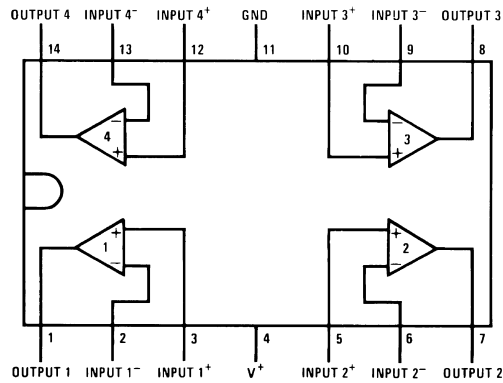

20108001

**Top View**

See NS Package Number J14A

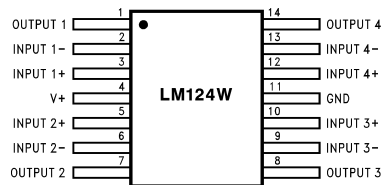

20108033

See NS Package Number W14B or WG14A

**Schematic Diagram** (Each Amplifier)

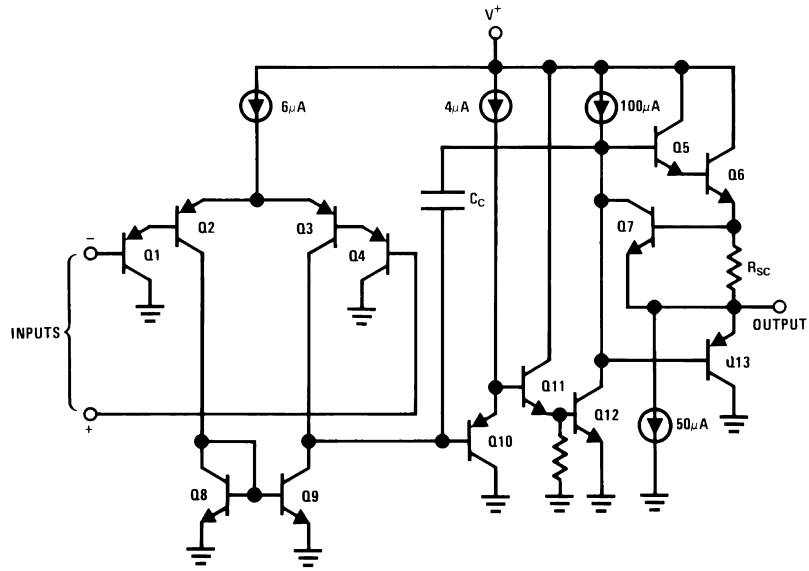

20108002

## Absolute Maximum Ratings (Note 1)

If Military/Aerospace specified devices are required, please contact the National Semiconductor Sales Office/Distributors for availability and specifications.

Supply Voltage, V <sup>+</sup>	32Vdc or +16Vdc
Differential Input Voltage	32Vdc
Input Voltage	-0.3Vdc to +32Vdc
Input Current	
(V <sub>IN</sub> < -0.3Vdc) (Note 4)	50 mA
Power Dissipation (Note 2)	
CERDIP	1260mW
CERPACK	700mW
LCC	1350mW
CERAMIC SOIC	700mW
Output Short-Circuit to GND	
(One Amplifier) (Note 3)	
V <sup>+</sup> ≤ 15Vdc and T <sub>A</sub> = 25°C	Continuous
Operating Temperature Range	-55°C ≤ T <sub>A</sub> ≤ +125°C
Maximum Junction Temperature	150°C
Storage Temperature Range	-65°C ≤ T <sub>A</sub> ≤ +150°C
Lead Temperature (Soldering, 10 seconds)	260°C
Thermal Resistance ThetaJA	
<b>CERDIP</b> (Still Air)	103 C/W
(500LF/Min Air flow)	51 C/W
<b>CERPACK</b> (Still Air)	176 C/W
(500LF/Min Air flow)	116 C/W
<b>LCC</b> (Still Air)	91 C/W
(500LF/Min Air flow)	66 C/W
<b>CERAMIC SOIC</b> (Still Air)	176 C/W
(500LF/Min Air flow)	116 C/W
ThetaJC	
CERDIP	19 C/W
CERPACK	18 C/W
LCC	24 C/W
CERAMIC SOIC	18 C/W
Package Weight (Typical)	
CERDIP	TBD
CERPACK	TBD
LCC	TBD
CERAMIC SOIC	410mg
ESD Tolerance (Note 5)	250V

**Note 1:** Absolute Maximum Ratings indicate limits beyond which damage to the device may occur. Operating Ratings indicate conditions for which the device is functional, but do not guarantee specific performance limits. For guaranteed specifications and test conditions, see the Electrical Characteristics. The guaranteed specifications apply only for the test conditions listed. Some performance characteristics may degrade when the device is not operated under the listed test conditions.

**Note 2:** The maximum power dissipation must be derated at elevated temperatures and is dictated by T<sub>jmax</sub> (maximum junction temperature), ThetaJA (package junction to ambient thermal resistance), and T<sub>A</sub> (ambient temperature). The maximum allowable power dissipation at any temperature is P<sub>dmax</sub> = (T<sub>jmax</sub> - T<sub>A</sub>)/ThetaJA or the number given in the Absolute Maximum Ratings, whichever is lower.

**Note 3:** Short circuits from the output to V<sup>+</sup> can cause excessive heating and eventual destruction. When considering short circuits to ground, the maximum output current is approximately 40mA independent of the magnitude of V<sup>+</sup>. At values of supply voltage in excess of +15Vdc, continuous short-circuits can exceed the power dissipation ratings and cause eventual destruction. Destructive dissipation can result from simultaneous shorts on all amplifiers.

**Note 4:** This input current will only exist when the voltage at any of the input leads is driven negative. It is due to the collector-base junction of the input PNP transistors becoming forward biased and thereby acting as input diode clamps. In addition to this diode action, there is also lateral NPN parasitic transistor action on the IC chip. This transistor action can cause the output voltages of the op amps to go to the V<sup>+</sup> voltage level (or to ground for a large overdrive) for the time duration that an input is driven negative. This is not destructive and normal output states will re-establish when the input voltage, which was negative, again returns to a value greater than -0.3Vdc (at 25°C).

**Note 5:** Human body model, 1.5 kΩ in series with 100 pF.

## Quality Conformance Inspection

MIL-STD-883, Method 5005 — Group A

Subgroup	Description	Temp ( °C)
1	Static tests at	+25
2	Static tests at	+125
3	Static tests at	-55
4	Dynamic tests at	+25
5	Dynamic tests at	+125
6	Dynamic tests at	-55
7	Functional tests at	+25
8A	Functional tests at	+125
8B	Functional tests at	-55
9	Switching tests at	+25
10	Switching tests at	+125
11	Switching tests at	-55

## LM124A 883 DC Electrical Characteristics

(The following conditions apply to all the following parameters, unless otherwise specified.) All voltages referenced to device ground.

SYMBOL	PARAMETER	CONDITIONS	NOTES	MIN	MAX	UNIT	SUB-GROUPS
I <sub>cc</sub>	Power Supply Current	V <sub>+</sub> = 5V			1.2	mA	1, 2, 3
		V <sub>+</sub> = 30V			3.0	mA	1
					4.0	mA	2, 3
I <sub>sink</sub>	Output Sink Current	V <sub>+</sub> = 15V, V <sub>out</sub> = 200mV, +V <sub>in</sub> = 0mV, -V <sub>in</sub> = +65mV		12		uA	1
		V <sub>+</sub> = 15V, V <sub>out</sub> = 2V, +V <sub>in</sub> = 0mV, -V <sub>in</sub> = +65mV		10		mA	1
				5		mA	2, 3
I <sub>source</sub>	Output Source Current	V <sub>+</sub> = 15V, V <sub>out</sub> = 2V, +V <sub>in</sub> = 0mV, -V <sub>in</sub> = -65mV			-20	mA	1
					-10	mA	2, 3
I <sub>os</sub>	Short Circuit Current	V <sub>+</sub> = 5V, V <sub>out</sub> = 0V		-60		mA	1
V <sub>io</sub>	Input Offset Voltage	V <sub>+</sub> = 30V, V <sub>cm</sub> = 0V		-2	2	mV	1
				-4	4	mV	2, 3
		V <sub>+</sub> = 30V, V <sub>cm</sub> = 28.5V		-2	2	mV	1
				-4	4	mV	2, 3
		V <sub>+</sub> = 5V, V <sub>cm</sub> = 0V		-2	2	mV	1
				-4	4	mV	2, 3
CMRR	Common Mode Rejection Ratio	V <sub>+</sub> = 30V, V <sub>in</sub> = 0V to 28.5V		70		dB	1
±I <sub>lib</sub>	Input Bias Current	V <sub>+</sub> = 5V, V <sub>cm</sub> = 0V		-50	10	nA	1
				-100	10	nA	2, 3
I <sub>io</sub>	Input Offset Current	V <sub>+</sub> = 5V, V <sub>cm</sub> = 0V		-10	10	nA	1
				-30	30	nA	2, 3
PSRR	Power Supply Rejection Ratio	V <sub>+</sub> = 5V to 30V, V <sub>cm</sub> = 0V		65		dB	1
V <sub>cm</sub>	Common Mode Voltage Range	V <sub>+</sub> = 30V	(Note 6)		28.5	V	1
			(Note 6)		28	V	2, 3
A <sub>vs</sub>	Large Signal Gain	V <sub>+</sub> = 15V, R <sub>I</sub> = 2K Ohms, V <sub>o</sub> = 1V to 11V	(Note 7)	50		V/mV	4
			(Note 7)	25		V/mV	5, 6
V <sub>oh</sub>	Output Voltage High	V <sub>+</sub> = 30V, R <sub>I</sub> = 2K Ohms		26		V	4, 5, 6
		V <sub>+</sub> = 30V, R <sub>I</sub> = 10K Ohms		27		V	4, 5, 6
V <sub>ol</sub>	Output Voltage Low	V <sub>+</sub> = 30V, R <sub>I</sub> = 10K Ohms			40	mV	4, 5, 6
		V <sub>+</sub> = 30V, I <sub>sink</sub> = 1uA			40	mV	4
					100	mV	5, 6
		V <sub>+</sub> = 5V, R <sub>I</sub> = 10K Ohms			20	mV	4, 5, 6
	Channel Separation Amp to Amp Coupling	1KHz, 20KHz	(Note 8)	80		dB	4

## LM124 883 DC Electrical Characteristics

(The following conditions apply to all the following parameters, unless otherwise specified.) All voltages referenced to device ground.

SYMBOL	PARAMETER	CONDITIONS	NOTES	MIN	MAX	UNIT	SUB-GROUPS	
I <sub>cc</sub>	Power Supply Current	V <sub>+</sub> = 5V			1.2	mA	1, 2, 3	
		V <sub>+</sub> = 30V			3.0	mA	1	
					4.0	mA	2, 3	
I <sub>sink</sub>	Output Sink Current	V <sub>+</sub> = 15V, V <sub>out</sub> = 200mV, +V <sub>in</sub> = 0mV, -V <sub>in</sub> = +65mV		12		uA	1	
		V <sub>+</sub> = 15V, V <sub>out</sub> = 2V, +V <sub>in</sub> = 0mV, -V <sub>in</sub> = +65mV		10		mA	1	
				5		mA	2, 3	
I <sub>source</sub>	Output Source Current	V <sub>+</sub> = 15V, V <sub>out</sub> = 2V, +V <sub>in</sub> = 0mV, -V <sub>in</sub> = -65mV			-20	mA	1	
					-10	mA	2, 3	
I <sub>os</sub>	Short Circuit Current	V <sub>+</sub> = 5V, V <sub>out</sub> = 0V		-60		mA	1	
V <sub>io</sub>	Input Offset Voltage	V <sub>+</sub> = 30V, V <sub>cm</sub> = 0V		-5	5	mV	1	
				-7	7	mV	2, 3	
		V <sub>+</sub> = 30V, V <sub>cm</sub> = 28V		-5	5	mV	1	
				-7	7	mV	2, 3	
		V <sub>+</sub> = 5V, V <sub>cm</sub> = 0V		-5	5	mV	1	
				-7	7	mV	2, 3	
		V <sub>+</sub> = 30V, V <sub>cm</sub> = 28.5V		-5	5	mV	1	
CMRR	Common Mode Rejection Ratio	V <sub>+</sub> = 30V, V <sub>in</sub> = 0V to 28.5V		70		dB	1	
+I <sub>ib</sub>	Input Bias Current	V <sub>+</sub> = 5V, V <sub>cm</sub> = 0V		-150	10	nA	1	
				-300	10	nA	2, 3	
I <sub>io</sub>	Input Offset Current	V <sub>+</sub> = 5V, V <sub>cm</sub> = 0V		-30	30	nA	1	
				-100	100	nA	2, 3	
PSRR	Power Supply Rejection Ratio	V <sub>+</sub> = 5V to 30V, V <sub>cm</sub> = 0V		65		dB	1	
V <sub>cm</sub>	Common Mode Voltage Range	V <sub>+</sub> = 30V	(Note 6)		28.5	V	1	
			(Note 6)		28	V	2, 3	
A <sub>vs</sub>	Large Signal Gain	V <sub>+</sub> = 15V, R <sub>I</sub> = 2K Ohms, V <sub>o</sub> = 1V to 11V		50		V/mV	4	
				25		V/mV	5, 6	
V <sub>oh</sub>	Output Voltage High	V <sub>+</sub> = 30V, R <sub>I</sub> = 2K Ohms		26		V	4, 5, 6	
		V <sub>+</sub> = 30V, R <sub>I</sub> = 10K Ohms		27		V	4, 5, 6	
V <sub>ol</sub>	Output Voltage Low	V <sub>+</sub> = 30V, R <sub>I</sub> = 10K Ohms			40	mV	4, 5, 6	
		V <sub>+</sub> = 30V, I <sub>sink</sub> = 1uA			40	mV	4	
						100	mV	5, 6
		V <sub>+</sub> = 5V, R <sub>I</sub> = 10K Ohms			20	mV	4, 5, 6	
	Channel Separation (Amp to Amp Coupling)	1KHz, 20KHz	(Note 8)	80		dB	4	

## LM124A RAD HARD DC Electrical Characteristics (Note 10)

(The following conditions apply to all the following parameters, unless otherwise specified.) **All voltages referenced to device ground.**

SYMBOL	PARAMETER	CONDITIONS	NOTES	MIN	MAX	UNIT	SUB-GROUPS
Vio	Input Offset Voltage	Vcc+ = 30V, Vcc- = Gnd, Vcm = -15V		-2	2	mV	1
				-4	4	mV	2, 3
		Vcc+ = 2V, Vcc- = -28V, Vcm = 13V		-2	2	mV	1
				-4	4	mV	2, 3
		Vcc+ = 5V, Vcc- = Gnd, Vcm = -1.4V		-2	2	mV	1
				-4	4	mV	2, 3
Vcc+ = 2.5V, Vcc- = -2.5, Vcm = 1.1V		-2	2	mV	1		
		-4	4	mV	2, 3		
Iio	Input Offset Current	Vcc+ = 30V, Vcc- = Gnd, Vcm = -15V		-10	10	nA	1, 2
				-30	30	nA	3
		Vcc+ = 2V, Vcc- = -28V, Vcm = 13V		-10	10	nA	1, 2
				-30	30	nA	3
		Vcc+ = 5V, Vcc- = Gnd, Vcm = -1.4V		-10	10	nA	1, 2
				-30	30	nA	3
Vcc+ = 2.5V, Vcc- = -2.5, Vcm = 1.1V		-10	10	nA	1, 2		
		-30	30	nA	3		
±lib	Input Bias Current	Vcc+ = 30V, Vcc- = Gnd, Vcm = -15V		-50	+0.1	nA	1, 2
				-100	+0.1	nA	3
		Vcc+ = 2V, Vcc- = -28V, Vcm = 13V		-50	+0.1	nA	1, 2
				-100	+0.1	nA	3
		Vcc+ = 5V, Vcc- = Gnd, Vcm = -1.4V		-50	+0.1	nA	1, 2
				-100	+0.1	nA	3
Vcc+ = 2.5V, Vcc- = -2.5, Vcm = 1.1V		-50	+0.1	nA	1, 2		
		-100	+0.1	nA	3		
+PSRR	Power Supply Rejection Ratio	Vcc- = Gnd, Vcm = -1.4V, 5V ≤ Vcc ≤ 30V		-100	100	uV/V	1, 2, 3
CMRR	Common Mode Rejection Ratio			76		dB	1, 2, 3
Ios+	Output Short Circuit Current	Vcc+ = 30V, Vcc- = Gnd, Vo = 25V		-70		mA	1, 2, 3
Icc	Power Supply Current	Vcc+ = 30V, Vcc- = Gnd			3	mA	1, 2
					4	mA	3
Delta Vio/ Delta T	Input Offset Voltage Temperature Sensitivity	+25°C ≤ TA ≤ +125°C, +Vcc = 5V, -Vcc = 0V, Vcm = -1.4V	(Note 9)	-30	30	uV/°C	2
		-55°C ≤ TA ≤ +25°C, +Vcc = 5V, -Vcc = 0V, Vcm = -1.4V	(Note 9)	-30	30	uV/°C	3
Delta Iio/ Delta T	Input Offset Current Temperature Sensitivity	+25°C ≤ TA ≤ +125°C, +Vcc = 5V, -Vcc = 0V, Vcm = -1.4V	(Note 9)	-400	400	pA/°C	2
		-55°C ≤ TA ≤ +25°C, +Vcc = 5V, -Vcc = 0V, Vcm = -1.4V	(Note 9)	-700	700	pA/°C	3



## LM124A RAD HARD AC/DC Electrical Characteristics (Note 10)

(The following conditions apply to all the following parameters, unless otherwise specified.) All voltages referenced to device ground.

SYMBOL	PARAMETER	CONDITIONS	NOTES	MIN	MAX	UNIT	SUB-GROUPS
Vol	Logical "0" Output Voltage	Vcc+ = 30V, Vcc- = Gnd, RI = 10K Ohms			35	mV	4, 5, 6
		Vcc+ = 30V, Vcc- = Gnd, Iol = 5mA			1.5	V	4, 5, 6
		Vcc+ = 4.5V, Vcc- = Gnd, Iol = 2uA			0.4	V	4, 5, 6
Voh	Logical "1" Output Voltage	Vcc+ = 30V, Vcc- = Gnd, Ioh = -10mA		27		V	4, 5, 6
		Vcc+ = 4.5V, Vcc- = Gnd, Ioh = -10mA		2.4		V	4, 5, 6
Avs+	Voltage Gain	Vcc+ = 30V, Vcc- = Gnd, 1V ≤ Vo ≤ 26V, RI = 10K Ohms		50		V/mV	4
				25		V/mV	5, 6
		Vcc+ = 30V, Vcc- = Gnd, 5V ≤ Vo ≤ 20V, RI = 2K Ohms		50		V/mV	4
				25		V/mV	5, 6
Avs	Voltage Gain	Vcc+ = 5V, Vcc- = Gnd, 1V ≤ Vo ≤ 2.5V, RI = 10K Ohms		10		V/mV	4, 5, 6
		Vcc+ = 5V, Vcc- = Gnd, 1V ≤ Vo ≤ 2.5V, RI = 2K Ohms		10		V/mV	4, 5, 6
+Vop	Maximum Output Voltage Swing	Vcc+ = 30V, Vcc- = Gnd, Vo = +30V, RI = 10K Ohms		27		V	4, 5, 6
		Vcc+ = 30V, Vcc- = Gnd, Vo = +30V, RI = 2K Ohms		26		V	4, 5, 6
TR(tr)	Transient Response: Rise Time	Vcc+ = 30V, Vcc- = Gnd			1	uS	7, 8A, 8B
TR(os)	Transient Response: Overshoot	Vcc+ = 30V, Vcc- = Gnd			50	%	7, 8A, 8B
±Sr	Slew Rate: Rise	Vcc+ = 30V, Vcc- = Gnd		0.1		V/uS	7, 8A, 8B
	Slew Rate: Fall	Vcc+ = 30V, Vcc- = Gnd		0.1		V/uS	7, 8A, 8B

**LM124A RAD HARD — AC Electrical Characteristics** (Note 10)(The following conditions apply to all the following parameters, unless otherwise specified.) **AC: +Vcc = 30V, -Vcc = 0V**

SYMBOL	PARAMETER	CONDITIONS	NOTES	MIN	MAX	UNIT	SUB-GROUPS
NI(BB)	Noise Broadband	+Vcc = 15V, -Vcc = -15V, BW = 10Hz to 5KHz			15	$\mu\text{Vrms}$	7
NI(PC)	Noise Popcorn	+Vcc = 15V, -Vcc = -15V, Rs = 20K Ohms, BW = 10Hz to 5KHz			50	$\mu\text{VpK}$	7
Cs	Channel Separation	+Vcc = 30V, -Vcc = Gnd, RI = 2K Ohms		80		dB	7
		RI = 2K Ohms, Vin = 1V and 16V, A to B		80		dB	7
		RI = 2K Ohms, Vin = 1V and 16V, A to C		80		dB	7
		RI = 2K Ohms, Vin = 1V and 16V, A to D		80		dB	7
		RI = 2K Ohms, Vin = 1V and 16V, B to A		80		dB	7
		RI = 2K Ohms, Vin = 1V and 16V, B to C		80		dB	7
		RI = 2K Ohms, Vin = 1V and 16V, B to D		80		dB	7
		RI = 2K Ohms, Vin = 1V and 16V, C to A		80		dB	7
		RI = 2K Ohms, Vin = 1V and 16V, C to B		80		dB	7
		RI = 2K Ohms, Vin = 1V and 16V, C to D		80		dB	7
		RI = 2K Ohms, Vin = 1V and 16V, D to A		80		dB	7
		RI = 2K Ohms, Vin = 1V and 16V, D to B		80		dB	7
		RI = 2K Ohms, Vin = 1V and 16V, D to C		80		dB	7

**LM124A RAD HARD — DC Drift Values** (Note 10)

(The following conditions apply to all the following parameters, unless otherwise specified.) DC: "Delta calculations performed on QMLV devices at group B, subgroup 5 only"

SYMBOL	PARAMETER	CONDITIONS	NOTES	MIN	MAX	UNIT	SUB-GROUPS
Vio	Input Offset Voltage	Vcc+ = 30V, Vcc- = Gnd, Vcm = -15V		-0.5	0.5	mV	1
±lib	Input Bias Current	Vcc+ = 30V, Vcc- = Gnd, Vcm = -15V		-10	10	nA	1

**Electrical Characteristics — POST RADIATION LIMITS +25°C** (Note 10)

(The following conditions apply to all the following parameters, unless otherwise specified.) All voltages referenced to device ground.

SYMBOL	PARAMETER	CONDITIONS	NOTES	MIN	MAX	UNIT	SUB-GROUPS
Vio	Input Offset Voltage	Vcc+ = 30V, Vcc- = Gnd, Vcm = -15V	(Note 10)	-2.5	2.5	mV	1
		Vcc+ = 2V, Vcc- = -28V, Vcm = 13V	(Note 10)	-2.5	2.5	mV	1
		Vcc+ = 5V, Vcc- = GND, Vcm = -1.4V	(Note 10)	-2.5	2.5	mV	1
		Vcc+ = 2.5V, Vcc- = -2.5, Vcm = 1.1V	(Note 10)	-2.5	2.5	mV	1
lio	Input Offset Current	Vcc+ = 30V, Vcc- = GND, Vcm = -15V	(Note 10)	-15	15	nA	1
		Vcc+ = 2V, Vcc- = -28V, Vcm = 13V	(Note 10)	-15	15	nA	1
		Vcc+ = 5V, Vcc- = GND, Vcm = -1.4V	(Note 10)	-15	15	nA	1
		Vcc+ = 2.5V, Vcc- = -2.5V, Vcm = 1.1V	(Note 10)	-15	15	nA	1
±lib	Input Bias Current	Vcc+ = 30V, Vcc- = GND, Vcm = -15V	(Note 10)	-75	+0.1	nA	1
		Vcc+ = 2V, Vcc- = -28V, Vcm = 13V	(Note 10)	-75	+0.1	nA	1
		Vcc+ = 5V, Vcc- = GND, Vcm = -1.4V	(Note 10)	-75	+0.1	nA	1
		Vcc+ = 2.5V, Vcc- = -2.5V, Vcm = 1.1V	(Note 10)	-75	+0.1	nA	1
Avs+	Voltage Gain	Vcc+ = 30V, Vcc- = GND, 1V ≤ Vo ≤ 26V, RI = 10K Ohms	(Note 10)	40		V/mV	4
		Vcc+ = 30V, Vcc- = GND, 5V ≤ Vo ≤ 20V, RI = 2K Ohms	(Note 10)	40		V/mV	4

**Note 6:** Guaranteed by Vio tests.

**Note 7:** Datalog reading in K=V/mV

**Note 8:** Guaranteed, not tested

**Note 9:** Calculated parameters

**Note 10:** Pre and post irradiation limits are identical to those listed under AC and DC electrical characteristics except as listed in the Post Radiation Limits Table. These parts may be dose rate sensitive in a space environment and demonstrate enhanced low dose rate effect. Radiation end point limits for the noted parameters are guaranteed only for the conditions as specified in MIL-STD-883, Method 1019

# Typical Performance Characteristics

**Input Voltage Range**

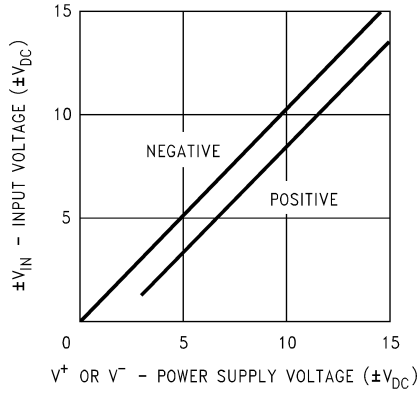

20108034

**Input Current**

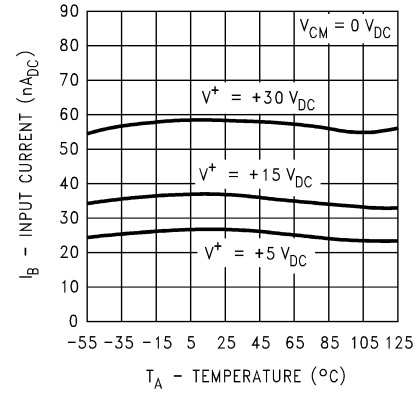

20108035

**Supply Current**

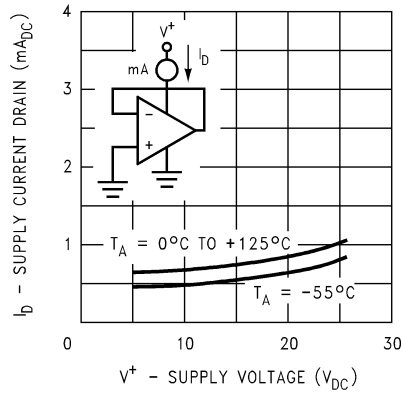

20108036

**Voltage Gain**

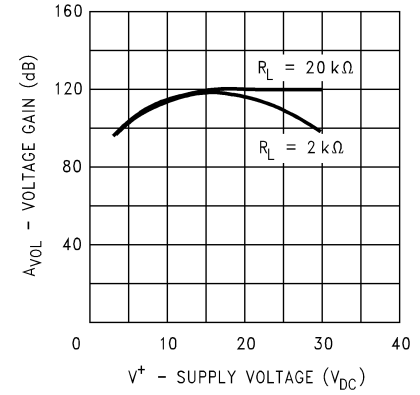

20108037

**Open Loop Frequency Response**

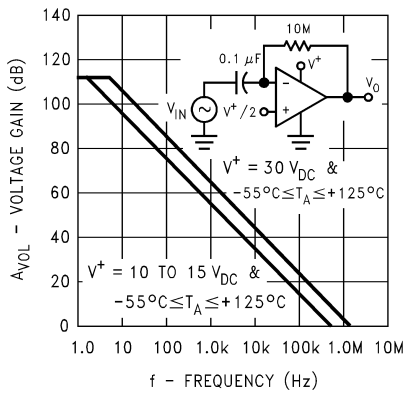

20108038

**Common Mode Rejection Ratio**

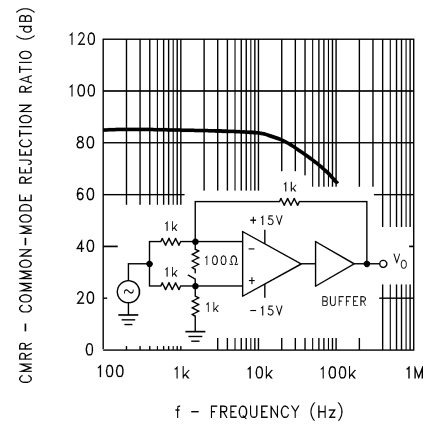

20108039

Typical Performance Characteristics (Continued)

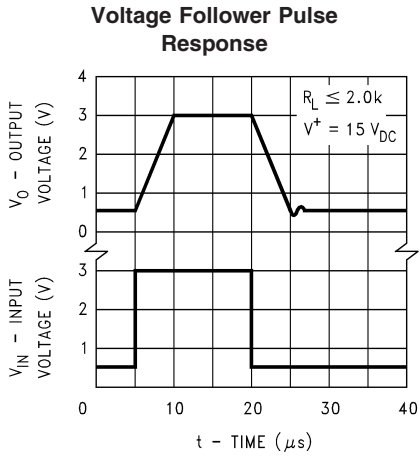

20108040

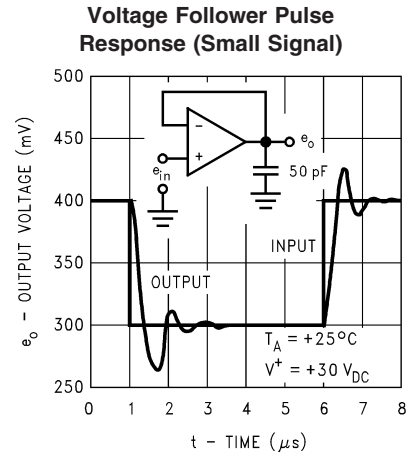

20108041

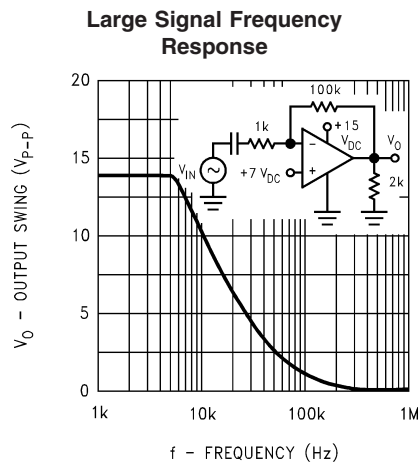

20108042

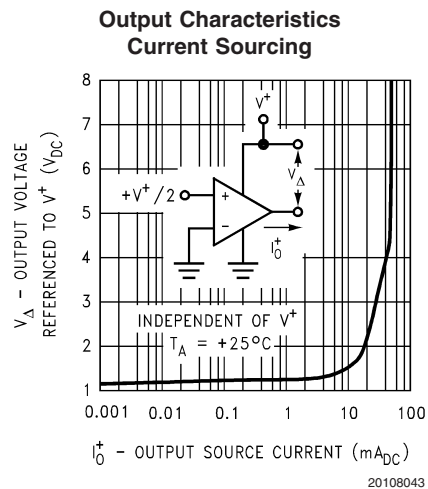

20108043

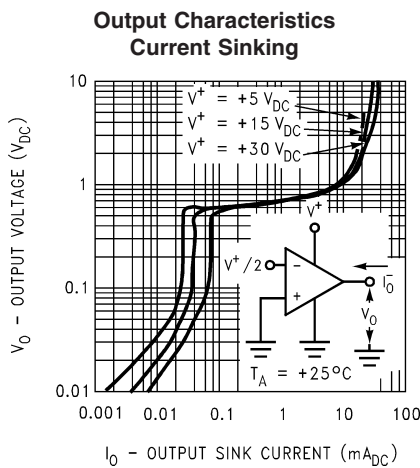

20108044

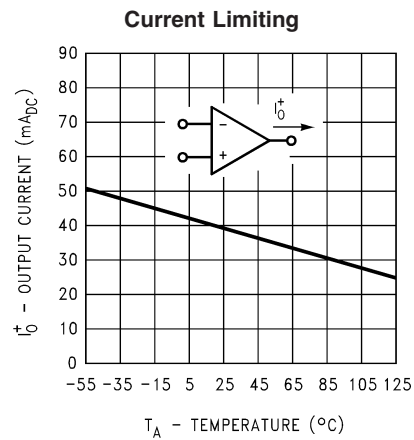

20108045

## Application Hints

The LM124 series are op amps which operate with only a single power supply voltage, have true-differential inputs, and remain in the linear mode with an input common-mode voltage of  $0 V_{DC}$ . These amplifiers operate over a wide range of power supply voltage with little change in performance characteristics. At  $25^{\circ}\text{C}$  amplifier operation is possible down to a minimum supply voltage of  $2.3 V_{DC}$ .

The pinouts of the package have been designed to simplify PC board layouts. Inverting inputs are adjacent to outputs for all of the amplifiers and the outputs have also been placed at the corners of the package (pins 1, 7, 8, and 14).

Precautions should be taken to insure that the power supply for the integrated circuit never becomes reversed in polarity or that the unit is not inadvertently installed backwards in a test socket as an unlimited current surge through the resulting forward diode within the IC could cause fusing of the internal conductors and result in a destroyed unit.

Large differential input voltages can be easily accommodated and, as input differential voltage protection diodes are not needed, no large input currents result from large differential input voltages. The differential input voltage may be larger than  $V^+$  without damaging the device. Protection should be provided to prevent the input voltages from going negative more than  $-0.3 V_{DC}$  (at  $25^{\circ}\text{C}$ ). An input clamp diode with a resistor to the IC input terminal can be used.

To reduce the power supply drain, the amplifiers have a class A output stage for small signal levels which converts to class B in a large signal mode. This allows the amplifiers to both source and sink large output currents. Therefore both NPN and PNP external current boost transistors can be used to extend the power capability of the basic amplifiers. The output voltage needs to raise approximately 1 diode drop above ground to bias the on-chip vertical PNP transistor for output current sinking applications.

For ac applications, where the load is capacitively coupled to the output of the amplifier, a resistor should be used, from the output of the amplifier to ground to increase the class A bias current and prevent crossover distortion.

Where the load is directly coupled, as in dc applications, there is no crossover distortion.

Capacitive loads which are applied directly to the output of the amplifier reduce the loop stability margin. Values of 50 pF can be accommodated using the worst-case non-inverting unity gain connection. Large closed loop gains or resistive isolation should be used if larger load capacitance must be driven by the amplifier.

The bias network of the LM124 establishes a drain current which is independent of the magnitude of the power supply voltage over the range of from  $3 V_{DC}$  to  $30 V_{DC}$ .

Output short circuits either to ground or to the positive power supply should be of short time duration. Units can be destroyed, not as a result of the short circuit current causing metal fusing, but rather due to the large increase in IC chip dissipation which will cause eventual failure due to excessive junction temperatures. Putting direct short-circuits on more than one amplifier at a time will increase the total IC power dissipation to destructive levels, if not properly protected with external dissipation limiting resistors in series with the output leads of the amplifiers. The larger value of output source current which is available at  $25^{\circ}\text{C}$  provides a larger output current capability at elevated temperatures (see typical performance characteristics) than a standard IC op amp.

The circuits presented in the section on typical applications emphasize operation on only a single power supply voltage. If complementary power supplies are available, all of the standard op amp circuits can be used. In general, introducing a pseudo-ground (a bias voltage reference of  $V^+/2$ ) will allow operation above and below this value in single power supply systems. Many application circuits are shown which take advantage of the wide input common-mode voltage range which includes ground. In most cases, input biasing is not required and input voltages which range to ground can easily be accommodated.

# Typical Single-Supply Applications

( $V^+ = 5.0 V_{DC}$ )

**Non-Inverting DC Gain (0V Input = 0V Output)**

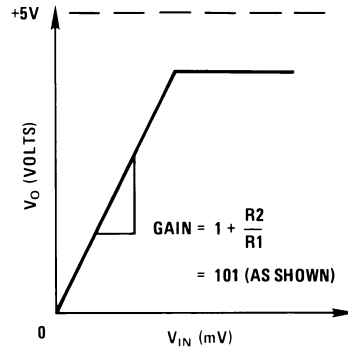
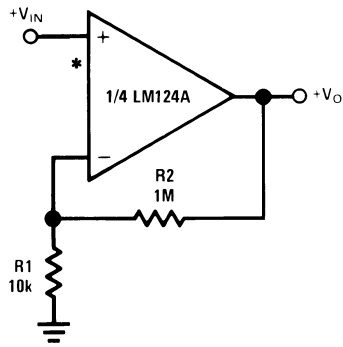

20108005

\*R not needed due to temperature independent  $I_{IN}$

**DC Summing Amplifier**  
( $V_{IN'S} \geq 0 V_{DC}$  and  $V_O \geq V_{DC}$ )

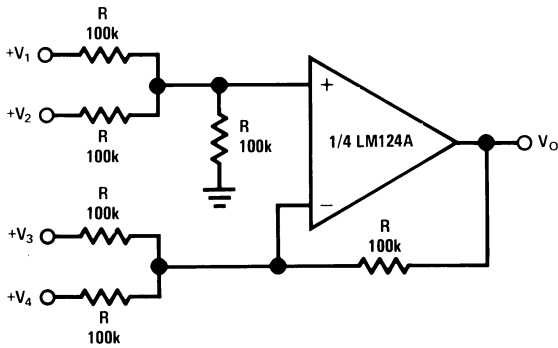

20108006

Where:  $V_O = V_1 + V_2 - V_3 - V_4$   
( $V_1 + V_2 \geq V_3 + V_4$ ) to keep  $V_O > 0 V_{DC}$

**Power Amplifier**

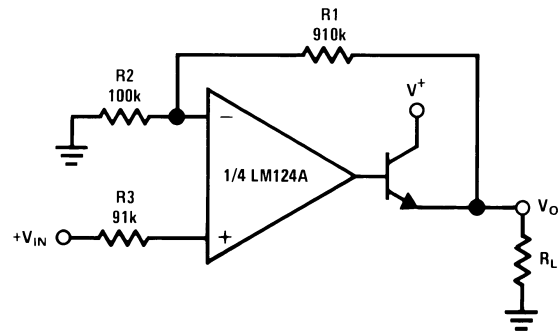

20108007

$V_O = 0 V_{DC}$  for  $V_{IN} = 0 V_{DC}$   
 $A_V = 10$

# Typical Single-Supply Applications (V<sup>+</sup> = 5.0 V<sub>DC</sub>) (Continued)

LED Driver

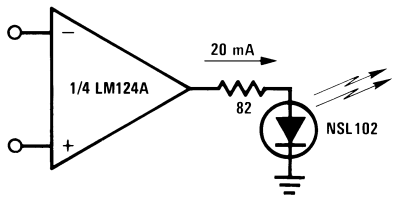

20108008

“BI-QUAD” RC Active Bandpass Filter

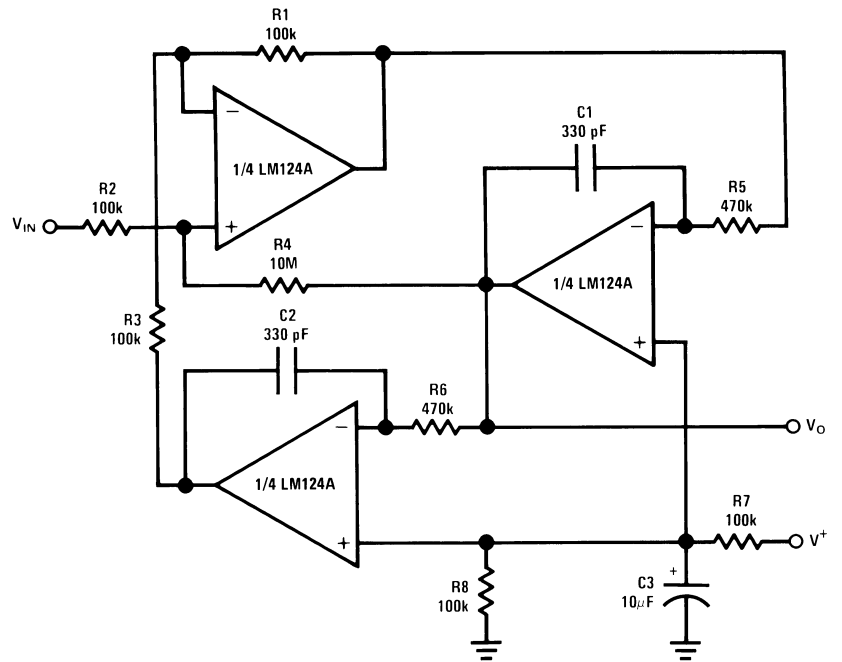

20108009

f<sub>o</sub> = 1 kHz  
 Q = 50  
 A<sub>v</sub> = 100 (40 dB)

Fixed Current Sources

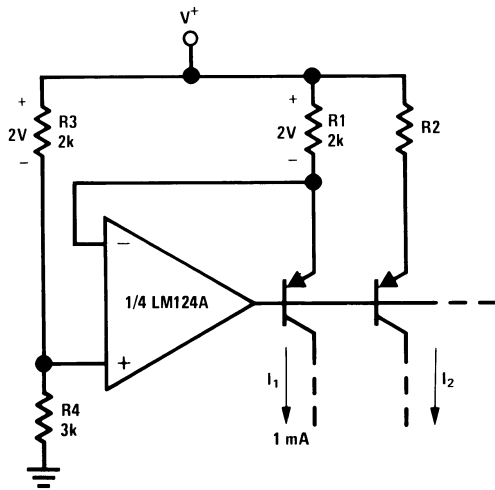

20108010

$$I_2 = \left( \frac{R_1}{R_2} \right) I_1$$

Lamp Driver

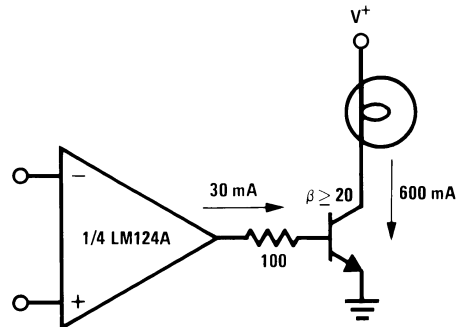

20108011



# Typical Single-Supply Applications

( $V^+ = 5.0 V_{DC}$ ) (Continued)

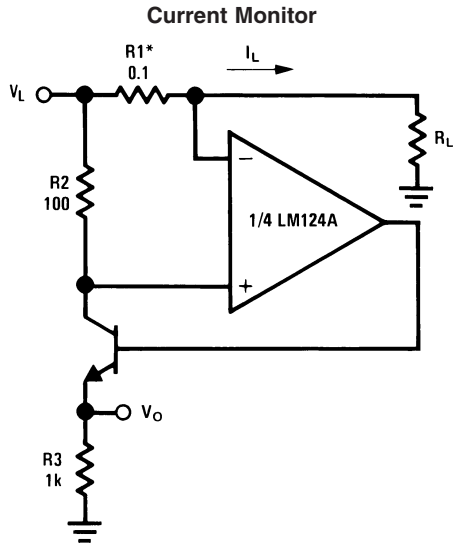

20108012

$$V_O = \frac{1V(I_L)}{1A}$$

$$V_L \leq V^+ - 2V$$

\*(Increase R1 for  $I_L$  small)

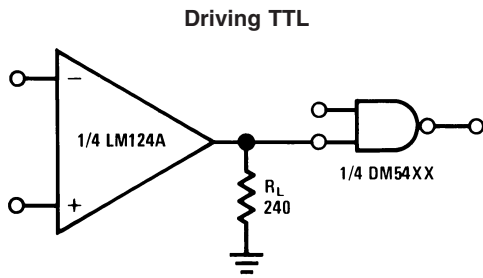

20108013

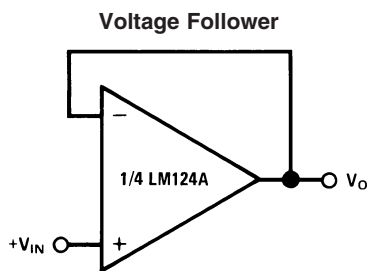

20108014

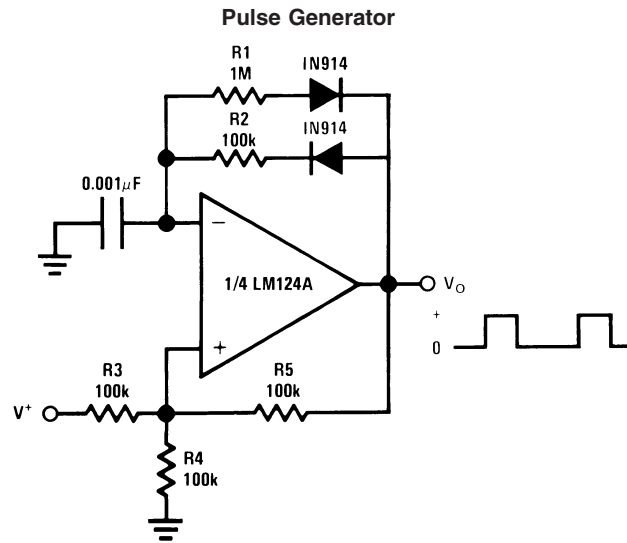

20108015

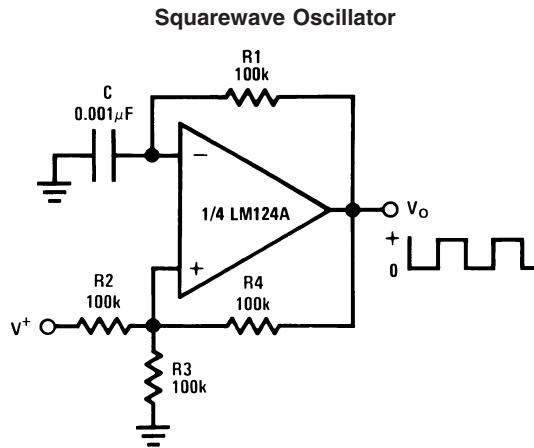

20108016

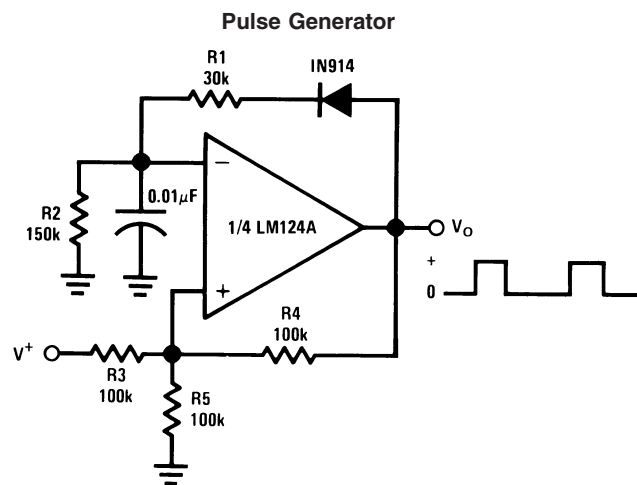

20108017

Typical Single-Supply Applications ( $V^+ = 5.0 V_{DC}$ ) (Continued)

High Compliance Current Sink

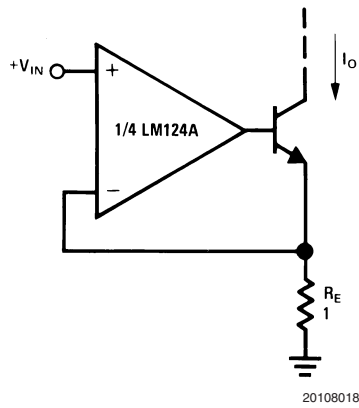

20108018

$I_o = 1 \text{ amp/volt } V_{IN}$   
(Increase  $R_E$  for  $I_o$  small)

Low Drift Peak Detector

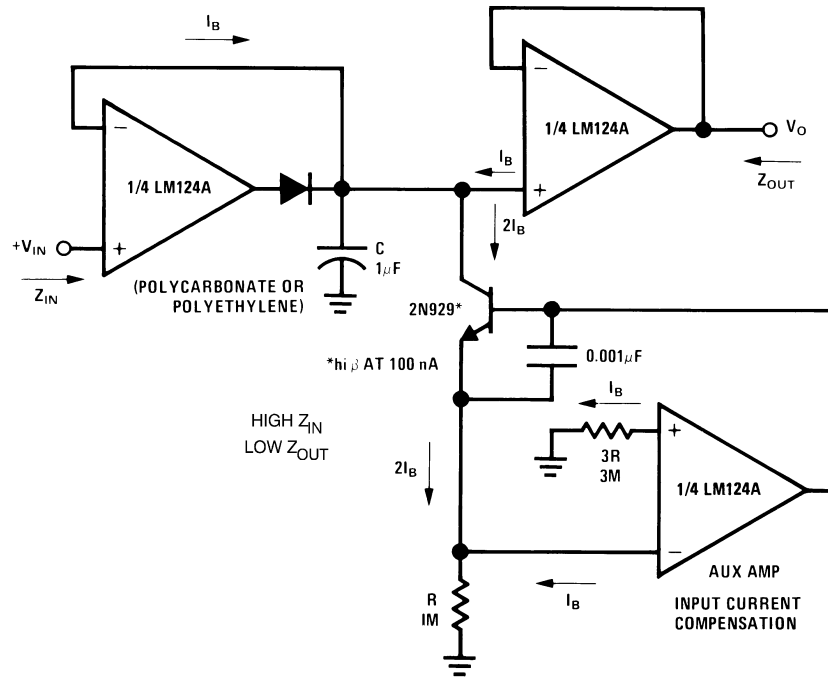

20108019

Typical Single-Supply Applications ( $V^+ = 5.0 V_{DC}$ ) (Continued)

Comparator with Hysteresis

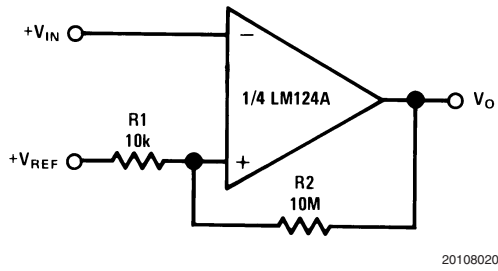

20108020

Ground Referencing a Differential Input Signal

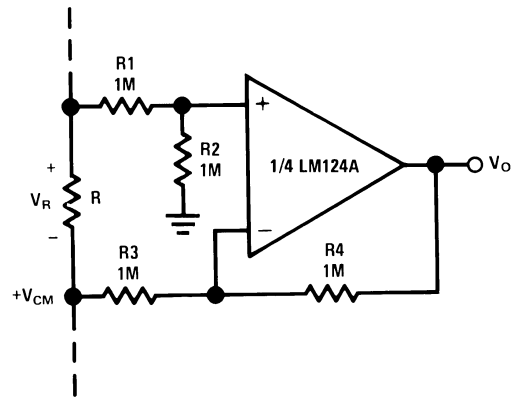

$V_O = V_R$

20108021

Voltage Controlled Oscillator Circuit

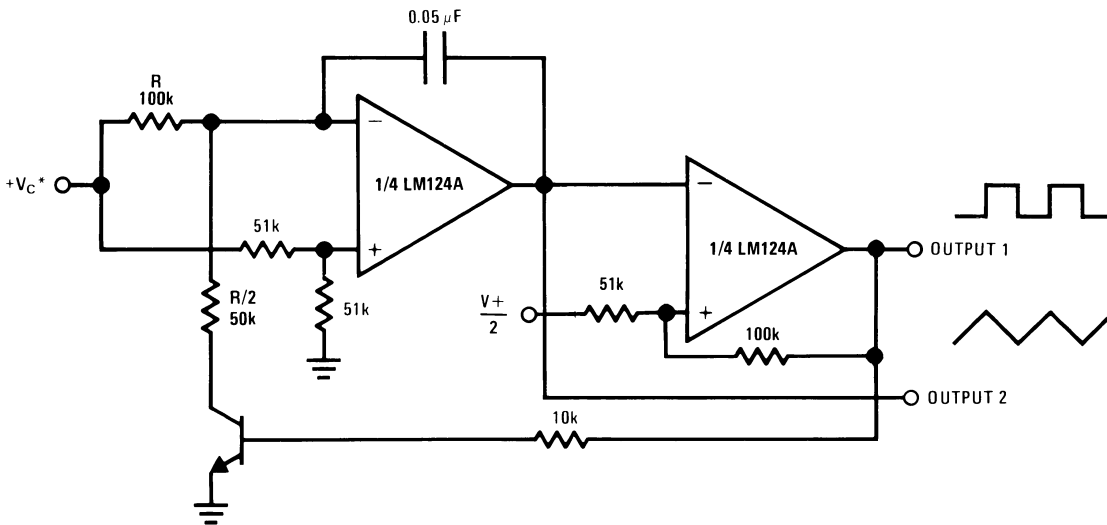

20108022

\*Wide control voltage range:  $0 V_{DC} \leq V_C \leq 2 (V^+ - 1.5 V_{DC})$

Photo Voltaic-Cell Amplifier

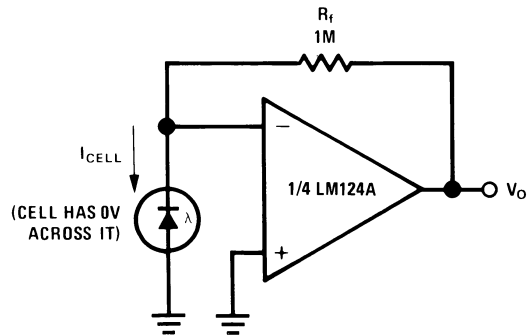

20108023

Typical Single-Supply Applications ( $V^+ = 5.0 V_{DC}$ ) (Continued)

AC Coupled Inverting Amplifier

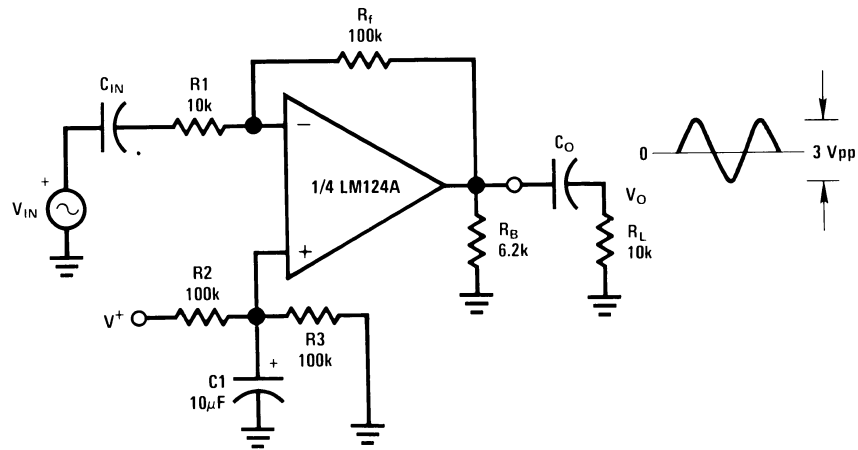

20108024

$$A_V = \frac{R_f}{R_1} \text{ (As shown, } A_V = 10 \text{)}$$

AC Coupled Non-Inverting Amplifier

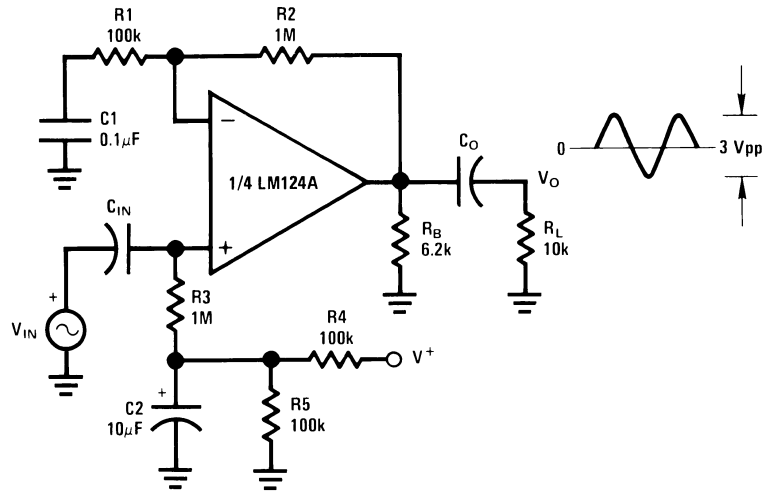

20108025

$$A_V = 1 + \frac{R_2}{R_1}$$

$$A_V = 11 \text{ (As shown)}$$

Typical Single-Supply Applications ( $V^+ = 5.0 V_{DC}$ ) (Continued)

DC Coupled Low-Pass RC Active Filter

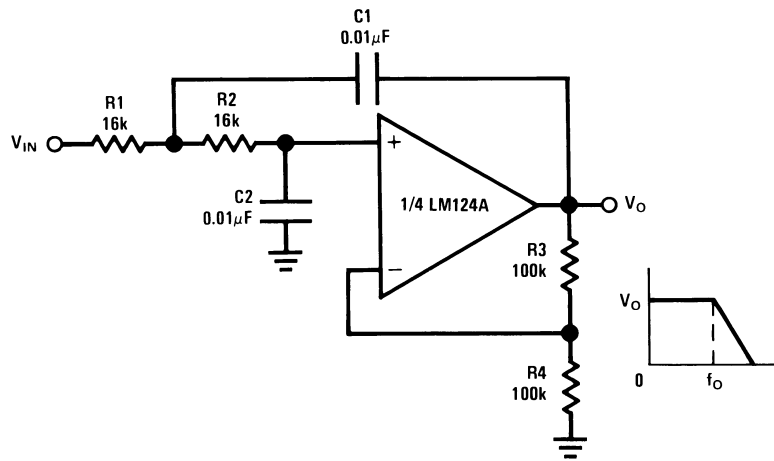

20108026

$f_o = 1 \text{ kHz}$   
 $Q = 1$   
 $A_V = 2$

High Input Z, DC Differential Amplifier

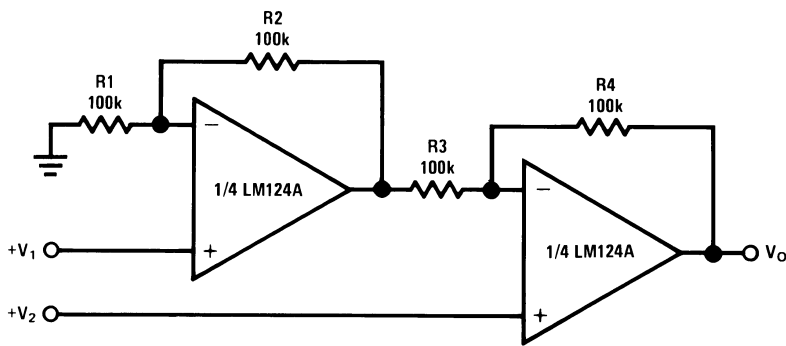

20108027

For  $\frac{R1}{R2} = \frac{R4}{R3}$  (CMRR depends on this resistor ratio match)

$V_O = 1 + \frac{R4}{R3} (V_2 - V_1)$

As shown:  $V_O = 2(V_2 - V_1)$

## Typical Single-Supply Applications ( $V^+ = 5.0 V_{DC}$ ) (Continued)

### High Input Z Adjustable-Gain DC Instrumentation Amplifier

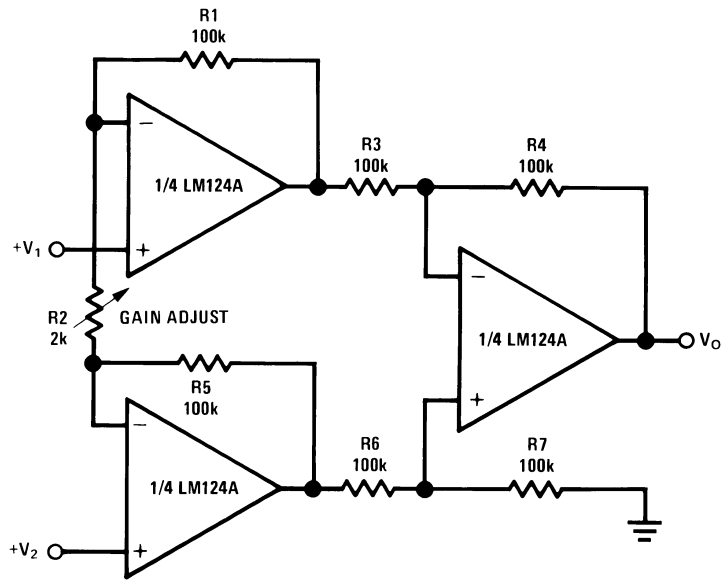

20108028

If  $R1 = R5$  &  $R3 = R4 = R6 = R7$  (CMRR depends on match)

$$V_O = 1 + \frac{2R1}{R2} (V_2 - V_1)$$

As shown  $V_O = 101 (V_2 - V_1)$

### Using Symmetrical Amplifiers to Reduce Input Current (General Concept)

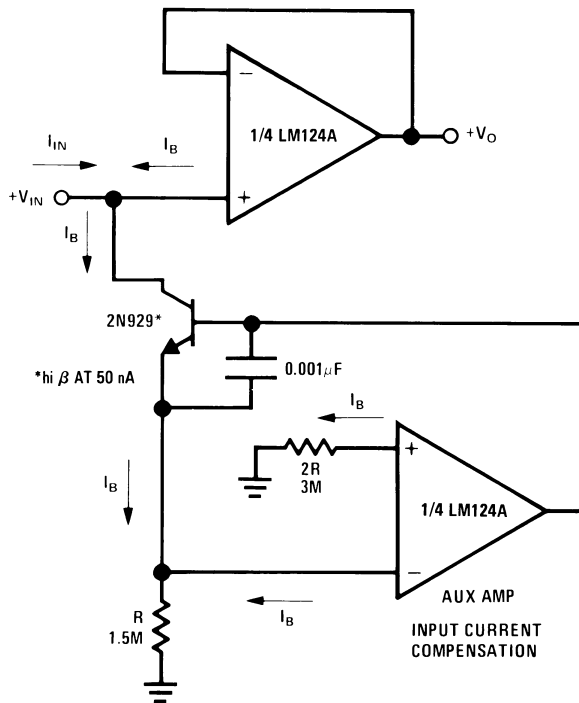

20108029

### Bridge Current Amplifier

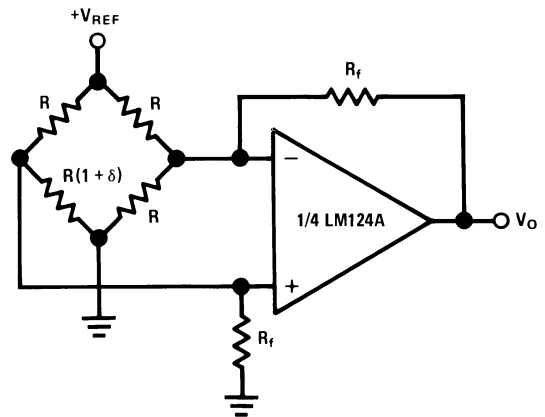

20108030

For  $\delta \ll 1$  and  $R_f \gg R$

$$V_O \approx V_{REF} \left( \frac{\delta}{2} \right) \frac{R_f}{R}$$

# Typical Single-Supply Applications $(V^+ = 5.0 V_{DC})$ (Continued)

## Bandpass Active Filter

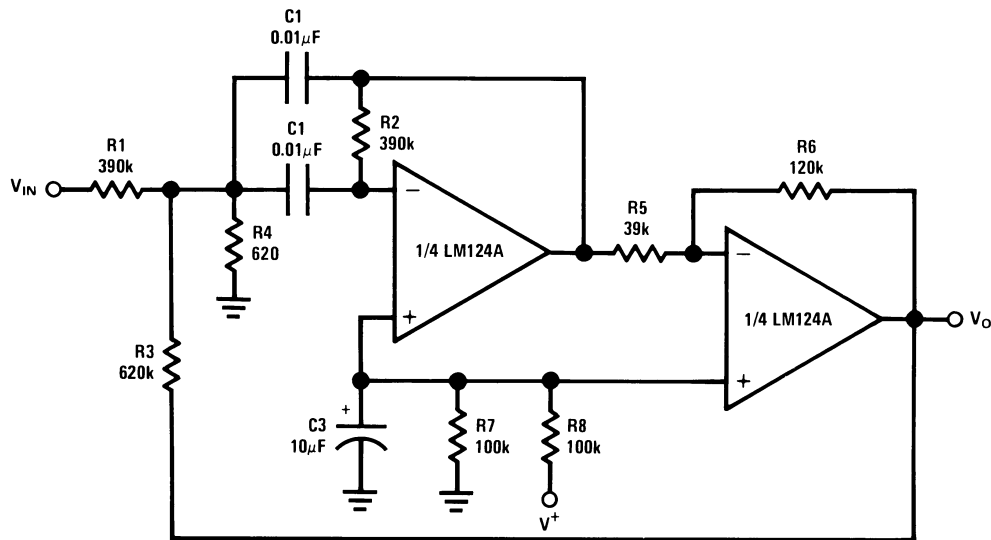

20108031

$f_0 = 1 \text{ kHz}$   
 $Q = 25$

## Revision History Section

Date Released	Revision	Section	Originator	Changes
9-2-04	A	New Release, Corporate format	R. Malone	3 MDS data sheets converted into one Corp. data sheet format. MNLM124-X, Rev. 1A2, MNLM124A-X, Rev. 1A3 and MRLM124A-X-RH, Rev. 5A0. MDS data sheets will be archived.
01/27/05	B	Connection Diagrams, Quality Conformance Inspection Section, and Physical Dimensions drawings	R. Malone	Added E package Connection Diagram. Changed verbiage under Quality Conformance Title, and Updated Revisions for the Marketing Drawings.



**Physical Dimensions** inches (millimeters) unless otherwise noted

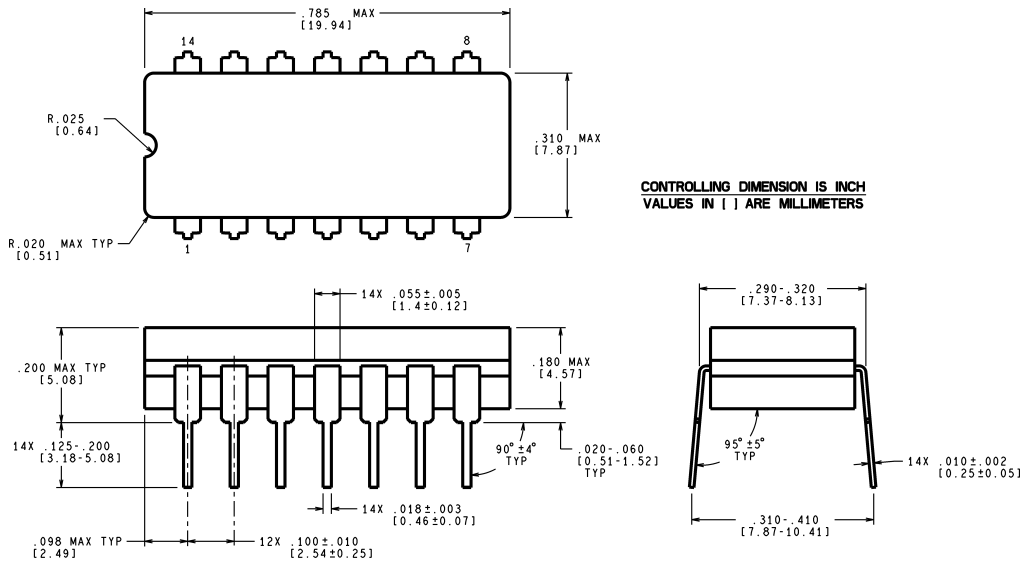

J14A (Rev J)

**SAMPLE TEXT Ceramic Dual-In-Line Package (J)  
NS Package Number J14A**

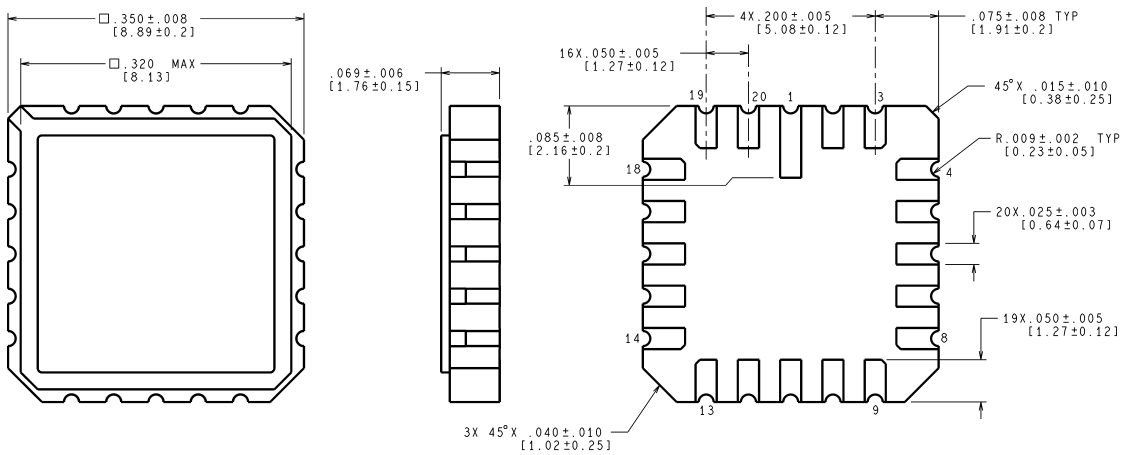

CONTROLLING DIMENSION IS INCH  
VALUES IN [ ] ARE MILLIMETERS

E20A (Rev F)

**SAMPLE TEXT 20 Pin Leadless Chip Carrier, Type C (E)  
NS Package Number E20A**

**Physical Dimensions** inches (millimeters) unless otherwise noted (Continued)

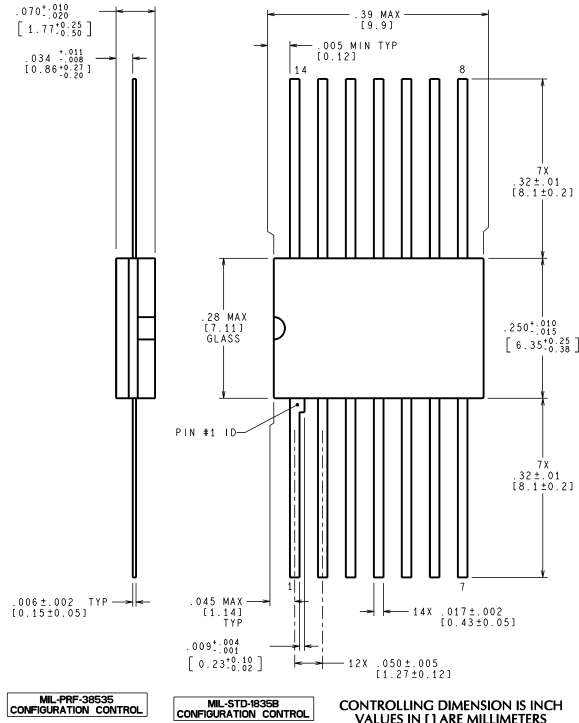

W14B (Rev P)

**SAMPLE TEXT Ceramic Flatpak Package  
NS Package Number W14B**

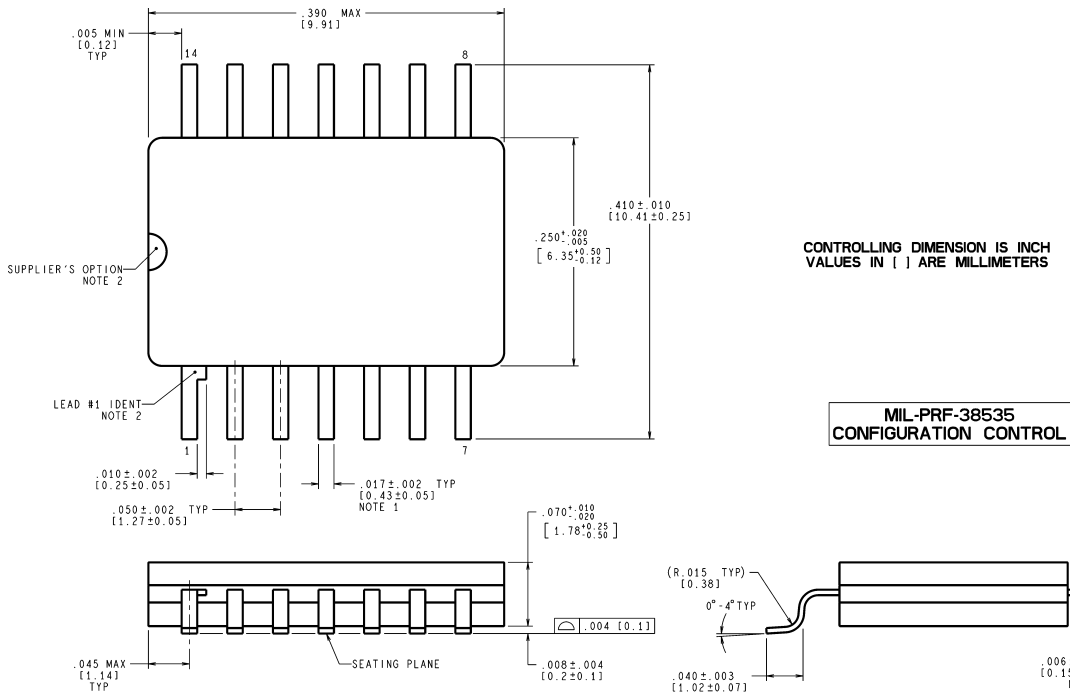

WG14A (Rev C)

**SAMPLE TEXT 14-Pin Ceramic Package (WG)  
NS Package Number WG14A**

## Notes

National does not assume any responsibility for use of any circuitry described, no circuit patent licenses are implied and National reserves the right at any time without notice to change said circuitry and specifications.

For the most current product information visit us at [www.national.com](http://www.national.com).

### LIFE SUPPORT POLICY

NATIONAL'S PRODUCTS ARE NOT AUTHORIZED FOR USE AS CRITICAL COMPONENTS IN LIFE SUPPORT DEVICES OR SYSTEMS WITHOUT THE EXPRESS WRITTEN APPROVAL OF THE PRESIDENT AND GENERAL COUNSEL OF NATIONAL SEMICONDUCTOR CORPORATION. As used herein:

1. Life support devices or systems are devices or systems which, (a) are intended for surgical implant into the body, or (b) support or sustain life, and whose failure to perform when properly used in accordance with instructions for use provided in the labeling, can be reasonably expected to result in a significant injury to the user.
2. A critical component is any component of a life support device or system whose failure to perform can be reasonably expected to cause the failure of the life support device or system, or to affect its safety or effectiveness.

### BANNED SUBSTANCE COMPLIANCE

National Semiconductor certifies that the products and packing materials meet the provisions of the Customer Products Stewardship Specification (CSP-9-111C2) and the Banned Substances and Materials of Interest Specification (CSP-9-111S2) and contain no "Banned Substances" as defined in CSP-9-111S2.



**National Semiconductor**  
**Americas Customer**  
**Support Center**  
 Email: [new.feedback@nsc.com](mailto:new.feedback@nsc.com)  
 Tel: 1-800-272-9959

[www.national.com](http://www.national.com)

**National Semiconductor**  
**Europe Customer Support Center**  
 Fax: +49 (0) 180-530 85 86  
 Email: [europa.support@nsc.com](mailto:europa.support@nsc.com)  
 Deutsch Tel: +49 (0) 69 9508 6208  
 English Tel: +44 (0) 870 24 0 2171  
 Français Tel: +33 (0) 1 41 91 8790

**National Semiconductor**  
**Asia Pacific Customer**  
**Support Center**  
 Email: [ap.support@nsc.com](mailto:ap.support@nsc.com)

**National Semiconductor**  
**Japan Customer Support Center**  
 Fax: 81-3-5639-7507  
 Email: [jpn.feedback@nsc.com](mailto:jpn.feedback@nsc.com)  
 Tel: 81-3-5639-7560