

L4973V3.3 - L4973V5.1 - L4973D3.3 - L4973D5.1

uses an internal power D-MOS transistor (with a typical $R_{ds(on)}$ of 0.15ohm) to obtain very high efficiency and very fast switching times.

Switching frequency up to 300KHz are achievable (the maximum power dissipation of the packages must be observed).

A wide input voltage range between 8V to 55V and output voltages regulated from 3.3V to 40V cover the majority of the today applications.

Features of this new generation of DC-DC con-

verter includes pulse by pulse current limit, hiccup mode for output short circuit protection, voltage feed forward regulation, soft start, input/output synchronization, protection against feedback loop disconnection, inhibit for zero current consumption and thermal shutdown.

Packages available are in plastic dual in line, DIP-18 (12+3+3) for standard assembly, and SO20 (12+4+4) for SMD assembly.

PIN CONNECTIONS (Top view)

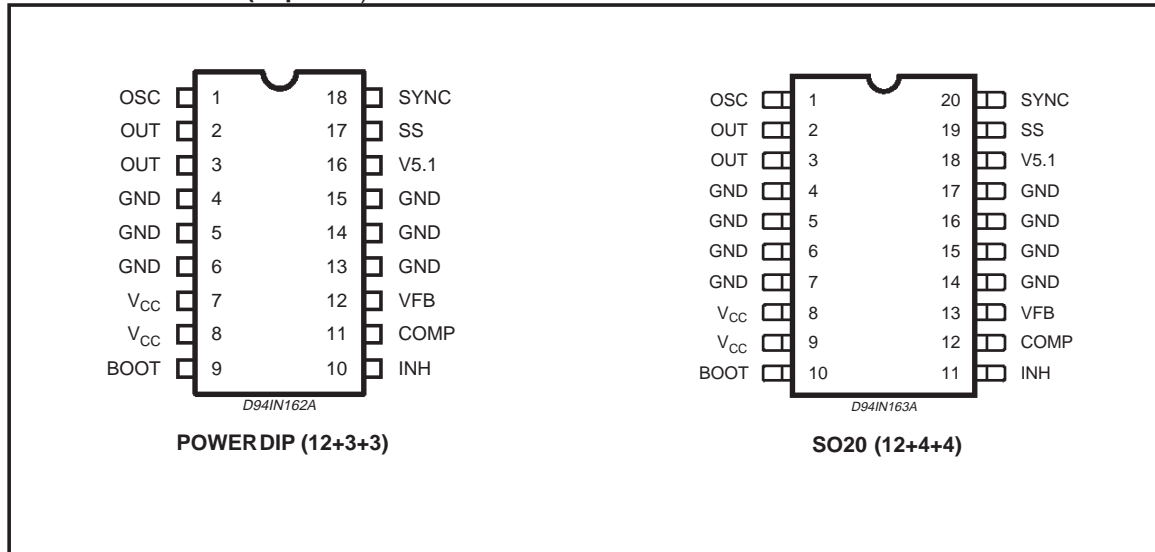

BLOCK DIAGRAM

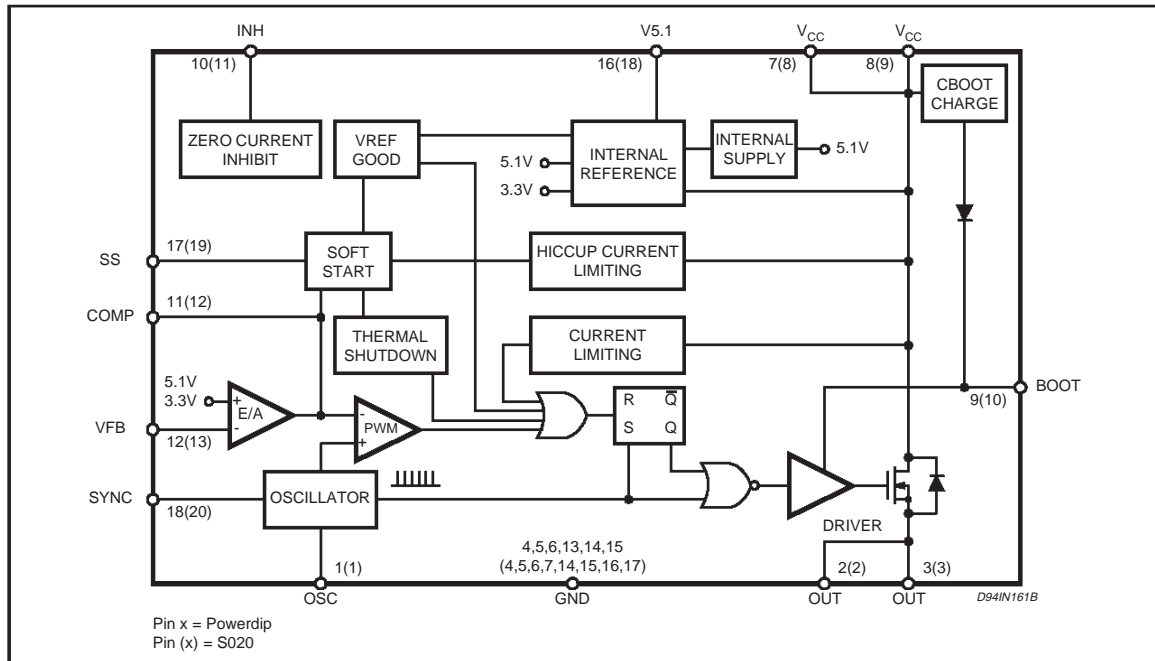

THERMAL DATA

Symbol	Parameter	Powerdip	SO20	Unit
$R_{th(j-pin)}$	Thermal Resistance Junction to pin	Max. 12	15	°C/W
$R_{th(j-amb)}$	Thermal Resistance to Ambient	Max. 60 (*)	80 (*)	°C/W

(*) Package mounted on board.

ABSOLUTE MAXIMUM RATINGS

Symbol		Parameter	Value	Unit	
DIP-18	SO-20				
V_7, V_8	V_9, V_8	Input voltage	58	V	
V_2, V_3	V_2, V_3	Output DC voltage	-1	V	
		Output peak voltage at $t = 0.1\mu s$ $f=200KHz$	-5	V	
I_2, I_3	I_2, I_3	Maximum output current	int. limit.		
V_9-V_8	$V_{10}-V_8$		14	V	
V_9	V_{10}	Bootstrap voltage	70	V	
V_{11}	V_{12}	Analogs input voltage ($V_{CC} = 24V$)	12	V	
V_{17}	V_{19}	Analogs input voltage ($V_{CC} = 24V$)	13	V	
V_{12}	V_{13}	($V_{CC} = 20V$)	6	V	
			-0.3	V	
V_{18}	V_{20}	($V_{CC} = 20V$)	5.5	V	
			-0.3	V	
V_{10}	V_{11}	Inhibit	V_{CC}	V	
			-0.3	V	
P_{tot}		Power dissipation a $T_{pins} \leq 90^\circ C$ ($T_{amb} = 70^\circ C$ no copper area) ($T_{amb} = 70^\circ C$ 4cm copper area on PCB)	DIP 12+3+3	5 1.3 2	W W W
		Power dissipation a $T_{pins} = 90^\circ C$	SO20	4	W
T_J, T_{STG}		Junction and storage temperature		-40 to 150	°C

PIN FUNCTIONS

Powerdip	SO20	NAME	DESCRIPTION
11	12	COMP	E/A output to be used for frequency compensation
10	11	INH	A logic signal (active high) disables the device (sleep mode operation). If not used it must be connected to GND; if floating the device is disabled.
9	10	BOOT	A capacitor connected between this pin and the output allows to drive the internal D-MOS.
18	20	SYNC	Input/Output synchronization.
7,8	8,9	V_{CC}	Unregulated DC input voltage
2,3	2,3	OUT	Stepdown regulator output.
12	13	VFB	Stepdown feedback input. Connecting the output directly to this pin results in an output voltage of 3.3V for the L4973V3.3 and 5.1V. An external resistive divider is required for higher output voltages. For output voltage less than 3.3V, see note ** and Figure 32.
16	18	V5.1	Reference voltage externally available.
4,5,6 13,14,15	4,5,6,7 14,15,16,17	GND	Signal ground
1	1	OSC	An external resistor connected between the unregulated input voltage and Pin 1 and a capacitor connected from Pin 1 to ground fixes the switching frequency. (Line feed forward is automatically obtained)

L4973V3.3 - L4973V5.1 - L4973D3.3 - L4973D5.1

ELECTRICAL CHARACTERISTICS (Refer to the test circuit, $V_{CC} = 24V$; $T_J = 25^{\circ}C$, $C_{osc} = 2.7nF$; $R_{osc} = 20K\Omega$; unless otherwise specified) ● = specifications referred to T_J from 0 to $125^{\circ}C$.

Symbol	Parameter	Test Conditions	Min.	Typ.	Max.	Unit	
DYNAMIC CHARACTERISTICS							
	Input Voltage Range (*)	$V_O = V_{REF}$ to 40V; $I_O = 3.5A$	●	8	55	V	
	Output Voltage L4973V5.1	$I_O = 1A$		5.05	5.1	5.15	V
		$I_O = 0.5A$ to 3.5A		5.00	5.1	5.20	V
		$V_{CC} = 8V$ to 55V	●	4.95	5.1	5.25	V
	Output Voltage L4973V3.3	$I_O = 1A$		3.326	3.36	3.393	V
		$I_O = 0.5A$ to 3.5A		3.292	3.36	3.427	V
		$V_{CC} = 8V$ to 40V	●	3.26	3.36	3.46	V
	$R_{DS(on)}$	$V_{CC} = 10.5V$			0.15	0.22	Ω
		$I_O = 3.5A$	●			0.35	Ω
	Maximum Limiting Current	$V_{CC} = 8V$ to 55V	●	4	4.5	5.5	A
η	Efficiency	$V_O = 5.1V$; $I_O = 3.5A$			90		%
		$V_O = 3.3V$; $I_O = 3.5A$			85		%
	Switching Frequency		●	90	100	110	KHz
	Supply Voltage Ripple Rejection	$V_i = V_{CC} + 2V_{RMS}$ $V_O = V_{ref}$; $I_O = 1A$; $f_{ripple} = 100Hz$		60			dB
Δf_{sw}	Switching Frequency Stability vs, Supply Voltage	$V_{CC} = 8V$ to 55V			2	5	%
REFERENCE SECTION							
	Reference Voltage			5.025	5.1	5.175	V
		$I_{ref} = 0$ to 20mA; $V_{CC} = 8$ to 55V	●	4.950	5.1	5.250	V
	Line Regulation	$I_{ref} = 0mA$; $V_{CC} = 8$ to 55V			5	10	mV
	Load Regulation	$V_{ref} = 0$ to 5mA; $V_{CC} = 0$ to 20mA			2	10	mV
					6	25	mV
	Short Circuit Current			30	65	100	mA
SOFT START							
	Soft Start Charge Current			30	45	60	μA
	Soft Start Discharge Current			15	22	30	μA
INHIBIT							
	High Level Voltage		●	3.0			V
	Low Level Voltage		●			0.8	V
	Isource High Level	$V_{INH} = 3V$	●	10	16	50	μA
	Isource Low Level	$V_{INH} = 0.8V$	●	10	15	50	μA
DC CHARACTERISTICS							
	Total Operating Quiescent Current	Duty Cycle = 50%			4	6	mA
	Quiescent Current	Duty Cycle = 0			2.7	4	mA
	Total stand-by quiescent current	$V_{CC} = 24V$; $V_{INH} = 5V$			100	200	μA
		$V_{CC} = 55V$; $V_{INH} = 5V$			150	300	μA
ERROR AMPLIFIER							
	High Level Output Voltage			11.0			V
	Low Level Output Voltage					0.65	V
	Source Bias Current			1	2	3	μA
	Source Output Current			200	300	600	μA

ELECTRICAL CHARACTERISTICS (continued)

	Sink Output Current		200	300		μ A
	Supply Voltage Ripple Rejection	$V_{COMP} = V_{FB}$ $C_{REF} = 4.7\mu F$ 1-5mA load current	60	80		dB
	DC Open Loop Gain	$R_L = \infty$	50	60		dB
	Transconductance	$I_{comp} = -0.1$ to 0.1 mA; $V_{comp} = 6$ V		2.5		mS

OSCILLATOR SECTION

	Ramp valley		0.78	0.85	0.92	V
	Ramp peak	$V_{CC} = 8$ V	1.9	2.1	2.3	V
		$V_{CC} = 55$ V	9	9.6	10.2	V
	Maximum Duty Cycle		95	97		%
	Maximum Frequency	Duty Cycle = 0%; $R_{OSC} = 13$ K Ω ; $C_{OSC} = 820$ pF;			500	KHz

SYNC FUNCTION

	High Input Voltage	$V_{CC} = 8$ to 55 V	3.5			V
	Low Input Voltage	$V_{CC} = 8$ to 55 V			0.9	V
	Slave Sink Current		0.15	0.25	0.45	mA
	Master Output Amplitude	$I_{source} = 3$ mA	4	4.5		V
	Output Pulse Width	no load, $V_{sync} = 4.5$ V	0.20	0.35		μ s

(*) Pulse testing with a low duty cycle.

(**) The maximum power dissipation of the package must be observed.

Figure 1. Evaluation Board Circuit

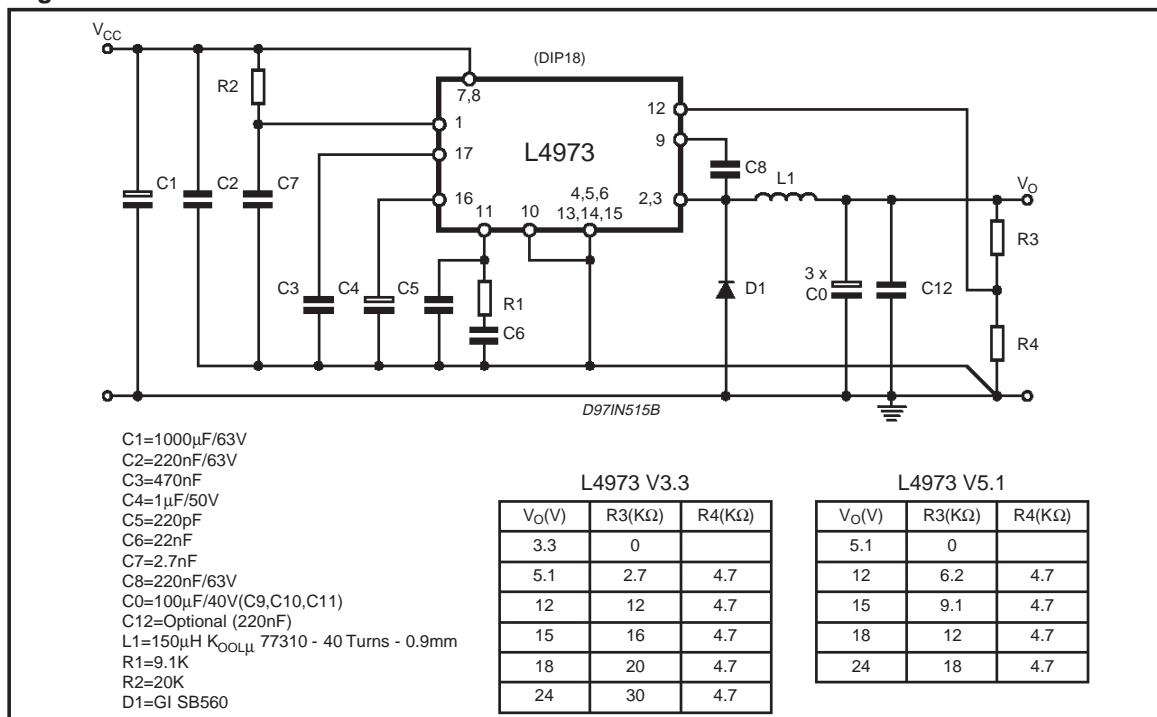

L4973V3.3 - L4973V5.1 - L4973D3.3 - L4973D5.1

Typical Performance (Using Evaluation Board) fsw = 100kHz

Output Voltage	Output Ripple	Efficiency	Line Regulator $I_o = 3.5A$ $V_{CC} = 8$ to $50V$	Load Regulator $V_{CC} = 35V$ $I_o = 1$ to $3.5A$
3.3V	20mV	81.5 (%)	3mV	6mV
5.1V	20mV	86.7 (%)	3mV	6mV
12V	30mV	93.5 (%)	3mV ($V_{CC} = 15$ to $50V$)	4mV

Figure 1a: Evaluation Board (Components Side)

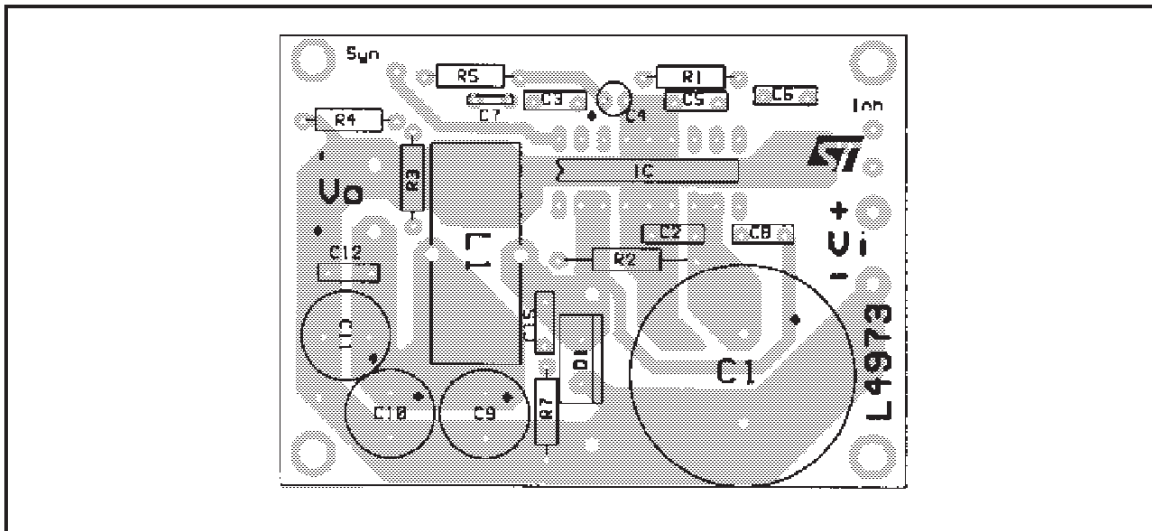

Figure 1b: Evaluation Board (Solder Side)

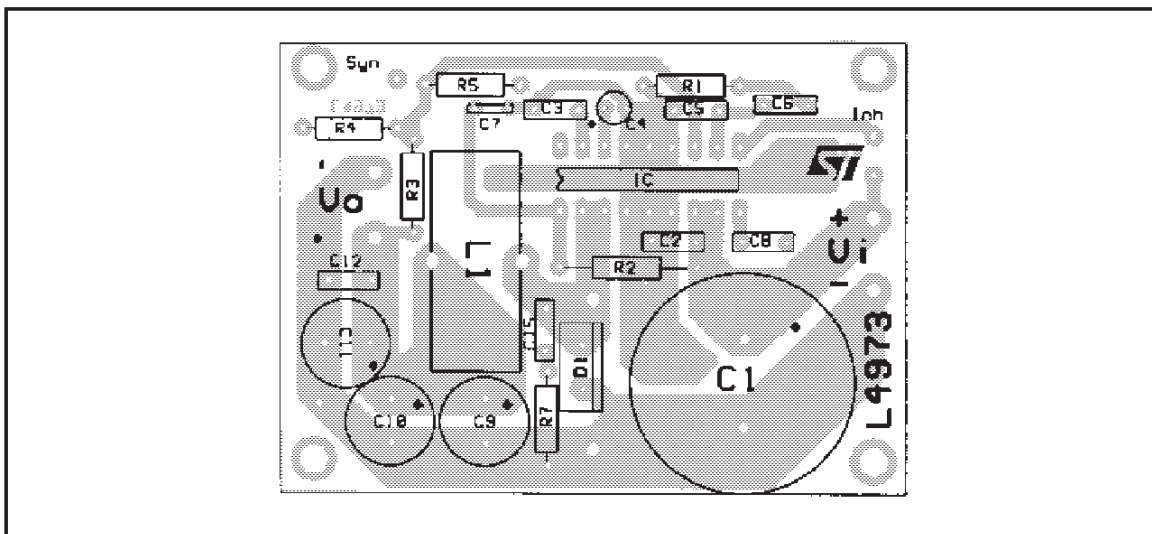

Figure 1c: Application Circuit (see fig. 1 part list)

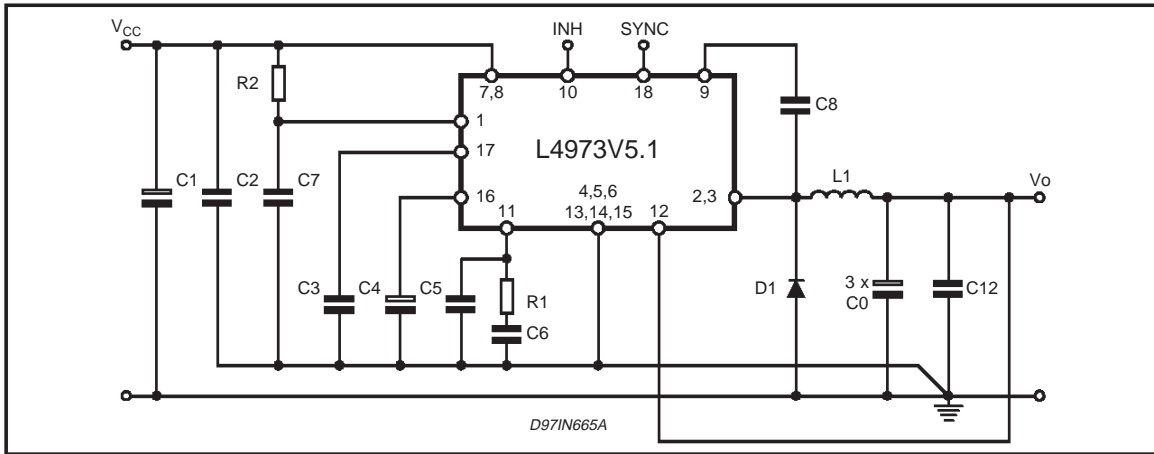

Figure 1d: Application Circuit (see fig. 1 part list)

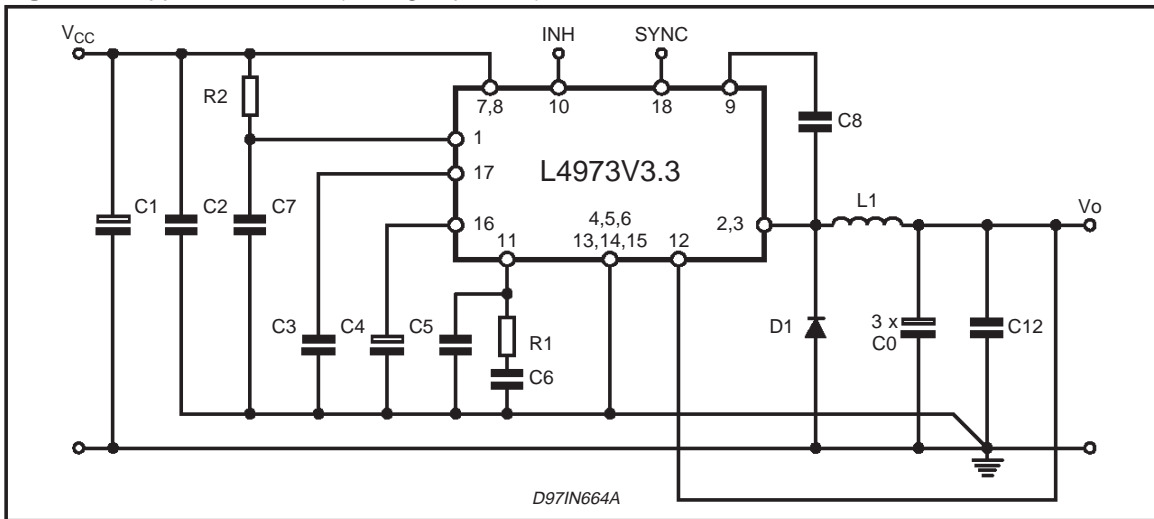

Figure 2: Quiescent Drain Current vs. Input Voltage (0% Duty Cycle)

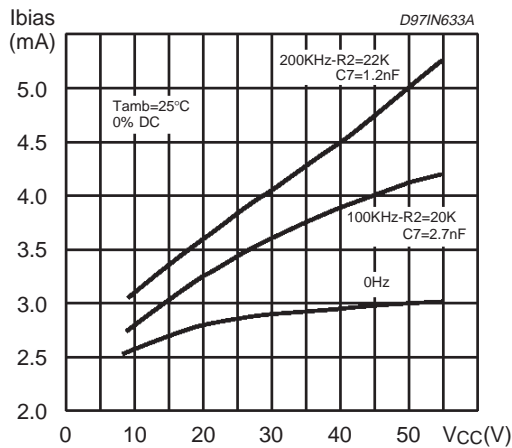

Figure 3: Quiescent Drain Current vs. Junction Temperature

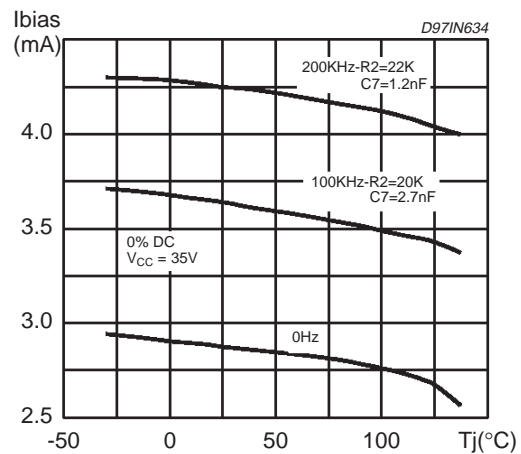

Figure 4: Stand by Drain Current vs. input Voltage

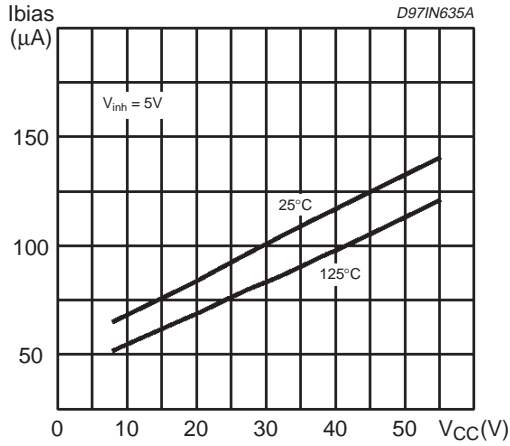

Figure 5: Reference Voltage vs. Junction Temperature (Pin 16)

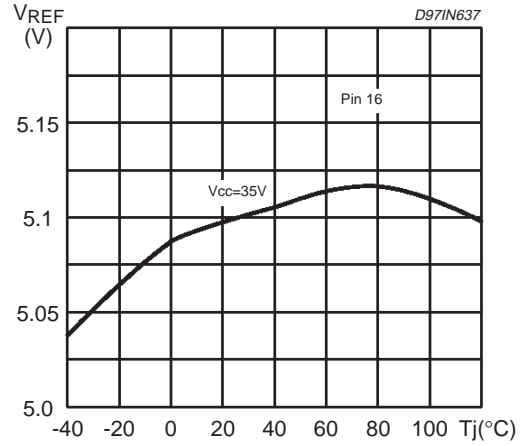

Figure 6: Reference Voltage vs. Input Voltage (Pin 16)

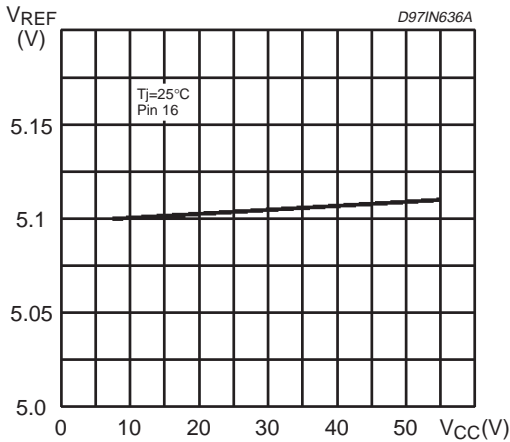

Figure 7: Reference Voltage vs. Reference Input Current

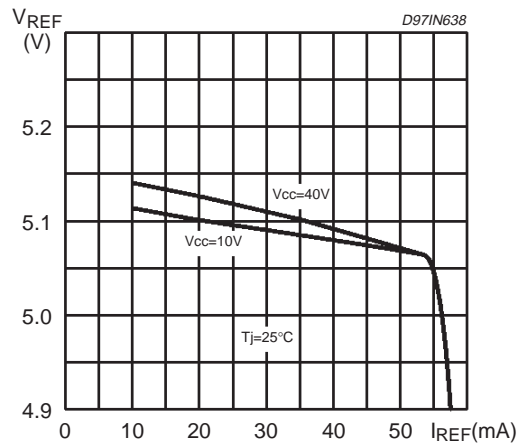

Figure 8: Inhibit Current vs. Inhibit Voltage (Pin 10)

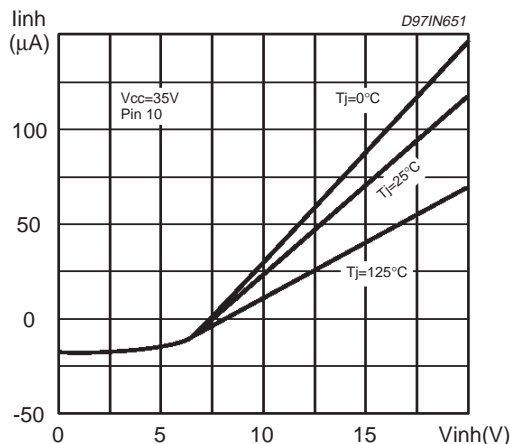

Figure 9: Line Regulation (see fig. 1)

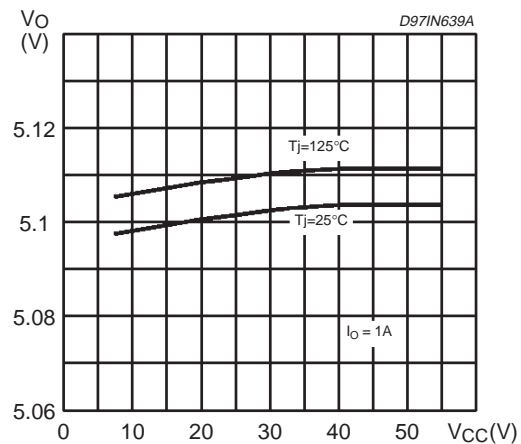

Figure 10: Load Regulation (see fig. 1c)

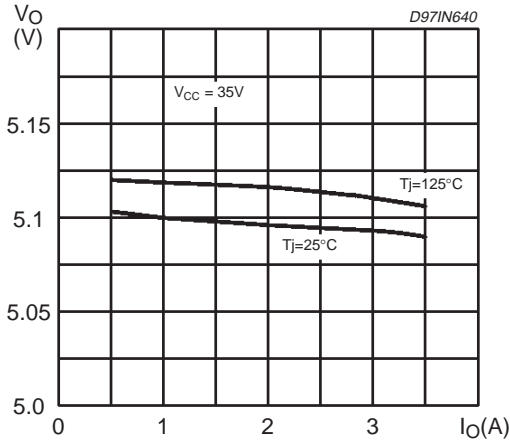

Figure 11: Line Regulation (see fig. 1d)

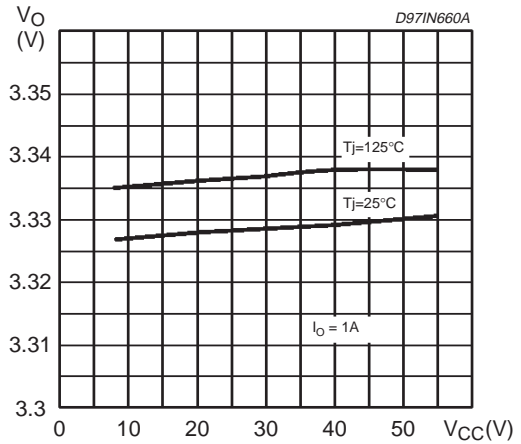

Figure 12: Load Regulation (see fig. 1d)

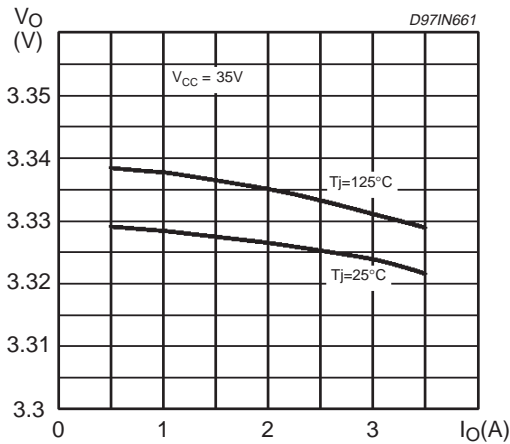

Figure 13: Switching Frequency vs. R2 and C7 (fig. 1)

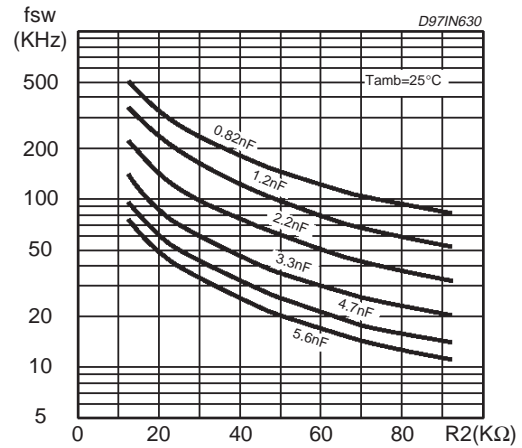

Figure 14: Switching Frequency vs. Input Voltage

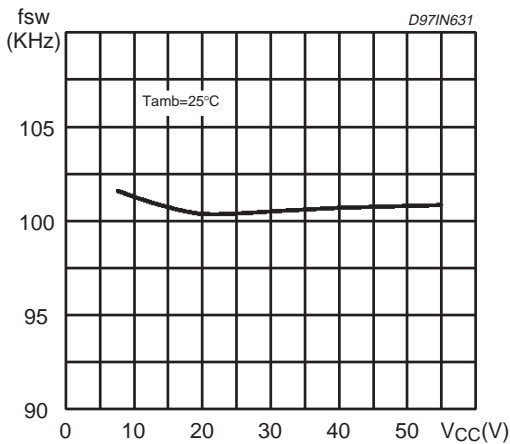

Figure 15: Switching Frequency vs. Junction temperature (see fig. 1)

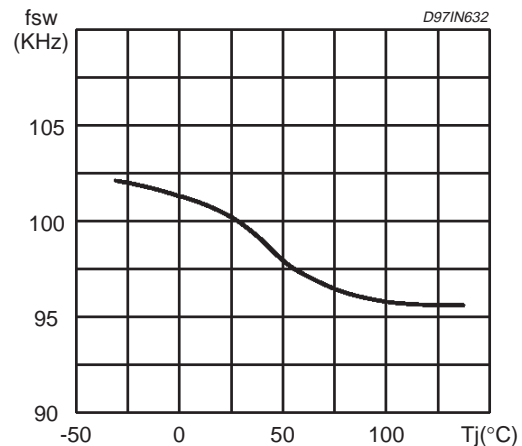

Figure 16: Dropout Voltage Between pin 7,8 and 2,3

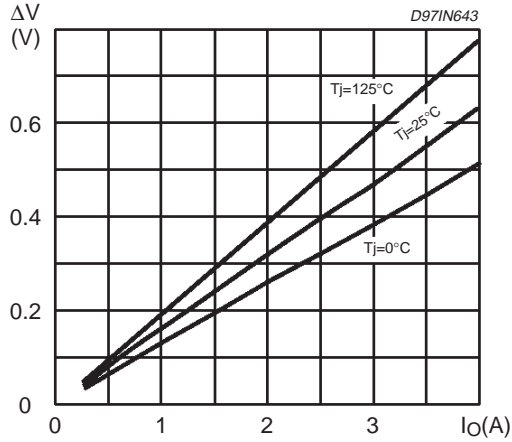

Figure 18: Efficiency vs. Output Voltage (Diode STPS745D)

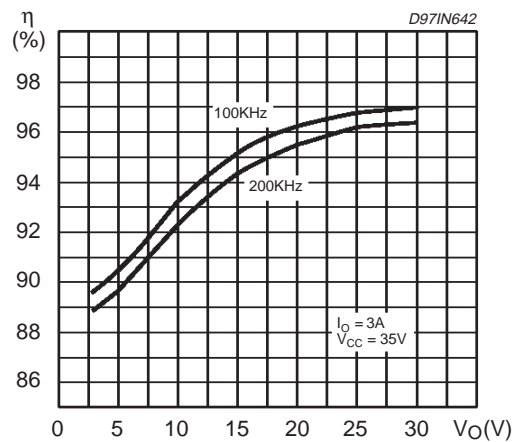

Figure 20: Efficiency vs. Output Current (see fig. 1c)

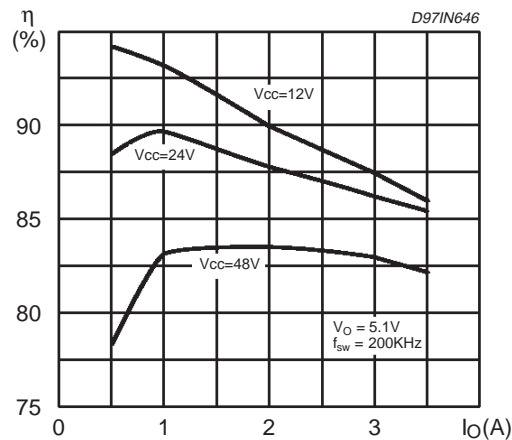

Figure 17: Efficiency vs. Output Voltage (see fig. 1)

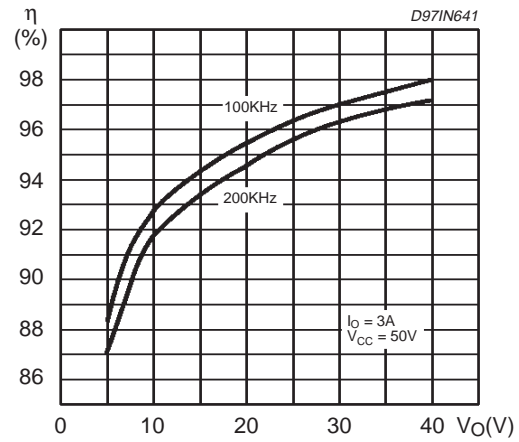

Figure 19: Efficiency vs. Output Current (see fig. 1c)

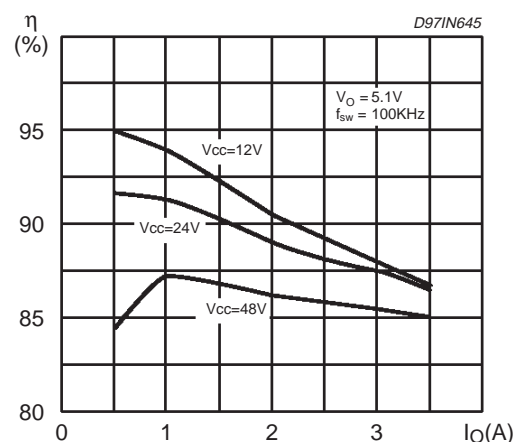

Figure 21: Efficiency vs. Output Current (see fig. 1d)

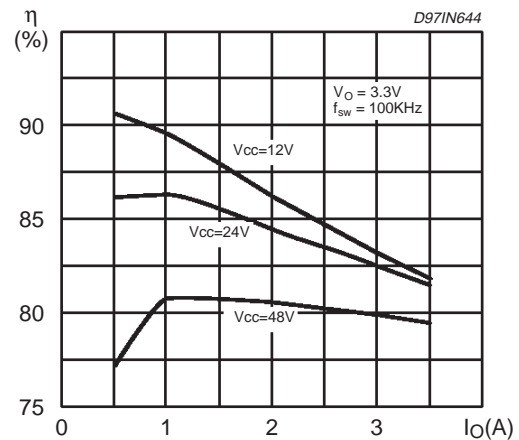

Figure 22: Efficiency vs. Output Current (see fig.1d)

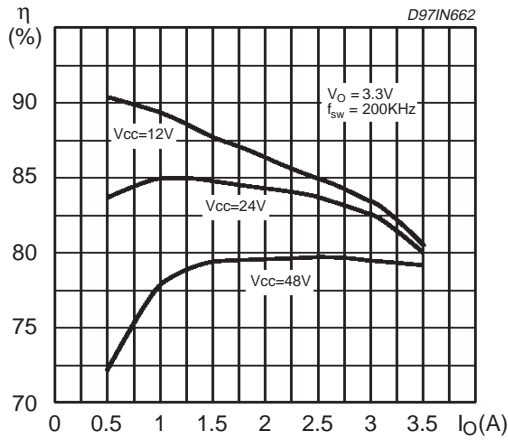

Figure 23: Power dissipation vs. Input Voltage (Device only) (see fig.1c)

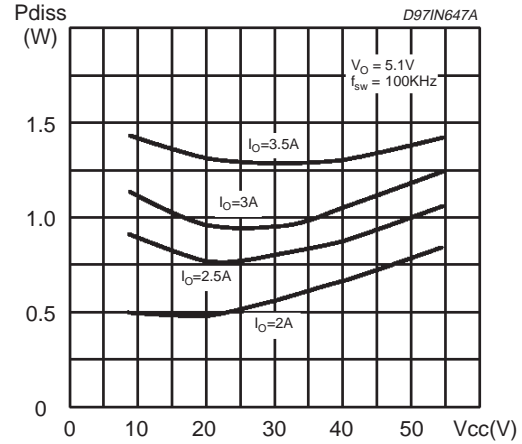

Figure 24: Power dissipation vs. Output Voltage (Device only)

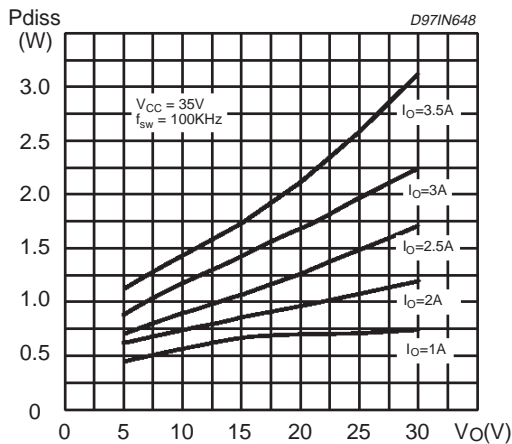

Figure 25: Pulse by Pulse Limiting Current vs. Junction Temperature

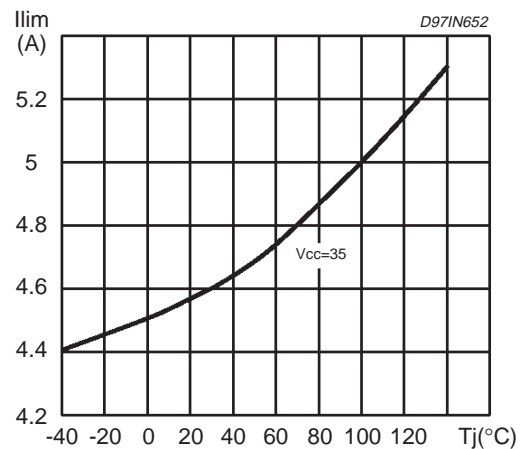

Figure 26: Load Transient

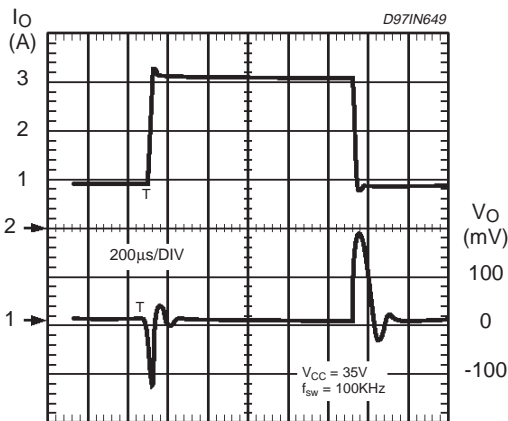
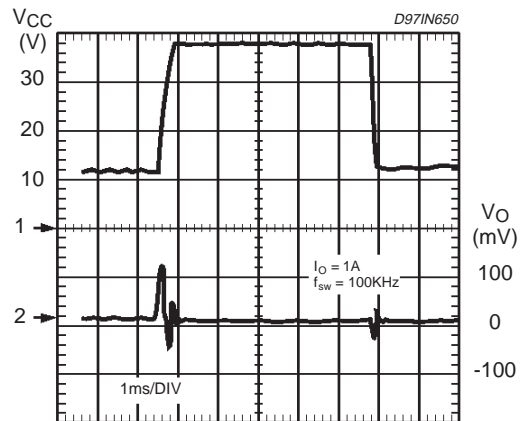

Figure 27: Line Transient



L4973V3.3 - L4973V5.1 - L4973D3.3 - L4973D5.1

Figure 28: Source Current Rise and Fall Time, pin 2, 3 (See fig1)

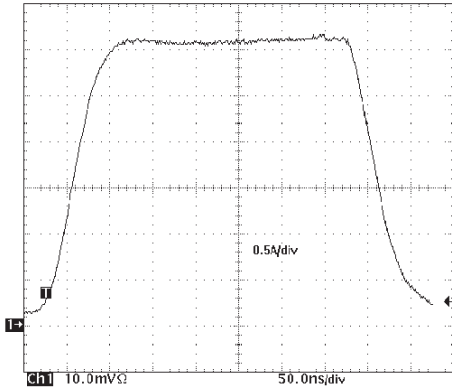

Figure 29: Soft Start Capacitor Selection vs. Inductor and Vcc max (ref. AN938)

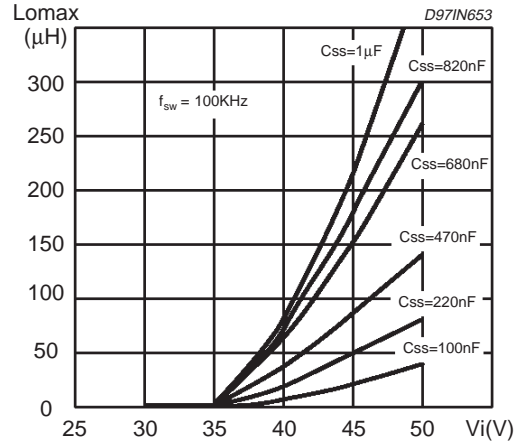

Figure 30: Soft Start Capacitor Selection vs. Inductor and Vcc max (ref. AN938)

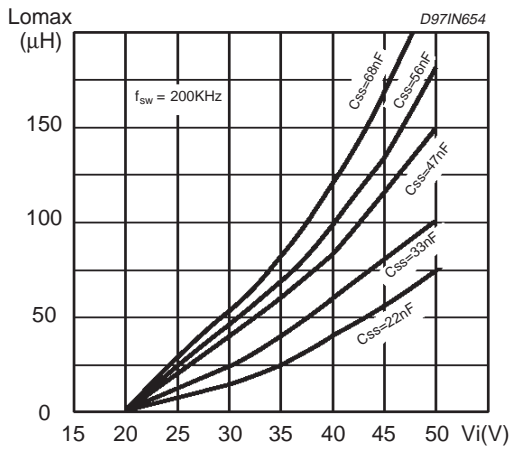

Figure 31: Open Loop Frequency and Phase of Error amplifier

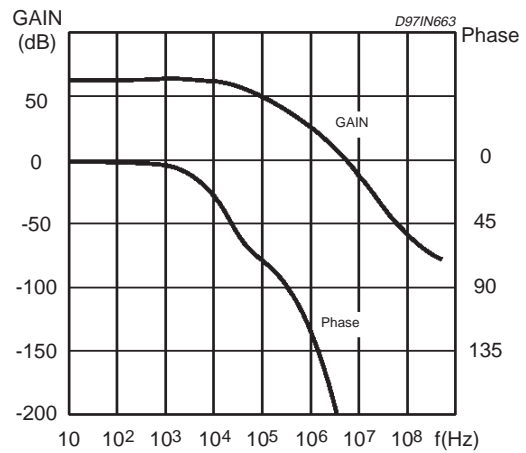

Figure 32: 3.5A at VO < 3.3V (see part list fig. 1)

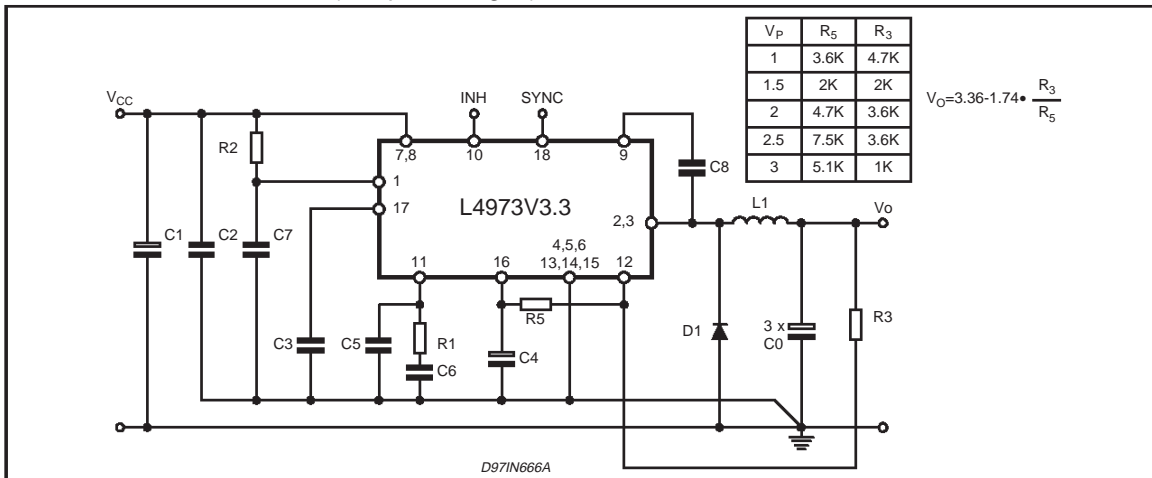

Figure 33: 12V to 3.3V High Performance Buck Converter ($f_{sw} = 200\text{kHz}$)

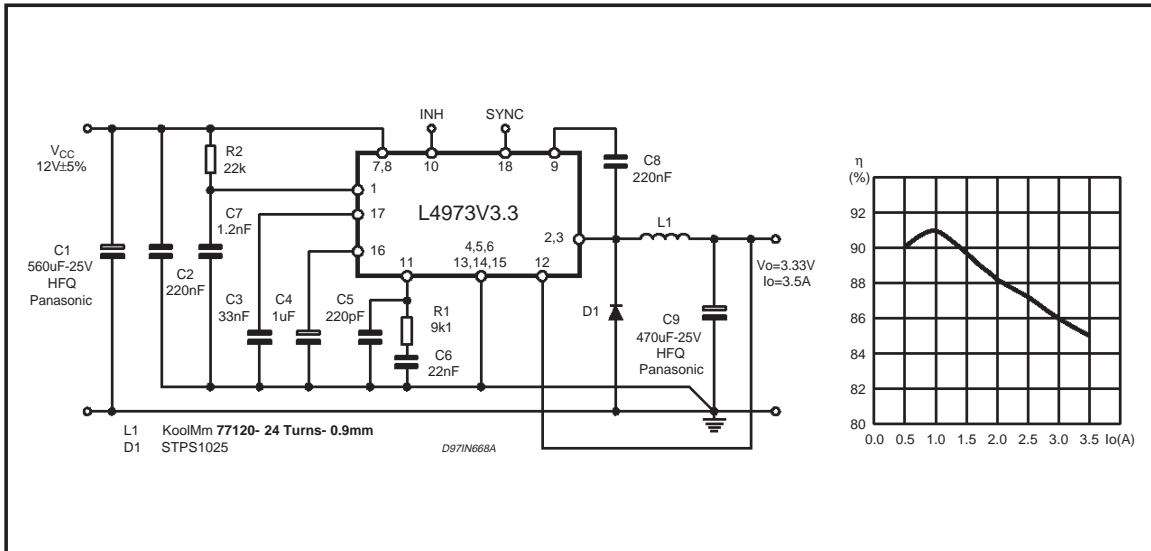

Figure 34: Synchronization Example

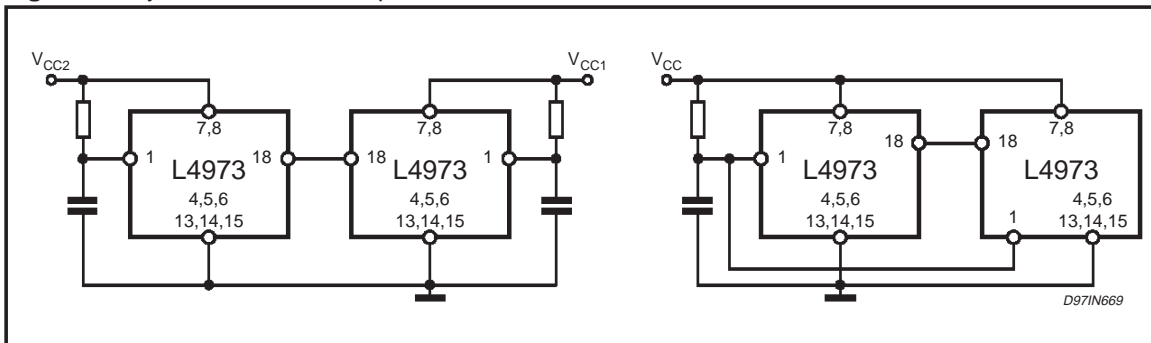
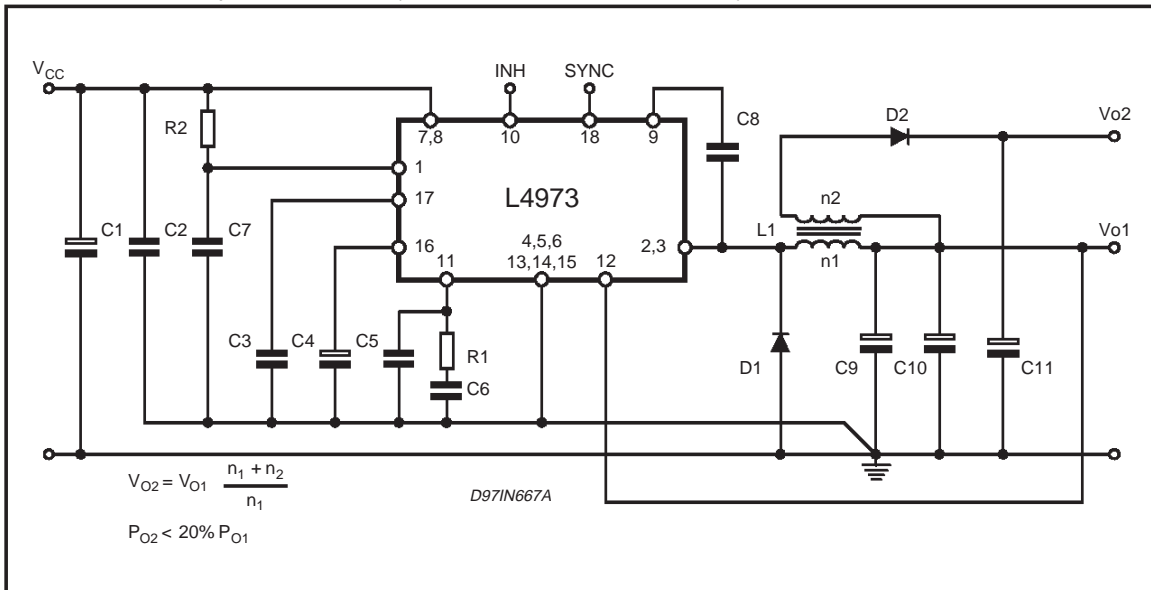

Figure 35: Multioutput not Isolated (Pin out referred to DIP12+3+3)



L4973V3.3 - L4973V5.1 - L4973D3.3 - L4973D5.1

DIM.	mm			inch		
	MIN.	TYP.	MAX.	MIN.	TYP.	MAX.
a1	0.51			0.020		
B	0.85		1.40	0.033		0.055
b		0.50			0.020	
b1	0.38		0.50	0.015		0.020
D			24.80			0.976
E		8.80			0.346	
e		2.54			0.100	
e3		20.32			0.800	
F			7.10			0.280
l			5.10			0.201
L		3.30			0.130	
Z			2.54			0.100

OUTLINE AND MECHANICAL DATA

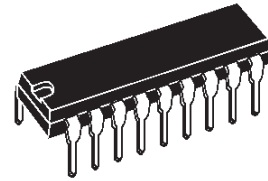

Powerdip 18

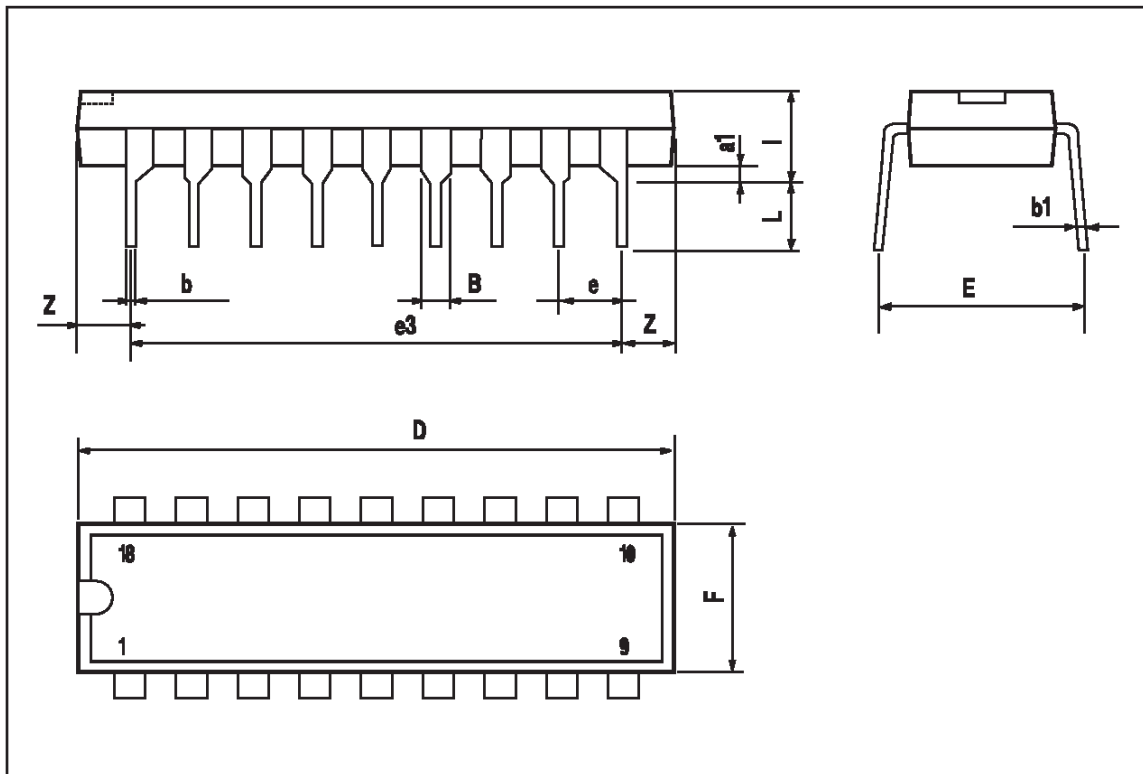

L4973V3 - L4973V5 - L4973D3 - L4973D5

DIM.	mm			inch		
	MIN.	TYP.	MAX.	MIN.	TYP.	MAX.
A	2.35		2.65	0.093		0.104
A1	0.1		0.3	0.004		0.012
B	0.33		0.51	0.013		0.020
C	0.23		0.32	0.009		0.013
D	12.6		13	0.496		0.512
E	7.4		7.6	0.291		0.299
e		1.27			0.050	
H	10		10.65	0.394		0.419
h	0.25		0.75	0.010		0.030
L	0.4		1.27	0.016		0.050
K	0° (min.)8° (max.)					

OUTLINE AND MECHANICAL DATA

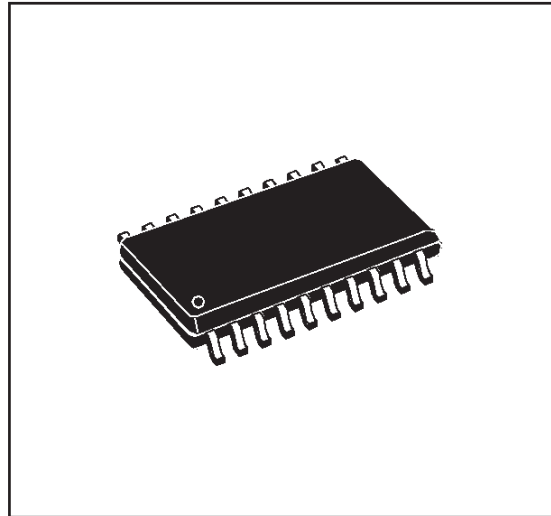

SO20

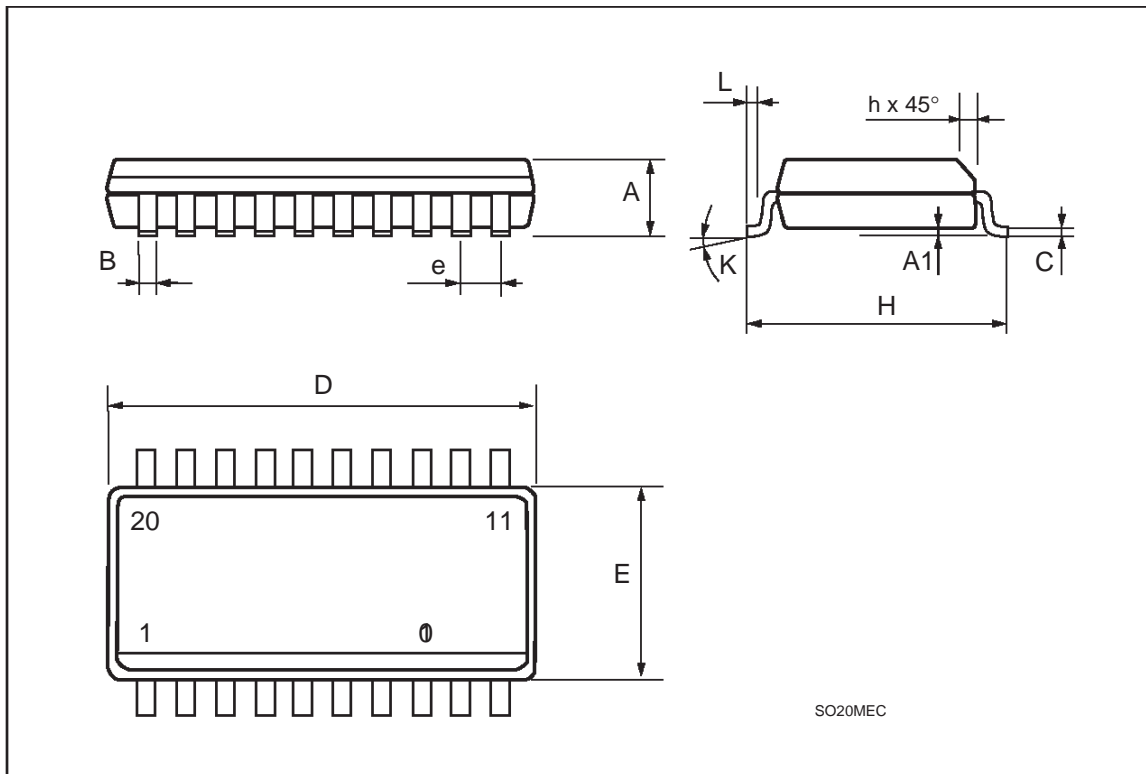

Information furnished is believed to be accurate and reliable. However, STMicroelectronics assumes no responsibility for the consequences of use of such information nor for any infringement of patents or other rights of third parties which may result from its use. No license is granted by implication or otherwise under any patent or patent rights of STMicroelectronics. Specification mentioned in this publication are subject to change without notice. This publication supersedes and replaces all information previously supplied. STMicroelectronics products are not authorized for use as critical components in life support devices or systems without express written approval of STMicroelectronics.

The ST logo is a registered trademark of STMicroelectronics

© 2000 STMicroelectronics – Printed in Italy – All Rights Reserved

STMicroelectronics GROUP OF COMPANIES

Australia - Brazil - China - Finland - France - Germany - Hong Kong - India - Italy - Japan - Malaysia - Malta - Morocco -
Singapore - Spain - Sweden - Switzerland - United Kingdom - U.S.A.

<http://www.st.com>