

# Portable PC/PCMCIA Power Controller

## GENERAL DESCRIPTION

The ML4880 Portable PC and PCMCIA Power Controller is a complete solution for DC/DC power conversion for portable computing systems with single or multiple PCMCIA slots.

The device provides two synchronous buck controllers to implement mixed voltage systems and a flyback controller for 12V  $V_{PP}$  generation for PCMCIA slots. The flyback architecture enables generation of high currents (150mA or more per slot) on the 12V bus for multiple slot PCMCIA applications.

Each regulator can be independently switched off to fully isolate the load from the power supply. The PFM architecture will automatically adjust switching frequency at light loads in order to maintain power conversion efficiencies in excess of 90% over a wide output power range.

## FEATURES

- Regulation to  $\pm 3\%$  maximum: provides 2% PCMCIA switch matrix margin
- Two synchronous buck controllers for 3.3/3V, 5V generation, and a flyback for high current, 12V generation from 5.5V to 18V input
- Regulator power conversion efficiencies  $> 90\%$
- Pulse frequency modulation for high efficiency operation
- Independent regulator shutdown for full load isolation
- Adjustable current limit
- Wide input voltage range (5.5V to 18V)

(\* Indicates Part is End Of Life as of July 1, 2000)

## BLOCK DIAGRAM

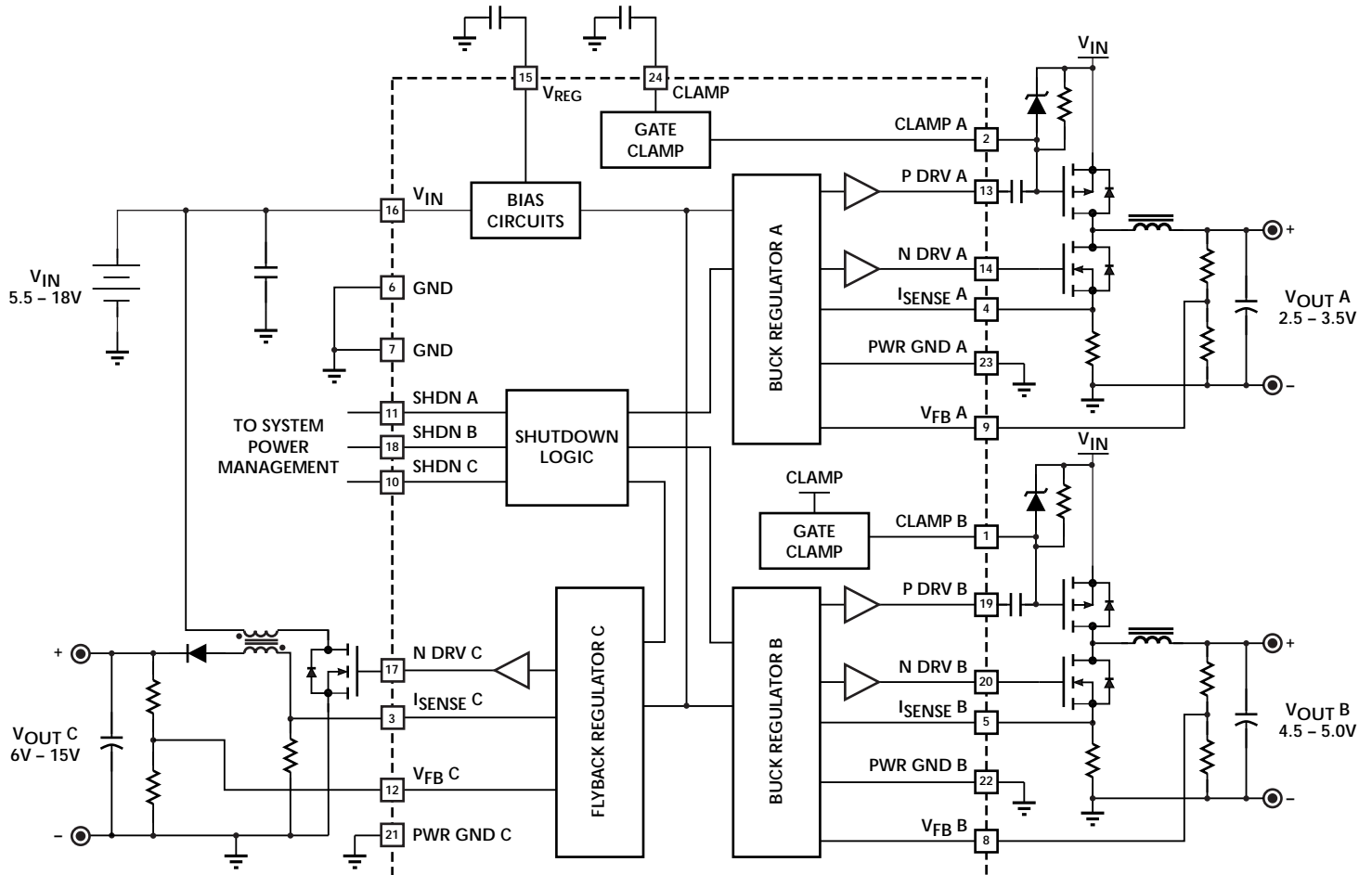

## PIN CONFIGURATION

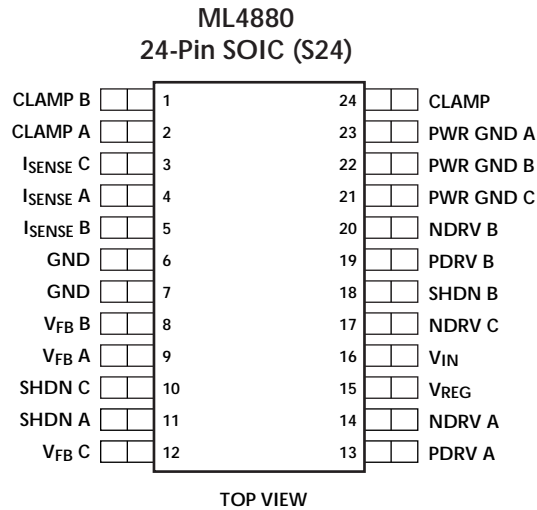

## PIN DESCRIPTION

PIN#	NAME	FUNCTION	PIN#	NAME	FUNCTION
1	CLAMP B	Gate clamp, regulator B	13	PDRV A	P-channel drive, regulator A
2	CLAMP A	Gate clamp, regulator A	14	NDRV A	N-channel drive, regulator A
3	I <sub>SENSE</sub> C	Current sense, regulator C	15	V <sub>REG</sub>	Linear regulator output
4	I <sub>SENSE</sub> A	Current sense, regulator A	16	V <sub>IN</sub>	Power supply input voltage
5	I <sub>SENSE</sub> B	Current sense, regulator B	17	NDRV C	N-channel drive, regulator C
6	GND	Ground	18	SHDN B	Shutdown input, regulator B
7	GND	Ground	19	PDRV B	P-channel drive, regulator B
8	V <sub>FB</sub> B	Feedback node, buck regulator B	20	NDRV B	N-channel drive, regulator B
9	V <sub>FB</sub> A	Feedback node, buck regulator A	21	PWR GND C	Power Ground, regulator C
10	SHDN C	Shutdown input, regulator C	22	PWR GND B	Power Ground, regulator B
11	SHDN A	Shutdown input, regulator A	23	PWR GND A	Power Ground, regulator A
12	V <sub>FB</sub> C	Feedback node, regulator C	24	CLAMP	Charge pump capacitor input

## ABSOLUTE MAXIMUM RATINGS

Absolute maximum ratings are those values beyond which the device could be permanently damaged. Absolute maximum ratings are stress ratings only and functional device operation is not implied.

$V_{IN}$ .....	20V
Peak Driver Output Current .....	2A
$V_{FB}$ Voltage .....	GND – 0.3V to 6V
$I_{SENSE}$ Voltage .....	$\pm 500\text{mV}$
All Other Analog Inputs .....	GND – 0.3V to $V_{IN} + 0.3\text{V}$
All Digital Inputs .....	GND – 0.3V to $V_{REG} + 0.3\text{V}$
Junction Temperature .....	150°C
Storage Temperature Range .....	–65°C to 150°C
Lead Temperature (Soldering, 10 sec) .....	150°C
Thermal Resistance ( $\theta_{JA}$ ) .....	80°C/W

## OPERATING CONDITIONS

$V_{IN}$ Range .....	5.5V to 18V
Temperature Range	
ML4880CS .....	0°C to 70°C
ML4880ES .....	–20°C to 70°C

## ELECTRICAL CHARACTERISTICS

Unless otherwise specified,  $V_{IN} = 14\text{V}$ ,  $C(V_{REG}) = 10\mu\text{F}$ ,  $T_A = \text{Operating Temperature Range (Note 1)}$

PARAMETER	CONDITIONS	MIN	TYP	MAX	UNITS
<b>Shutdown Inputs</b>					
Input Low Voltage				0.8	V
Input High Voltage		2.0			V
Input Bias Current		–1		1	$\mu\text{A}$
<b>Buck Regulator A</b>					
Duty Cycle Ratio	$V_{IN} = 5.5\text{V}$ , $I_{SENSE A} = V_{FB A} = 0\text{V}$	86		96	%
$V_{FB A}$ Threshold Voltage		1.21	1.25	1.29	V
$I_{SENSE A}$ Threshold Voltage		–140	–200	–250	mV
Transition Time	$C_L = 1000\text{pF}$ , 0 to $V_{REG}$		80	100	ns
<b>Buck Regulator B</b>					
Duty Cycle Ratio	$V_{IN} = 5.5\text{V}$ , $I_{SENSE B} = V_{FB B} = 0\text{V}$	92		98	%
$V_{FB B}$ Threshold Voltage		1.21	1.25	1.29	V
$I_{SENSE B}$ Threshold Voltage		–140	–200	–250	mV
Transition Time	$C_L = 1000\text{pF}$ , 0 to $V_{REG}$		80	100	ns
<b>Flyback Regulator C</b>					
Duty Cycle Ratio	$V_{IN} = 5.5\text{V}$ , $I_{SENSE C} = V_{FB C} = 0\text{V}$	86		94	%
	$V_{IN} = 18\text{V}$ , $I_{SENSE C} = V_{FB C} = 0\text{V}$	61		77	%
$V_{FB C}$ Threshold Voltage		1.21	1.25	1.29	V
$I_{SENSE C}$ Threshold Voltage		–140	–200	–250	mV
Transition Time	$C_L = 1000\text{pF}$ , 0 to $V_{REG}$		80	100	ns
<b>Supply</b>					
Linear Regulator Output Voltage	$7\text{V} \leq V_{IN} \leq 18\text{V}$	6.25		6.99	V
Linear Regulator Load Regulation	$I(V_{REG}) = 0$ to 10mA	6.10		6.99	V
$V_{IN}$ Current	SHDN A/B/C = 5V		300	350	$\mu\text{A}$
	SHDN A/B/C = 0V		350	400	$\mu\text{A}$

Note 1: Limits are guaranteed by 100% testing, sampling or correlation with worst case test conditions.

## FUNCTIONAL DESCRIPTION

The ML4880 converts a 5.5V to 18V input to three outputs via two synchronous buck controllers and a flyback controller. The two buck controllers utilize a unique current mode PFM control architecture that generate output voltages in the range of 2.5V to 3.5V (output A), and 4.5V to 5V (output B). The output current is set by external components, and can exceed 2A on each supply. The flyback controller also uses a current mode PFM control scheme and can be used to generate a 6V to 15V output. Again, the output current of the flyback is dependent on external components, and output currents of 500mA are obtainable. Even at light loads, the PFM architecture maintains high conversion efficiencies over a wide range of input voltages. If it is necessary to further extend battery life, the user can shutdown and fully disconnect each load from the input independently.

### BIAS CIRCUITS

The bias circuits are comprised of a linear regulator and a precision voltage reference. The linear regulator produces a supply voltage ( $V_{REG}$ ) used by the control circuits. The  $V_{REG}$  pin should be bypassed to GND with a 4.7 $\mu$ F to 10 $\mu$ F capacitor. The precision voltage reference is used by the feedback circuit of each controller to maintain an accurate output voltage.

### SHUTDOWN LOGIC

Each controller has a separate shutdown pin. By applying a logic high to the appropriate pin, the transconductance amplifier and current comparator of each controller (shown in Figures 1 and 3) can be disabled. This prevents switching from occurring and disconnects the load from the input. All other circuitry within the ML4880 remains active during shutdown.

### GATE CLAMP

The gate clamp circuit provides a method of preventing the buck regulator P-channel MOSFET switches from accidentally turning on when the input is suddenly switched to a higher voltage. This condition can occur during start-up or when an adapter voltage is applied. As shown in the block diagram, the P DRV drivers are capacitively coupled to the gates.

Assume that P DRV is in the OFF state, or at  $V_{REG}$ , and the gate voltage is held at  $V_{IN}$  through the resistor. The gate-source voltage of the MOSFET is 0V and the switch stays off. If a higher input voltage ( $V_{IN} + 5V$  for example) is suddenly applied with P DRV still in the OFF state, the source voltage of the MOSFET would jump up to  $V_{IN} + 5V$ , but the gate would still be at  $V_{IN}$ . The gate-source voltage becomes  $-5V$  and the P-channel MOSFET would turn on even though P DRV is still in the OFF state. In order to prevent the MOSFET from turning on, the gate clamp circuit senses the increase in the input voltage and pumps charge into the gate side of the coupling capacitor, quickly charging the capacitor to the new input voltage level.

The CLAMP pin requires a capacitor to GND in order for the gate clamp circuit to function properly. The capacitor value should be 1.5 to 2 times the value used for the coupling capacitor.

### BUCK CONTROLLERS

A block diagram of the buck controllers is shown in Figure 1. The circuit utilizes a constant ON-time PFM control architecture. The circuit determines the OFF-time by waiting for the inductor current to drop to a level set by the feedback voltage ( $V_{FB}$ ).

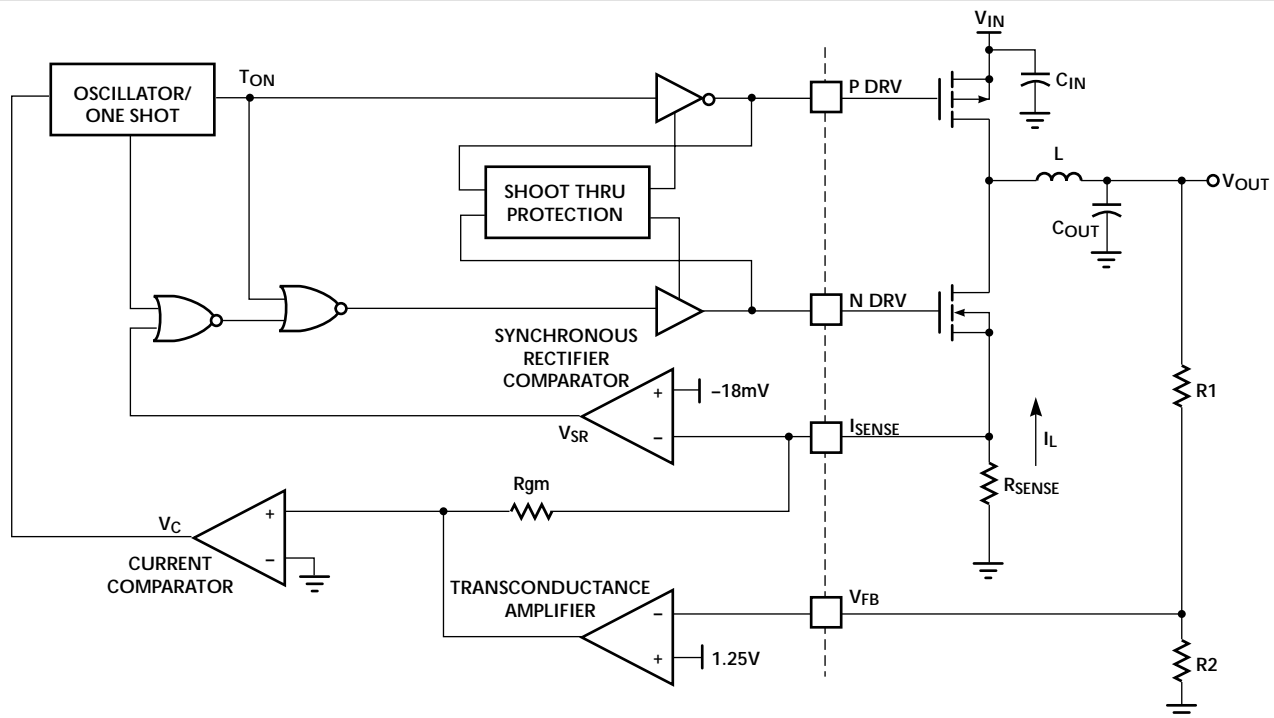

Figure 1. Buck Controller Functional Diagram

The oscillator/one shot block generates a constant ON-time and a minimum OFF-time. The OFF-time is extended for as long as the output of the current comparator stays low. Note that the inductor current flows in the current sense resistor during the OFF-time. Therefore, a minimum OFF-time is required to allow for the finite circuit delays in sensing the inductor current. The ON-time is triggered when the current comparator's output goes high. However, unlike conventional fixed ON-time controllers, the ML4880's one shot has an inverse relationship with the input voltage as shown in Figure 4. Figure 5 plots the inductor voltage-ON-time product. Note that the volt-second product is nearly constant at voltages above 7V input. This results in an inductor current ripple of:

$$\Delta I_L = \frac{T_{ON} \times (V_{IN} - V_{OUT})}{L} \quad (1)$$

It is important to note that the ripple current does not vary in proportion with  $V_{IN}$ , but remains nearly constant over a wide input voltage range.

The transconductance amplifier generates a current from the voltage difference between the reference and the feedback voltage,  $V_{FB}$ . This current produces a voltage across  $R_{gm}$  that adds to the negative voltage that is developed across the current sense resistor. When the current level in the inductor drops low enough (a less negative sense voltage) to cause the voltage at the non-inverting input of the current comparator to go positive, the comparator trips and starts a new ON cycle. In other words, the current programming comparator controls the length of the OFF-time by waiting until the inductor current decreases to a value determined by the transconductance amplifier.

This technique allows the feedback transconductance amplifier's output current to steer the current level in the inductor. The higher the transconductance amplifier's output current, the higher the inductor current. For example, when the output voltage drops due to a load increase, the transconductance amplifier will increase its output current and generate a larger voltage across  $R_{gm}$ ,

which in turn raises the inductor current trip level, shortening the OFF-time. At some level of increasing the output load, the transconductance amplifier can no longer continue to increase its output current. When this occurs, the voltage across  $R_{gm}$  reaches a maximum and the inductor current cannot increase. If the inductor current tries to increase, the voltage developed across the current sense resistor would become more negative, causing the non-inverting input of the current comparator to be negative, which extends the OFF-time and reduces the inductor current.

When the output voltage is too high, the transconductance amplifier's output current will eventually become negative. However, since the inductor current flows in only one direction (assuming no shoot through current) the non-inverting input of the current comparator will also stay negative. This extends the OFF-time allowing the inductor current to decrease to zero and causing the converter to stop operation until the output voltage drops enough to increase the output current of the transconductance amp above zero.

In summary, the three operation modes can be defined by the voltage at the  $I_{SENSE}$  pin at the end of the OFF-time:

$V_{SENSE} \geq 0V$	Discontinuous current mode
$0V > V_{SENSE} > -140mV$	Continuous current mode
$-140mV > V_{SENSE} > -250mV$	Current limit

The synchronous rectifier comparator and the two NOR gates make up the synchronous rectifier control circuit. The synchronous control does not influence the operation of the main control loop, and operation with a Schottky diode in place of the synchronous rectifier is possible, but at a lower conversion efficiency. The synchronous rectifier (N DRV) is turned on during the minimum OFF-time or whenever the  $I_{SENSE}$  pin goes below  $-18mV$ . N DRV will remain on until a new ON-time is started or until the  $I_{SENSE}$  pin goes above  $-18mV$ . When the  $I_{SENSE}$  pin goes above  $-18mV$ , the current in the inductor has gone to zero

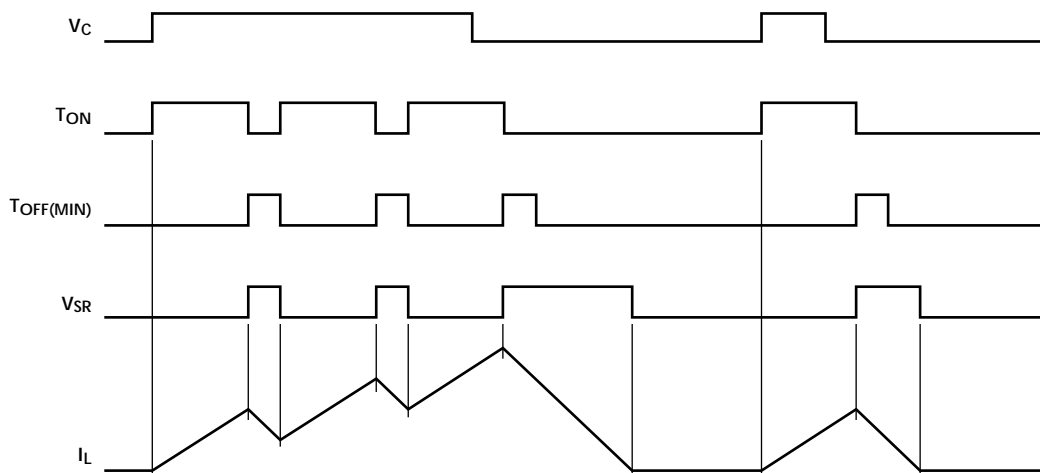

Figure 2. One Shot and Synchronous Rectifier Timing Diagram

or the buck regulator is operating in a discontinuous current mode (DCM). Therefore, the synchronous rectifier comparator is used only for DCM operation. A timing diagram is shown in Figure 2.

## FLYBACK CONTROLLER

A block diagram of the flyback regulator is shown in Figure 3. The circuit also utilizes a constant ON-time PFM control architecture. As with the buck controllers, the flyback controller determines the OFF-time by waiting for the inductor current to drop to a level set by the feedback voltage  $V_{FB}$ . As a result of the control scheme, the valley of the inductor current ripple is programmed instead of the peak, and features an automatic transition into and out of burst mode which does not require additional control circuitry.

The flyback controller's oscillator/one shot block has a constant ON-time and a minimum OFF-time similar to that of the buck controllers. The OFF-time is extended for as long as the current comparator's output stays low. Again, since the inductor current flows in the current sense resistor during the OFF-time, a minimum OFF-time is required to allow for the finite circuit delays in sensing the inductor current. The ON-time is triggered when the current comparator's output goes high. However, unlike conventional fixed ON-time controllers, the ML4880's one shot has an inverse relationship with the input voltage as shown in Figure 4. Figure 5 plots the inductor voltage-ON-time product. Note that the volt-second product is nearly constant over the input voltage range. This results in an inductor current ripple of:

$$\Delta I_L = \frac{T_{ON} \times V_{IN}}{L} \quad (2)$$

It is important to note that the ripple current does not vary in proportion with  $V_{IN}$ , but remains nearly constant over a wide input voltage range.

The transconductance amplifier and current comparator operate in the same manner as the buck regulator. The current programming comparator controls the length of the OFF-time by waiting until the inductor current decreases to a value determined by the transconductance amplifier before starting a new ON-time.

Like the buck controllers, when the flyback's output voltage drops due to a load increase, the transconductance amplifier will increase its output current and generate a larger voltage across  $R_{gm}$ , which in turn causes the current comparator's output to go positive earlier or shortens the OFF-time. Conversely, when the output voltage is too high, the transconductance amplifier's output current will eventually become negative. This holds the current comparator's output low and extends the OFF-time causing the converter to stop operation until the output voltage drops enough to increase the output current of the transconductance amp above zero.

In summary, the flyback has three operation modes that can be defined by the voltage at the SENSE pin at the end of the OFF-time:

$V_{SENSE} \geq 0V$	Discontinuous current mode
$0V > V_{SENSE} > -140mV$	Continuous current mode
$-140mV > V_{SENSE} > -250mV$	Current limit

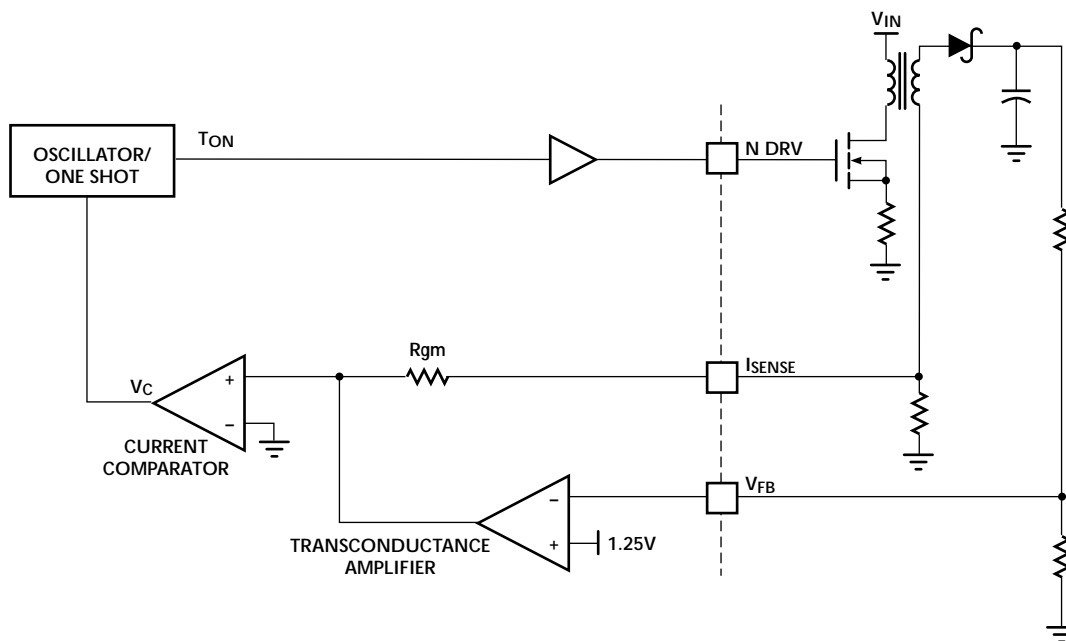

Figure 3. Flyback Controller Functional Diagram

## DESIGN CONSIDERATIONS

A typical design can be implemented by using the following design procedure. Note that this procedure is not intended to give final values, but to give a good starting point, and provide the relationships necessary to make trade-off decisions. Some experimentation will be necessary to optimize values and to verify that the design operates over worst case conditions.

### DESIGN SPECIFICATIONS

It is important to start with a clear definition of the design specifications. Make sure the specifications reflect worst case conditions. Key specifications include the minimum and maximum input voltage and the output voltage and load current for each output.

### BUCK REGULATORS - INDUCTOR AND SENSE RESISTOR SELECTION

Figure 6 shows the inductor current of the step down regulators. The inductor current is made up of two components: the DC current level set by the transconductance amplifier,  $I_{SENSE}$ , and the inductor ripple current,  $\Delta I_L$ . The figure also shows that  $I_{OUT}$  is the summation of  $I_{SENSE}$  and  $1/2 \Delta I_L$ :

$$I_{OUT} = I_{SENSE} + \frac{1}{2} \Delta I_L = \frac{V_{SENSE}}{R_{SENSE}} + \frac{T_{ON} \times (V_{IN} - V_{OUT})}{2 \times L} \quad (3)$$

Therefore, the selection of the inductance value determines how much of the output current is made up of the ripple current. Higher inductor ripple current allows smaller inductor values, but results in higher peak currents, lower efficiency, and higher output voltage ripple.

Inductor ripple currents in the range of 30% to 70% of the maximum output current are typical. As a good starting point set the inductor ripple current to 50% of the maximum output current:

$$\Delta I_L = \frac{T_{ON} \times (V_{IN} - V_{OUT})}{L} = F_{IRC} \times I_{OUT(MAX)} \quad (4)$$

where  $F_{IRC}$  = ratio of inductor ripple current to the maximum output current, or:

$$L = \frac{T_{ON} \times (V_{IN} - V_{OUT})}{0.5 \times I_{OUT(MAX)}} \quad (5)$$

Calculate the inductance using the volt-seconds value given in Figure 5 at the maximum input voltage. Choose the nearest standard value, realizing the trade-offs mentioned before. Then, using the inductance value chosen, determine the actual inductor ripple current at the maximum and minimum input voltage using Equation 4 and Figure 5.

The sense resistor value can be determined using the inductor ripple current value calculated above and Equation 3 rearranged as follows:

$$R_{SENSE} = \frac{V_{SENSE(MIN)}}{I_{OUT(MAX)} - \frac{1}{2} \Delta I_{L(MIN)}} = \frac{0.14}{I_{OUT(MAX)} - \frac{1}{2} \Delta I_{L(MIN)}} \quad (6)$$

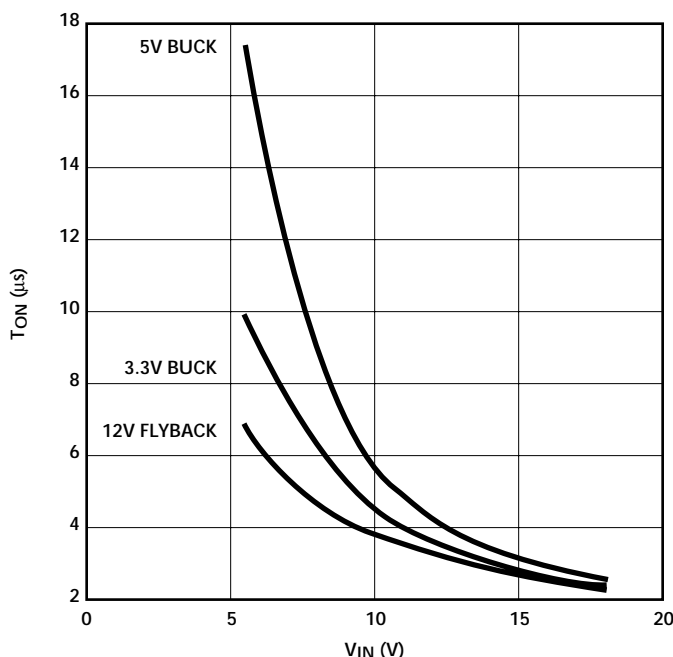

Figure 4.  $T_{ON}$  vs.  $V_{IN}$

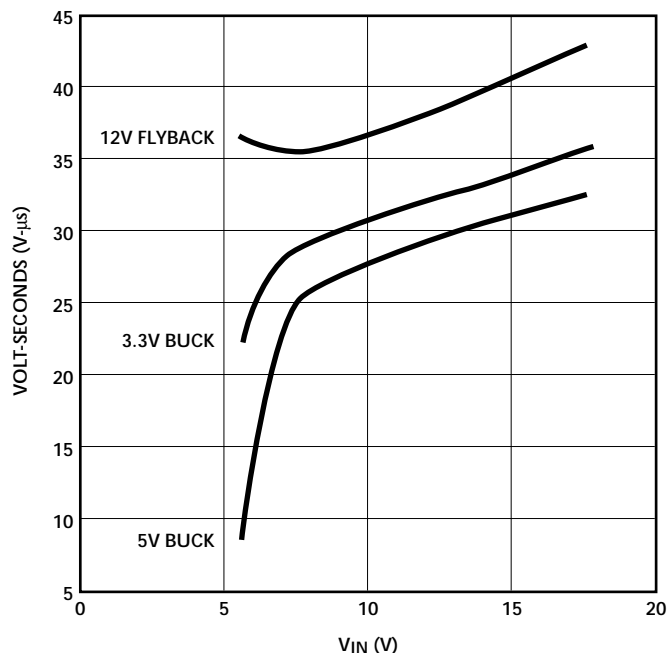

Figure 5. Volt-seconds vs  $V_{IN}$

Having determined the values for the inductor and sense resistor, we can now specify the inductor peak current rating. This value is calculated at current limit and at the maximum input voltage, and is given by:

$$I_{L(PK@MAX)} = I_{SENSE(MAX)} + \Delta I_{L(MAX)} = \frac{V_{SENSE(MAX)}}{R_{SENSE}} + \Delta I_{L(MAX)} = \frac{0.25V}{R_{SENSE}} + \Delta I_{L(MAX)} \quad (7)$$

For reliable operation, the inductor current rating should exceed the value calculated by 10%-20%.

For future reference, determine the peak inductor current at the minimum input voltage:

$$I_{L(PK@MIN)} = I_{SENSE(MAX)} + \Delta I_{L(MIN)} = \frac{V_{SENSE(MAX)}}{R_{SENSE}} + \Delta I_{L(MIN)} = \frac{0.25V}{R_{SENSE}} + \Delta I_{L(MIN)} \quad (8)$$

Now the sense resistor's power rating can be determined. The sense resistor must be able to carry the peak current in the inductor during the OFF-time:

$$P_{R_{SENSE}} = I_{RMS(OFF)}^2 \times R_{SENSE} \quad (9)$$

where,

$$I_{RMS(OFF)}^2 = \left(1 - \frac{V_{OUT}}{V_{IN(MAX)}}\right) \left[ \frac{(I_{SENSE(MAX)})^2 + (I_{SENSE(MAX)}) (I_{L(PK@MAX)}) + (I_{L(PK@MAX)})^2}{3} \right]$$

One final parameter should be specified: the winding resistance of the inductor. In general the winding resistance should be as low as possible, preferably in the low mΩ range. Since the inductor is in series with the load at all times, the copper losses can be approximated by:

$$P_{CU} = I_{OUT}^2 \times R_L \quad (10)$$

A good rule of thumb is to allow 2mΩ of winding resistance per μH of inductance.

## BUCK REGULATORS — MOSFET SELECTION

The switching MOSFETs must be logic level types with the ON resistance specified at  $V_{GS} = 4.5V$ . In general, the ON resistance - gate charge product provides a good figure of merit by which to compare various MOSFETs, the lower the figure the better. The internal gate drivers of the ML4880 can drive over 100nC of total gate charge, but 60nC to 70nC is a more practical limit to ensure good switching times.

The drain-source breakdown voltage rating is determined by the input voltage. For input voltages up to 12V, a drain to source rating of 20V is acceptable. For input voltages up to 18V, a drain to source rating of 30V is recommended. For a more reliable design, look for MOSFETs that are avalanche rated.

In high current applications, the MOSFET's power dissipation often becomes a major design factor. The  $I^2R$  losses generate the largest portion of heat in the MOSFET package. Make sure that the MOSFETs are within their rated junction temperature at the maximum ambient temperature by calculating the temperature rise using the thermal resistance specifications.

The worst case power dissipation for the P-MOS switch occurs at the minimum input voltage and is determined as follows:

$$P_{(P-MOS)} = I_{RMS(ON)}^2 \times R_{DS(ON)} \quad (11)$$

where

$$I_{RMS(ON)}^2 = \left(\frac{V_{OUT}}{V_{IN(MIN)}}\right) \left[ \frac{(I_{SENSE(MAX)})^2 + (I_{SENSE(MAX)}) (I_{L(PK@MIN)}) + (I_{L(PK@MIN)})^2}{3} \right]$$

The worst case power dissipation for the N-MOS switch occurs at the maximum input voltage and is determined using:

$$P_{(N-MOS)} = I_{RMS(OFF)}^2 \times R_{DS(ON)} \quad (12)$$

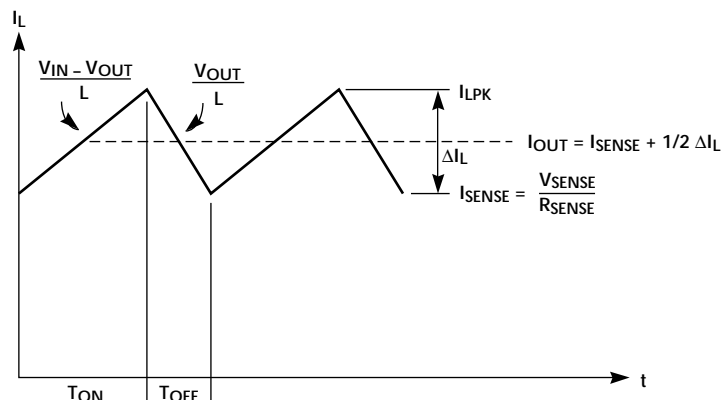

Figure 6. Buck Regulator Inductor Current



## BUCK REGULATORS — INPUT CAPACITOR SELECTION

The choice of the input capacitor is based on its ripple current and voltage ratings rather than its capacitance value. The input capacitor should be a low ESR type and located as close to the source of the P-MOS switch as possible. The input capacitor's ripple current is determined by the load current and the input voltage, with the worst case condition occurring at  $V_{IN} = 2 \times V_{OUT}$ :

$$I_{RMS(C_{IN})} \approx \left( I_{SENSE(MAX)} + \frac{1}{2} \Delta I_L(MAX) \right) \left( \frac{\sqrt{V_{OUT}(V_{IN} - V_{OUT})}}{V_{IN}} \right) \quad (13)$$

The capacitor's voltage rating is based on the maximum input voltage,  $V_{IN(MAX)}$ . Capacitor manufacturers typically recommend derating the capacitor voltage rating by 20% to 50% for aluminum electrolytic types and 50% to 70% for tantalum types.

In high current applications it may necessary to add a 10 $\mu$ F bulk capacitor and a small 0.1 $\mu$ F ceramic capacitor to bypass  $V_{IN}$  (pin 16) right at the ML4880.

## BUCK REGULATORS — OUTPUT CAPACITOR SELECTION

The output capacitors determine the loop stability and the output ripple voltage. Use only low ESR capacitors intended for switching power supply applications, such as AVX TPS, Sprague 593D Sanyo OS-CON, or Nichicon PL series. To ensure stability, the minimum capacitance value is given by:

$$C_{OUT} \geq \left( \frac{4.3}{V_{OUT}} \right) \left( \frac{T_{ON(MAX)}}{R_{SENSE}} \right) \quad (14)$$

The maximum ESR value can be estimated using:

$$ESR \leq \frac{\Delta V_{OUT}}{\Delta I_L(MAX)} \quad (15)$$

The selected capacitor must meet both the capacitance and ESR requirements. As a final check, make sure the output capacitor can handle the ripple current,  $I_{RMS(C_{OUT})}$ :

$$I_{RMS(C_{OUT})} \approx \frac{\Delta I_L(MAX)}{\sqrt{12}} \quad (16)$$

## BUCK REGULATORS - OUTPUT VOLTAGE

The output of buck regulator A is adjustable and can be set to any voltage between 2.5V and 3.5V by connecting a resistor divider to the feedback pin as shown in Figure 1. Similarly, the output voltage of buck regulator B is adjustable and has a usable range of 4.5V to 5.0V. The resistor values R1 and R2 can be calculated using the following equation:

$$V_{OUT} = 1.25V \times \left( \frac{R1 + R2}{R2} \right) \quad (17)$$

The value of R2 should be 125k $\Omega$  or less to minimize bias current errors.

It is important to note that the accuracy of these resistors directly affects the accuracy of the output. Use precision resistors and set the nominal voltage approximately 1% to 2% high with no load in order to make up for the drops that normally occur when supplying heavy loads. This offset results in the best overall output accuracy over line and load.

## FLYBACK REGULATOR — INDUCTOR AND SENSE RESISTOR SELECTION

Figure 7 shows the inductor current of the flyback regulator. The inductor current is made up of two components: the DC current level set by the transconductance amplifier,  $I_{SENSE}$ , and the inductor ripple current,  $\Delta I_L$ . Therefore, the selection of the inductance value determines how much of the output current is made up of the inductor ripple current. Higher inductor ripple current allows smaller inductor values, but results in higher peak currents, lower efficiency, and higher output voltage ripple.

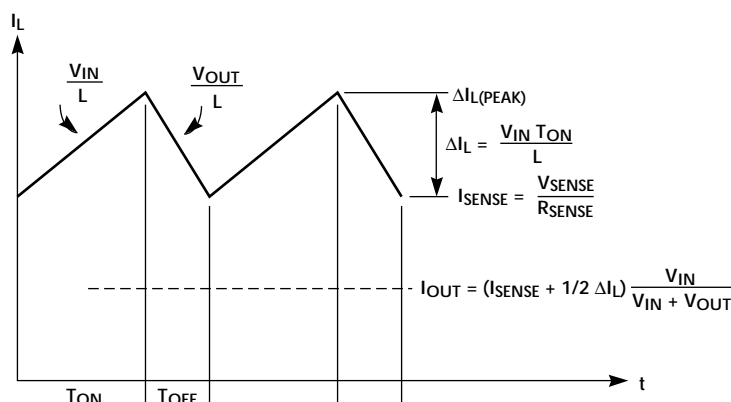

Figure 7. Flyback Regulator Inductor Current

The relationship of the inductor current to the output current is given by the following equation:

$$I_{OUT} = \left( I_{SENSE} + \frac{1}{2} \Delta L \right) \left( \frac{V_{IN}}{V_{IN} + V_{OUT}} \right) = \left( \frac{V_{SENSE}}{R_{SENSE}} + \frac{T_{ON} \times V_{IN}}{2 \times L} \right) \left( \frac{V_{IN}}{V_{IN} + V_{OUT}} \right) \quad (18)$$

The inductance value can be determined by setting the ripple current portion of Equation 18 to some percentage of the output current. Inductor ripple currents in the range of 50% to 80% of the maximum output current are typical. As a good starting point set the inductor ripple current to 65% of the maximum output current:

$$\Delta L = \frac{T_{ON} \times V_{IN}}{L} = F_{IRC} \times I_{OUT(MAX)} \times \left( \frac{V_{IN} + V_{OUT}}{V_{IN}} \right) \quad (19)$$

where  $F_{IRC}$  = ratio of inductor ripple current to the maximum output current, or:

$$L = \frac{T_{ON} \times V_{IN(MIN)}}{0.65 \times I_{OUT(MAX)}} \left( \frac{V_{IN(MIN)}}{V_{IN(MIN)} + V_{OUT}} \right) \quad (20)$$

Calculate the inductance using the volt-seconds value given in Figure 5 at the minimum input voltage. Choose the nearest standard value, and determine the actual inductor ripple current at the maximum and minimum input voltage using Equation 19 and Figure 5.

Next, determine the sense resistor value using the inductor ripple current value calculated above using:

$$R_{SENSE} = \frac{V_{SENSE(MIN)}}{I_{OUT(MAX)} \left( \frac{V_{IN(MIN)} + V_{OUT}}{V_{IN(MIN)}} \right) - \frac{1}{2} \Delta L(MIN)}$$

$$= \frac{0.14}{I_{OUT(MAX)} \left( \frac{V_{IN(MIN)} + V_{OUT}}{V_{IN(MIN)}} \right) - \frac{1}{2} \Delta L(MIN)} \quad (21)$$

Having determined the values for the inductor and sense resistor, the inductor peak current rating can now be specified. This value is calculated at current limit and at the maximum input voltage, and is given by:

$$I_{L(PK @ MAX)} = I_{SENSE(MAX)} + \Delta L_{L(MAX)}$$

$$= \frac{V_{SENSE(MAX)}}{R_{SENSE}} + \Delta L_{L(MAX)} = \frac{0.25V}{R_{SENSE}} + \Delta L_{L(MAX)} \quad (22)$$

For reliable operation, the inductor current rating should exceed the value calculated by 10%-20%.

Now the sense resistor's power rating can be determined. The sense resistor must be able to carry the peak current in the inductor, but only during the OFF-time:

$$P_{R_{SENSE}} = I_{RMS(OFF)}^2 \times R_{SENSE} \quad (23)$$

where,

$$I_{RMS(OFF)}^2 = \left( \frac{V_{IN(MAX)}}{V_{IN(MAX)} + V_{OUT}} \right) \left[ \frac{I_{SENSE(MAX)}^2 + I_{SENSE(MAX)} I_{L(PK @ MAX)} + I_{L(PK @ MAX)}^2}{3} \right]$$

The winding resistance and the turns ratio of the coupled inductor need to be specified. In general the winding resistance should be as low as possible, preferably in the low milliohm range. A good rule of thumb is to allow 2 mW of winding resistance per mH of inductance. The turns ratio is specified at 1:1 for simplicity and availability.

## FLYBACK REGULATOR - MOSFET SELECTION

The internal gate drive of the ML4880 limits the selection of the switching FET to logic level types with the ON resistance specified at  $V_{GS} = 4.5V$ . Also, look for a FET with a maximum total gate charge of around 70nC.

The drain to source breakdown voltage rating is determined as follows:

$$V_{DS} = (V_{IN(MAX)} + V_{OUT}) \times F_{DS} \quad (24)$$

A safety derating factor,  $F_{DS}$ , in the range of 1.5 to 2.0 is recommended due to the voltage spikes caused by the leakage inductance of a transformer. For a more reliable design, look for MOSFETs that are avalanche rated.

The maximum ON resistance of the MOSFET can be determined using the worst case power dissipation for the package type chosen. This assumes that the major portion of heat generated in the package is due to I<sup>2</sup>R losses.

$$R_{DS(ON)} = \frac{P_{PKG}}{I_{RMS(ON)}^2} \quad (25)$$

where,

$$I_{RMS(ON)}^2 = \left( \frac{V_{OUT}}{V_{IN(MIN)} + V_{OUT}} \right) \left[ \frac{I_{SENSE(MAX)}^2 + I_{SENSE(MAX)} I_{L(PK @ MAX)} + I_{L(PK @ MAX)}^2}{3} \right]$$

## FLYBACK REGULATOR — RECTIFIER SELECTION

The output diode must be able to carry the worst case output current as well as withstand the worst case reverse voltage. The worst case output current occurs at current limit and at the maximum input voltage. Therefore, the average forward current rating of the output diode can be determined by the following:

$$I_{D(AVG)} = \frac{I_{OUT(MAX)}}{F_{ID}} = \left( \frac{0.25}{R_{SENSE}} + \frac{T_{ON} \times V_{IN(MAX)}}{2 \times L} \right) \left( \frac{V_{IN(MAX)}}{V_{IN(MAX)} + V_{OUT}} \right) \left( \frac{1}{F_{ID}} \right)$$

where,

$$F_{ID} = \text{derating factor} \quad (26)$$

The derating factor is typically in the range of 0.5 to 0.9 depending on reliability goals. Typically a value of 0.8 is used for most applications.

The reverse voltage rating is determined by the sum of the output voltage and the maximum input voltage:

$$V_R = \frac{V_{OUT} + V_{IN(MAX)}}{F_{VR}} \quad (27)$$

where,

$F_{VR}$  = derating factor

Again a derating factor of 0.8 is typical for most applications.

### FLYBACK REGULATOR - INPUT CAPACITOR SELECTION

The input capacitor should be a low ESR type and located as close to the primary winding of the transformer as possible. The capacitor's ability to handle ripple current is the selection criteria used. The input capacitor's ripple current is determined by the load current and the input voltage, with the worst case condition occurring at  $V_{IN} = V_{OUT}$ .

$$I_{RMS(C_{IN})} \approx \left( I_{SENSE(MAX)} + \frac{1}{2} \Delta I_{L(MAX)} \right) \left( \frac{\sqrt{V_{OUT} \times V_{IN}}}{V_{OUT} + V_{IN}} \right) \quad (28)$$

The capacitor must also be able to handle the maximum input voltage. For reliable operation derate the capacitor voltage rating by 20% to 50% for aluminum electrolytic types and 50% to 70% for tantalum types.

### FLYBACK REGULATOR - OUTPUT CAPACITOR SELECTION

The output capacitors determine the flyback regulator's loop stability and the output ripple voltage. Use only low ESR capacitors intended for switching power supply applications. To ensure stability, the minimum capacitance value is given by:

$$C_{OUT} \geq \left( \frac{8.6}{V_{OUT}} \right) \left( \frac{T_{ON(MAX)}}{R_{SENSE}} \right) \left( \frac{I_{OUT(MAX)}}{\Delta I_{L(MIN)}} \right) \quad (29)$$

The maximum ESR value can be estimated using:

$$ESR \leq \frac{\Delta V_{OUT}}{\Delta I_{L(MAX)}} \quad (30)$$

The selected capacitor must meet both the capacitance and ESR requirements. As a final check, make sure the output capacitor can handle the ripple current,  $I_{RMS(C_{OUT})}$ .

$$I_{RMS(C_{OUT})} \approx I_{RMS(C_{IN})} \quad (31)$$

### FLYBACK REGULATOR - OUTPUT VOLTAGE

The output of the flyback regulator is adjustable and can be set to any voltage between 6.0V and 15.0V by connecting a resistor divider to the feedback pin as shown in Figure 3. The resistor values R1 and R2 can be calculated using the following equation:

$$V_{OUT} = 1.25V \times \left( \frac{R1 + R2}{R2} \right) \quad (32)$$

The value of R2 should be 125kΩ or less to minimize bias current errors.

It is important to note that the accuracy of these resistors directly affects the accuracy of the output. Use precision resistors and set the nominal voltage approximately 1% to 2% high in order to make up for the ML4880's load regulation. This offset results in the best overall output accuracy over line and load.

## LAYOUT

Proximity of passive devices and adequate power and ground planes are critical for reliable operation of the circuit. In general, use the top layer for the high current connections and the bottom layer for the quiet connections such as GND, feedback and current sense. Some more specific guidelines follow.

1. The connection from the current sense resistor to the  $I_{SENSE}$  pin should be made by a separate trace and located as close to the lead of the resistor as possible. The trace length from the sense resistor to the ML4880 should be kept as short as possible and away from switching components and their traces.
2. The trace lengths from the buck regulator's input capacitor to the switching MOSFET, from the MOSFETs to the inductor, from the synchronous rectifier MOSFET to the SENSE resistor, and from the inductor to the output capacitor should all be as short as possible. The flyback regulator's trace length from the input capacitor to the inductor, from the inductor to the MOSFET, from the sense resistor to the inductor, and from the diode to the output capacitor should also be kept short to minimize noise and ground bounce.
3. The high current ground paths need to be kept separate from the signal ground paths. The GND connection should be made at a single-point star ground. It is very important that the ground for the ML4880 ground pins (pins 6 and 7) be made using a separate trace.
4. Note: Concentrating on keeping the current sense and high current connections short as well as keeping the switching components and traces away from the sensitive analog components and traces during layout will eliminate the majority of problems created by a poor layout.
5. The  $V_{IN}$  and  $V_{REG}$  bypass capacitors need to be located close to the ML4880 for adequate filtering of the IC's internal bias voltage.
6. Remote sensing the output for improved load regulation can be implemented with the ML4880. Any output can be remote sensed by using the top of the external resistor divider as the remote sense point.

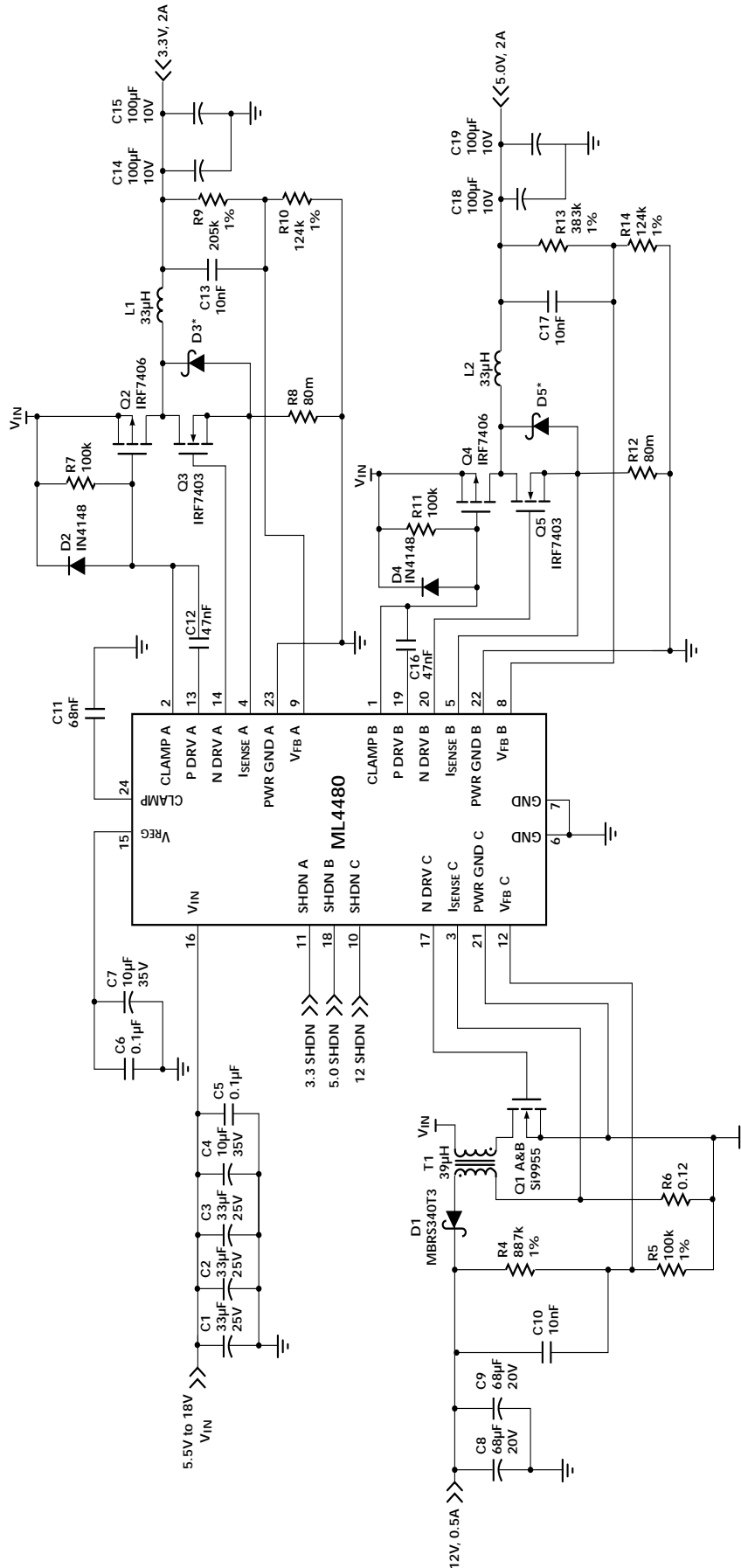

\*Optional

Figure 8. Typical Application Circuit

## SUGGESTED VENDORS

See Table 1 for a list of suggested component manufacturers.

**TABLE 1: COMPONENT SUPPLIERS**

COMPONENT	MANUFACTURER	PART NUMBER	PHONE
SENSE RESISTORS	Dale	WSL Series	(402) 563-6506
	IRC	LRC Series	(512) 992-7900
INDUCTORS	Coilcraft	DO/DT Series	(708) 639-6400
	Coiltronics	OCTA-PAC Series	(305) 781-8900
	Dale	LPE-6562 Series	(605) 665-9301
		LPT-4545 Series	
	Premier Magnetics	VTK & HTK Series	(714) 362-4211
	Pulse Engineering	LCI & HCI Series	(619) 674-8100
	Sumida	CD & CDR Series	(708) 956-0666
	XFMRS, Inc.	Surface Mt Series	(317) 834-1066
CAPACITORS	AVX	TPS Series	(207) 282-5111
	Sprague	593D Series	(708) 956-0667
	Sanyo	SC & SA Series	(619) 661-6835
	Nichicon	PL Series	(708) 843-7500
	Panasonic	HFQ Series	(201) 348-5227
SEMICONDUCTORS	Diodes, Inc.	SK Series	(805) 446-4800
	International Rectifier	IRF7XXX Series	(310) 322-3331
	Motorola	MMSF Series	(602) 302-8056
		MMDF Series	
	National Semiconductor	NDS94XX	(800) 272-9959
		NDS99XX	
	Siliconix	Littlefoot Series	(408) 970-5700
		Litefoot Series	

## PHYSICAL DIMENSIONS inches (millimeters)

Package: S24  
24-Pin SOIC

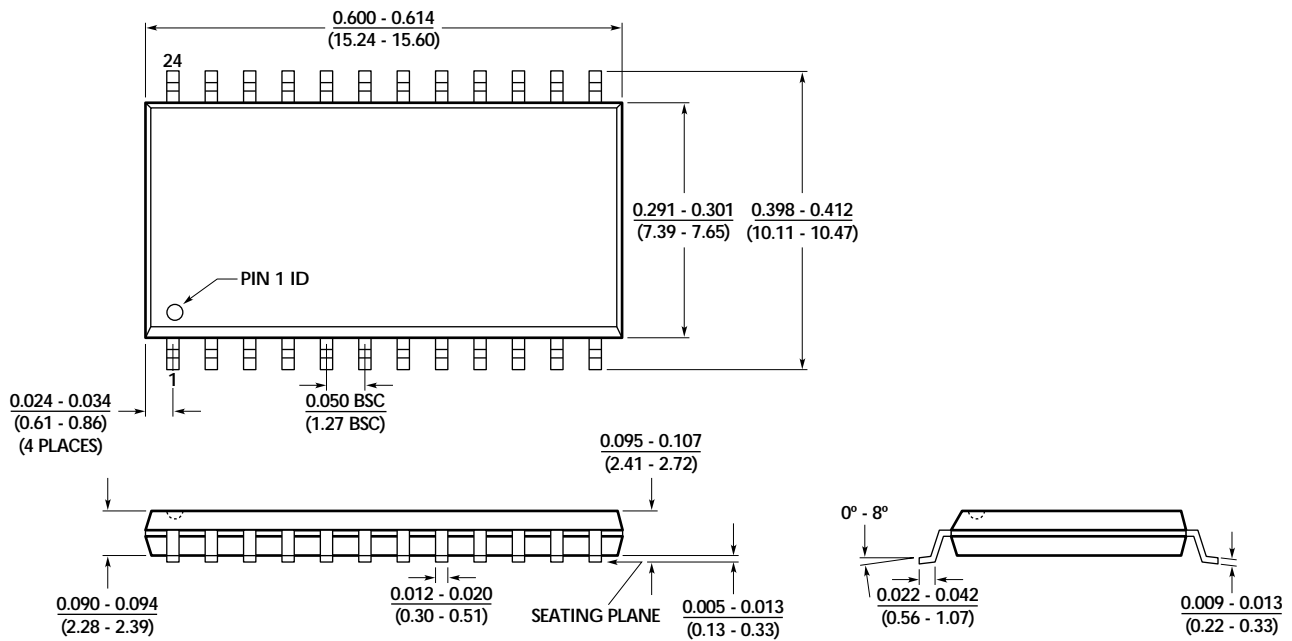

## ORDERING INFORMATION

PART NUMBER	TEMPERATURE RANGE	PACKAGE
ML4880CS	0°C to 70°C	24-PIN SOIC (S24) (End Of Life)
ML4880ES	-20°C to 70°C	24-PIN SOIC (S24) (Obsolete)

© Micro Linear 1997.  **Micro Linear** is a registered trademark of Micro Linear Corporation

Products described in this document may be covered by one or more of the following patents, U.S.: 4,897,611; 4,964,026; 5,027,116; 5,281,862; 5,283,483; 5,418,502; 5,508,570; 5,510,727; 5,523,940; 5,546,017; 5,559,470; 5,565,761; 5,592,128; 5,594,376; Japan: 2598946; 2619299. Other patents are pending.

Micro Linear reserves the right to make changes to any product herein to improve reliability, function or design. Micro Linear does not assume any liability arising out of the application or use of any product described herein, neither does it convey any license under its patent right nor the rights of others. The circuits contained in this data sheet are offered as possible applications only. Micro Linear makes no warranties or representations as to whether the illustrated circuits infringe any intellectual property rights of others, and will accept no responsibility or liability for use of any application herein. The customer is urged to consult with appropriate legal counsel before deciding on a particular application.

2092 Concourse Drive  
San Jose, CA 95131  
Tel: 408/433-5200  
Fax: 408/432-0295

DS4880-01