

High Frequency Power Supply Controller

GENERAL DESCRIPTION

The ML4810 and ML4811 High Frequency PWM Controllers are optimized for use in Switch Mode Power Supply designs running at frequencies to 1MHz. The ML4810/11 contain a unique overload protection circuit which helps to limit stress on the output devices and reliably performs a soft-start reset. These controllers are designed to work in either voltage or current mode and provide for input voltage feed forward.

A 1.1V threshold current limit comparator provides a cycle-by-cycle current limit. An integrating circuit "counts" the number of times the 1.1V limit was reached. A soft-start cycle is initiated if the cycle-by-cycle current limit is repeatedly activated. A reset delay function is provided on the ML4811.

These controllers are similar to the UC1825 controller, however these controllers include many features not found on the 1825. These features are set in *Italics*.

FEATURES

- *Integrating Soft Start Reset*
- High current (2A peak) dual totem pole outputs
- Practical operation to 1MHz (f_{OSC})
- 5.1V ±2% trimmed bandgap reference
- *Under voltage lockout with 7V hysteresis*
- *Soft Start Reset Delay (ML4811)*
- *Oscillator synchronization function (ML4811)*
- *Soft Start latch ensures full soft start cycle*
- *Outputs pull low for undervoltage lockout*
- *Accurately controlled oscillator ramp discharge current*
- *All timing currents "slaved" to R_T for precise control*

* This part is End of Life as of August 1, 2000

** This part is Obsolete

BLOCK DIAGRAM (Pin numbers shown are for ML4811)

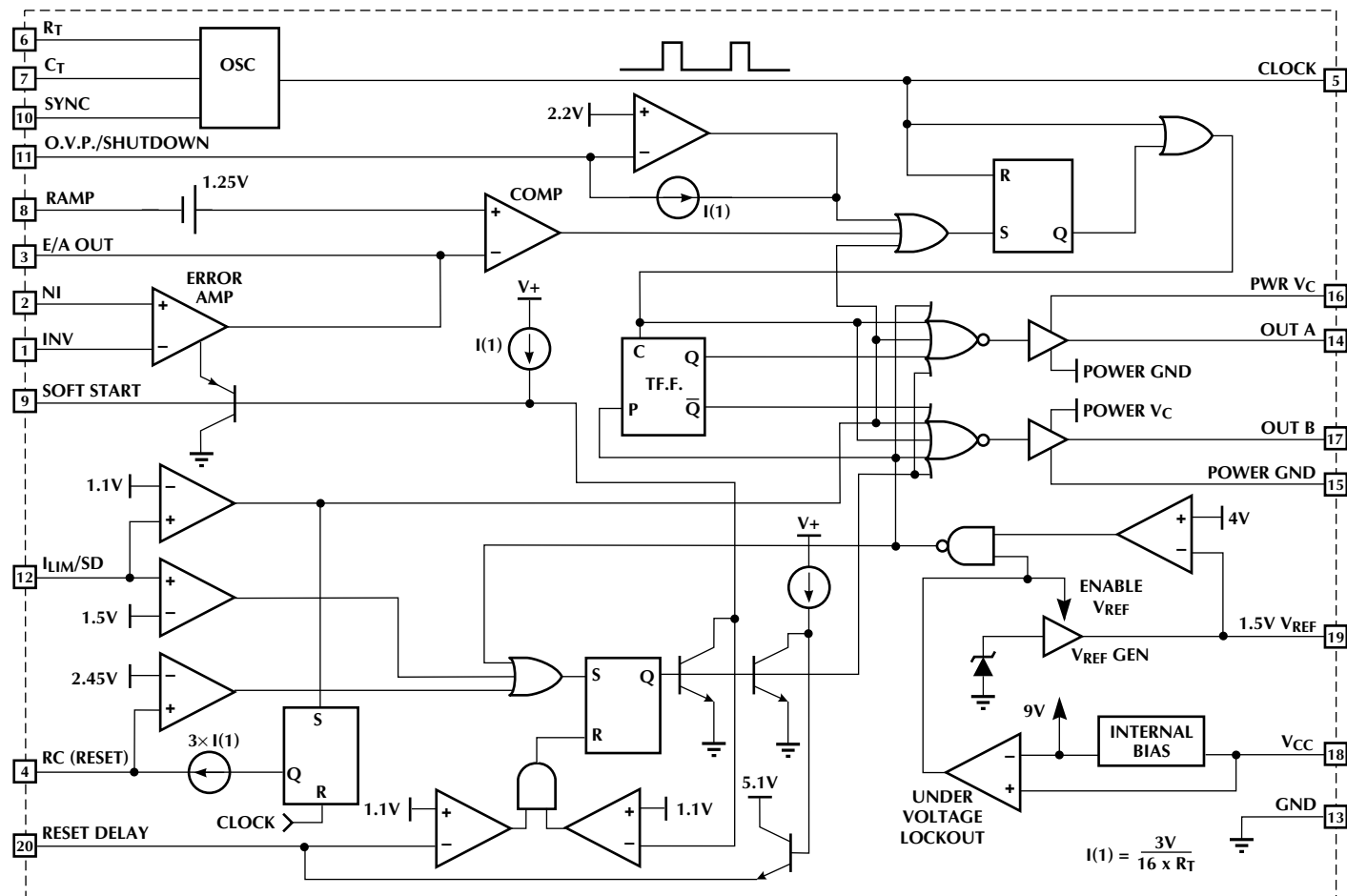

PIN CONFIGURATION

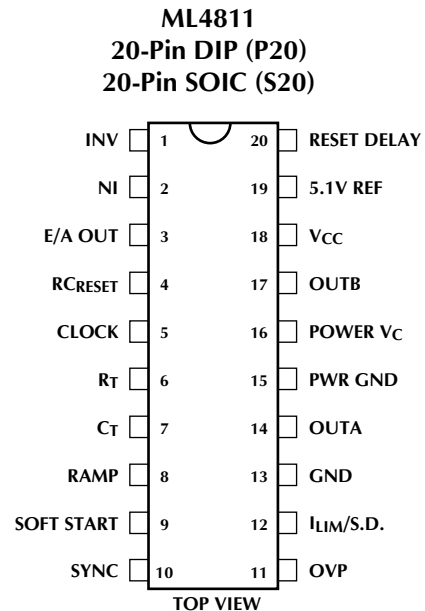
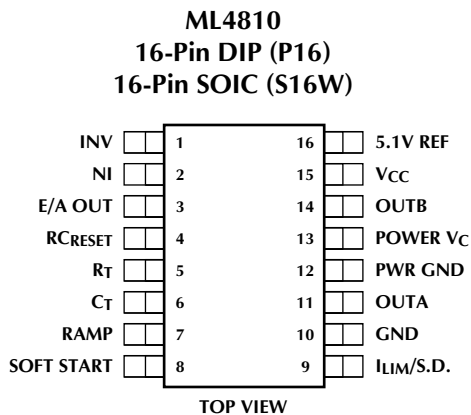

PIN DESCRIPTION

PIN	NAME	FUNCTION	PIN	NAME	FUNCTION
1	INV	Inverting input to error amp.	11	OVP	Exceeding 2.5V terminates the PWM cycle and inhibits the outputs.
2	NI	Non-inverting input to error amp.	12	I _{LIM} /S.D.	Current limit sense pin. Normally connected to current sense resistor.
3	E/A OUT	Output of error amplifier and input to main comparator.	13	GND	Analog signal ground.
4	RC _{RESET}	Timing elements for Integrating Soft Start reset.	14	OUTA	High current totem pole output. This output is the first one energized after power on reset.
5	CLOCK	Oscillator output.	15	PWR GND	Return for the high current totem pole outputs.
6	R _T	Timing resistor for oscillator — sets charging current for oscillator timing capacitor (pin 6).	16	V _C	Positive supply for the high current totem pole outputs.
7	C _T	Timing capacitor for oscillator.	17	OUTB	High current totem pole output.
8	RAMP	Non-inverting input to main comparator. Connected to C _T for voltage mode operation or to current sense resistor for current mode.	18	V _{CC}	Positive supply for the IC.
9	SOFT START	Normally connected to Soft Start capacitor.	19	5.1V REF	Buffered output for the 5.1V voltage reference.
10	SYNC	A high going pulse terminates the PWM cycle and discharges C _T .	20	RESET DELAY	Timing capacitor to determine the amount of delay between fault.

ABSOLUTE MAXIMUM RATINGS

Absolute maximum ratings are those values beyond which the device could be permanently damaged. Absolute maximum ratings are stress ratings only and functional device operation is not implied.

Supply Voltage (Pins 18, 16)	25V
Output Current, Source or Sink (Pins 14, 17)	
DC	0.5A
Pulse (0.5 μ s)	2.0A
Analog Inputs	
(Pins INV, NI, SOFT START)	-0.3V to 7V
(Pins 9, 10, 11, 12, 20)	-0.3V to 6V

Clock Output Current (Pins 5)	-5mA
Error Amplifier Output Current (Pin 3)	5mA
Junction Temperature	150°C
Storage Temperature Range	-65°C to 150°C
Lead Temperature (Soldering 10 sec.)	260°C
Thermal Resistance (θ_{JA})	
Plastic DIP	65°C/W
Plastic SOIC	65°C/W

OPERATING CONDITIONS

Temperature Range	
ML4810, ML4811	0°C to 70°C

ELECTRICAL CHARACTERISTICS

Unless otherwise specified, $V_{CC} = 15V$, $R_T = 3.65k\Omega$, $C_T = 1000pF$, $T_A =$ Operating Temperature Range. (Note 1)

PARAMETER	CONDITIONS	MIN	TYP	MAX	UNITS
OSCILLATOR					
Initial Accuracy	$T_J = 25^\circ C$	360	400	440	kHz
Voltage Stability	$10V < V_{CC} < 25V$		0.2	4	%
Temperature Stability			5		%
Total Variation	line, temperature	340		460	kHz
Clock Out High		3.9	4.5		V
Clock Out Low			2.3	2.9	V
Ramp Peak			2.8		V
Ramp Valley			1.0		V
Ramp Valley to Peak		1.6		2.3	V
Sync Input Threshold		0.8	1.0	1.4	V
Sync Input Current	SYNC = 4V				μA
REFERENCE					
Output Voltage	$T_J = 25^\circ C, I_O = 1mA$	5.00	5.10	5.20	V
Line Regulation	$10V < V_{CC} < 25V$		2	20	mV
Load Regulation	$1mA < I_O < 10mA$		5	20	mV
Temperature Stability	$0^\circ C < T_J < 150^\circ C$		0.2	0.4	%
Total Variation	line, load, temperature	4.95		5.25	V
Output Noise Voltage	10Hz to 10kHz		50		μV
Long Term Stability	$T_J = 125^\circ C, 1000$ hrs		5	25	mV
Short Circuit Current	$V_{REF} = 0V$	-15	-50	-100	mA
UNDERVOLTAGE LOCKOUT					
Start Threshold		15	16	17	V
UVLO Hysteresis		6.5	7	7.5	V
ERROR AMPLIFIER					
Input Offset Voltage				± 20	mV
Input Bias Current			0.6	3	μA
Input Offset Current			0.1	1	μA
Open Loop Gain	$1 < V_O < 4V$	60	96		dB

ML4810, ML4811

ELECTRICAL CHARACTERISTICS (Continued)

PARAMETER		CONDITIONS	MIN	TYP	MAX	UNITS
ERROR AMPLIFIER (Continued)						
CMRR		$1.5 < V_{CM} < 5.5V$	65	95		dB
PSRR		$10 < V_{CC} < 30V$	75	90		dB
Output Sink Current		$V_{PIN\ 3} = 1V$	1	2.5		mA
Output Source Current		$V_{PIN\ 3} = 4V$	-0.5	-1.3		mA
Output High Voltage		$I_{PIN\ 3} = -0.5mA$	4.0	4.7	5.0	V
Output Low Voltage		$I_{PIN\ 3} = 1mA$	0	0.5	1.0	V
Unity Gain Bandwidth			3	5.5		MHz
Slew Rate			6	12		V/ μ s
PWM COMPARATOR						
Pin 8 Bias Current		$V_{PIN\ 8} = 0V$		-1	-5	μ A
Duty Cycle Range			0		75	%
Pin 3 Zero DC Threshold			1.1	1.25		V
Delay to Output				50	80	ns
SOFT-START						
Charge Current (Pin 9)	ML4811	$V_{PIN\ 9} = 1V, V_{PIN\ 4, 12} = 0$	-35	-55	-75	μ A
Discharge Current (Pin 9)		$V_{PIN\ 9} = 3V, V_{PIN\ 4} > 2.5$	1	5		mA
		$V_{PIN\ 9} = 3V, V_{PIN\ 12} > 1.65, V_{PIN\ 4} < 2$	1	5		mA
Charge Current (Pin 20)		$V_{PIN\ 20} = 1V$	1	5		mA
Discharge Current (Pin 20)		Requires external discharge resistor		0		μ A
CURRENT LIMIT/SHUTDOWN						
Pin 12 Bias Current		$0V < V_{PIN\ 12} < 4V$			+15	μ A
Current Limit Threshold	ML4810		1.2	1.3	1.4	V
	ML4811		0.95	1.1	1.3	V
Reset Threshold (Pin 12)	ML4810	$V_{PIN\ 4} < 2V$	1.60	1.75	1.90	V
	ML4811	$V_{PIN\ 4} < 2V$	1.4	1.50	1.8	V
Delay to Output				40	70	ns
Pin 4 Charging Current		$V_{PIN\ 12} = 2V$	120	150	180	μ A
Restart Threshold (Pin 4)			2	2.45	3	V
OVP Shutdown Threshold (Pin 11)			2.4	2.7	2.8	V
OVP Input Current		$V_{PIN\ 11} = 3V$	40	50	60	μ A
Charge Current (Pin 8)	ML4810	$V_{PIN\ 8} = 1V, V_{PIN\ 4, 9} = 0$	-40	-50	-60	μ A
OUTPUT						
Output Low Level		$I_{OUT} = 20mA$		0.25	0.4	V
		$I_{OUT} = 200mA$		1.2	2.2	V
Output High Level		$I_{OUT} = -20mA$	13.0	13.5		V
		$I_{OUT} = -200mA$	12.0	13.0		V
Collector Leakage		$V_C = 30V$		100	500	μ A
Rise/Fall Time		$C_L = 1000pF$		30	60	ns
SUPPLY						
Start Up Current	ML4810	$V_{CC} = 8V$		2.0	3.5	mA
	ML4811	$V_{CC} = 8V$		2.5	4.0	mA
I_{CC}	ML4810	$V_{PIN\ 1, 7, 9} = 0V, V_{PIN\ 2} = 1V, T_A = 25^\circ C$		32	46	mA
	ML4811	$V_{PIN\ 1, 7, 9} = 0V, V_{PIN\ 2} = 1V, T_A = 25^\circ C$		38	55	mA

Note 1: Limits are guaranteed by 100% testing, sampling, or correlation with worst-case test conditions.

FUNCTIONAL DESCRIPTION

SOFT START AND CURRENT LIMIT

The ML4810/11 offers a unique system of fault detection and reset. Most PWM controllers use a two threshold method which relies on the buildup of current in the output inductor during a fault. This buildup occurs because:

1. Inductor di/dt is a small number when the switch is off under load fault (short circuit) conditions, since VL is small.
2. Some energy is delivered to the inductor since the IC must first detect the over-current because there is a finite delay before the output switch can turn off.

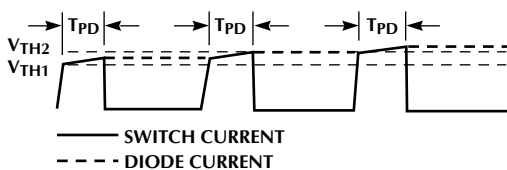

Figure 1. Current Waveforms for Slow Turn-Off System with Load Fault

This scheme was adequate for controllers with longer comparator propagation delays and turn-off delays than is desirable in a high frequency system. For systems with low propagation delays, very little energy will be delivered to the inductor and the current “ratcheting” described above will not occur. This results in the controller never detecting the load fault and continuing to pump full current to the load indefinitely, causing heating in the output rectifiers and inductor.

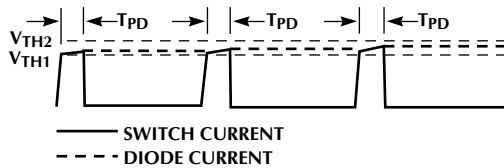

Figure 2. Current Waveforms for High Speed System with Load Fault

A method of circumventing this problem involves “counting” the number of times the controller terminates the PWM cycle due to the cycle by cycle current limit.

When the switch current crosses the 1.1V threshold A1 signals the F1 to terminate the cycle and sets F3, which is reset at the beginning of the PWM cycle. The output of F3 turns on a current source to charge C2. When, after several cycles, C2 has charged to 2.45V, A5 turns on F2 to discharge soft start capacitor C1. Charge is short lived (for instance a disk drive start-up or a board being plugged into a live rack) the control can “ride out” the surge with the switch protected by the cycle by cycle limit. R1 and C1 can be selected to track diode heating, or to ride out various system surge requirements as required.

If the high current demand is caused by a short circuit, the duty cycle will be short and the output diodes will carry the current for the majority of PWM cycle. C2 charges fastest for low duty cycles (since F3 will be on for a longer time) providing for quicker shutdown during short-circuit when the output diodes are being maximally stressed.

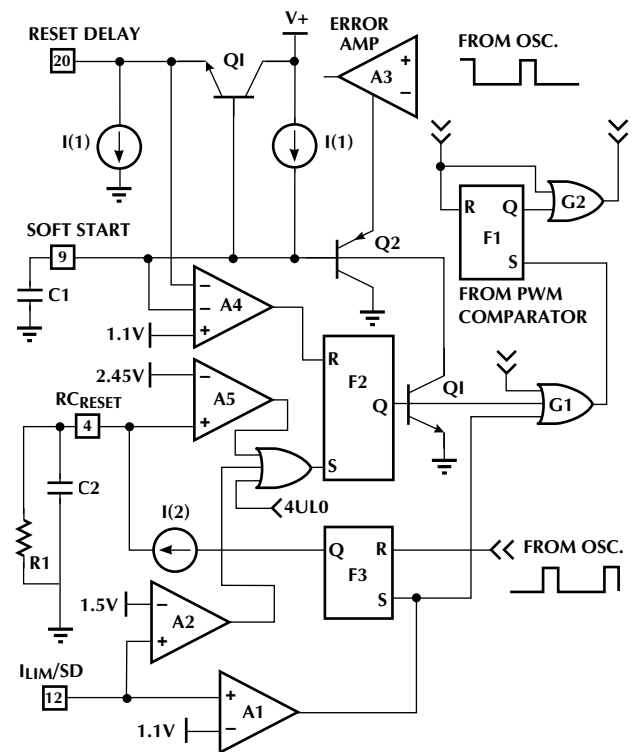

Figure 3. Integrating Soft Start Reset

ML4810, ML4811

OSCILLATOR

The ML4811 oscillator charges the external capacitor (C_T) with a current (I_{SET}) equal to $3/R_T$. When the capacitor voltage reaches the upper threshold (Ramp Peak), the comparator changes state and the capacitor discharges to the lower threshold (Ramp Valley) through Q1. While the capacitor is discharging, Q2 provides a high pulse. A discharge of the oscillator can be initiated by applying a high level to the Sync pin. A short pulse of a frequency higher than the oscillator's free running frequency can be used to synchronize the ML4811 to an external clock. The pulse can be equal to the desired deadtime (T_D) or the deadtime can be determined by I_{DIS} and C_T , whichever is greater.

The oscillator period can be described by the following relationship:

$$t_{OSC} = t_{RAMP} + t_{DEADTIME}$$

where:

$$t_{RAMP} = \frac{C (Ramp Valley to Peak)}{I_{SET}}$$

and:

$$t_{DEADTIME} = \frac{C (Ramp Valley to Peak)}{I_{Q1}}$$

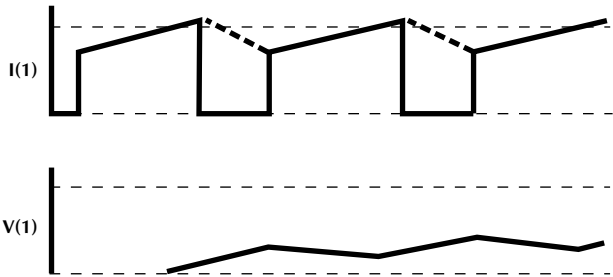

Figure 4. Switching Current and Pin 4 Voltage — Normal

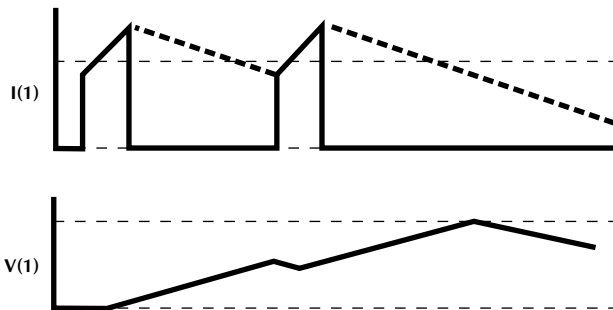

Figure 5. Switching Current and Pin 4 Voltage — Load Fault

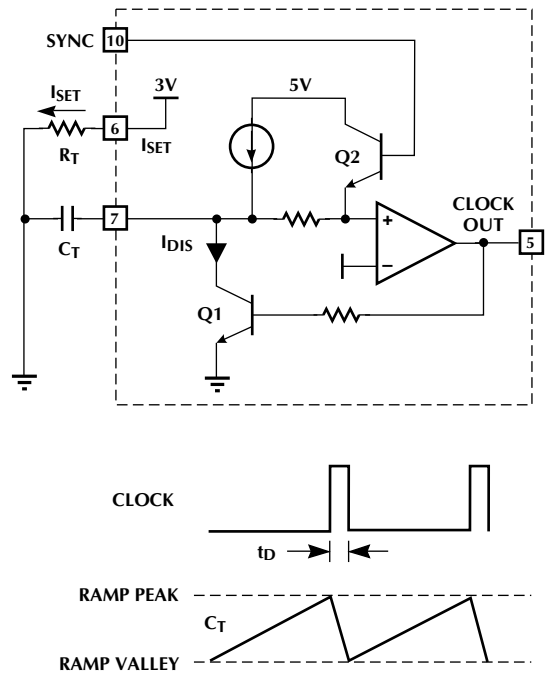

Figure 6. Simplified Oscillator Block Diagram and Timing

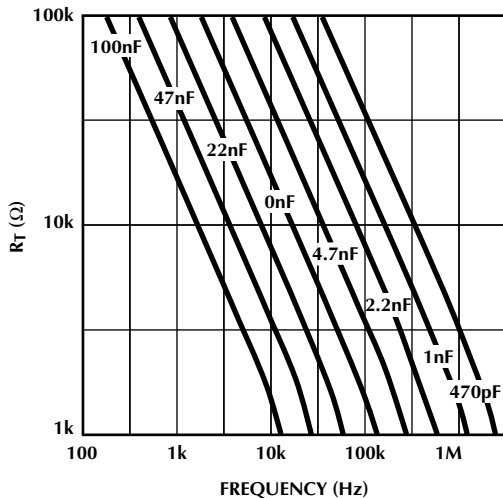

Figure 7. Oscillator Timing Resistance vs Frequency

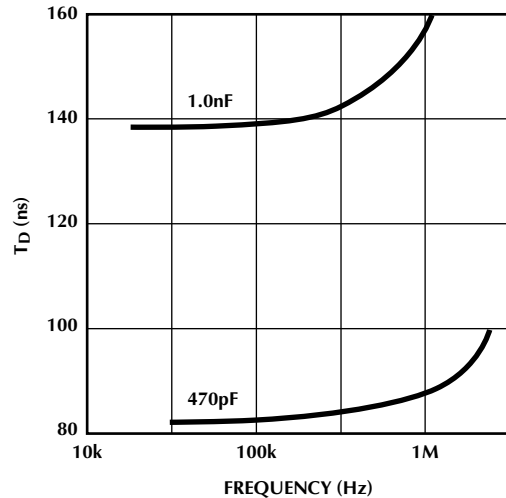

Figure 8. Oscillator Deadtime vs Frequency

ERROR AMPLIFIER

The ML4811 error amplifier is a 5.5MHz bandwidth 12V/μsec slew rate op-amp with provision for limiting the positive output voltage swing (Output Inhibit line) for ease in implementing the soft start function.

OUTPUT DRIVER STAGE

The ML4811 Output Driver is a 2A peak output high speed totem pole circuit designed to quickly switch the gates of capacitive loads, such as power MOSFET transistors.

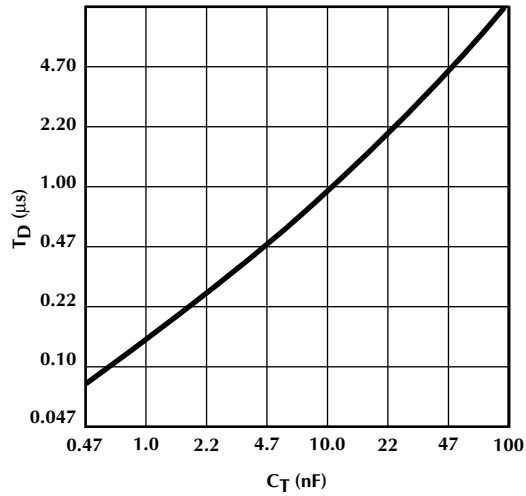

Figure 9. Oscillator Deadtime vs C_T ($3k\Omega \leq R_T \leq 100k\Omega$)

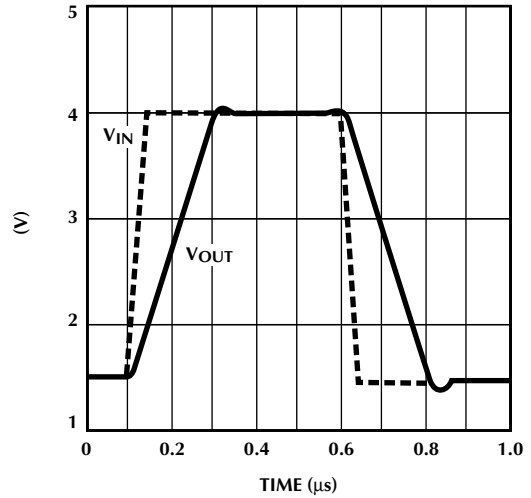

Figure 10. Unity Gain Slew Rate

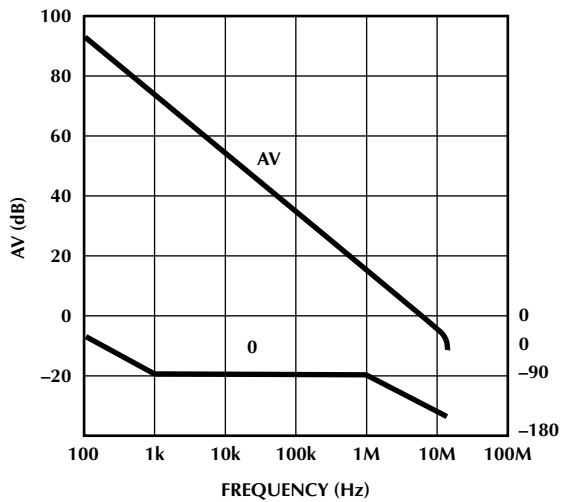

Figure 11. Open Loop Frequency Response

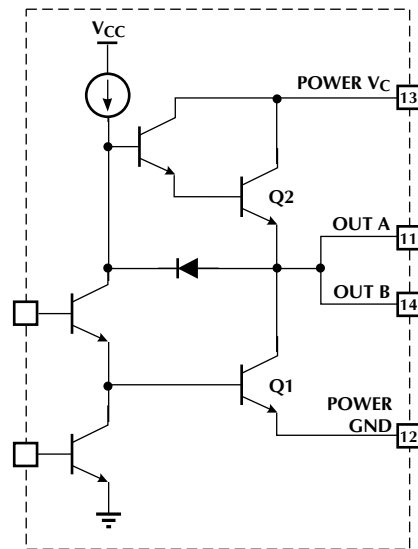

Figure 12. Simplified Schematic

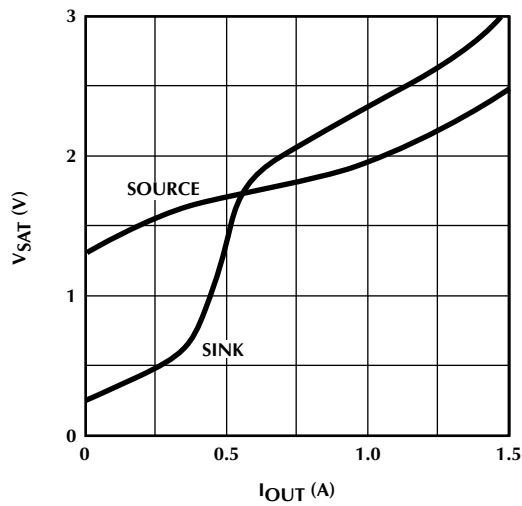

Figure 13. Saturation Curves

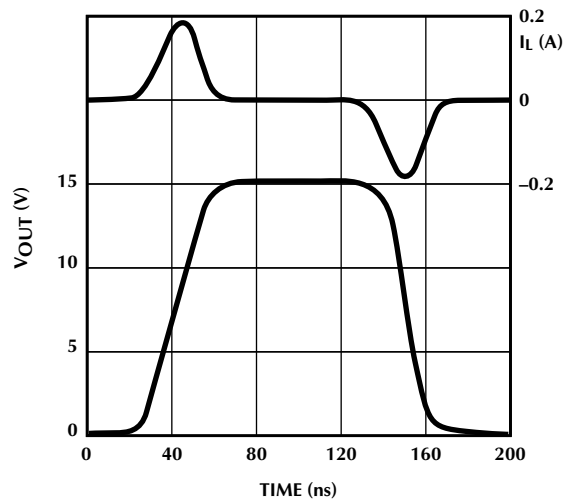

Figure 14. Rise/Fall Time ($C_L = 1000\text{pF}$)

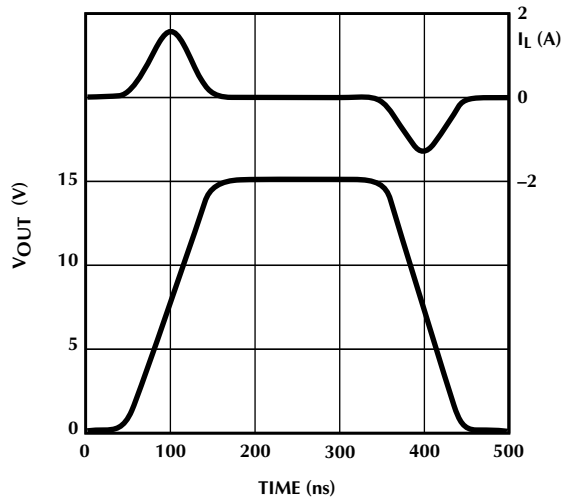

Figure 15. Rise/Fall Time ($C_L = 10,000\text{pF}$)

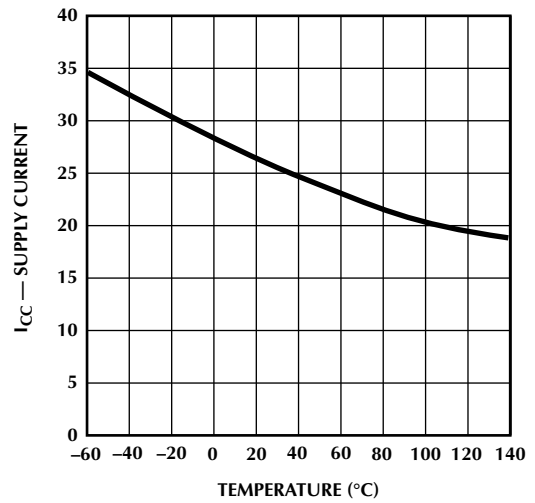
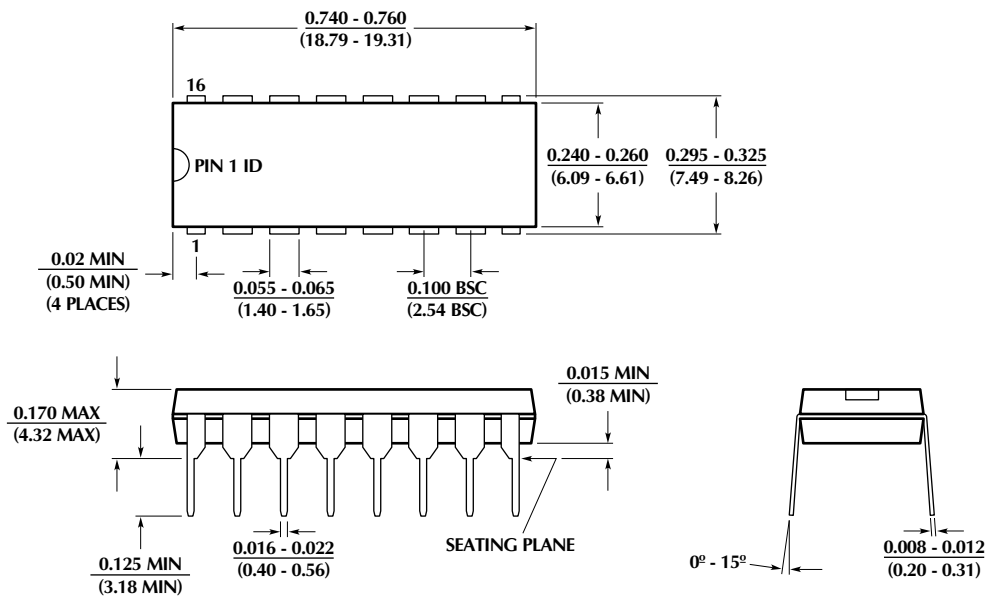

Figure 16. Supply Current vs. Temperature

ML4810, ML4811

PHYSICAL DIMENSIONS inches (millimeters)

Package: P16
16-Pin PDIP



Package: S16W
16-Pin Wide SOIC

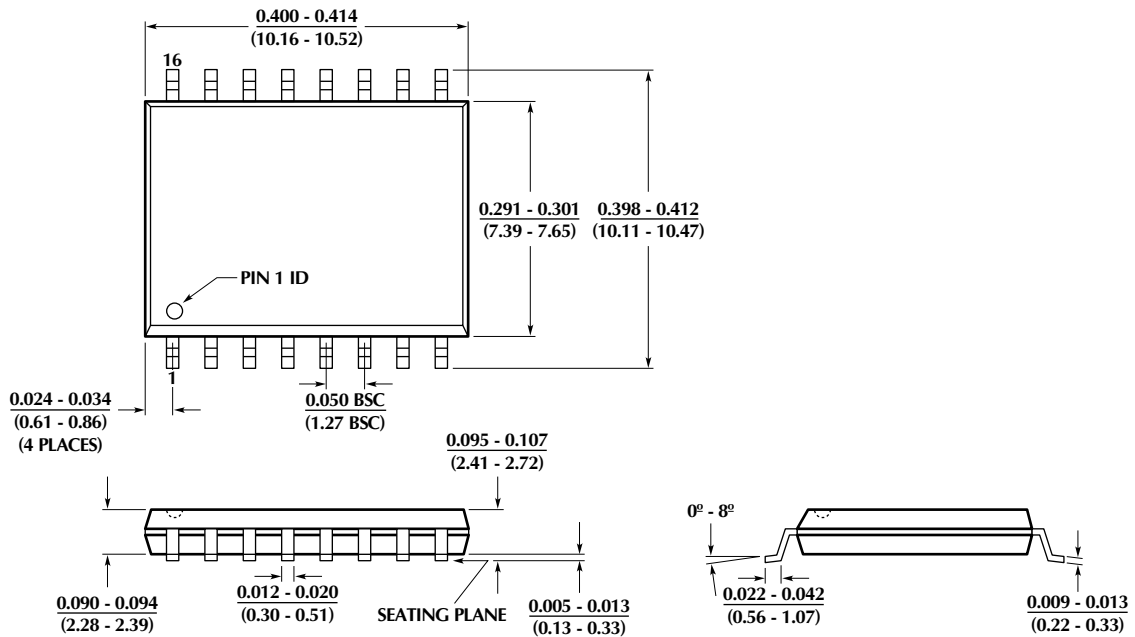

PHYSICAL DIMENSIONS inches (millimeters) (Continued)

Package: P20
20-Pin PDIP

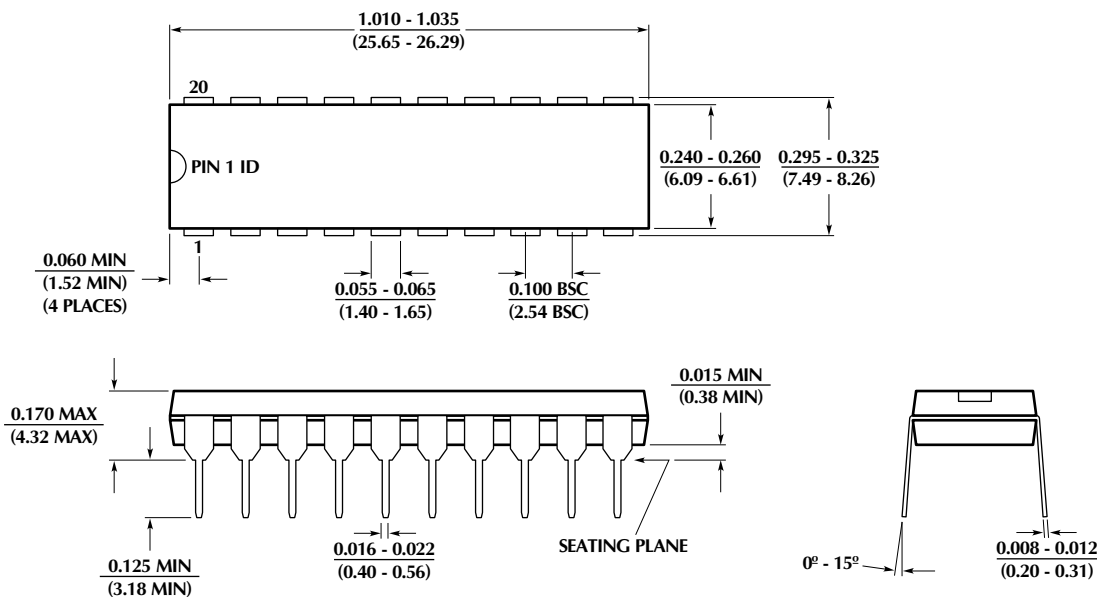

Package: S20
20-Pin SOIC

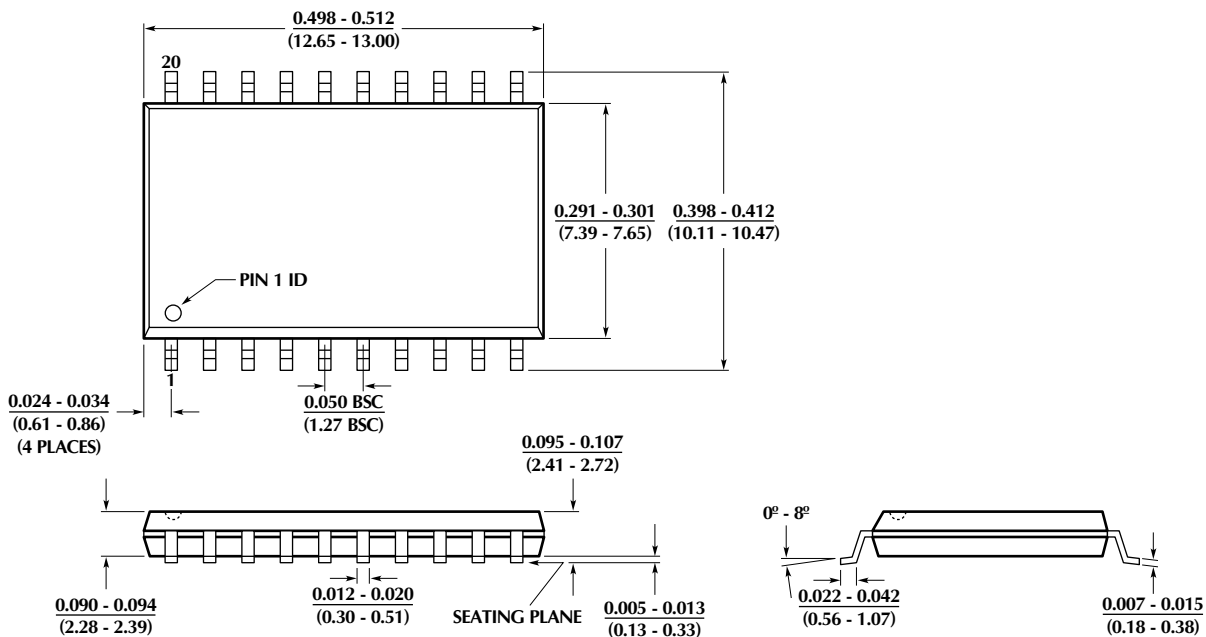

ORDERING INFORMATION

PART NUMBER	TEMPERATURE RANGE	PACKAGE
ML4810CP	0°C to 70°C	16-Pin PDIP (P16) (End Of Life)
ML4810CS	0°C to 70°C	16-Pin Wide SOIC (S16W) (Obsolete)
ML4811CP	0°C to 70°C	20-Pin PDIP (P20) (Obsolete)
ML4811CS	0°C to 70°C	20-Pin SOIC (S20)(Obsolete)

© Micro Linear 1997.  **Micro Linear** is a registered trademark of Micro Linear Corporation. Products described in this document may be covered by one or more of the following patents, U.S.: 4,897,611; 4,964,026; 5,027,116; 5,281,862; 5,283,483; 5,418,502; 5,508,570; 5,510,727; 5,523,940; 5,546,017; 5,559,470; 5,565,761; 5,592,128; 5,594,376; Japan: 2598946; 2619299. Other patents are pending.

Micro Linear reserves the right to make changes to any product herein to improve reliability, function or design. Micro Linear does not assume any liability arising out of the application or use of any product described herein, neither does it convey any license under its patent right nor the rights of others. The circuits contained in this data sheet are offered as possible applications only. Micro Linear makes no warranties or representations as to whether the illustrated circuits infringe any intellectual property rights of others, and will accept no responsibility or liability for use of any application herein. The customer is urged to consult with appropriate legal counsel before deciding on a particular application.

2092 Concourse Drive
San Jose, CA 95131
Tel: 408/433-5200
Fax: 408/432-0295