

Features

- On Chip Hall Sensor
- Rotor-Locked Shutdown
- Automatically Restart
- Rotor-State Detection (RD) Output
- Built-in Zener Protection for Output Driver
- Operating Voltage: 3.8V~28V
- Output Current: $I_{O(AVE)} = 400mA$
- Lead Free Finish/RoHS Compliant for Lead Free products (Note 1)
- Lead Free Packages: SIP-5L and SOT89-5L

General Description

AH289 is a monolithic fan motor controller with Hall sensor's capability. It contains two complementary open-drain transistors for motors coil driving, an automatic lock current shutdown, and recovery protection. In addition, the Rotor-State Detection (RD) output is for Rotor-State Detection.

Rotor-lock shutdown detection circuit turns off the output driver when the rotor is blocked to avoid coil overheat. Then, the automatic recovery circuit will restart the motor. These protected actions are repeated and periodic during the blocked period. Until the blocking is removed, the motor recovers and runs normally.

Ordering Information

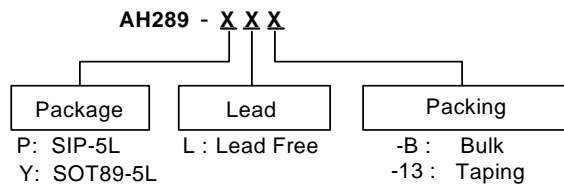

Note: 1. RoHS revision 13.2.2003. Glass and High Temperature Solder Exemptions Applied, see *EU Directive Annex Notes 5 and 7*.

Device	Package Code	Packaging	Tube/Bulk		7" Tape and Reel	
			Quantity	Part Number Suffix	Quantity	Part Number Suffix
AH289-P	P	SIP-5	1000	-B	NA	NA
AH289-Y	Y	SOT89-5	NA	NA	2500/Tape & Reel	-13

Note: 2. Pad layout as shown on Diodes Inc. suggested pad layout document AP02001, which can be found on our website at <http://www.diodes.com/datasheets/ap02001.pdf>.

Pin Assignment

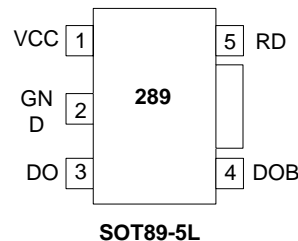
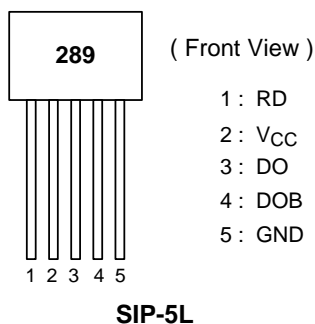

Pin Descriptions

Symbol	Description
RD	Rotor-State Detection
V _{dd}	Input Power
DO	Output Pin
DOB	Output Pin
GND	Ground

Block Diagram

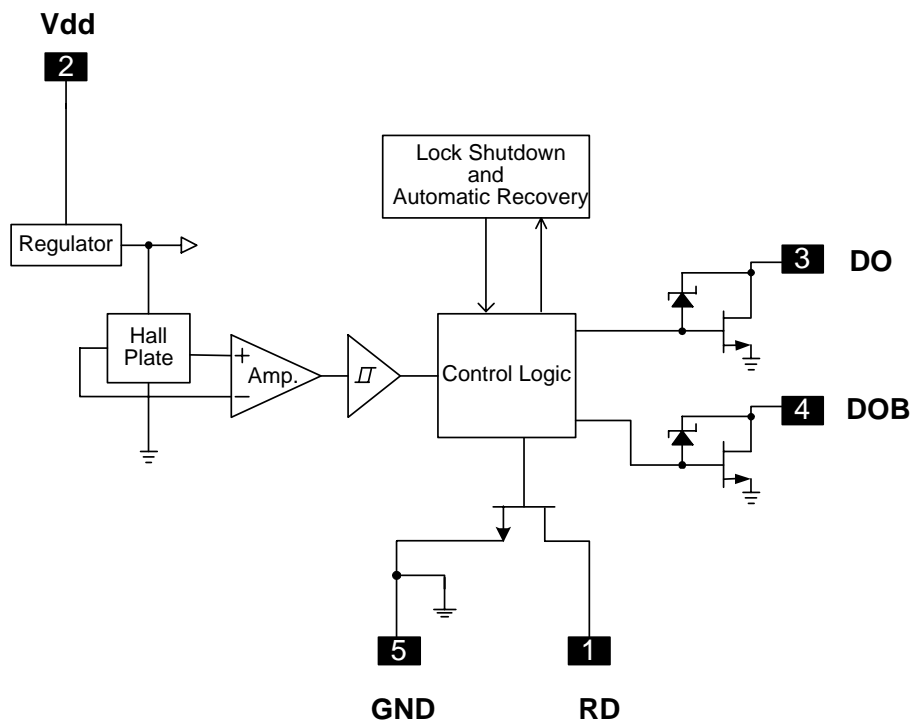

Typical Application Circuit

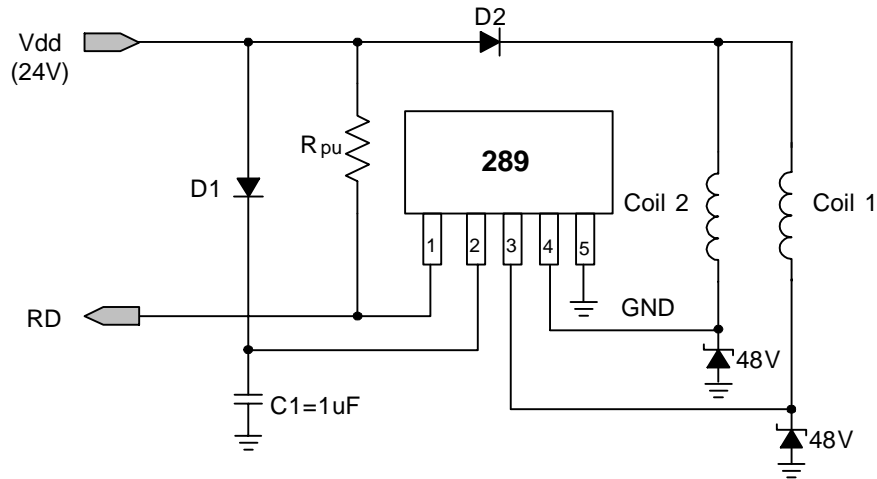

24V DC Brush-Less Fan with RD Output Function

Absolute Maximum Ratings (T_A = 25°C)

Characteristics	Symbol	Rating	Unit	
Supply Voltage	V _{CC}	30	V	
Output Current	I _{O(AVE)}	SIP5/SOT89-5	mA	
	I _{O(PEAK)}			700
Power Dissipation	P _D	SIP5	550	mW
		SOT89-5	800	
Operating Temperature	T _{opr}	-40 ~ 100	°C	
Storage Temperature	T _{stg}	-55 ~ 150	°C	
Maximum Junction Temperature	T _j	150	°C	
Thermal Resistance	θ _{JA}	SIP5	227	°C/W
		SOT89-5	156	°C/W

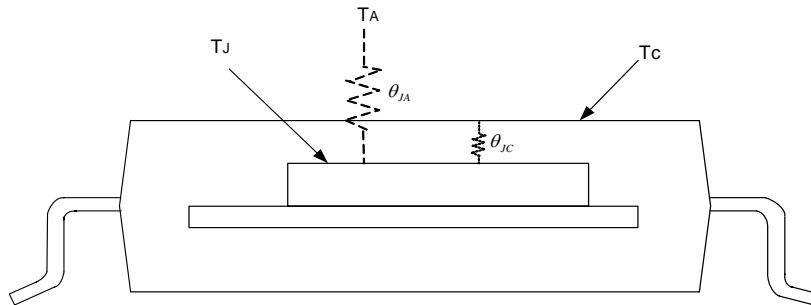

Note: θ_{JA} should be confirmed with what heat sink thermal resistance. If no heat sink contacting, θ_{JA} is almost the same as θ_{JC}.

Electrical Characteristics ($T_A = 25\text{ }^\circ\text{C}$, $V_{dd} = 24\text{V}$, unless otherwise specified)

Characteristics	Symbol	Conditions	Min.	Typ.	Max.	Unit
Supply Voltage	V_{dd}	Operating	3.8	-	28*	V
Supply Current	I_{CC}	Operating	-	2.0	4.0	mA
Output Leakage Current	I_{off}	$V_{OUT} = 24\text{V}$	-	< 0.1	10	μA
Locked Protection On	T_{Irp-on}		0.4	0.46	0.6	Sec
Locked Protection Off	$T_{Irp-off}$		2.4	2.76	3.6	Sec
Output Saturation Voltage	$V_{OUT(SAT)}$	$I_O = 200\text{mA}$	-	450	700	mV
		$I_O = 300\text{mA}$	-	680	800	
Output On Resistance	$R_{ds(on)}$	$I_O = 200\text{mA}$	-	2.25	3.5	ohm
RD Output Vds	V_{ol}	$I_O = 10\text{mA}$	-	0.3	0.5	V
Output Zener-Breakdown Voltage	V_Z		42	55	65	V

*Note: Please watch the current limit issue when the operation voltage is over 26.4V, because of the different efficiency in the coil.

Truth Table

IN-	IN+	CT	OUT1	OUT2	RD	Mode
H	L	L	H	L	L	Rotating
L	H	L	L	H	L	Rotating
-	-	H	off	off	H	Lockup protection activated

Magnetic Characteristics ($T_A = 25\text{ }^\circ\text{C}$, $V_{dd} = 24\text{V}$, unless otherwise specified)

(1mT = 10 Gauss)

Characteristics	Symbol	Min.	Typ.	Max.	Unit
Operation Point	Bop	10	30	60	Gauss
Release Point	Brp	-60	-30	-10	Gauss
Hysteresis	Bhy	--	60	--	Gauss

Operating Characteristics

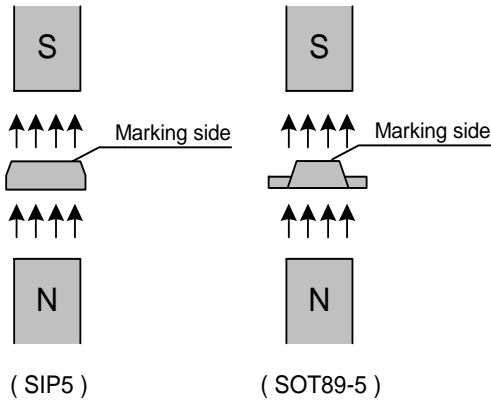
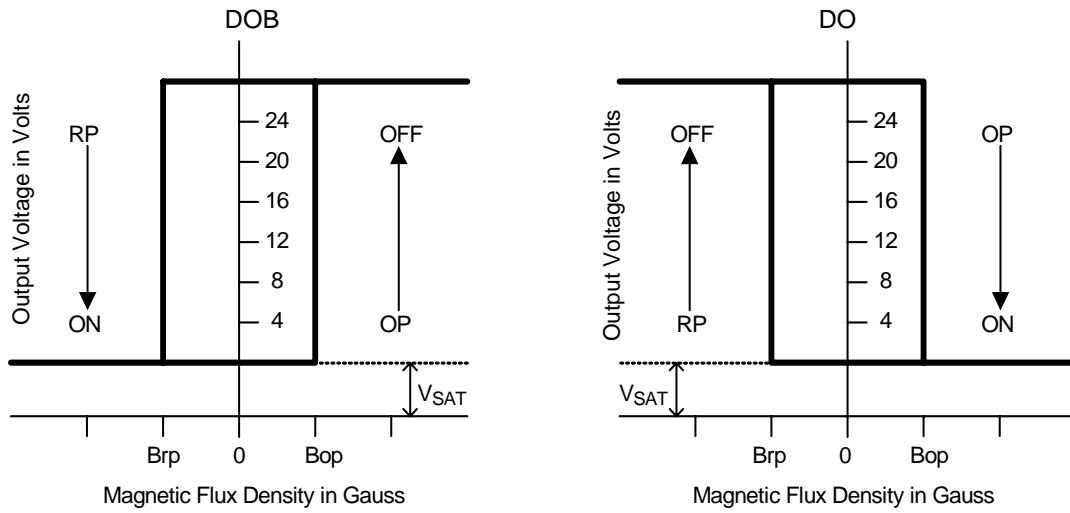

Performance Characteristics (SIP-5L)

T_A (°C)	25	50	60	70	80	85	90	95	100
P _D (mW)	550	440	396	352	308	286	264	242	220
T_A (°C)	105	110	115	120	125	130	135	140	150
P _D (mW)	198	176	154	132	110	88	66	44	0

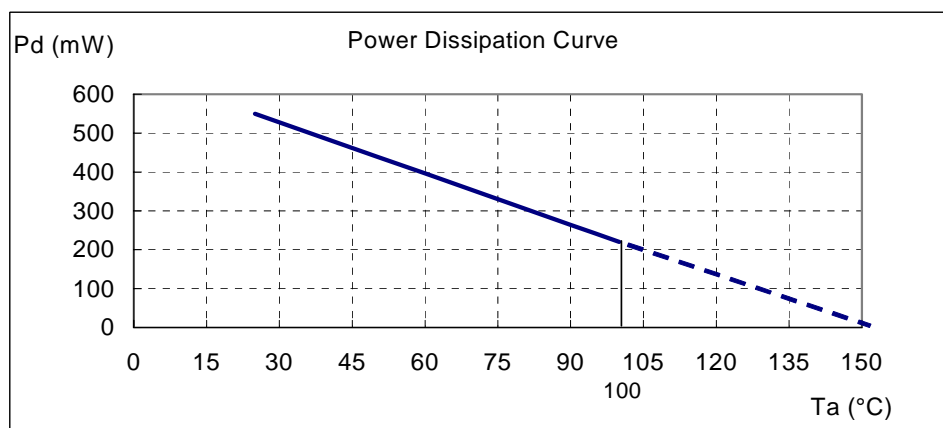

Performance Characteristics (SOT89-5L)

T_A (°C)	25	50	60	70	75	80	85	90	95	100
P _D (mW)	800	640	576	512	480	448	416	384	352	320
T_A (°C)	105	110	115	120	125	130	135	140	145	150
P _D (mW)	288	256	224	192	160	128	96	64	32	0

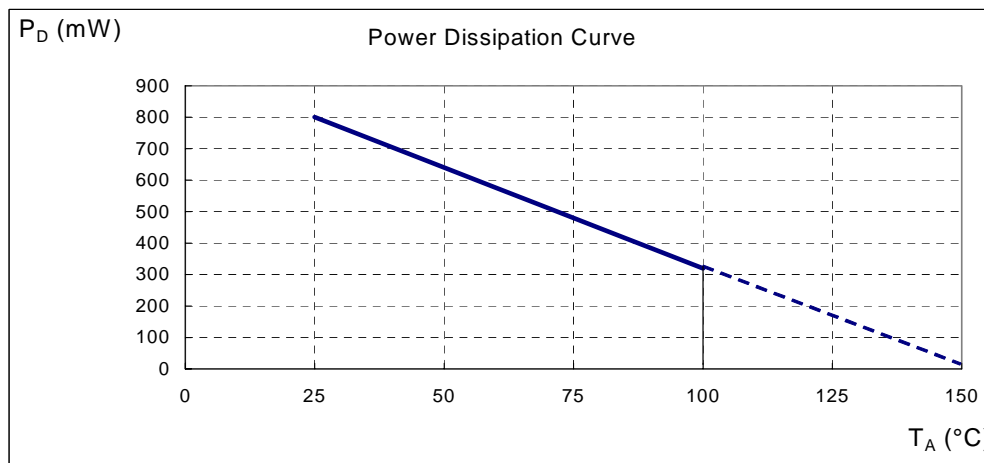

Marking Information

(1) SIP-5L

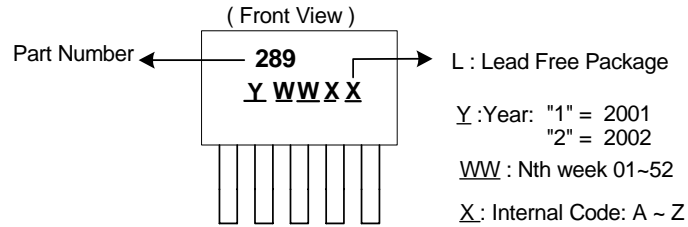

(2) SOT89-5L

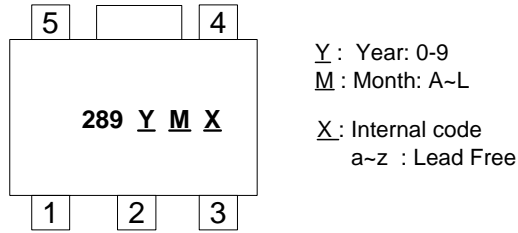

Package Information (unit: mm)

(1) Package type: SIP-5L

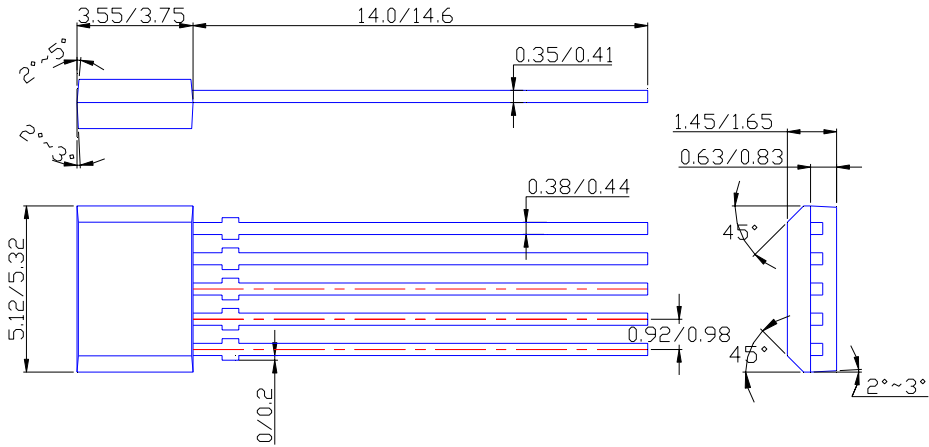

Location of Sensing Point

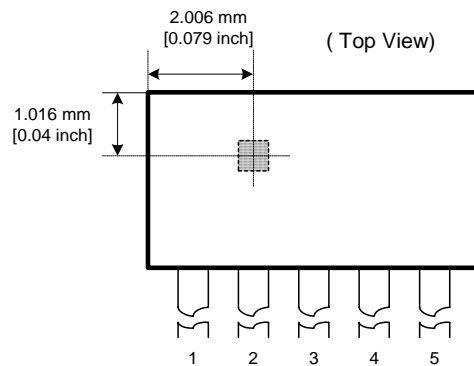

Package Information (Continued)

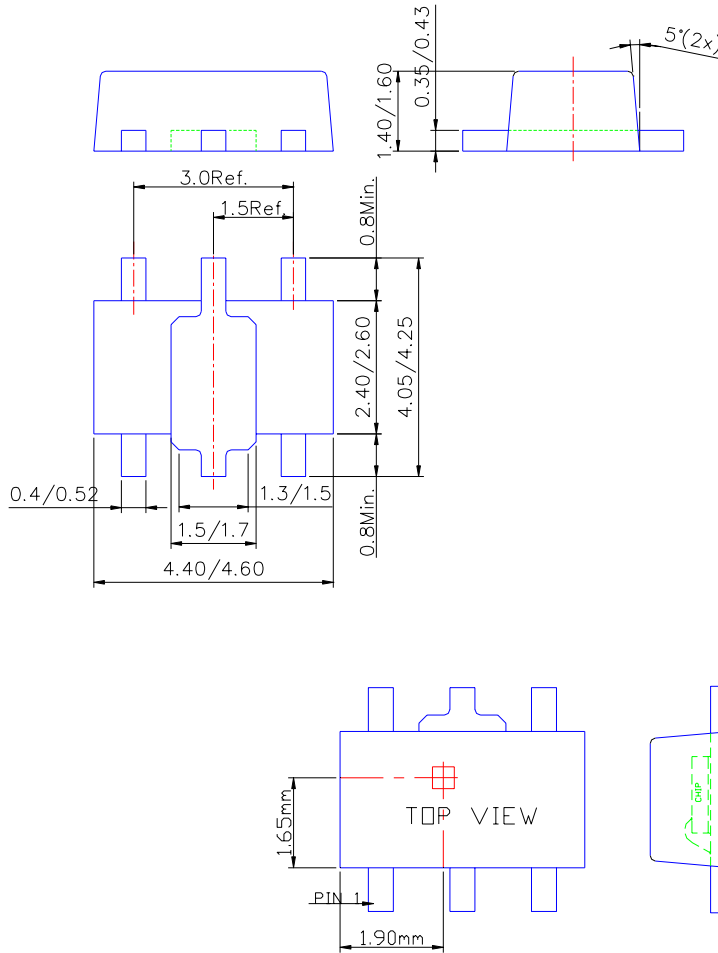

Sensor Location

IMPORTANT NOTICE

Diodes Incorporated and its subsidiaries reserve the right to make modifications, enhancements, improvements, corrections or other changes without further notice to any product herein. Diodes Incorporated does not assume any liability arising out of the application or use of any product described herein; neither does it convey any license under its patent rights, nor the rights of others. The user of products in such applications shall assume all risks of such use and will agree to hold Diodes Incorporated and all the companies whose products are represented on our website, harmless against all damages.

LIFE SUPPORT

Diodes Incorporated products are not authorized for use as critical components in life support devices or systems without the expressed written approval of the President of Diodes Incorporated.