Features

- Interval Pause: 4s to 20s
- After-wiping Time: 2s to 20s
- Wiper Motor's Park Switch
- 0.6s Prewash Delay
- Wipe/Wash Mode Priority
- One External Capacitor Determines All Time Sequences
- Relay Driver with Z-diode
- Interference Protection According to VDE 0839 or ISO/TR 7637/1
- Load-dump Protected



1. Description

The U641B is a bi-polar integrated circuit designed for the wiper application in the automotive market. It includes wipe, wash and interval mode.

2. Functional Description

As a convenience feature of the windshield wiper, intermittent and wipe/wash operation functions are implemented in most of the automobiles. The U641B is a cost-effective solution for an accurate timing function control. Wipe/wash mode has priority over interval mode. Interval pause and after-wiping time can be set to fixed values by using resistors in a broad time range. Added value can be provided with an individual, continuous adjustment of the interval pause by a potentiometer which may be built into the stalk. For proper operation, it is mandatory to feed the signal of the wiper motor's park switch into the U641B.



Interval and Wipe/Wash Wiper Control IC with Delay

U641B

Rev. 4773B-AUTO-09/05



Figure 2-1. Block Diagram

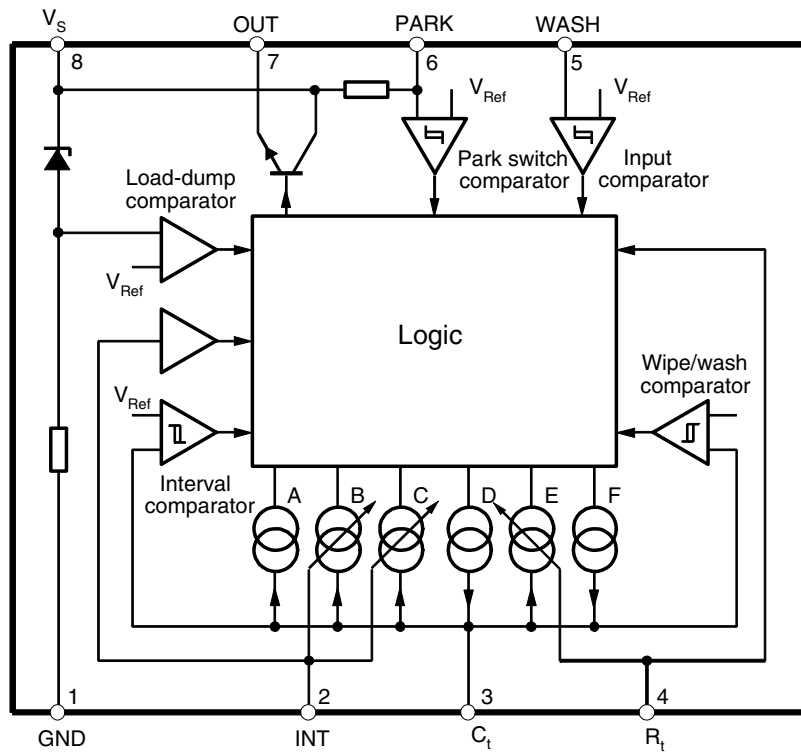

3. Pin Configuration

Figure 3-1. Pinning

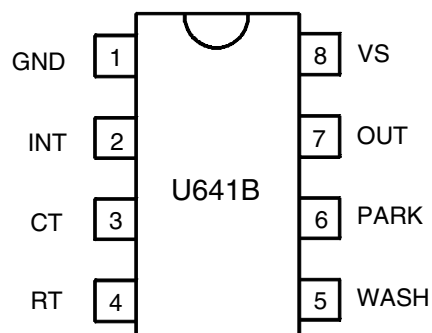

Table 3-1. Pin Description

Pin	Symbol	Function
1	GND	Ground
2	INT	Interval switch
3	CT	Timing capacitor C_2
4	RT	After-wiping time resistance
5	WASH	Wipe/wash switch
6	PARK	Park switch for wiper motor
7	OUT	Relay control output
8	VS	Supply voltage terminal 15

4. Circuit Description

4.1 Interval Function, Pin 2

By closing the interval switch, S_2 , to supply voltage, V_{Batt} , the relay is activated. The internal current source (pin 3) which holds the capacitor C_2 in charged state is switched-off. As soon as there is a positive potential at the park switch (S_1), current source F (see [Figure 2-1 on page 2](#)) charges the capacitor C_2 very quickly. After the wiper operation is finished, S_1 is again at ground potential, the relay is in the off position - interval pause begins - the capacitor C_2 is discharged through the current source C, till the voltage at pin 3 is below the threshold of 2V. Interval pause can be adjusted between 4 s to 20 s with the help of potentiometer R_3 . Now the relay switches on and the next interval cycle begins. Opening switch S_2 causes current source A to discharge C_2 immediately and current sources C and F are switched off.

4.2 Wipe/Wash (WIWA) Operation, Pin 5

By closing the WIWA switch, S_3 , to supply voltage, V_{Batt} , the water pump starts spraying the water on the windshield. During this function, the current source A is switched-off which keeps the capacitor C_2 in a discharged state. Now the capacitor is charged through the current source F. If (after a time interval of approximately 600 ms) the voltage at the capacitor is greater than 6.1V, the relay is turned on as long as the switch WIWA is closed.

The after-wiping time begins when the switch is open, the sources D and F are switched off and the source E is activated. Source E discharges the capacitor until the voltage is less than 2.2V. The relay is off and the wiper-motor is supplied via the park switch until the park position is reached. The after-wiping time is determined by the current source E which can be regulated with the external resistor R_{Time} . When the after-wiping time has elapsed, the source A discharges the capacitor. The relay switch is independent of the park switch S_1 .

4.3 Interval and WIWA Functions

The interval function is interrupted immediately when the switch S_2 is activated. The current source A discharges the capacitor to a value of 2V, afterwards, the normal wash function starts.

Interval wiping starts immediately when the after-wipe time is over. The switching delays are slightly shorter, because the capacitor is already charged to a value of 2V.

The Wipe/Wash function is not interrupted when the interval switch S_2 is activated. The interval function begins after the WIWA function has elapsed.

Figure 4-1. Application Circuit with Interval and Wipe/Wash Operation

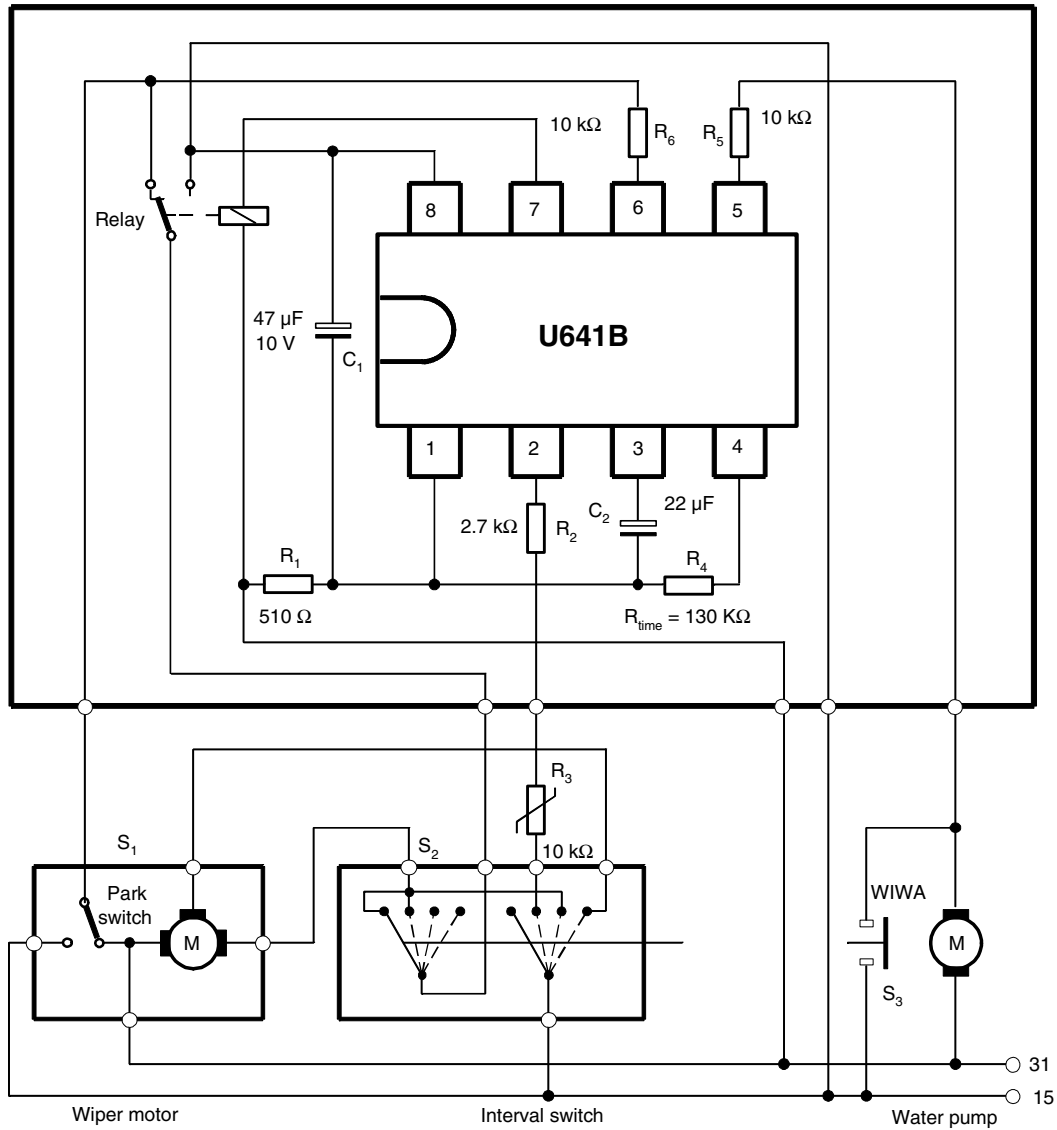

5. Absolute Maximum Ratings

Stresses beyond those listed under “Absolute Maximum Ratings” may cause permanent damage to the device. This is a stress rating only and functional operation of the device at these or any other conditions beyond those indicated in the operational sections of this specification is not implied. Exposure to absolute maximum rating conditions for extended periods may affect device reliability.

Parameters	Pin	Symbol	Value	Unit
Supply voltage $t = 60s$, terminal 15	8	V_{Batt}	28	V
Supply current $t = 2 ms$	8	I_8	1.5	A
$t = 200 ms$		I_8	150	mA
Relay control output current (DC) $t = 200 ms$	7	I_7	200	mA
		I_7	1.2	A
Pulse Current (Control Inputs) $t = 200 ms$				
Park switch, S_1	6	I_6	50	mA
Wipe/Wash switch, S_3	5	I_5	50	
Interval switch, S_2	2	I_2	50	
Power dissipation $T_{amb} = 90^\circ C$		P_{tot}	500	mW
Storage temperature range		T_{stg}	-55 to +125	$^\circ C$
Ambient temperature range		T_{amb}	-40 to +85	$^\circ C$

6. Thermal Resistance

Parameters		Symbol	Value	Unit
Junction ambient	DIP8	R_{thJA}	120	K/W
	SO8	R_{thJA}	160	K/W

7. Electrical Characteristics

$V_{\text{Batt}} = 12\text{V}$, $T_{\text{amb}} = 25^\circ\text{C}$, reference point is pin 8 (see Figure 4-1 on page 5) unless otherwise specified.

Parameters	Test Conditions	Pin	Symbol	Min.	Typ.	Max.	Unit
Supply voltage		8	V_{Batt}	9		16.5	V
Supply current			I_8		10		mA
Z-diode limitation			V_1		7.6		V
Overvoltage							
Threshold current			I_1		-50		mA
Threshold voltage			V_{Batt}		35		V
Relay Control Output		7					
Saturation voltage	$I_7 = 100\text{ mA}$ $I_7 = 200\text{ mA}$		V_7			-1.0 -1.5	V
Leakage current			I_7		100		μA
Park Switch		6					
Internal pull-up resistance	$R_6 = 10\text{ k}\Omega$		R_6		50		$\text{k}\Omega$
Switching threshold voltage			V_6		-3.3		V
Protection diode	$I_6 = -10\text{ mA}$ $I_6 = 10\text{ mA}$		V_6		-0.8		V
			V_6		7.6		V
Input C_t		3					
Internal resistance			R_3		100		Ω
Interval Input		$R_2 = 2.7\text{ to }30\text{ k}\Omega$	2				
Protection diode	$I_2 = -10\text{ mA}$ $I_2 = 30\text{ mA}/10\text{ ms}$		V_2		-0.8 7.6		V
WASH Input		$R_5 = 10\text{ k}\Omega$	5				
Switching threshold/ Hysteresis			V_5		-1.4/ -5.4		V
Protection diode	$I_5 = -10\text{ mA}$ $I_5 = 10\text{ mA}$		V		-0.8 7.6		V
Switching Characteristics		$R_4 = 47\text{ k}\Omega\text{ to }300\text{ k}\Omega$, $I_4 = -150\text{ }\mu\text{A}$					
Interval time	$R_3 = 0\text{ k}\Omega$ $R_3 = 10\text{ k}\Omega$		t_2	3.6 10.8	4 12	4.4 13.2	s
Prewash delay			t_{del}		600		ms
After-wipe-time	$R_4 = 130\text{ k}\Omega$	5	t_5	4.75	5.25	5.75	s

8. Diagrams

Figure 8-1. Interval Pause = $f(T)$; $C_t = 22 \mu\text{F}$

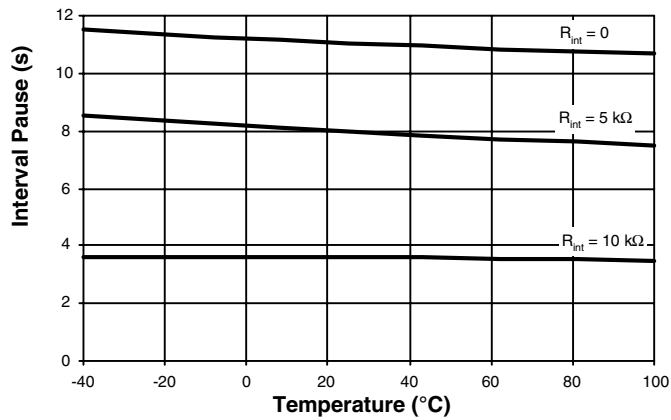

Figure 8-2. After-wiping Time = $f(T)$; $C_t = 22 \mu\text{F}$; $V_{\text{Batt}} = 8 \text{ V}$

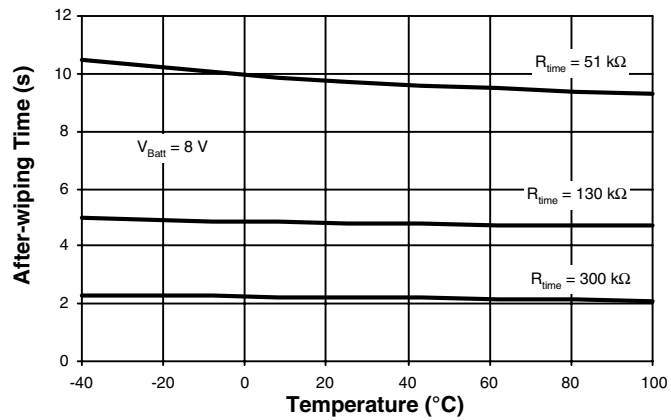

Figure 8-3. Prewash Time = $f(T)$; $C_t = 22 \mu\text{F}$

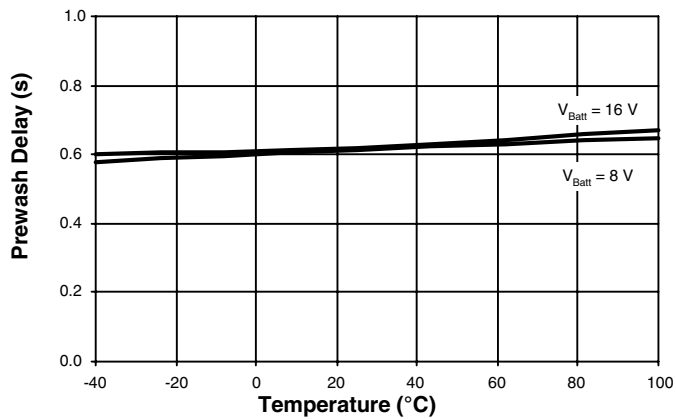

Figure 8-4. Interval Pause = f (R_{INT}); $C_t = 22 \mu\text{F}$

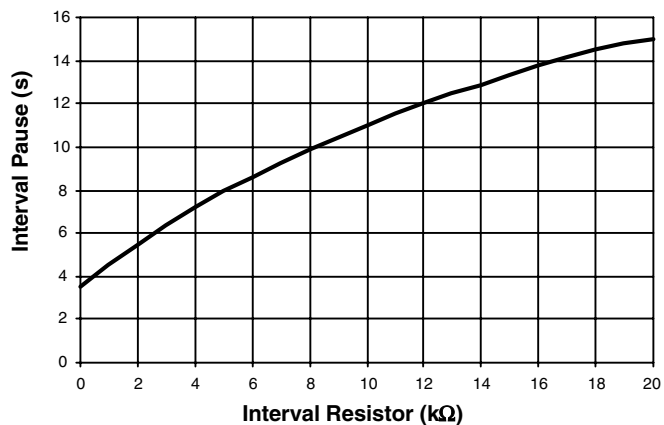
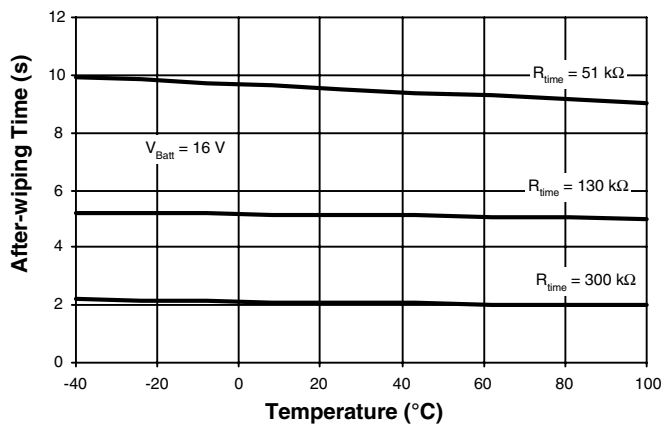

Figure 8-5. After-wiping Time = f (T); $C_t = 22 \mu\text{F}$; $V_{Batt} = 16 \text{ V}$



9. Ordering Information

Extended Type Number	Package	Remarks
U641B-MY	DIP8	Pb-free
U641B-MFPY	SO8	Tubed, Pb-free
U641B-MFPG3Y	SO8	Taped and reeled, Pb-free

10. Package Information

Package: DIP8
Dimensions in mm

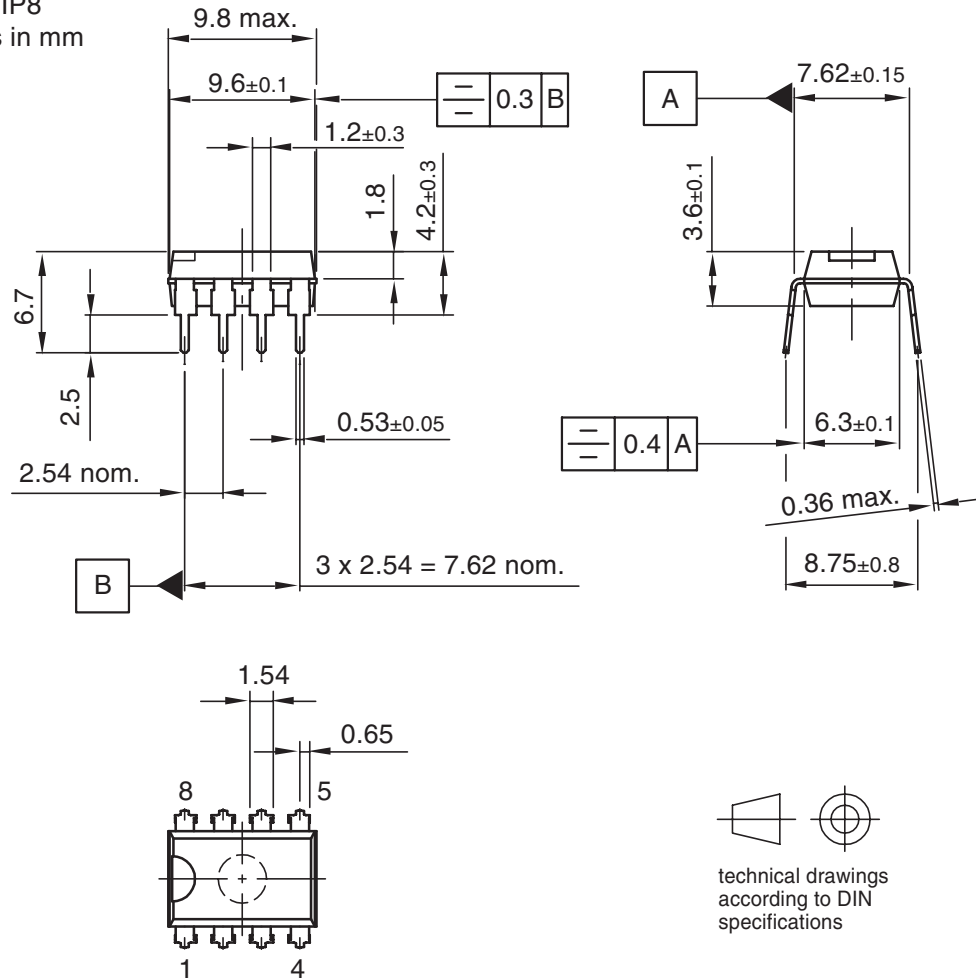

Drawing-No.: 6.543-5040.01-4

Issue: 1; 16.01.02

Package SO8

Dimensions in mm

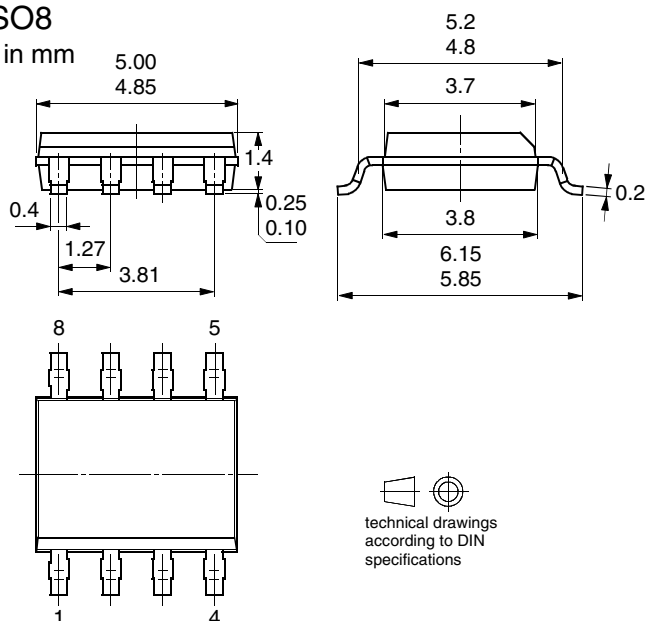

11. Revision History

Please note that the following page numbers referred to in this section refer to the specific revision mentioned, not to this document.

Revision No.	History
4773B-AUTO-09/05	<ul style="list-style-type: none"> • Put datasheet in a new template • Pb-free logo on page 1 added • Ordering Information on page 10 changed



Atmel Corporation

2325 Orchard Parkway
San Jose, CA 95131, USA
Tel: 1(408) 441-0311
Fax: 1(408) 487-2600

Regional Headquarters

Europe

Atmel Sarl
Route des Arsenaux 41
Case Postale 80
CH-1705 Fribourg
Switzerland
Tel: (41) 26-426-5555
Fax: (41) 26-426-5500

Asia

Room 1219
Chinachem Golden Plaza
77 Mody Road Tsimshatsui
East Kowloon
Hong Kong
Tel: (852) 2721-9778
Fax: (852) 2722-1369

Japan

9F, Tonetsu Shinkawa Bldg.
1-24-8 Shinkawa
Chuo-ku, Tokyo 104-0033
Japan
Tel: (81) 3-3523-3551
Fax: (81) 3-3523-7581

Atmel Operations

Memory

2325 Orchard Parkway
San Jose, CA 95131, USA
Tel: 1(408) 441-0311
Fax: 1(408) 436-4314

Microcontrollers

2325 Orchard Parkway
San Jose, CA 95131, USA
Tel: 1(408) 441-0311
Fax: 1(408) 436-4314

La Chantrerie
BP 70602
44306 Nantes Cedex 3, France
Tel: (33) 2-40-18-18-18
Fax: (33) 2-40-18-19-60

ASIC/ASSP/Smart Cards

Zone Industrielle
13106 Rousset Cedex, France
Tel: (33) 4-42-53-60-00
Fax: (33) 4-42-53-60-01

1150 East Cheyenne Mtn. Blvd.
Colorado Springs, CO 80906, USA
Tel: 1(719) 576-3300
Fax: 1(719) 540-1759

Scottish Enterprise Technology Park
Maxwell Building
East Kilbride G75 0QR, Scotland
Tel: (44) 1355-803-000
Fax: (44) 1355-242-743

RF/Automotive

Theresienstrasse 2
Postfach 3535
74025 Heilbronn, Germany
Tel: (49) 71-31-67-0
Fax: (49) 71-31-67-2340

1150 East Cheyenne Mtn. Blvd.
Colorado Springs, CO 80906, USA
Tel: 1(719) 576-3300
Fax: 1(719) 540-1759

Biometrics/Imaging/Hi-Rel MPU/ High Speed Converters/RF Datacom

Avenue de Rochepleine
BP 123
38521 Saint-Egreve Cedex, France
Tel: (33) 4-76-58-30-00
Fax: (33) 4-76-58-34-80

Literature Requests

www.atmel.com/literature

Disclaimer: The information in this document is provided in connection with Atmel products. No license, express or implied, by estoppel or otherwise, to any intellectual property right is granted by this document or in connection with the sale of Atmel products. **EXCEPT AS SET FORTH IN ATMEL'S TERMS AND CONDITIONS OF SALE LOCATED ON ATMEL'S WEB SITE, ATMEL ASSUMES NO LIABILITY WHATSOEVER AND DISCLAIMS ANY EXPRESS, IMPLIED OR STATUTORY WARRANTY RELATING TO ITS PRODUCTS INCLUDING, BUT NOT LIMITED TO, THE IMPLIED WARRANTY OF MERCHANTABILITY, FITNESS FOR A PARTICULAR PURPOSE, OR NON-INFRINGEMENT. IN NO EVENT SHALL ATMEL BE LIABLE FOR ANY DIRECT, INDIRECT, CONSEQUENTIAL, PUNITIVE, SPECIAL OR INCIDENTAL DAMAGES (INCLUDING, WITHOUT LIMITATION, DAMAGES FOR LOSS OF PROFITS, BUSINESS INTERRUPTION, OR LOSS OF INFORMATION) ARISING OUT OF THE USE OR INABILITY TO USE THIS DOCUMENT, EVEN IF ATMEL HAS BEEN ADVISED OF THE POSSIBILITY OF SUCH DAMAGES.** Atmel makes no representations or warranties with respect to the accuracy or completeness of the contents of this document and reserves the right to make changes to specifications and product descriptions at any time without notice. Atmel does not make any commitment to update the information contained herein. Unless specifically provided otherwise, Atmel products are not suitable for, and shall not be used in, automotive applications. Atmel's products are not intended, authorized, or warranted for use as components in applications intended to support or sustain life.

© Atmel Corporation 2005. All rights reserved. Atmel®, logo and combinations thereof, Everywhere You Are® and others, are registered trademarks or trademarks of Atmel Corporation or its subsidiaries. Other terms and product names may be trademarks of others.



Printed on recycled paper.

4773B-AUTO-09/05