

TOSHIBA Bi-CMOS Integrated Circuit Silicon Monolithic

TB6556F/FG

3-Phase Full-Wave Sine-Wave PWM Brushless Motor Controller

Features

- Sine-wave PWM control
- Built-in triangular-wave generator
(carrier cycle = $f_{osc}/252$ (Hz))
- Built-in lead angle control function (0° to 58° in 32 steps)
External setting/automatic internal setting
- Built-in dead time function (setting 2.6 μ s or 3.8 μ s)
- Supports bootstrap circuit
- Overcurrent protection signal input pin
- Built-in regulator ($V_{refout} = 5$ V (typ.), 30 mA (max))
- Operating supply voltage range: $V_{CC} = 6$ V to 10 V

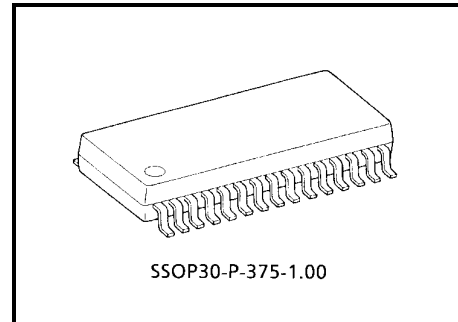

Weight: 0.33 g (typ.)

TB6556FG:

TB6556FG is a Pb-free product.

The following conditions apply to solderability:

*Solderability

1. Use of Sn-63Pb solder bath
 - *solder bath temperature = 230°C
 - *dipping time = 5 seconds
 - *number of times = once
 - *use of R-type flux
2. Use of Sn-3.0Ag-0.5Cu solder bath
 - *solder bath temperature = 245°C
 - *dipping time = 5 seconds
 - *the number of times = once
 - *use of R-type flux

Block Diagram

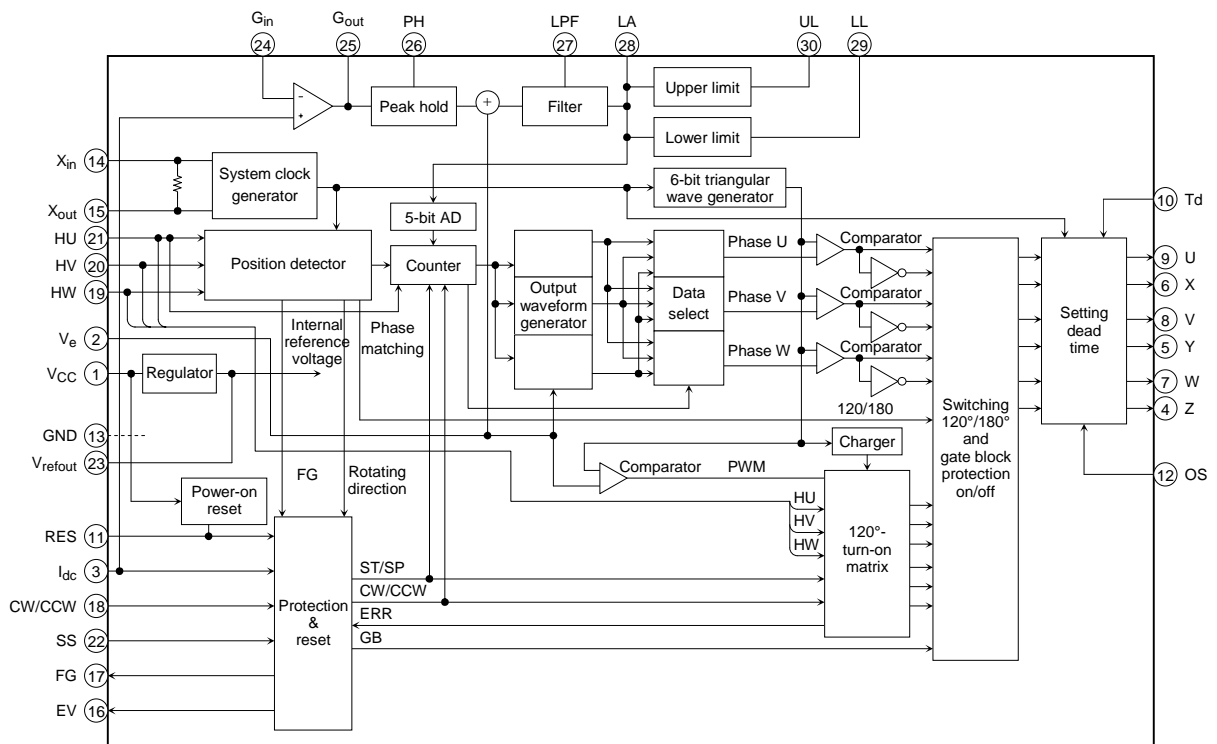

Pin Description

Pin No.	Symbol	Description	Remarks
21	HU	Positional signal input pin U	When positional signal is HHH or LLL, gate block protection operates. With built-in pull-up resistor, built-in digital filter (≈ 500 ns)
20	HV	Positional signal input pin V	
19	HW	Positional signal input pin W	
18	CW/CCW	Rotation direction signal input pin	L: Forward H: Reverse
11	RES	Reset-signal-input pin	L: Reset (output is non-active) operation/halt operation, also used for gate protection, built-in pull-up resistor
2	V_e	Voltage command signal	With built-in pull-down resistor
24	G_{in}	Gain setting	I_{dc} signal level at a gain that optimizes the LA
25	G_{out}		
26	PH	Peak hold	Connect the peak-hold capacitor and discharge resistor to GND, parallel to each other
27	LPF	RC low-pass filter	Connect the low-pass filter capacitor (built-in 100 k Ω resistor)
28	LA	Lead angle setting signal input pin	Sets 0° to 58° in 32 steps
29	LL	Lower limit for LA	Set lower limit for LA (LL = 0 V to 5.0 V)
30	UL	Upper limit for LA	Set upper limit for LA (UL = 0 V to 5.0 V)
12	OS	Inputs output logic select signal	L: Active LOW H: Active HIGH
3	I_{dc}	Inputs overcurrent protection signal	Inputs DC link current. Reference voltage: 0.5 V With built-in filter (≈ 1 μ s), built-in digital filter (≈ 1 μ s)
14	X_{in}	Inputs clock signal	With built-in feedback resistor
15	X_{out}	Outputs clock signal	
23	V_{refout}	Outputs reference voltage signal	5 V (typ.), 30 mA (max)
17	FG	FG signal output pin	Outputs 3 PPR of positional signal
16	REV	Reverse rotation detection signal	Detects reverse rotation.
9	U	Outputs turn-on signal	Select active HIGH or active LOW using the output logic select pin.
8	V	Outputs turn-on signal	
7	W	Outputs turn-on signal	
6	X	Outputs turn-on signal	
5	Y	Outputs turn-on signal	
4	Z	Outputs turn-on signal	
1	V_{CC}	Power supply voltage pin	$V_{CC} = 6$ to 10 V
10	T_d	Inputs setting dead time	L: 3.8 μ s, H or OPEN: 1.9 μ s
22	SS	120°/180° select signal	L: 120° turn-on mode, H or OPEN: 180° turn-on mode
13	GND	Ground pin	—

Input/Output Equivalent Circuits

Pin Description	Symbol	Input/Output Signal	Input/Output Internal Circuit
Positional signal input pin U Positional signal input pin V Positional signal input pin W	HU HV HW	Digital With Schmitt trigger Hysteresis 300 mV (typ.) Digital filter: 500 ns (typ.) L: 0.8 V (max) H: $V_{\text{refout}} - 1 \text{ V}$ (min)	
Forward/reverse switching input pin L: Forward (CW) H: Reverse (CCW)	CW/CCW	Digital L: 0.8 V (max) H: $V_{\text{refout}} - 1 \text{ V}$ (min)	
Reset input L: Stops operation (reset) H: Operates	RES	Digital L: 0.8 V (max) H: $V_{\text{refout}} - 1 \text{ V}$ (min)	
120°/180° select signal L: 120° turn-on mode H: 180° turn-on mode (OPEN)	SS	Digital With Schmitt trigger Hysteresis: 300 mV (typ.) L: 0.8 V (max) H: $V_{\text{refout}} - 1 \text{ V}$ (min)	
Voltage command signal 1.0 V < $V_e \leq 2.1 \text{ V}$ Refresh operation (X, Y, Z pins: ON duty of 8%)	V_e	Analog Input voltage range 0 to 5.4 V Input voltage of 5.4 V or higher is clipped to 5.4 V.	

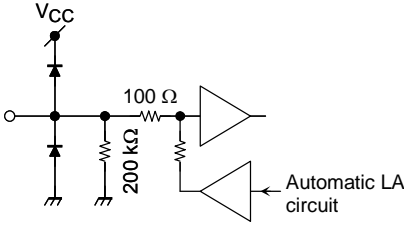
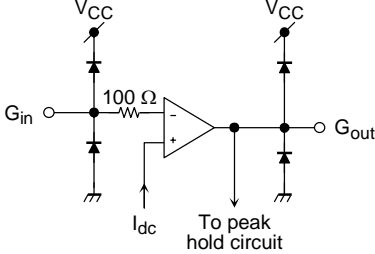
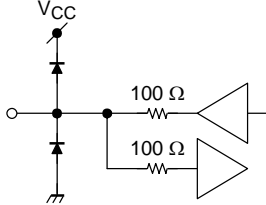
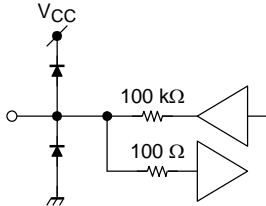
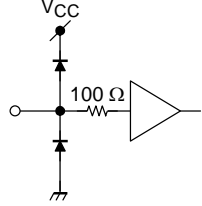
Pin Description	Symbol	Input/Output Signal	Input/Output Internal Circuit
Lead angle setting signal input pin 0 V: 0° 5 V: 58° (5-bit AD)	LA	When LA is fixed externally, connect LL to GND and UL to V_{refout} , and then input the setting voltage to the LA pin. Input voltage range: 0 V to 5.0 V (V_{refout}) Input voltage of V_{refout} or higher is clipped to V_{refout} . When LA is fixed automatically, open the LA pin. In this state, the LA pin is used only for confirmation of LA width.	
Gain setting signal input (LA setting)	G_{in} G_{out}	Non-inverted amplifier 25 dB (max) G_{out} output voltage LOW: GND HIGH: $V_{CC} - 1.7$ V	
Peak hold (LA setting)	PH	Connect the peak-hold capacitor and discharge resistor to GND, parallel to each other. 100 kΩ/0.1μF recommended	
Low-pass filter (LA setting)	LPF	Connect the low-pass filter capacitor (built-in 100 kΩ resistor) 0.1μF recommended	
Lower limit for LA	LL	Clip lower limit for LA LL = 0 V to 5.0 V When LL > UL, LA is fixed at LL value.	

Pin Description	Symbol	Input/Output Signal	Input/Output Internal Circuit
Upper limit for LA	UL	Clip upper limit for LA UL = 0 V to 5.0 V When LL > UL, LA is fixed at LL value.	
Setting dead time input pin L: 3.8 μs H or OPEN: 1.9 μs	Td	Digital L: 0.8 V (max) H: V _{refout} - 1 V (min)	
Output logic select signal input pin L: Active LOW H: Active HIGH	OS	Digital L: 0.8 V (max) H: V _{refout} - 1 V (min)	
Overcurrent protection signal input pin	I _{dc}	Analog Digital filter: 1 μs (typ.) Gate protected at 0.5 V or higher (released at carrier cycle)	
Clock signal input pin	X _{in}	Operating range 2 MHz to 8 MHz (crystal oscillation)	
Clock signal output pin	X _{out}		

Pin Description	Symbol	Input/Output Signal	Input/Output Internal Circuit
Reference voltage signal output pin	V_{refout}	$5 \pm 0.5 \text{ V}$ (max 30 mA)	
Reverse-rotation-detection signal output pin	REV	Digital Push-pull output: $\pm 1 \text{ mA}$ (max)	
FG signal output pin	FG	Digital Push-pull output: $\pm 1 \text{ mA}$ (max)	
Turn-on signal output pin U Turn-on signal output pin V Turn-on signal output pin W Turn-on signal output pin X Turn-on signal output pin Y Turn-on signal output pin Z	U V W X Y Z	Analog Push-pull output: $\pm 2 \text{ mA}$ (max) L: 0.78 V (max) H: $V_{refout} - 0.78 \text{ V}$ (min)	

Maximum Ratings (Ta = 25°C)

Characteristics	Symbol	Rating	Unit
Supply voltage	V _{CC}	12	V
Input voltage	V _{in} (1)	-0.3-V _{CC} (Note 1)	V
	V _{in} (2)	-0.3-V _{refout} + 0.3 (Note 2)	
Turn-on signal output current	I _{OUT}	2	mA
Power dissipation	P _D	1.50 (Note 3)	W
Operating temperature	T _{opr}	-30~115 (Note 4)	°C
Storage temperature	T _{stg}	-50~150	°C

Note 1: V_{in} (1) pin: V_e, LA, G_{in}, G_{out}, PH, LPF, LL, UL

Note 2: V_{in} (2) pin: HU, HV, HW, CW/CCW, RES, OS, I_{dc}, T_d, SS

Note 3: When mounted on PCB (universal 50 × 50 × 1.6 mm, Cu 30%)

Note 4: Operating temperature range is determined by the P_D – T_a characteristic.

Recommended Operating Conditions (Ta = 25°C)

Characteristics	Symbol	Min	Typ.	Max	Unit
Supply voltage	V _{CC}	6	7	10	V
Crystal oscillation frequency	X _{in}	2	4	8	MHz

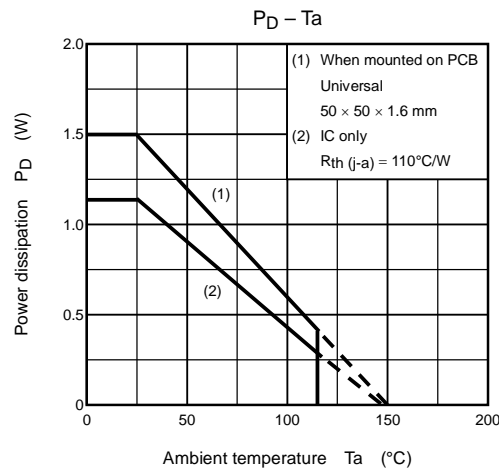

Electrical Characteristics (Ta = 25°C, VCC = 7 V)

Characteristics	Symbol	Test Circuit	Test Condition	Min	Typ.	Max	Unit
Supply current	I _{CC}	—	V _{refout} = open	—	5	8	mA
Input current	I _{in (1)-1}	—	V _{in} = 5 V LA	—	25	50	μA
	I _{in (1)-2}		V _{in} = 5 V V _e	—	35	70	
	I _{in (2)-1}		V _{in} = 0 V HU, HV, HW, SS	-50	-25	—	
	I _{in (2)-2}		V _{in} = 0 V CW/CCW, OS, Td, RES	-100	-50	—	
Input voltage	V _{in}	HIGH	HU, HV, HW, CW/CCW, RES, OS, Td, SS	V _{refout} - 1	—	V _{refout}	V
		LOW		—	—	0.8	
	V _e	H	PWM Duty 100%	5.1	5.4	5.7	V
		M	Refresh → Start motor operation	1.8	2.1	2.4	
L		Turned-off → Refresh	0.7	1.0	1.3		
Input hysteresis voltage	V _H	—	HU, HV, HW, SS (Note 5)	—	0.3	—	V
Input delay time	V _{DT}	—	HU, HV, HW X _{in} = 4.19 MHz	—	0.5	—	μs
	V _{DC}		I _{dc} X _{in} = 4.19 MHz	—	1.0	—	
Output voltage	V _{OUT (H)-1}	—	I _{OUT} = 2 mA U, V, W, X, Y, Z	V _{refout} - 0.78	V _{refout} - 0.3	—	V
	V _{OUT (L)-1}		I _{OUT} = -2 mA U, V, W, X, Y, Z	—	0.3	0.78	
	V _{REV (H)}		I _{OUT} = 1 mA REV	V _{refout} - 1.0	V _{refout} - 0.2	—	
	V _{REV (L)}		I _{OUT} = -1 mA REV	—	0.2	1.0	
	V _{FG (H)}		I _{OUT} = 1 mA FG	V _{refout} - 1.0	V _{refout} - 0.2	—	
	V _{FG (L)}		I _{OUT} = -1 mA FG	—	0.2	1.0	
	V _{refout}		I _{OUT} = 30 mA V _{refout}	4.5	5.0	5.5	
Output leakage current	I _{L (H)}	—	V _{OUT} = 0 V U, V, W, X, Y, Z	—	0	10	μA
	I _{L (L)}		V _{OUT} = 3.5 V U, V, W, X, Y, Z	—	0	10	
Output off-time by upper/lower transistor (Note 6)	T _{OFF (H)}	—	Td = HIGH or OPEN, X _{in} = 4.19 MHz, I _{OUT} = ± 2 mA, OS = HIGH/LOW	1.5	1.9	—	μs
	T _{OFF (L)}		Td = LOW, X _{in} = 4.19 MHz, I _{OUT} = ± 2 mA, OS = HIGH/LOW	3.0	3.8	—	
Overcurrent detection	V _{dc}	—	I _{dc}	0.46	0.5	0.54	V
LA gain setting amp	AMP _{OUT}	—	G _{OUT} output current	5	—	—	mA
	AMP _{OFS}		G _{IN} , G _{OUT} 11 kΩ/1 kΩ	—	-40	—	
LA limit setting difference	ΔL	—	LL = 0.7 V	-20	—	20	mV
	ΔU		UL = 2.0 V	-20	—	20	
LA peak hold output current	PH _{OUT}	—	PH output current	—	—	5	mA
Lead angle correction	T _{LA (0)}	—	LA = 0 V or OPEN, Hall IN = 100 Hz	—	0	—	°
	T _{LA (2.5)}	—	LA = 2.5 V, Hall IN = 100 Hz	27.5	32	34.5	
	T _{LA (5)}	—	LA = 5 V, Hall IN = 100 Hz	53.5	59	62.5	
V _{CC} monitor	V _{CC (H)}	—	Output start operation point	4.2	4.5	4.8	V
	V _{CC (L)}	—	No output operation point	3.7	4.0	4.3	
	V _H	—	Input hysteresis width	—	0.5	—	

Note 5: Toshiba does not implement testing before shipping.

Note 6: T_{OFF}

OS = HIGH

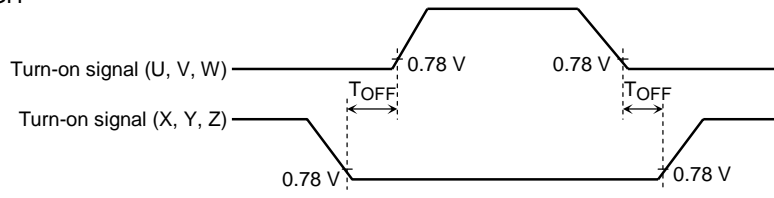

OS = LOW

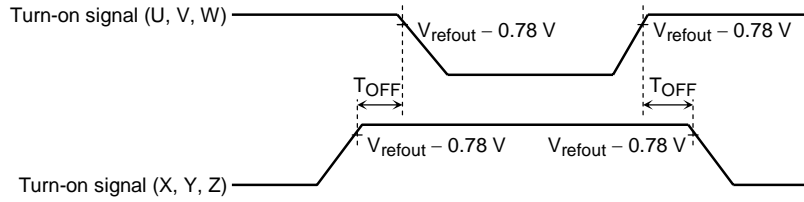

Functional Description

1. Basic operation

The motor is driven by the square-wave turn-on signal based on a positional signal. When the positional signal reaches number of rotations $f = 5$ Hz or higher, the rotor position is estimated according to the positional signal and a modulation wave is generated. The modulation wave and the triangular wave are compared; then the sine-wave PWM signal is generated and the motor is driven.

From start to 5 Hz: When driven by square wave (120° turn-on) $f = f_{osc}/(2^{12} \times 32 \times 6)$

5 Hz~: When driven by sine-wave PWM (180° turn-on); when $f_{osc} = 4$ MHz, approx. 5 Hz

2. Select drive function

This function can select drive mode.

SS pin

HIGH or OPEN = Sine-wave PWM drive (180° turn-on mode)

LOW = Square-wave drive (120° turn-on mode)

Note: If the position sensing signal is $f = 5$ Hz or lower, the driver is 120° turn-on mode even when SS = HIGH.

3. V_e voltage command signal function and function to stabilize bootstrap voltage

(1) When the voltage command signal is input at $V_e \leq 1.0$ V:

Turns off output (gate protection)

(2) When the voltage command signal is input at 1.0 V < $V_e \leq 2.1$ V:

Turns on the lower transistor at the regular (carrier) cycle. (ON duty is approx. 8%.)

(3) When the voltage command signal is input at $V_e > 2.1$ V:

During sin-wave drive, outputs drive signal as it is. During square-drive, forcibly turns on the lower transistor at regular (carrier) cycle. (ON duty is approx. 8%)

Note: At startup, turn the lower transistor on for a fixed time with 1.0 V < $V_e \leq 2.1$ V to charge the upper transistor gate power supply.

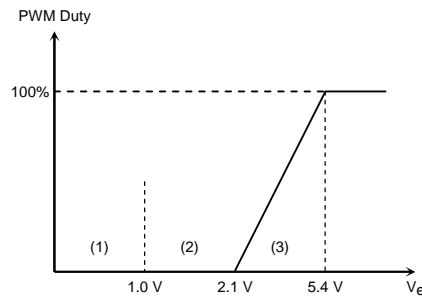

4. Dead time function: upper/lower transistor output off-time

When the motor is driven by sine-wave PWM, dead time is digitally generated in the IC to prevent a short circuit caused by the simultaneous turning on of upper and lower external power devices. When a square wave is generated in full-duty cycle mode, the dead time function is turned on to prevent a short circuit.

Td Pin	Internal Counter	T _{OFF}
HIGH or OPEN	$8/f_{osc}$	1.9 μ s
LOW	$16/f_{osc}$	3.8 μ s

T_{OFF} values above are obtained when $f_{osc} = 4.19$ MHz.

f_{osc} = reference clock (crystal oscillation)

5. Correcting the lead angle

The lead angle can be corrected in the turn-on signal range from 0 to 58° in relation to the induced voltage.

Analog input from LA pin (0 V to 5 V divided by 32):

0 V = 0°

5 V = 58° (when more than 5 V is input, 58°)

6. Setting the carrier frequency

This function sets the triangular wave cycle (carrier cycle) necessary for generating the PWM signal. (The triangular wave is used for forcibly turning on the lower transistor when the motor is driven by square wave.)

Carrier cycle = $f_{osc}/252$ (Hz) f_{osc} = reference clock (crystal oscillation)

7. Switching the output of the turn-on signal

This function switches the output of the turn-on signal between HIGH and LOW.

Pin OS:

HIGH = active HIGH

LOW = active LOW

8. Outputting the reverse rotation detection signal

This function detects the motor rotation direction every electrical angle of 360°. (The output is HIGH immediately after reset.)

The REV terminal increases with a 180° turn-on mode during LOW.

CW/CCW Pin	Actual Motor Rotating Direction	REV Pin
LOW (CW)	CW (forward)	LOW
	CCW (reverse)	HIGH
HIGH (CCW)	CW (forward)	HIGH
	CCW (reverse)	LOW

9. Protecting input pin

- Overcurrent protection (Pin Idc)

When the DC-link-current exceeds the internal reference voltage, performs gate block protection.

Overcurrent protection is released for each carrier frequency.

Reference voltage = 0.5 V (typ.)

- Gate protection (Pin RES)

Output is turned off when the input signal is LOW, restarted when the input signal is HIGH.

The abnormality is detected externally and the signal input to pin RES.

RES Pin	OS Pin	Output Turn-on Signal (U, V, W, X, Y, Z)
LOW	LOW	HIGH
	HIGH	LOW

(When RES = LOW, bootstrap capacitor charging stops.)

3. Internal protection

- Positional signal abnormality protection

Output is turned off when the positional signal is HHH or LLL; otherwise, it is restarted.

- Low power supply voltage protection (VCC monitor)

For power supply on/off outside the operating voltage range, the turn-on signal output is kept at high impedance outside the operating voltage range to prevent damage caused by power device short circuits.

However, if the voltage level is supplied from the V_e pin, this function is restricted, e.g., when $V_e > 4.9$ V is applied, low power supply voltage protection does not operate.

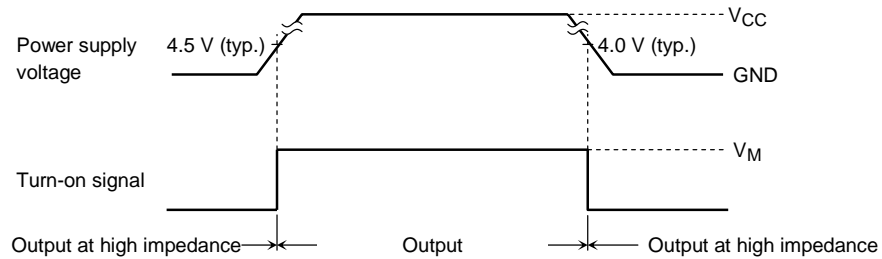

Operation Flow

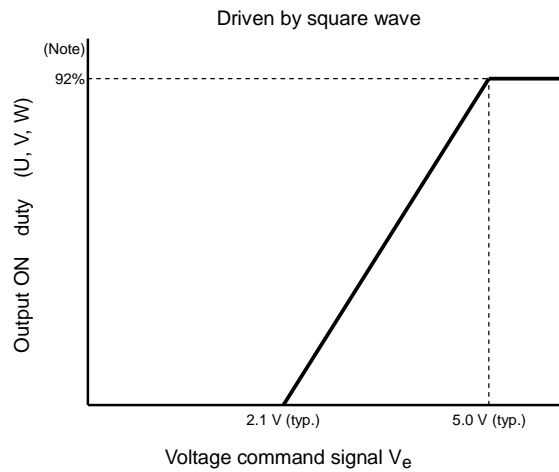
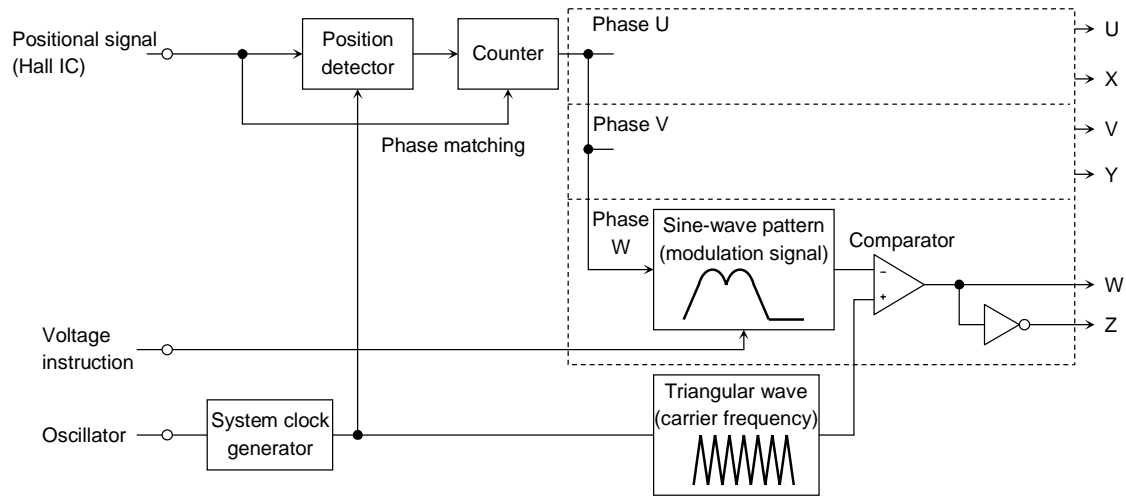

Note: Output ON time is decreased by the dead time
 $(\text{carrier frequency} \times 92\% - T_d \times 2)$

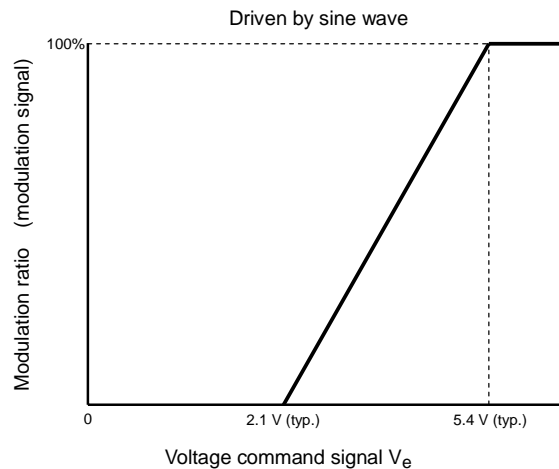

The modulation waveform is generated using Hall signals. The modulation waveform is then compared with the triangular wave and a sine-wave PWM signal is generated.

The time (electrical degrees: 60°) from the rising (or falling) edges of the three Hall signals to the next falling (or rising) edges is counted. The counted time is used as the data for the next 60° phase of the modulation waveform.

There are 32 items of data for the 60° phase of the modulation waveform. The time width of one data item is 1/32 of the time width of the 60° phase of the previous modulation waveform. The modulation waveform moves forward by the width.

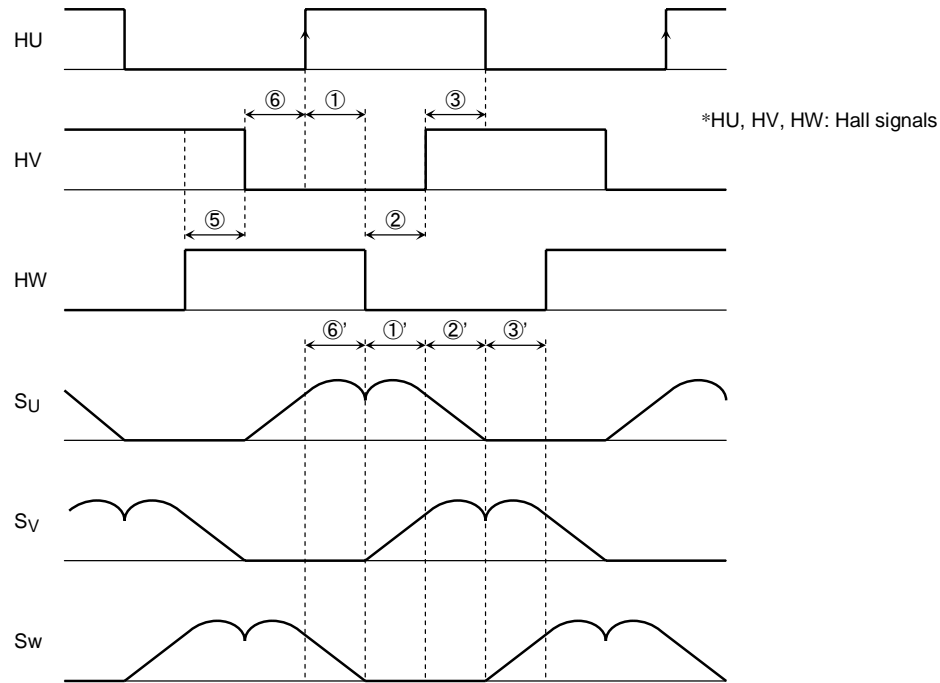

In the above diagram, the modulation waveform (1)' data moves forward by the 1/32 time width of the time (1) from HU: ↑ to HW: ↓. Similarly, data (2)' moves forward by the 1/32 time width of the time (2) from HW: ↓ to HV: ↑.

If the next edge does not occur after the 32 data items end, the next 32 data items move forward by the same time width until the next edge occurs.

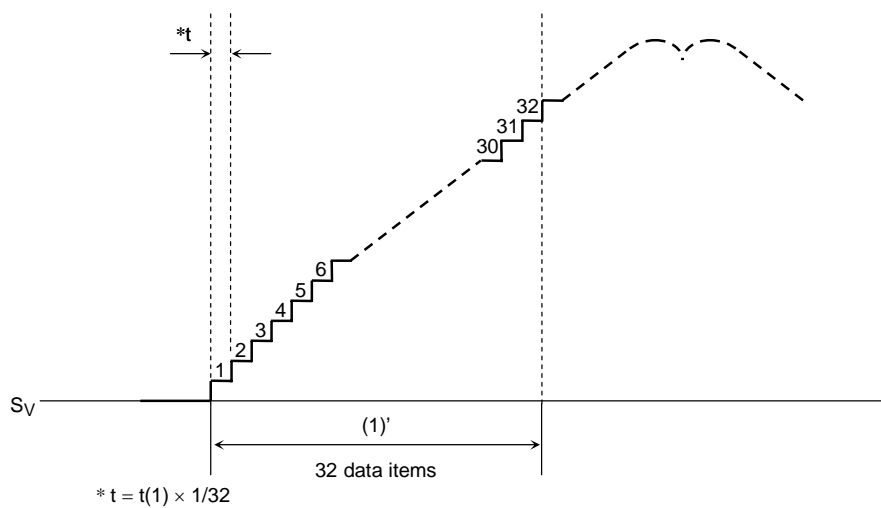

The modulation wave is brought into phase with every zero-cross point of the Hall signal.

The modulation wave is reset in synchronization with the rising and falling edges of the Hall signal at every 60° electrical angle. Thus, when the Hall device is not placed at the correct position or during acceleration and deceleration, the modulation waveform is not continuous at every reset.

Timing Charts

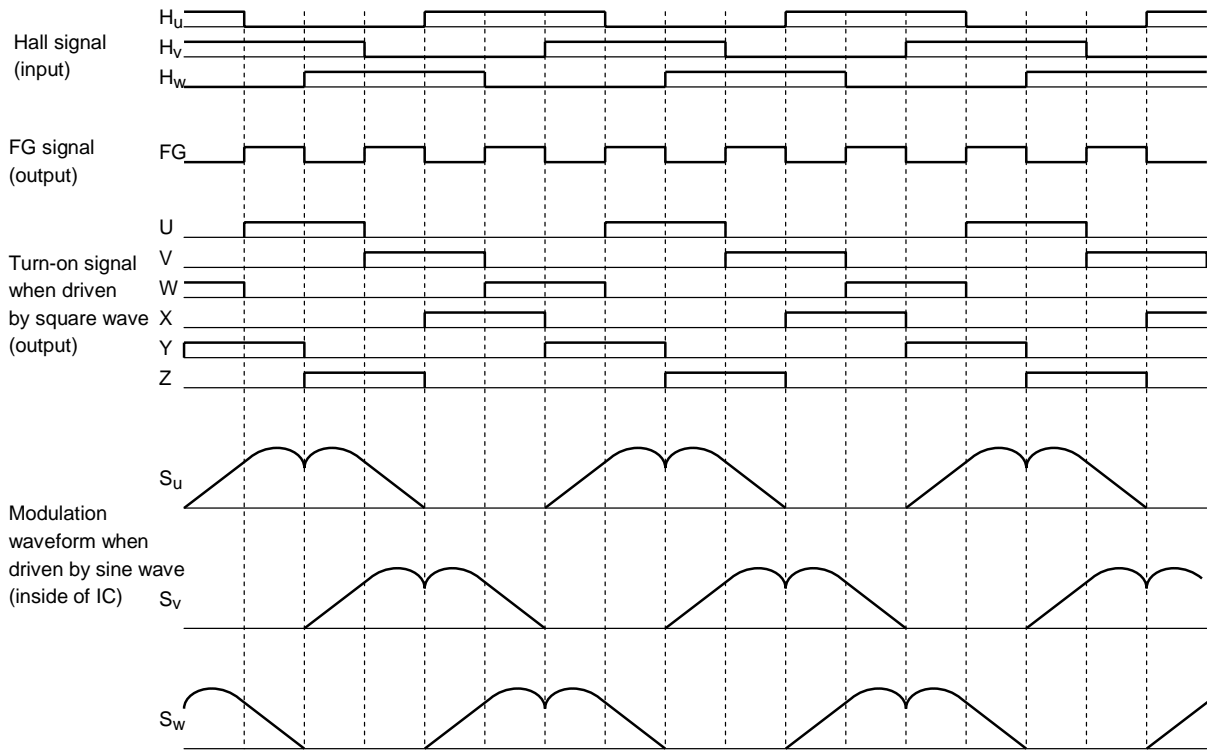

Forward

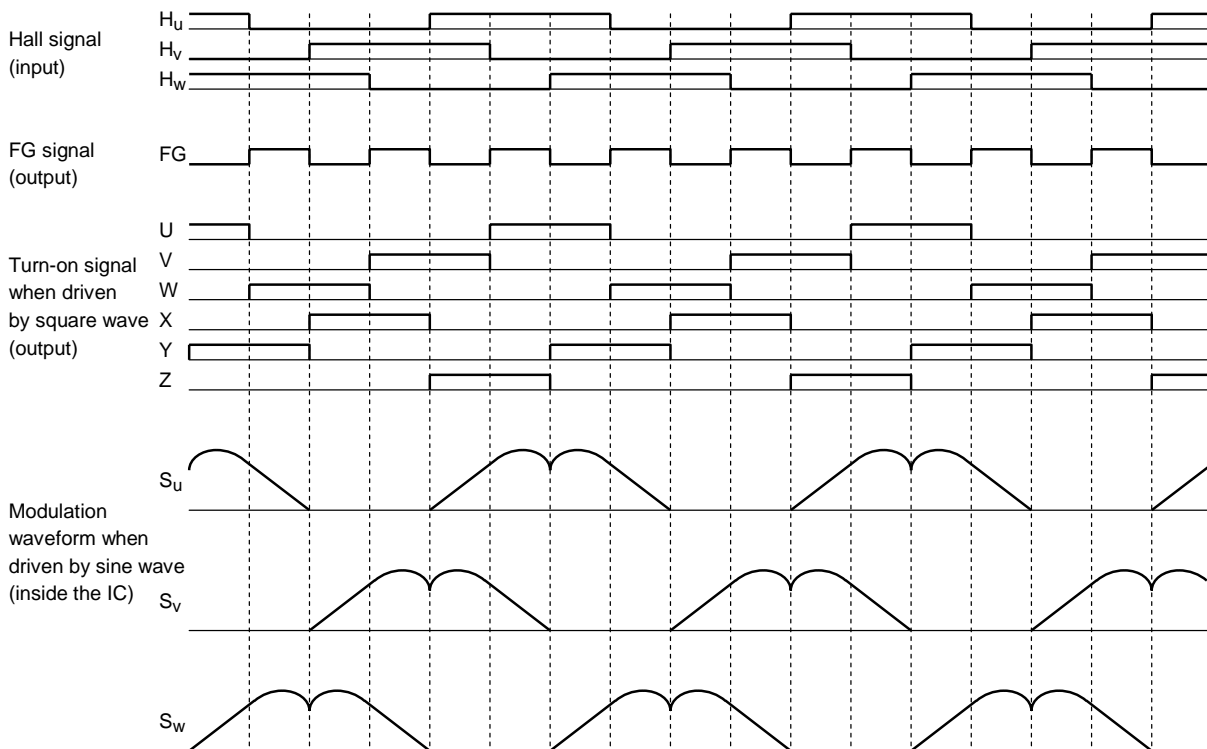

Reverse

Operating Waveform When Driven by Square Wave (CW/CCW = LOW, OS = HIGH)

Hall signal

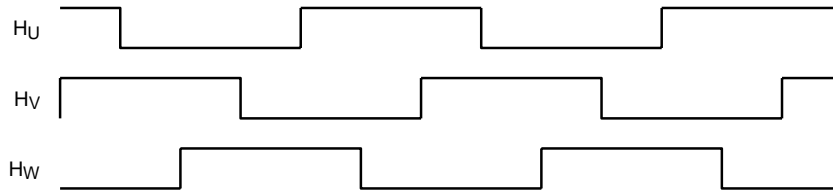

Output waveform

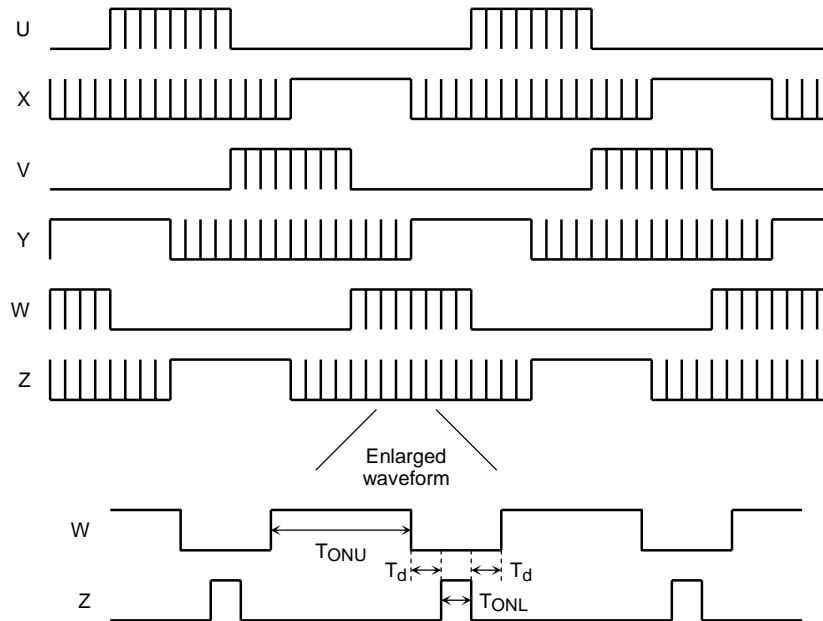

To stabilize the bootstrap voltage, the lower outputs (X, Y, and Z) are always turned on at the carrier cycle even during off time. At that time, the upper outputs (U, V, and W) are assigned dead time and turned off at the timing when the lower outputs are turned on. (T_d varies with input V_e)

$$\text{Carrier cycle} = f_{osc}/252 \text{ (Hz)}$$

$$\text{Dead time: } T_d = 16/f_{osc} \text{ (s) (In more than } V_e = 5.0 \text{ V)}$$

$$T_{ONL} = \text{carrier cycle} \times 8\% \text{ (s) (Uniformity)}$$

When the motor is driven by a square wave, acceleration or deceleration is determined by voltage V_e . The motor accelerates or decelerates according to the ON duty of T_{ONU} . (See the diagram of output ON duty on page 14.)

Note: At startup, the motor is driven by a square wave when the Hall signals are 5 Hz or lower ($f_{osc} = 4 \text{ MHz}$) and the motor is rotating in the reverse direction to that of the TB6556F/FG controlling it (REV = HIGH).

Operating Waveform When Driven by Sine-Wave PWM (CW/CCW = LOW, OS = HIGH)

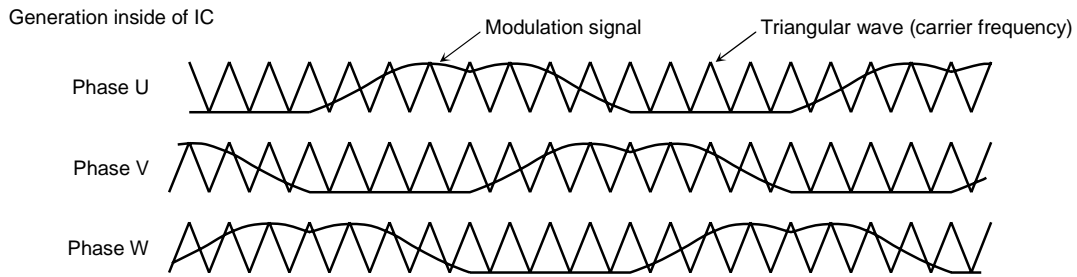

Output waveform

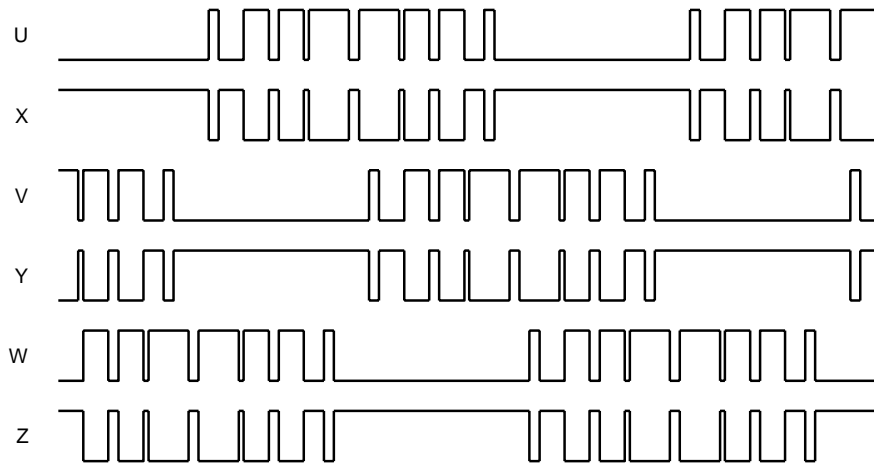

Inter-line voltage

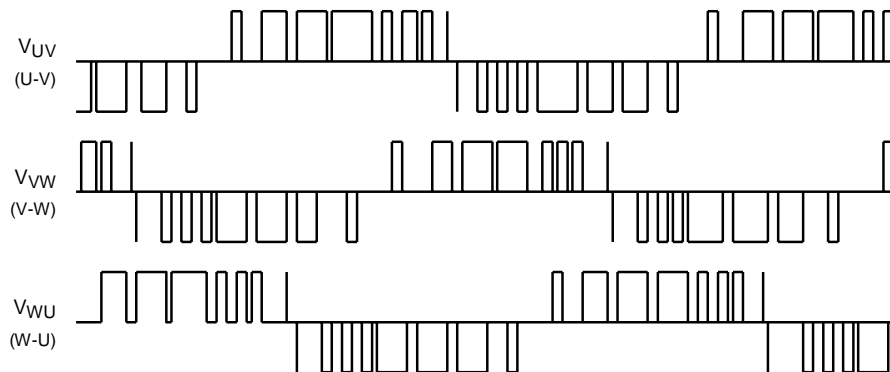

When driven by a sine wave, the motor is accelerated or decelerated according to the ON duty of TONU as the amplitude of the modulation symbol changes according to voltage V_e . (See the diagram of the output ON duty on page 14.)

$$\text{Triangular wave frequency} = \text{carrier frequency} = f_{osc}/252 \text{ (Hz)}$$

Note: At startup, the motor is driven by a sine wave when the Hall signals are 5 Hz or higher ($f_{osc} = 4 \text{ MHz}$) and the motor is rotating in the same direction as the TB6556F/FG controlling it (REV = LOW).

Example of Application Circuit

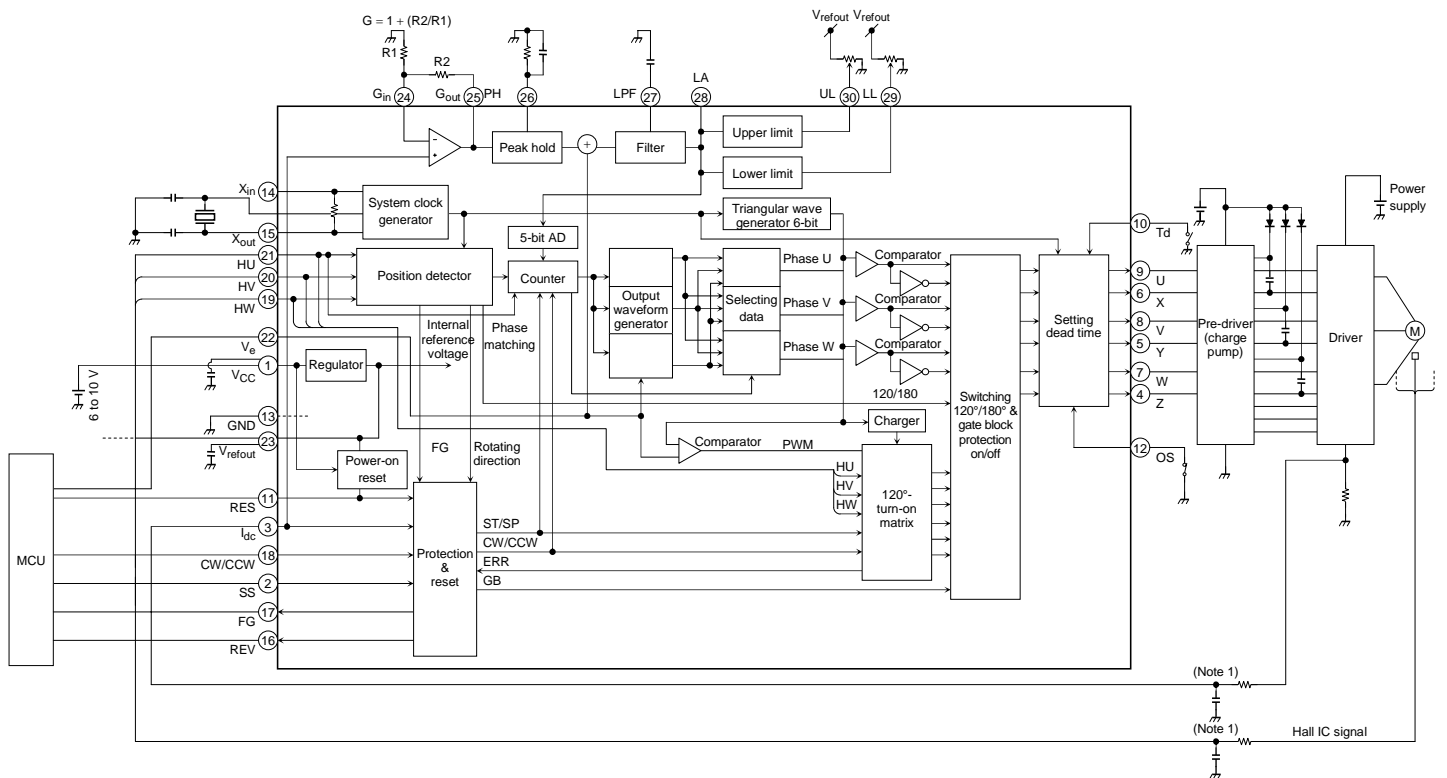

Note 1: Connect to ground as necessary to prevent IC malfunction due to noise.

Note 2: Connect GND to signal ground on the application circuit.

Note 3: The device may be damaged by short circuits between outputs or between output and supply or ground. Peripheral parts may also be damaged by overvoltage and overcurrent. Design the output lines, V_{CC} and GND lines to ensure that no short circuits occur.
Be careful also not to insert the IC in the wrong direction since this may destroy the IC.

Package Dimensions

SSOP30-P-375-1.00

Unit : mm

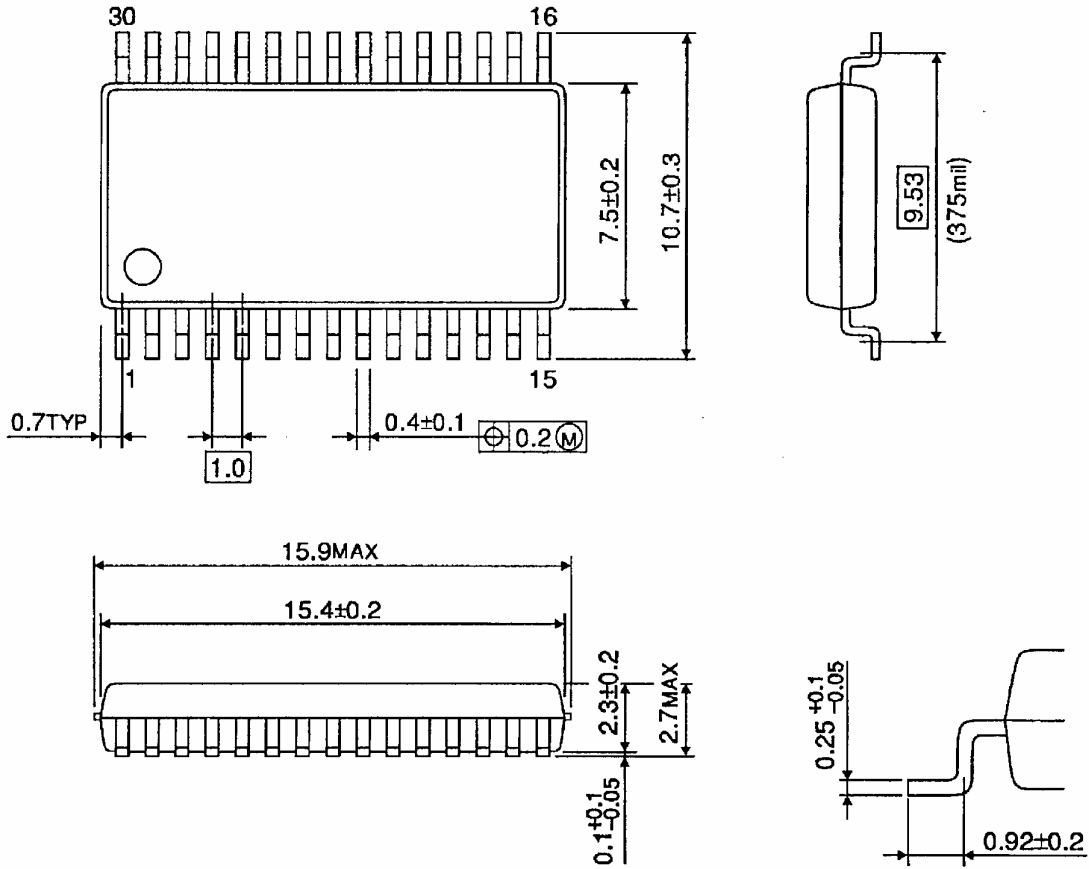

Weight: 0.63 g (typ.)

Notes on contents

1. Block Diagrams

Some of the functional blocks, circuits, or constants may be omitted or simplified in the block diagram for explanatory purposes.

2. Equivalent Circuits

The equivalent circuit diagrams may be simplified or some parts of them may be omitted for explanatory purposes.

3. Timing Charts

Timing charts may be simplified for explanatory purposes.

4. Maximum Ratings

The absolute maximum ratings of a semiconductor device are a set of specified parameter values that must not be exceeded during operation, even for an instant.

If any of these ratings are exceeded during operation, the electrical characteristics of the device may be irreparably altered, in which case the reliability and lifetime of the device can no longer be guaranteed.

Moreover, any exceeding of the ratings during operation may cause breakdown, damage and/or degradation in other equipment. Applications using the device should be designed so that no maximum rating will ever be exceeded under any operating conditions.

Before using, creating and/or producing designs, refer to and comply with the precautions and conditions set forth in this document.

5. Application Circuits

The application circuits shown in this document are provided for reference purposes only. Thorough evaluation is required in the mass production design phase.

In furnishing these examples of application circuits, Toshiba does not grant the use of any industrial property rights.

6. Test Circuits

Components in test circuits are used only to obtain and confirm device characteristics. These components and circuits are not guaranteed to prevent malfunction or failure in application equipment.

Handling of the IC

Ensure that the product is installed correctly to prevent breakdown, damage and/or degradation in the product or equipment.

Over-current protection and heat protection circuits

These protection functions are intended only as a temporary means of preventing output short circuits or other abnormal conditions and are not guaranteed to prevent damage to the IC.

If the guaranteed operating ranges of this product are exceeded, these protection features may not operate and some output short circuits may result in the IC being damaged.

The over-current protection feature is intended to protect the IC from temporary short circuits only.

Short circuits persisting over long periods may cause excessive stress and damage the IC. Systems should be configured so that any over-current condition will be eliminated as soon as possible.

Counter-electromotive force

When the motor reverses or stops, the effect of counter-electromotive force may cause the current to flow to the power source.

If the power supply is not equipped with sink capability, the power and output pins may exceed the maximum rating.

The counter-electromotive force of the motor will vary depending on the conditions of use and the features of the motor. Therefore make sure there will be no damage to or operational problem in the IC, and no damage to or operational errors in peripheral circuits caused by counter-electromotive force.

RESTRICTIONS ON PRODUCT USE

030619EBA

- The information contained herein is subject to change without notice.
- The information contained herein is presented only as a guide for the applications of our products. No responsibility is assumed by TOSHIBA for any infringements of patents or other rights of the third parties which may result from its use. No license is granted by implication or otherwise under any patent or patent rights of TOSHIBA or others.
- TOSHIBA is continually working to improve the quality and reliability of its products. Nevertheless, semiconductor devices in general can malfunction or fail due to their inherent electrical sensitivity and vulnerability to physical stress. It is the responsibility of the buyer, when utilizing TOSHIBA products, to comply with the standards of safety in making a safe design for the entire system, and to avoid situations in which a malfunction or failure of such TOSHIBA products could cause loss of human life, bodily injury or damage to property.
In developing your designs, please ensure that TOSHIBA products are used within specified operating ranges as set forth in the most recent TOSHIBA products specifications. Also, please keep in mind the precautions and conditions set forth in the "Handling Guide for Semiconductor Devices," or "TOSHIBA Semiconductor Reliability Handbook" etc..
- The TOSHIBA products listed in this document are intended for usage in general electronics applications (computer, personal equipment, office equipment, measuring equipment, industrial robotics, domestic appliances, etc.). These TOSHIBA products are neither intended nor warranted for usage in equipment that requires extraordinarily high quality and/or reliability or a malfunction or failure of which may cause loss of human life or bodily injury ("Unintended Usage"). Unintended Usage include atomic energy control instruments, airplane or spaceship instruments, transportation instruments, traffic signal instruments, combustion control instruments, medical instruments, all types of safety devices, etc.. Unintended Usage of TOSHIBA products listed in this document shall be made at the customer's own risk.
- The products described in this document are subject to the foreign exchange and foreign trade laws.
- TOSHIBA products should not be embedded to the downstream products which are prohibited to be produced and sold, under any law and regulations.