

# TB6537P, TB6537F

## 3-Phase Full-Wave Sensorless Controller for Brushless DC Motors

TB6537P/F is a 3-phase full-wave sensorless controller for brushless DC motors. It is capable of controlling voltage by PWM signal input. When combined with various drive circuits it can be used for various types of motors.

### Features

- 3-phase full-wave sensorless drive
- PWM control (PWM signal is supplied from external sources.)
- Turn-on signal output current: 20 mA
- Overcurrent protection function
- Forward/reverse modes
- Lead angle control function (0, 7.5, 15 and 30 degrees)
- Built-in lap turn-on function
- Two types of PWM output (upper PWM and upper/lower alternate PWM)

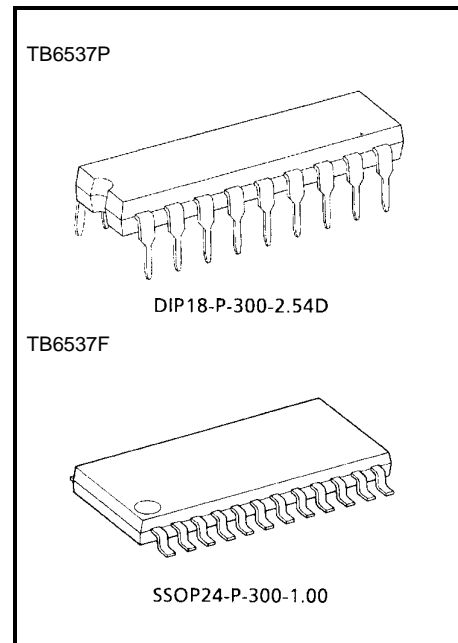

### Weight

DIP18-P-300-2.54D: 1.47 g (typ.)  
SSOP24-P-300-1.00: 0.32 g (typ.)

**Block Diagram**

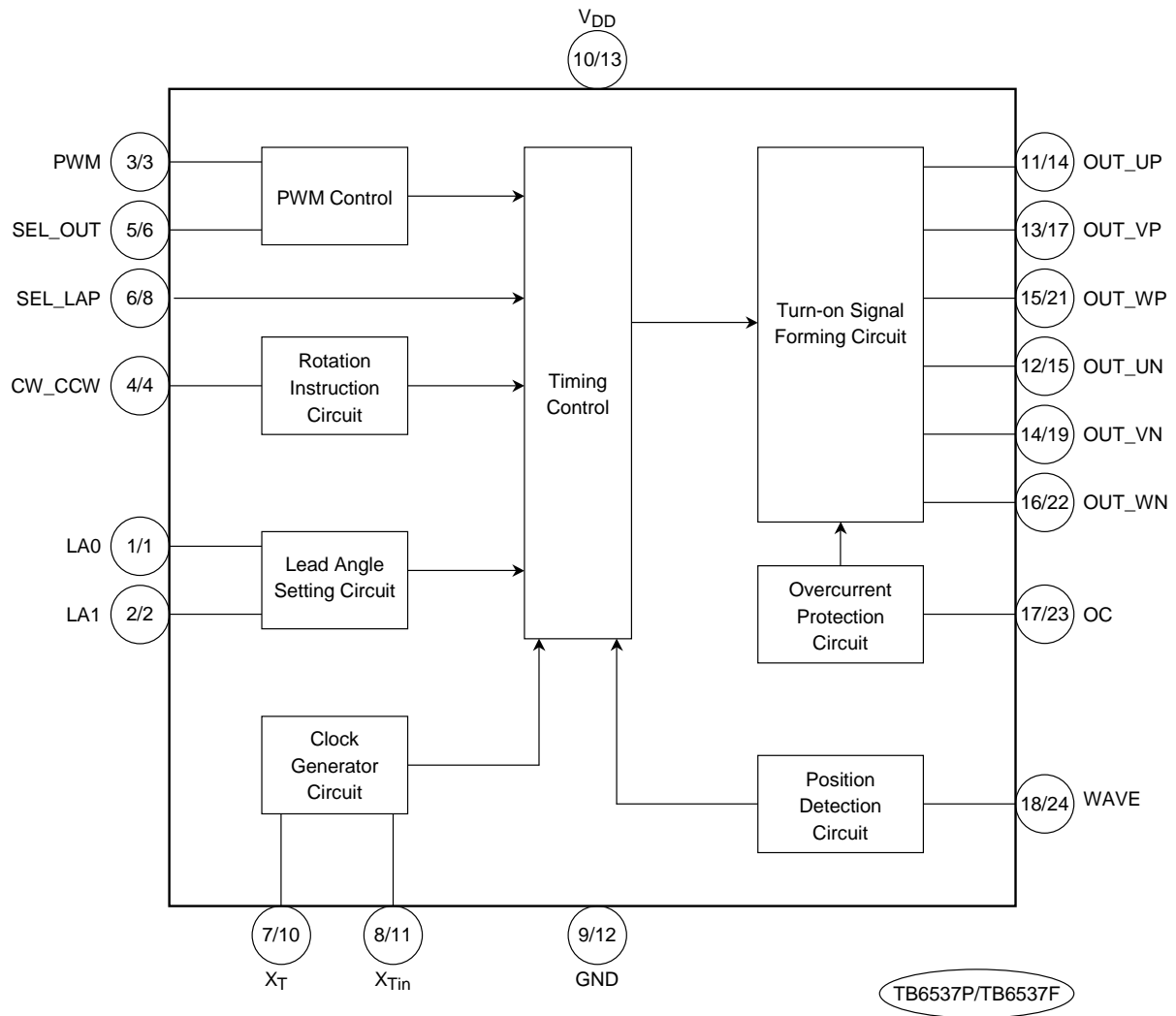

TB6537P/TB6537F

## Pin Assignment

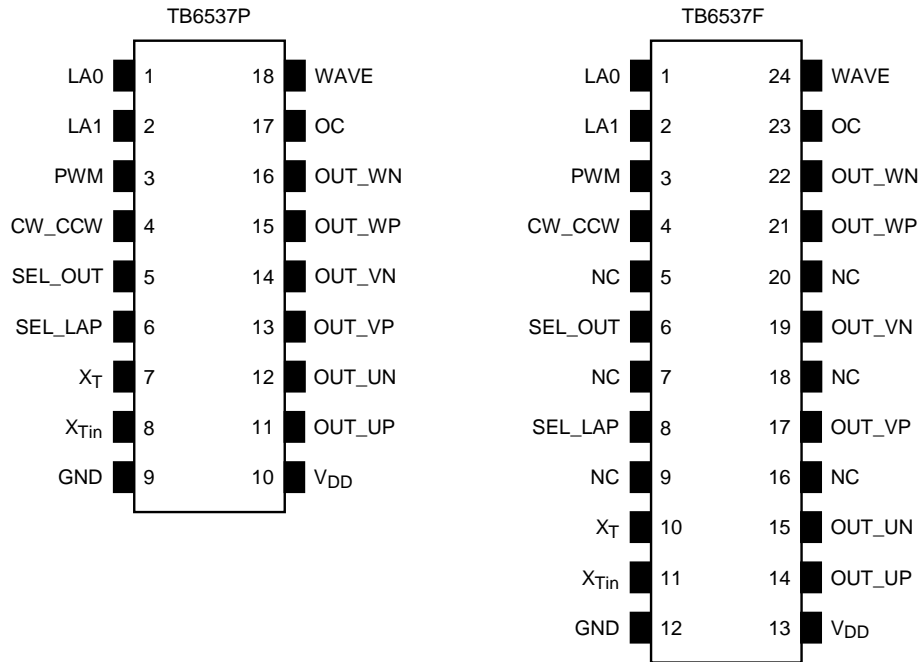

## Pin Description

Pin No.		Symbol	I/O	Description
TB6537P	TB6537F			
1	1	LA0	I	Lead angle setting signal input pin <ul style="list-style-type: none"> <li>LA0 = Low, LA1 = Low: Lead angle 0 degree</li> <li>LA0 = High, LA1 = Low: Lead angle 7.5 degree</li> </ul>
2	2	LA1	I	<ul style="list-style-type: none"> <li>LA0 = Low, LA1 = High: Lead angle 15 degree</li> <li>LA0 = High, LA1 = High: Lead angle 30 degree</li> <li>Built-in pull-down resistor</li> </ul>
3	3	PWM	I	PWM signal input pin <ul style="list-style-type: none"> <li>Inputs Low-active PWM signal</li> <li>Built-in pull-up resistor</li> <li>Disables input of duty-100% (Low) signal High for 250 ns or longer is required.</li> </ul>
4	4	CW_CCW	I	Rotation direction signal input pin <ul style="list-style-type: none"> <li>High: Reverse (U → W → V)</li> <li>Low, Open: Forward (U → V → W)</li> <li>Built-in pull-down resistor</li> </ul>
—	5	NC	—	Not connected
5	6	SEL_OUT	I	Pin to select the synthesis method of burn-in signal and PWM signal <ul style="list-style-type: none"> <li>Low: Upper PWM</li> <li>High: Upper/Lower alternate PWM</li> <li>Built-in pull-down resistor</li> </ul>
—	7	NC	—	Not connected
6	8	SEL_LAP	I	Lap turn-on select pin <ul style="list-style-type: none"> <li>Low: Lap turn-on</li> <li>High: 120 degrees turn-on</li> <li>Built-in pull-up resistor</li> </ul>
—	9	NC	—	Not connected
7	10	X <sub>T</sub>	—	Resonator connecting pin
8	11	X <sub>Tin</sub>	—	<ul style="list-style-type: none"> <li>Selects starting commutation frequency.</li> <li>Starting commutation frequency <math>f_{st} = \text{Resonator frequency } f_{xt}/(6 \times 2^{17})</math></li> </ul>
9	12	GND	—	Connected to GND.
10	13	V <sub>DD</sub>	—	Connected to 5-V power supply.
11	14	OUT_UP	O	U-phase upper turn-on signal output pin <ul style="list-style-type: none"> <li>U-phase winding wire positive ON/OFF switching pin</li> <li>ON: Low, OFF: High</li> </ul>
12	15	OUT_UN	O	U-phase lower turn-on signal output pin <ul style="list-style-type: none"> <li>U-phase winding wire negative ON/OFF switching pin</li> <li>ON: High, OFF: Low</li> </ul>
—	16	NC	—	Not connected
13	17	OUT_VP	O	V-phase upper turn-on signal output pin <ul style="list-style-type: none"> <li>V-phase winding wire positive ON/OFF switching pin</li> <li>ON: Low, OFF: High</li> </ul>
—	18	NC	—	Not connected
14	19	OUT_VN	O	V-phase lower turn-on signal output pin <ul style="list-style-type: none"> <li>V-phase winding wire negative ON/OFF switching pin</li> <li>ON: High, OFF: Low</li> </ul>

Pin No.		Symbol	I/O	Description
TB6537P	TB6537F			
—	20	NC	—	Not connected
15	21	OUT_WP	O	W-phase upper turn-on signal output pin <ul style="list-style-type: none"> <li>W-phase winding wire positive ON/OFF switching pin</li> <li>ON: Low, OFF: High</li> </ul>
16	22	OUT_WN	O	W-phase lower turn-on signal output pin <ul style="list-style-type: none"> <li>W-phase winding wire negative ON/OFF switching pin</li> <li>ON: High, OFF: Low</li> </ul>
17	23	OC	I	Overcurrent signal input pin <ul style="list-style-type: none"> <li>High on this pin can put constraints on the turn-on signal which is performing PWM control.</li> <li>Built-in pull-up resistor</li> </ul>
18	24	WAVE	I	Positional signal input pin <ul style="list-style-type: none"> <li>Inputs majority logic synthesis signal of three-phase pin voltage.</li> <li>Built-in pull-up resistor</li> </ul>

## Functional Description

### 1. Sensorless Drive

On receipt of PWM signal start instruction turn-in signal for forcible commutation (commutation irrespective of the motor's rotor position) is output and the motor starts to rotate. The motor's rotation causes induced voltage on winding wire pin for each phase.

When signals indicating positive or negative for pin voltage (including induced voltage) for each phase are input on respective positional signal input pin, the turn-on signal for forcible commutation is automatically switched to turn-on signal for positional signal (induced voltage).

Thereafter turn-on signal is formed according to the induced voltage contained in the pin voltage so as to drive the brushless DC motor.

### 2. Starting commutation frequency (resonator pin and counter bit select pin)

The forcible commutation frequency at the time of start is determined by the resonator's frequency and the number of counter bit (within the IC).

$$\text{Starting commutation frequency } f_{st} = \text{Resonator frequency } f_{xt} / (6 \times 2^{(\text{bit} + 3)}) \quad \text{bit} = 14$$

The forcible commutation frequency at the time of start can be adjusted using inertia of the motor and load.

- The forcible commutation frequency should be set higher as the number of magnetic poles increases.
- The forcible commutation frequency should be set lower as the inertia of the load increases.

### 3. PWM Control

PWM signal can be reflected in turn-on signal by supplying PWM signal from external sources.

The frequency of the PWM signal should be set adequately high with regard to the electrical frequency of the motor and in accordance to the switching characteristics of the drive circuit.

Because positional detection is performed in synchronization with the rising edges of PWM signal, positional detection cannot be performed with 0% duty or 100% duty.

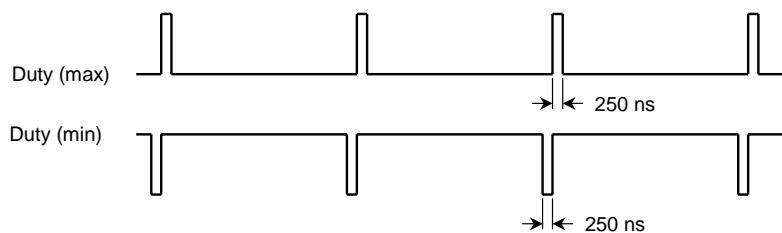

The voltage applied to the motor is duty 100% because of the storage time of the drive circuit even if the duty is 99%.

## 4. Selecting PWM Output Form

PWM output form can be selected using SEL\_OUT.

### SEL\_OUT = Low

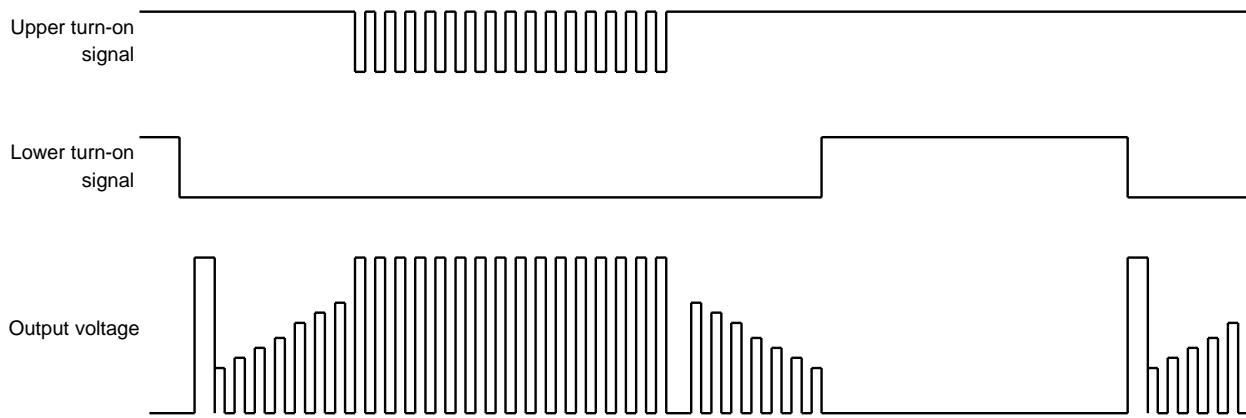

### SEL\_OUT = High

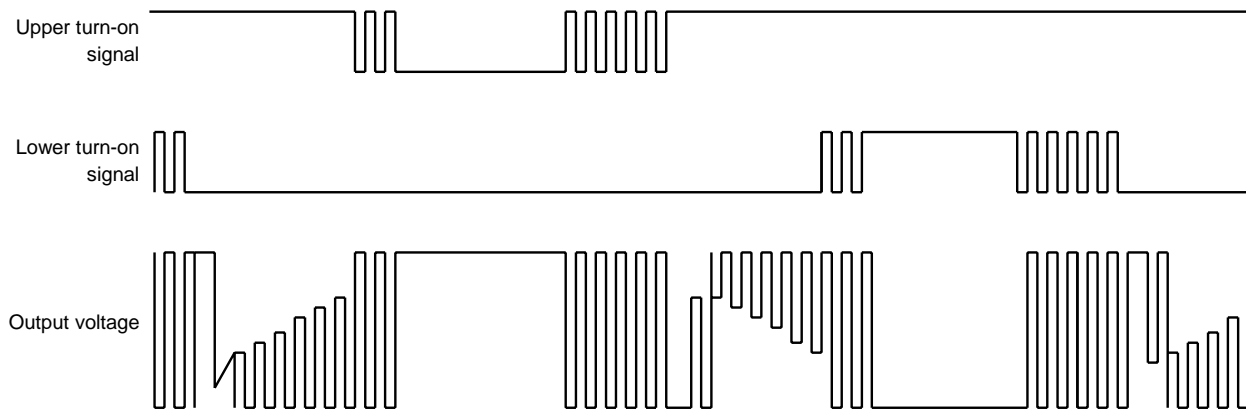

**5. Positional Variation**

Since positional detection is performed in synchronization with PWM signal, positional variation occurs in connection with the frequency of PWM signal. Be especially careful when the IC is used for high-speed motors.

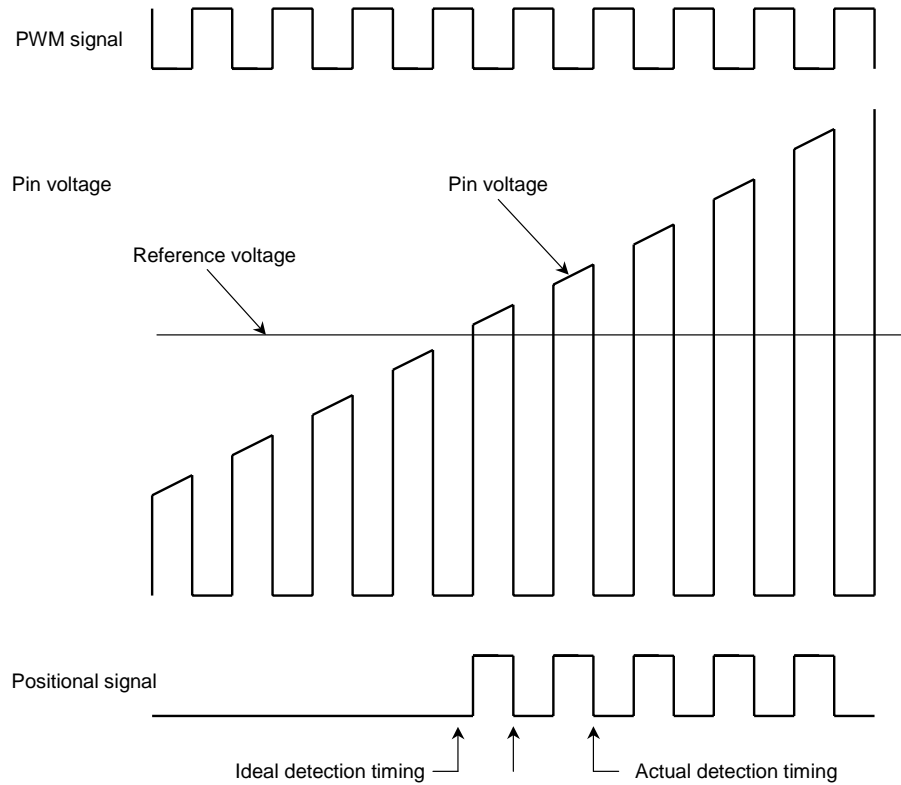

Variation is calculated by detecting at two consecutive rising edges of PWM signal.  
 $1/f_p < \text{Detection time variation} < 2/f_p$        $f_p$ : PWM frequency

**6. Overcurrent protection function**

An active phase which controls PWM is turned off by the rising-edge of the OC signal. The inactive phase is turned on by the timing of the next PWM signal.

### 7. Lead Angle Control

The lead angle is 0 degree during the starting forcible commutation and when normal commutation is started, automatically changes to the lead angle which has been set using LA0 and LA1. However, if both LA0 and LA1 are set for High, the lead angle is 30 degrees in the starting forcible commutation as well as in normal commutation.

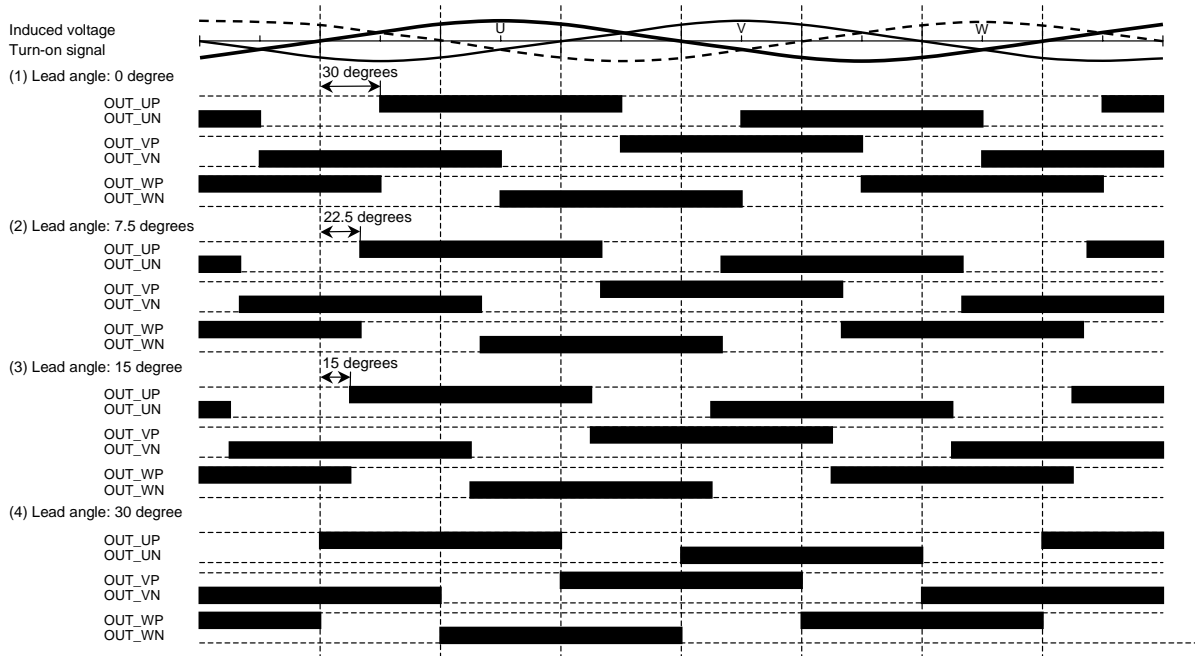

### 8. Lap Turn-on Control

When SEL\_LAP = High, the turn-on degree is 120 degrees. When SEL\_LAP = Low, Lap Turn-on Mode starts.

In Lap Turn-on Mode, the time between zero-cross point and the 120 degrees turn-on timing becomes longer (shaded area in the below chart) so as to create some overlap when switching turn on signals. The lap time differs depending on the lead angle setting.

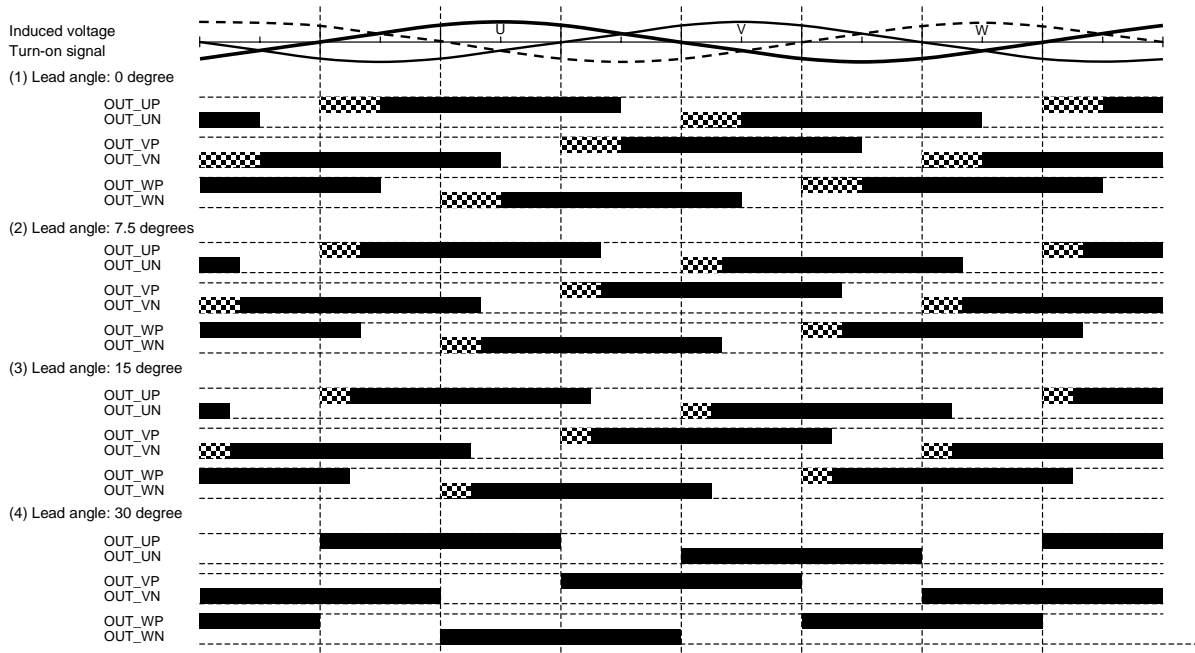



**9. Start/Stop Control**

Start/Stop is controlled using PWM signal input pin.

A stop is acknowledged when PWM signal duty is 0, and a start is acknowledged when ON-signal of a frequency 4 times higher than the resonator frequency or even higher is input continuously.

**Timing chart**

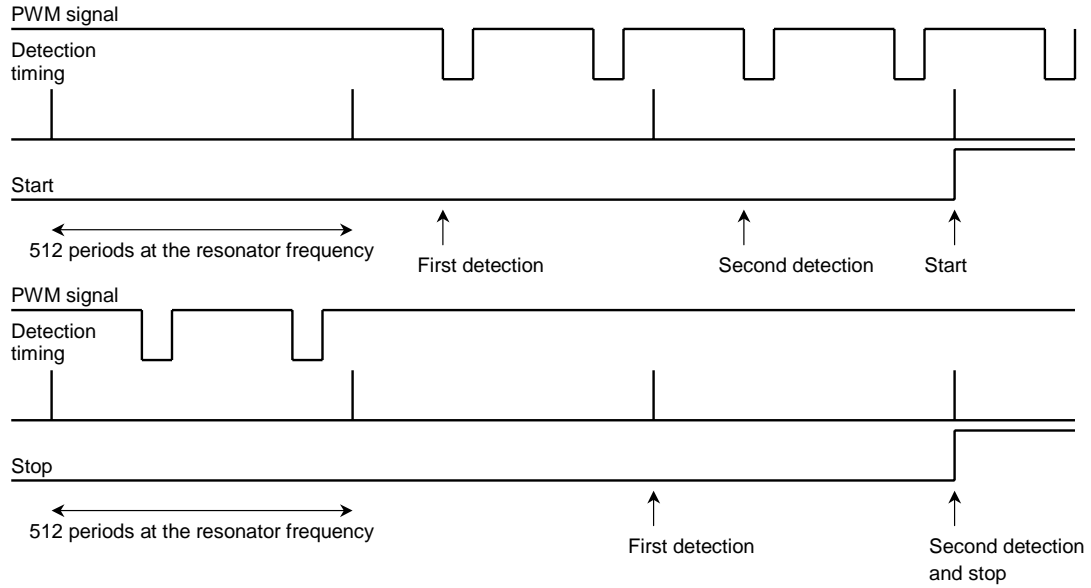

Note: Take sufficient care for noise on PWM signal input pin.

## Maximum Ratings (Ta = 25°C)

Characteristics	Symbol	Rating	Unit	
Power supply voltage	V <sub>DD</sub>	5.5	V	
Input voltage	V <sub>in</sub>	-0.3 to V <sub>DD</sub> + 0.3	V	
Turn-on signal output current	I <sub>OUT</sub>	20	mA	
Power dissipation	P <sub>D</sub>	TB6537P	1.25	W
		TB6537F	0.59	
Operating temperature	T <sub>opr</sub>	-30 to 85	°C	
Storage temperature	T <sub>stg</sub>	-55 to 150	°C	

## Recommended Operating Conditions (Ta = -30 to 85°C)

Characteristics	Symbol	Test Condition	Min	Typ.	Max	Unit
Power supply voltage	V <sub>DD</sub>	—	4.5	5.0	5.5	V
Input voltage	V <sub>in</sub>	—	-0.3	—	V <sub>DD</sub> + 0.3	V
PWM frequency	f <sub>PWM</sub>	—	—	16	—	kHz
Oscillation frequency	f <sub>osc</sub>	—	1.0	—	10	MHz

## Electrical Characteristics (Ta = 25°C, VDD = 5 V)

Characteristics	Symbol	Test Circuit	Test Condition	Min	Typ.	Max	Unit
Static power supply current	I <sub>DD</sub>	—	PWM = H, X <sub>Tin</sub> = H	—	0.1	0.3	mA
Dynamic power supply current	I <sub>DD (opr)</sub>	—	PWM = 50% Duty, X <sub>Tin</sub> = 4 MHz	—	1	3	mA
Input current	I <sub>IN-1 (H)</sub>	—	V <sub>IN</sub> = 5 V, PWM, OC, WAVE_U, SEL_LAP	—	0	1	μA
	I <sub>IN-1 (L)</sub>	—	V <sub>IN</sub> = 0 V, PWM, OC, WAVE_U, SEL_LAP	-75	-50	—	
	I <sub>IN-2 (H)</sub>	—	V <sub>IN</sub> = 5 V, CW_CCW, LA0, LA1, SEL_OUT	—	50	75	
	I <sub>IN-2 (L)</sub>	—	V <sub>IN</sub> = 0 V, CW_CCW, LA0, LA1, SEL_OUT	-1	0	—	
Input voltage	V <sub>IN (H)</sub>	—	PWM, OC, SEL_LAP, CW_CCW WAVE_U, LA0, LA1, SEL_OUT	3.5	—	5	V
	V <sub>IN (L)</sub>	—	PWM, OC, SEL_LAP, CW_CCW WAVE_U, LA0, LA1, SEL_OUT	GND	—	1.5	
Input hysteresis voltage	V <sub>H</sub>	—	PWM, OC, SEL_LAP, CW_CCW WAVE_U, LA0, LA1, SEL_OUT	—	0.6	—	V
Output voltage	V <sub>O-1 (H)</sub>	—	I <sub>OH</sub> = -1 mA OUT_UP, OUT_VP, OUT_WP	4.3	—	V <sub>DD</sub>	V
	V <sub>O-1 (L)</sub>	—	I <sub>OH</sub> = 20 mA OUT_UP, OUT_VP, OUT_WP	GND	—	0.5	
	V <sub>O-2 (H)</sub>	—	I <sub>OH</sub> = -20 mA OUT_UN, OUT_VN, OUT_WN	4.0	—	V <sub>DD</sub>	
	V <sub>O-2 (L)</sub>	—	I <sub>OH</sub> = 1 mA OUT_UN, OUT_VN, OUT_WN	GND	—	0.5	
Output leak current	I <sub>L (H)</sub>	—	V <sub>DD</sub> = 5.5 V, V <sub>OUT</sub> = 0 V OUT_UP, OUT_VP, OUT_WP OUT_UN, OUT_VN, OUT_WN	—	0	10	μA
	I <sub>L (L)</sub>	—	V <sub>DD</sub> = 5.5 V, V <sub>OUT</sub> = 5.5 V OUT_UP, OUT_VP, OUT_WP OUT_UN, OUT_VN, OUT_WN	—	0	10	
Output delay time	t <sub>pLH</sub>	—	PWM-Output	—	0.5	1	μs
	t <sub>pHL</sub>			—	0.5	1	

## Application Circuit Example

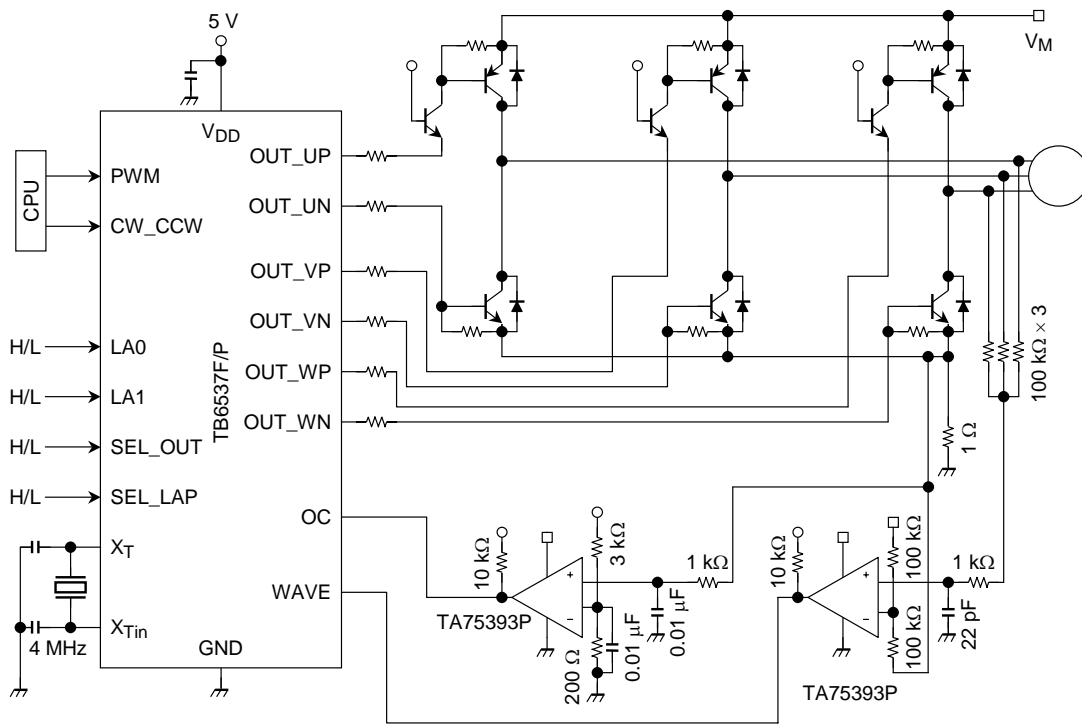

Note 1: Take enough care in designing output  $V_{DD}$  line and GND line to avoid short circuit between outputs,  $V_{DD}$  fault or GND fault which may cause the IC to break down.

Note 2: The above application circuit and values mentioned are just an example for reference. Since the values may vary depending on the motor to be used, appropriate values must be determined through experiments before using the device.



## Package Dimensions

SSOP24-P-300-1.00

Unit : mm

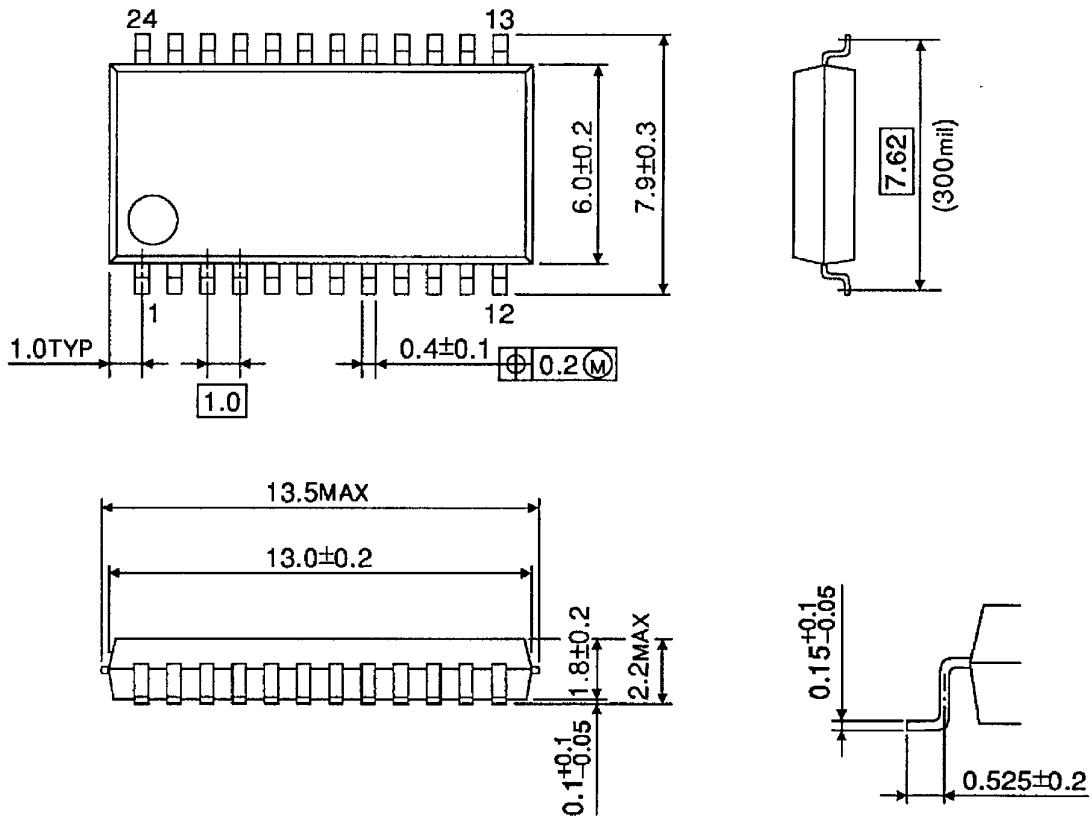

Weight: 0.32 (typ.)

**RESTRICTIONS ON PRODUCT USE**

000707EBA

- TOSHIBA is continually working to improve the quality and reliability of its products. Nevertheless, semiconductor devices in general can malfunction or fail due to their inherent electrical sensitivity and vulnerability to physical stress. It is the responsibility of the buyer, when utilizing TOSHIBA products, to comply with the standards of safety in making a safe design for the entire system, and to avoid situations in which a malfunction or failure of such TOSHIBA products could cause loss of human life, bodily injury or damage to property.  
In developing your designs, please ensure that TOSHIBA products are used within specified operating ranges as set forth in the most recent TOSHIBA products specifications. Also, please keep in mind the precautions and conditions set forth in the "Handling Guide for Semiconductor Devices," or "TOSHIBA Semiconductor Reliability Handbook" etc..
- The TOSHIBA products listed in this document are intended for usage in general electronics applications (computer, personal equipment, office equipment, measuring equipment, industrial robotics, domestic appliances, etc.). These TOSHIBA products are neither intended nor warranted for usage in equipment that requires extraordinarily high quality and/or reliability or a malfunction or failure of which may cause loss of human life or bodily injury ("Unintended Usage"). Unintended Usage include atomic energy control instruments, airplane or spaceship instruments, transportation instruments, traffic signal instruments, combustion control instruments, medical instruments, all types of safety devices, etc.. Unintended Usage of TOSHIBA products listed in this document shall be made at the customer's own risk.
- The products described in this document are subject to the foreign exchange and foreign trade laws.
- The information contained herein is presented only as a guide for the applications of our products. No responsibility is assumed by TOSHIBA CORPORATION for any infringements of intellectual property or other rights of the third parties which may result from its use. No license is granted by implication or otherwise under any intellectual property or other rights of TOSHIBA CORPORATION or others.
- The information contained herein is subject to change without notice.