

AN44

A high power LED driver for low voltage halogen replacement

Introduction

LED lighting is becoming more popular as a replacement technology for Halogen low voltage lighting, primarily because of the low efficiency, reliability and lifetime issues associated with Halogen bulbs.

Discussed below is a novel approach for driving high power LED's as a replacement for low voltage halogen lighting systems.

A typical schematic diagram is shown in Figure 1.

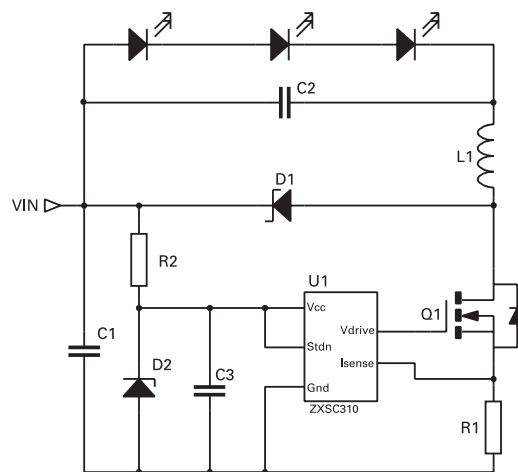

Figure 1 Schematic diagram

Operation

Please refer to the typical schematic diagram in Figure 1.

On period, T_{ON}

The ZXSC300 turns on Q1 until it senses 19mV (nominal) on the I_{SENSE} pin.

The current in Q1 to reach this threshold is therefore $19mV/R1$, called I_{PEAK} .

With Q1 on, the current is drawn from the battery and passes through C1 and LED in parallel. Assume the LED drops a forward voltage V_F . The rest of the battery voltage will be dropped across L1 and this voltage, called $V(L1)$ will ramp up the current in L1 at a rate $di/dt = V(L1)/L1$, di/dt in Amps/sec, $V(L1)$ in volts and L1 in Henries.

The voltage drop in Q1 and R1 should be negligible, since Q1 should have a low $R_{DS(on)}$ and R1 always drops less than 19mV, as this is the turn-off threshold for Q1.

$$V_{IN} = V_F + V(L1)$$

$$T_{ON} = I_{PEAK} \times L1 / V(L1)$$

AN44

So T_{ON} can be calculated, as the voltage across L1 is obtained by subtracting the forward LED voltage drop from V_{IN} . Therefore, if L1 is smaller, T_{ON} will be smaller for the same peak current I_{PEAK} and the same battery voltage V_{IN} . Note that, while the inductor current is ramping up to I_{PEAK} , the current is flowing through the LED and so the average current in the LED is the sum of the ramps during the T_{ON} ramping up period and the T_{OFF} ramping down period.

Off period, T_{OFF}

The T_{OFF} of ZXSC300 and ZXSC310 is fixed internally at nominally $1.7\mu s$. Note that, if relying on this for current ramp calculations, the limits are $1.2\mu s$ min., $3.2\mu s$ max.

In order to minimize the conductive loss and switching loss, T_{ON} should not be much smaller than T_{OFF} . Very high switching frequencies cause high dv/dt and it is recommended that the ZXSC300 and 310 are operated only up to 200 kHz. Given the fixed T_{OFF} of $1.7\mu s$, this gives a T_{ON} of $(5\mu s - 1.7\mu s) = 3.3\mu s$ minimum. However, this is not an absolute limitation and these devices have been operated at 2 or 3 times this frequency, but conversion efficiency can suffer under these conditions.

During T_{OFF} , the energy stored in the inductor will be transferred to the LED, with some loss in the Schottky diode. The energy stored in the inductor is:

$$\frac{1}{2} \times L \times I_{PEAK}^2 \quad [\text{Joules}]$$

Continuous and discontinuous modes (and average LED current)

If T_{OFF} is exactly the time required for the current to reach zero, the average current in the LED will be $I_{PEAK}/2$. In practice, the current might reach zero before T_{OFF} is complete and the average current will be less because part of the cycle is spent with zero LED current. This is called the 'discontinuous' operation mode and is shown in Figure 2.

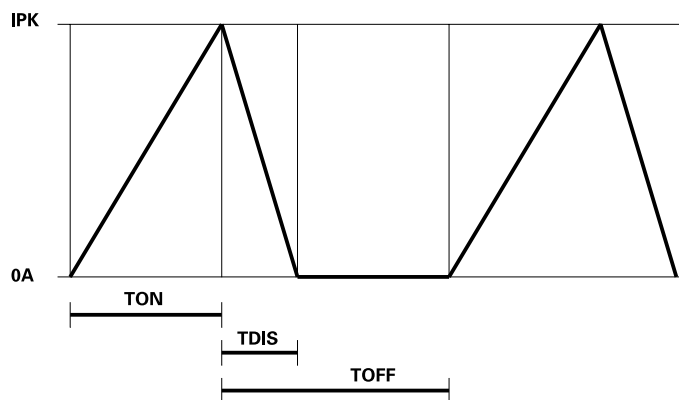

Figure 2

For continuous mode

If the current does not reach zero after $1.7\mu\text{s}$, but instead falls to a value of I_{MIN} , then the device is said to be in 'continuous' mode. The LED current will ramp up and down between I_{MIN} and I_{PEAK} (probably at different di/dt rates) and the average LED current will therefore be the average of I_{PEAK} and I_{MIN} , as shown in Figure 3.

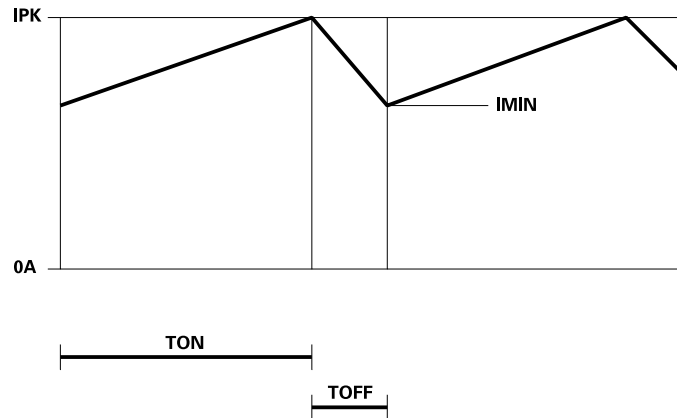

Figure 3

Design example

(Refer to Figure 1 and Table 1)

$$\text{Input} = V_{\text{IN}} = 12\text{V}$$

$$\text{LED forward drop} = V_{\text{LED}} = 9.6\text{V}$$

$$V_{\text{IN}} = V_{\text{LED}} + V_{\text{L}}$$

$$\text{Therefore } V_{\text{L}} = (12 - 9.6) = 2.4$$

$$\text{The peak current} = V_{\text{SENSE}} / R1$$

$$(R1 \text{ is } R_{\text{SENSE}}) = 24\text{mV} / 50\text{m}\Omega = 480\text{mA}$$

$$T_{\text{ON}} = I_{\text{PEAK}} \times L1 / V(L1)$$

$$T_{\text{ON}} = \frac{680\text{mA} \times 22\mu\text{H}}{2.4} = 6.2\mu\text{s}$$

These equations make the approximation that the LED forward drop is constant throughout the current ramp. In fact it will increase with current, but they still enable design calculations to be made within the tolerances of the components used in a practical circuit. Also, the difference between V_{IN} and V_{LED} is small compared to either of them, so the $6.2\mu\text{s}$ ramp time will be fairly dependent on these voltages.

Note that, for an LED drop of 9.6V and a Schottky drop of 300mV , the time to ramp down from 680mA to zero would be:

$$T_{\text{DIS}} = \frac{680\text{mA} \times 22\mu\text{H}}{(9.6 + 0.3)} = 1.5\mu\text{s}$$

AN44

As the T_{OFF} period is nominally $1.7\mu s$, the current should have time to reach zero. However, $1.5\mu s$ is rather close to $1.7\mu s$ and it is possible that, over component tolerances, the coil current will not reach zero, but this is not a big issue as the remaining current will be small. Note that, because of the peak current measurement and switch-off, it is not possible to get the dangerous 'inductor staircasing' which occurs in converters with fixed T_{ON} times. The current can never exceed I_{PEAK} , so even if it starts from a finite value (i.e. continuous mode) it will not exceed the I_{PEAK} . The LED current will therefore be approximately the average of $680mA$ and zero = $340mA$ (it will not be exactly the average, because there is a $200ns$ period at zero current, but this is small compared with the I_{PEAK} and component tolerances).

Ref	Value	Part number	Manufacturer	Contact details	Comments
U1		ZXSC310E5	Zetex	www.zetex.com	LED Driver in SOT23-5
Q1		ZXMN6A07F	Zetex	www.zetex.com	N-channel MOSFET in SOT23
D1	1A / 40V	ZHCS1000	Zetex	www.zetex.com	1A Schottky diode in SOT23
D2	6V8	Generic	Generic		6V8 Zener diode
L1	$22\mu H$	DO3316P-223	Coilcraft	www.coilcraft.com	
R1	$50m\Omega$	Generic	Generic		0805 size
R2	$1k2\Omega$	Generic	Generic		0805 size
C1	$100\mu F/25V$	Generic	Generic		
C2	$1\mu F/10V$	Generic	Generic		
C3	$2.2\mu F/25V$	Generic	Generic		

Table 1 Bill of materials

Typical performance graphs for 12V system

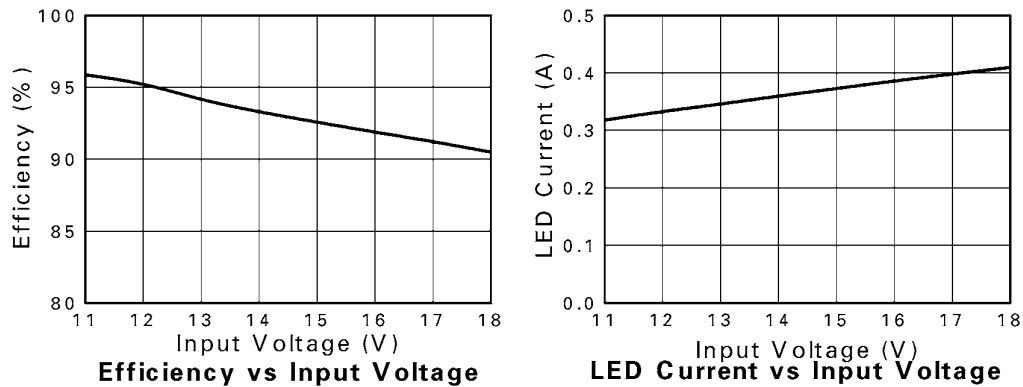

Figure 4 Performance graphs for 12V system

By changing the value of R2 from 1k Ω to 2k Ω the operating input voltage range can be adjusted from 30V to 20V, therefore the solution is able to operate from the typical operating voltage supplies of 12V and 24V for low voltage lighting.

Typical performance graphs for 24V system

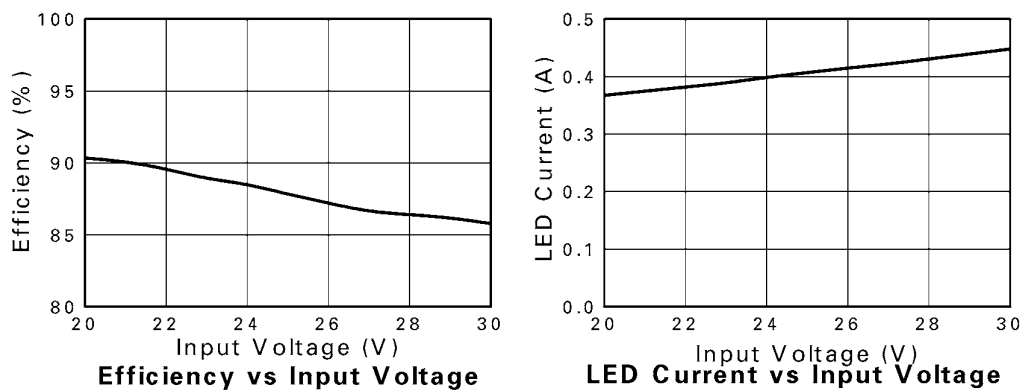

Figure 5 Performance graphs for 24V system

AN44

Useful formulae for calculations

The input power from the battery during T_{ON} (assuming discontinuous operation mode) is V_{IN} * I_{PEAK}/2. The average input current from the battery is therefore this current multiplied by the ratio of T_{ON} to the total cycle time:

$$\frac{I_{PEAK}}{2} \times \frac{T_{ON}}{T_{ON} + T_{OFF}}$$

It can be seen from this how the average battery current will increase at lower V_{IN} as T_{ON} becomes larger compared to the fixed 1.7µs T_{OFF}. This is logical, as the fixed (approximately) LED power will require more battery current at lower battery voltage to draw the same power.

The energy which is stored in the inductor equals the energy which is transferred from the inductor to the LED (assuming discontinuous operation) is:

$$\frac{1}{2} * L1 * I_{PEAK}^2 \text{ [Joules]}$$

$$T_{ON} = \frac{I_{PEAK} \times L1}{(V_{BATT} - V_{LED})}$$

Therefore, when the input and the output voltage difference are greater, the LED will have more energy which will be transferred from the inductor to the LED rather than be directly obtained from the battery. If the inductor size L1 and peak current I_{PEAK} can be calculated such that the current just reaches zero in 1.7µs, then the power in the LED will not be too dependent on battery volts, since the average current in the LED will always be approximately I_{PEAK}/2.

As the battery voltage increases, the T_{ON} necessary to reach I_{PEAK} will decrease, but the LED power will be substantially constant and it will just draw a battery current ramping from zero to I_{PEAK} during T_{ON}. At higher battery voltages, T_{ON} will have a lower proportional of the total cycle time, so that the average battery current at higher battery voltage will be less, such that power (and efficiency) is conserved.

The forward voltage which is across the Schottky diode detracts from the efficiency. For example, assuming V_F of the LED is 6V and V_F of the Schottky is 0.3V, the efficiency loss of energy which is transferred from the inductor is 5%, i.e. the ratio of the Schottky forward drop to the LED forward drop. The Schottky is not in circuit during the T_{ON} period and therefore does not cause a loss, so the overall percentage loss will depend on the ratio of the T_{ON} and T_{OFF} periods. For low battery voltages where T_{ON} is a large proportion of the cycle, the Schottky loss will not be significant. The Schottky loss will also be less significant at higher LED voltages (more LED's in series) as Schottky drop becomes a lower percentage of the total voltage.

Europe	Americas	Asia Pacific	Corporate Headquarters
Zetex GmbH Streitfeldstraße 19 D-81673 München Germany	Zetex Inc 700 Veterans Memorial Highway Hauppauge, NY 11788 USA	Zetex (Asia Ltd) 3701-04 Metroplaza Tower 1 Hing Fong Road, Kwai Fong Hong Kong	Zetex Semiconductors plc Zetex Technology Park, Chadderton Oldham, OL9 9LL United Kingdom
Telefon: (49) 89 45 49 49 0 Fax: (49) 89 45 49 49 49 europe.sales@zetex.com	Telephone: (1) 631 360 2222 Fax: (1) 631 360 8222 usa.sales@zetex.com	Telephone: (852) 26100 611 Fax: (852) 24250 494 asia.sales@zetex.com	Telephone: (44) 161 622 4444 Fax: (44) 161 622 4446 hq@zetex.com

For international sales offices visit www.zetex.com/offices

Zetex products are distributed worldwide. For details, see www.zetex.com/salesnetwork

This publication is issued to provide outline information only which (unless agreed by the company in writing) may not be used, applied or reproduced for any purpose or form part of any order or contact or be regarded as a representation relating to the products or services concerned. The company reserves the right to alter without notice the specification, design, price or conditions of supply of any product or service.
