

## Surface Mount LEDs, SOT-23 Package

|          | Line No. | Part No. | Lens  | Luminous Intensity at 20mA |         | Viewing Angle 2θ½ | Forward Voltage at 20mA |         | Peak Wave Length at 20mA | Drawing |
|----------|----------|----------|-------|----------------------------|---------|-------------------|-------------------------|---------|--------------------------|---------|
|          |          |          |       | Minimum                    | Typical |                   | Typical                 | Maximum |                          |         |
| ● RED    | 1        | E40      | Clear | 1.0mcd                     | 3.5mcd  | 140°              | 2.1V                    | 2.8V    | 635nm                    | A       |
| ● YELLOW | 2        | E41      | Clear | 1.0mcd                     | 3.0mcd  | 140°              | 2.1V                    | 2.8V    | 585nm                    | A       |
| ● GREEN  | 3        | E42      | Clear | 1.0mcd                     | 3.0mcd  | 140°              | 2.1V                    | 2.8V    | 565nm                    | A       |

Tape & Reel packaging is standard, 3,000 LEDs per reel  
Recommended soldering pad, see page 84, number 1

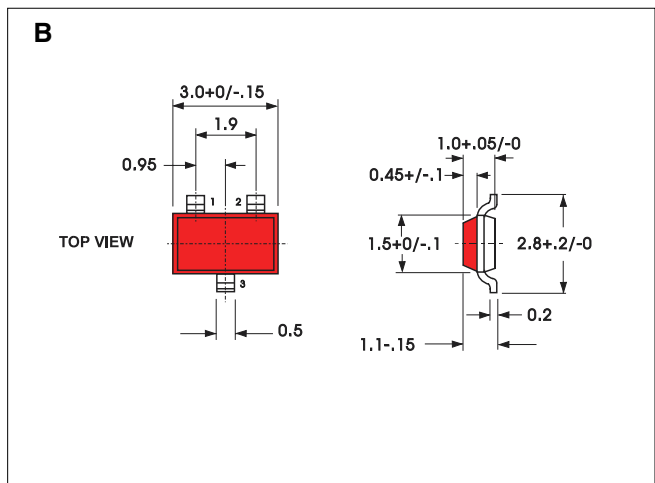

## Surface Mount, Bi-Color LEDs, SOT-23 Package

|                       | Line No. | Part No. | Luminous Intensity at 20mA |              | Viewing Angle 2θ½ | Forward Voltage at 20mA |              | Peak Wave Length at 20mA | Terminals                                      | Drawing |
|-----------------------|----------|----------|----------------------------|--------------|-------------------|-------------------------|--------------|--------------------------|--|---------|
|                       |          |          | Minimum                    | Typical      |                   | Typical                 | Maximum      |                          |  |         |
| ● RED &<br>● GREEN    | 4        | E43      | 1mcd<br>1mcd               | 3mcd<br>3mcd | 140°<br>140°      | 2.1V<br>2.2V            | 2.8V<br>2.5V | 635nm<br>565nm           | 1.Red Cathode<br>2.Green Cathode<br>3.Anode    | B       |
| ● RED &<br>● YELLOW   | 5        | E44      | 1mcd<br>1mcd               | 3mcd<br>3mcd | 140°<br>140°      | 2.1V<br>2.2V            | 2.8V<br>2.5V | 635nm<br>585nm           | 1.Red Cathode<br>2.Yellow Cathode<br>3.Anode   | B       |
| ● GREEN &<br>● YELLOW | 6        | E45      | 1mcd<br>1mcd               | 3mcd<br>3mcd | 140°<br>140°      | 2.1V<br>2.2V            | 2.8V<br>2.5V | 565nm<br>585nm           | 1.Yellow Cathode<br>2.Green Cathode<br>3.Anode | B       |

Tape & Reel packaging is standard, 3,000 LEDs per reel.  
Recommended soldering pad, see page 84, number 1

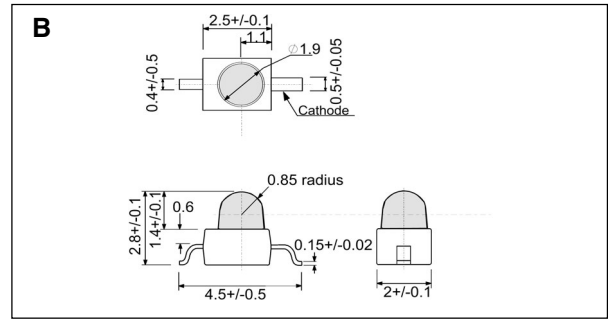
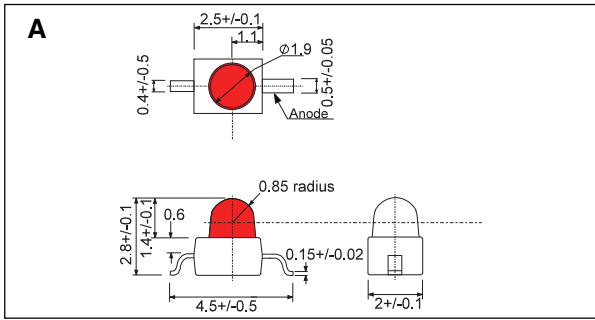

## Surface Mount, Gull Wing LEDs

|                       | Line No. | Part No. | Lens  | Luminous Intensity at 20mA |           | Viewing Angle 2θ½ | Forward Voltage at 20mA |         | Peak Wave Length at 20mA | Drawing |
|-----------------------|----------|----------|-------|----------------------------|-----------|-------------------|-------------------------|---------|--------------------------|---------|
|                       |          |          |       | Minimum                    | Maximum   |                   | Typical                 | Maximum |                          |         |
| ● ULTRA BRIGHT RED    | 1        | E90      | Clear | 200.0mcd                   | 1000.0mcd | 30°               | 1.85V                   | 2.50V   | 660nm                    | A       |
| ● HIGH EFFICIENCY RED | 2        | E91      | Clear | 20.0mcd                    | 100.0mcd  | 30°               | 2.00V                   | 2.50V   | 625nm                    | B       |
| ● YELLOW              | 3        | E92      | Clear | 20.0mcd                    | 70.0mcd   | 30°               | 2.10V                   | 2.50V   | 590nm                    | B       |
| ● ULTRA BRIGHT YELLOW | 4        | E95      | Clear | 700.0mcd                   | 1300.0mcd | 30°               | 2.00V                   | 2.50V   | 595nm                    | B       |
| ● GREEN               | 5        | E93      | Clear | 20.0mcd                    | 70.0mcd   | 30°               | 2.20V                   | 2.50V   | 565nm                    | B       |
| ● PURE GREEN          | 6        | E94      | Clear | 10.0mcd                    | 40.0mcd   | 30°               | 2.25V                   | 2.60V   | 555nm                    | B       |

Tape & Reel packaging is standard, 1,000 LEDs per reel.  
Recommended soldering pad, see page 84, number 2.

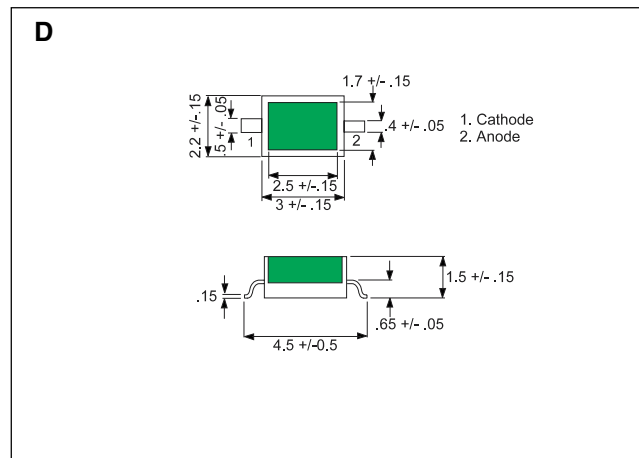
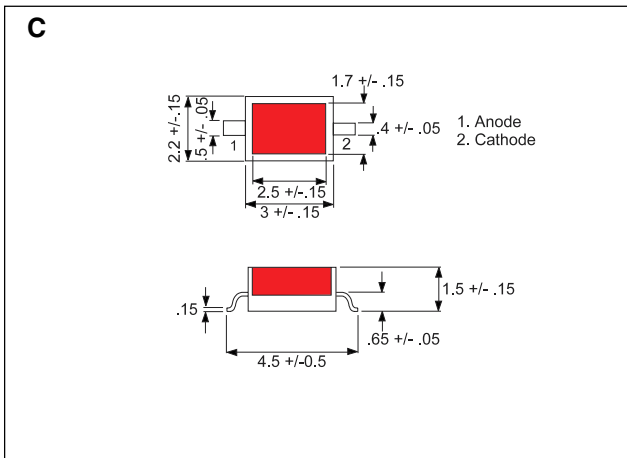

## Surface Mount LEDs (Rectangular Lens)

|                       | Line No. | Part No. | Lens               | Luminous Intensity at 20mA |         | Viewing Angle 2θ½ | Forward Voltage at 20mA |         | Peak Wave Length at 20mA | Drawing |
|-----------------------|----------|----------|--------------------|----------------------------|---------|-------------------|-------------------------|---------|--------------------------|---------|
|                       |          |          |                    | Minimum                    | Maximum |                   | Typical                 | Maximum |                          |         |
| ● ULTRA BRIGHT RED    | 7        | E80      | Translucent Red    | 70mcd                      | 100mcd  | 90°               | 1.85V                   | 2.50V   | 660nm                    | C       |
| ● HIGH EFFICIENCY RED | 8        | E81      | Translucent Red    | 12.5mcd                    | 20.0mcd | 90°               | 2.00V                   | 2.50V   | 625nm                    | D       |
| ● YELLOW              | 9        | E82      | Translucent Yellow | 5.0mcd                     | 20.0mcd | 90°               | 2.10V                   | 2.50V   | 590nm                    | D       |
| ● GREEN               | 10       | E83      | Translucent Green  | 8.0mcd                     | 20.0mcd | 90°               | 2.20V                   | 2.50V   | 565nm                    | D       |

Tape & Reel packaging is standard, 1500 LEDs per reel.  
Recommended soldering pad, page 84, number 3.

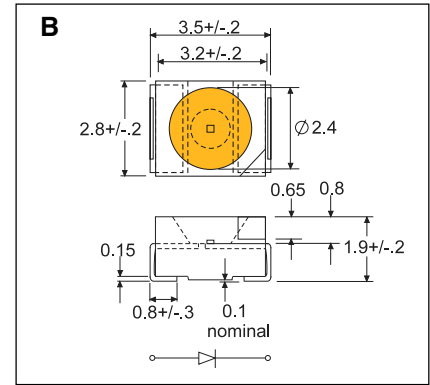
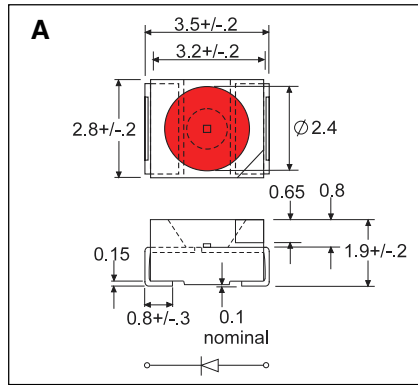

## Surface Mount LEDs (Round Lens)

|                       | Line No. | Part No. | Lens               | Luminous Intensity at 20mA |          | Viewing Angle 2θ½ | Forward Voltage at 20mA |         | Peak Wave Length at 20mA | Drawing |
|-----------------------|----------|----------|--------------------|----------------------------|----------|-------------------|-------------------------|---------|--------------------------|---------|
|                       |          |          |                    | Minimum                    | Maximum  |                   | Typical                 | Maximum |                          |         |
| ● ULTRA BRIGHT RED    | 1        | E70      | Translucent Red    | 80.0mcd                    | 120.0mcd | 120°              | 1.85V                   | 2.50V   | 660nm                    | A       |
| ● HIGH EFFICIENCY RED | 2        | E71      | Translucent Red    | 12.5mcd                    | 30.0mcd  | 120°              | 2.00V                   | 2.50V   | 625nm                    | B       |
| ● YELLOW              | 3        | E72      | Translucent Yellow | 8.0mcd                     | 20.0mcd  | 120°              | 2.10V                   | 2.50V   | 590nm                    | B       |
| ● GREEN               | 4        | E73      | Translucent Green  | 12.5mcd                    | 30.0mcd  | 120°              | 2.20V                   | 2.50V   | 565nm                    | B       |
| ● PURE GREEN          | 5        | E74      | Clear              | 2.0mcd                     | 8.0mcd   | 120°              | 2.25V                   | 2.60V   | 555nm                    | B       |
| ● BLUE                | 6        | E75      | Translucent Blue   | 2.0mcd                     | 5.0mcd   | 110°              | 4.5V                    | 5.5V    | 430nm                    | B       |
| ● ULTRA BRIGHT YELLOW | 7        | E77      | Translucent Yellow | 40.0mcd                    | 100mcd   | 120°              | 2.0V                    | 2.4V    | 595nm                    | B       |
| ● ORANGE              | 8        | E78      | Translucent Orange | 12.5mcd                    | 40.0mcd  | 120°              | 2.0V                    | 2.6V    | 610nm                    | B       |
| ● ULTRA BRIGHT ORANGE | 9        | E79      | Translucent Orange | 200mcd                     | 400mcd   | 120°              | 1.95V                   | 2.5V    | 620nm                    | B       |

Tape & Reel packaging is standard, 1500 LEDs per reel. Recommended Soldering Pad Page 84, number 4.

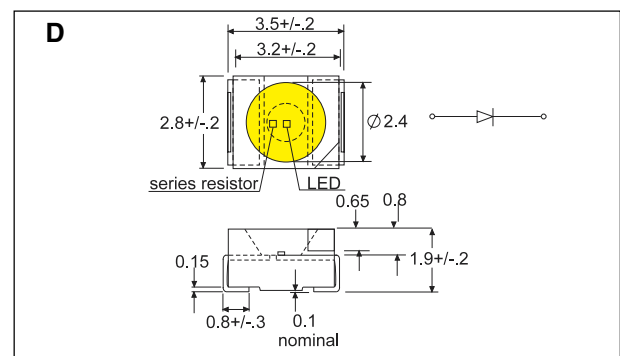
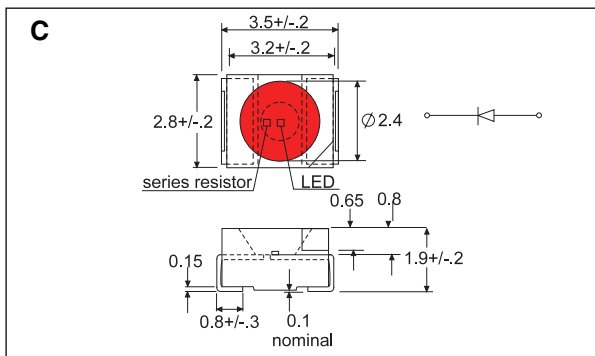

## Surface Mount LEDs with Resistor - 5V

|          | Line No. | Part No. | Lens        | Voltage Range |         | Luminous Intensity at 5VDC |         | Viewing Angle 2θ½ | Current Range at 5VDC |         | Peak Wave Length at 5VDC | Drawing |
|----------|----------|----------|-------------|---------------|---------|----------------------------|---------|-------------------|-----------------------|---------|--------------------------|---------|
|          |          |          |             | Minimum       | Maximum | Minimum                    | Maximum |                   | Minimum               | Maximum |                          |         |
| ● RED    | 10       | E70-5V   | Translucent | 4.0VDC        | 6.0VDC  | 20.0mcd                    | 80.0mcd | 120°              | 8mA                   | 16mA    | 660nm                    | C       |
| ● RED    | 11       | E71-5V   | Translucent | 4.0VDC        | 6.0VDC  | 5.0mcd                     | 20.0mcd | 120°              | 8mA                   | 16mA    | 625nm                    | D       |
| ● YELLOW | 12       | E72-5V   | Translucent | 4.0VDC        | 6.0VDC  | 3.2mcd                     | 8.0mcd  | 120°              | 8mA                   | 16mA    | 590nm                    | D       |
| ● GREEN  | 13       | E73-5V   | Translucent | 4.0VDC        | 6.0VDC  | 5.0mcd                     | 12.5mcd | 120°              | 8mA                   | 16mA    | 565nm                    | D       |

Tape & Reel packaging is standard, 1500 LEDs per reel. Recommended soldering pad, page 84, number 4.

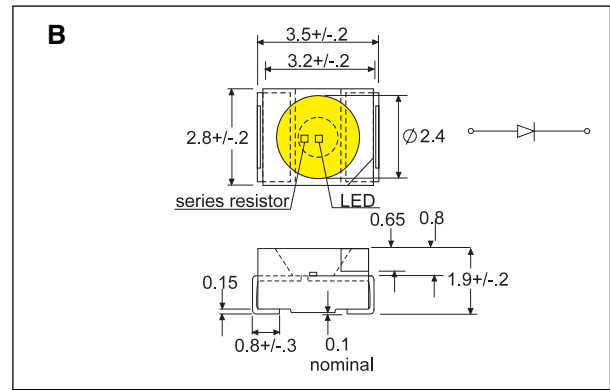
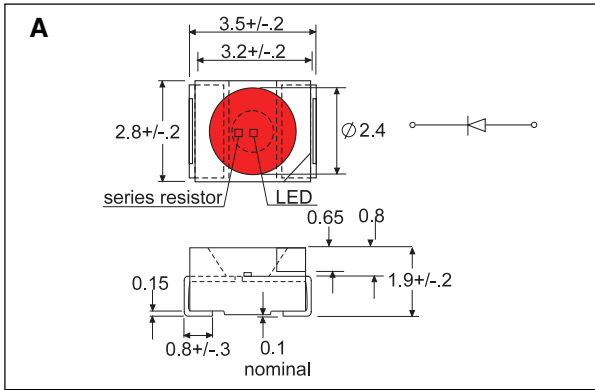

## Surface Mount LEDs with Resistor - 12V

| Line No. | Part No. | Lens    | Voltage Range |         | Luminous Intensity at 12VDC |         | Viewing Angle 2θ½ | Current Range at 12VDC |         | Peak Wave Length at 12VDC | Drawing |   |
|----------|----------|---------|---------------|---------|-----------------------------|---------|-------------------|------------------------|---------|---------------------------|---------|---|
|          |          |         | Minimum       | Maximum | Minimum                     | Maximum |                   | Minimum                | Maximum |                           |         |   |
| ● RED    | 1        | E70-12V | Translucent   | 9.5VDC  | 13.0VDC                     | 20.0mcd | 80.0mcd           | 120°                   | 8mA     | 16mA                      | 660nm   | A |
| ● RED    | 2        | E71-12V | Translucent   | 9.5VDC  | 13.0VDC                     | 5.0mcd  | 20.0mcd           | 120°                   | 8mA     | 16mA                      | 625nm   | B |
| ● YELLOW | 3        | E72-12V | Translucent   | 9.5VDC  | 13.0VDC                     | 3.2mcd  | 8.0mcd            | 120°                   | 8mA     | 16mA                      | 590nm   | B |
| ● GREEN  | 4        | E73-12V | Translucent   | 9.5VDC  | 13.0VDC                     | 5.0mcd  | 12.5mcd           | 120°                   | 8mA     | 16mA                      | 565nm   | B |

Tape & Reel packaging is standard, 1500 LEDs per reel.  
Recommended soldering pad, page 84, number 4.

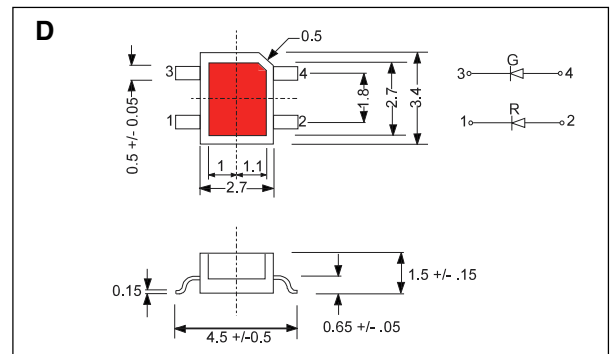
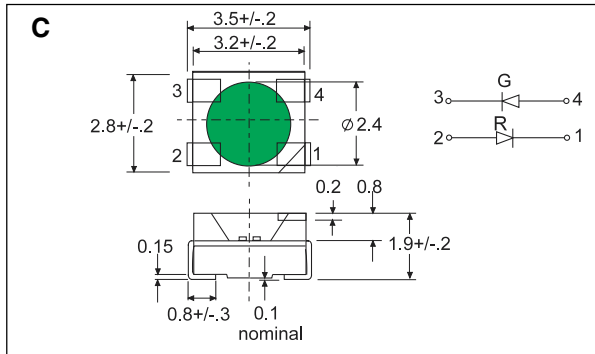

## Surface Mount, Bi-Color LEDs

| Line No.           | Part No. | Lens | Luminous Intensity at 20mA |                    | Viewing Angle 2θ½ | Forward Voltage at 20mA |              | Peak Wave Length at 20mA | Leads  | Drawing |
|--------------------|----------|------|----------------------------|--------------------|-------------------|-------------------------|--------------|--------------------------|--|---------|
|                    |          |      | Minimum                    | Maximum            |                   | Typical                 | Maximum      |                          |  |         |
| ● RED &<br>● GREEN | 5        | E76  | Clear                      | 12.5mcd<br>32.0mcd | 120°<br>120°      | 2.0V<br>2.2V            | 2.5V<br>2.5V | 625nm<br>565nm           | 1.Red Cathode<br>2.Red Anode<br>3.Green Cathode<br>4.Green Anode | C       |
| ● RED &<br>● GREEN | 6        | E86  | White Diffused             | 8.0mcd<br>8.0mcd   | 90°<br>90°        | 2.0V<br>2.2V            | 2.5V<br>2.5V | 625nm<br>565nm           | 1.Red Cathode<br>2.Red Anode<br>3.Green Cathode<br>4.Green Anode | D       |

Tape & Reel packaging is standard, 1500 LEDs (E76), 1000 LEDs (E86), per reel.  
Recommended soldering pad: E76 - page 84, number 5; E86 - page 84, number 6.

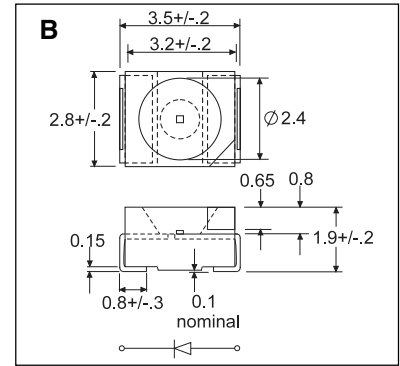
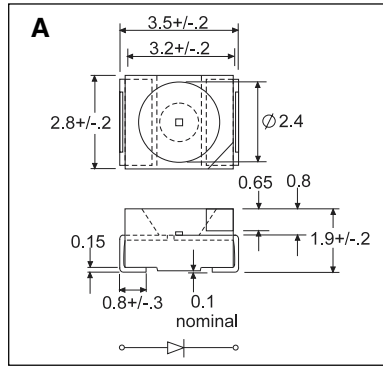

## Surface Mount Infrared LEDs: 880nm, 940nm

| Line No. | Part No. | Lens | Radiant Power at 20mA |           | Viewing Angle 20½° | Forward Voltage at 20mA |         | Peak Wave Length at 20mA | Drawing |   |
|----------|----------|------|-----------------------|-----------|--------------------|-------------------------|---------|--------------------------|---------|---|
|          |          |      | Minimum               | Maximum   |                    | Typical                 | Maximum |                          |         |   |
| INFRARED | 1        | E25A | Clear                 | 1.25mW/sr | 5.0mW/sr           | 120°                    | 1.2V    | 1.5V                     | 940nm   | A |
| INFRARED | 2        | E26A | Translucent Blue      | 1mW/sr    | 5.0mW/sr           | 120°                    | 1.4V    | 1.7V                     | 880nm   | B |

Tape & Reel packaging is standard, 1,500 LEDs per reel.  
 Recommended soldering pad, see page 84, number 4.

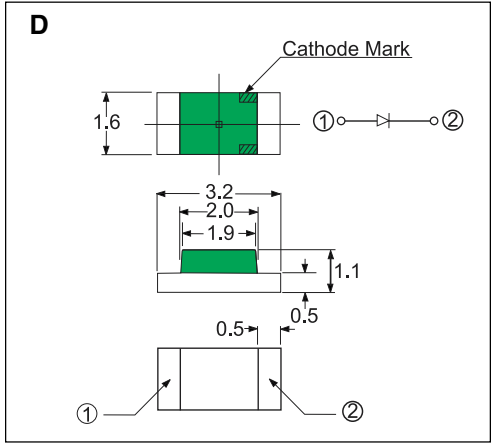
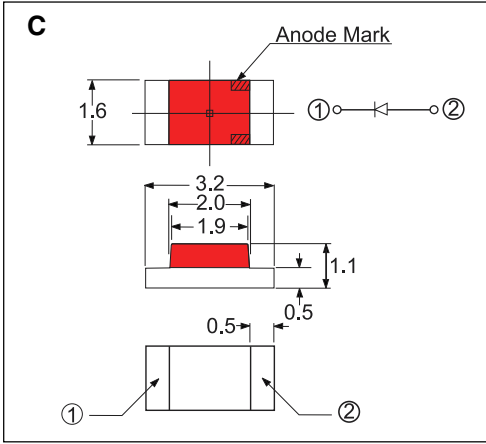

## Low Profile Surface Mount LEDs (standard package 0603)

| Line No.              | Part No. | Lens | Luminous Intensity at 20mA |         | Viewing Angle 20½° | Forward Voltage at 20mA |         | Peak Wave Length at 20mA | Drawing |   |
|-----------------------|----------|------|----------------------------|---------|--------------------|-------------------------|---------|--------------------------|---------|---|
|                       |          |      | Minimum                    | Maximum |                    | Typical                 | Maximum |                          |         |   |
| ● ULTRA BRIGHT RED    | 3        | E510 | Translucent Red            | 40.0mcd | 70.0mcd            | 120°                    | 1.85V   | 2.50V                    | 660nm   | C |
| ● HIGH EFFICIENCY RED | 4        | E511 | Translucent Red            | 5.0mcd  | 12.0mcd            | 120°                    | 2.00V   | 2.50V                    | 625nm   | D |
| ● YELLOW              | 5        | E512 | Translucent Yellow         | 3.2mcd  | 8.0mcd             | 120°                    | 2.10V   | 2.50V                    | 590nm   | D |
| ● GREEN               | 6        | E513 | Translucent Green          | 3.2mcd  | 8.0mcd             | 120°                    | 2.20V   | 2.50V                    | 565nm   | D |

Tape & Reel packaging is standard, 2000 LEDs per reel.  
 Recommended Soldering Pad Page 84, number 7 .

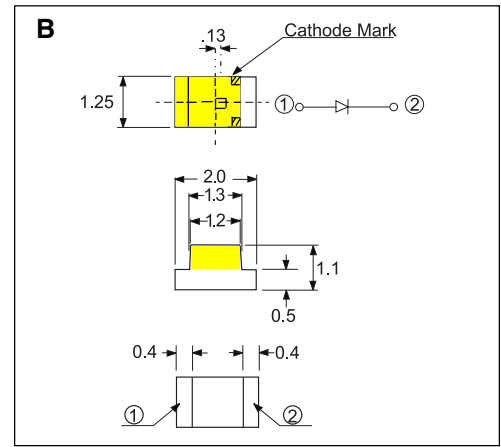
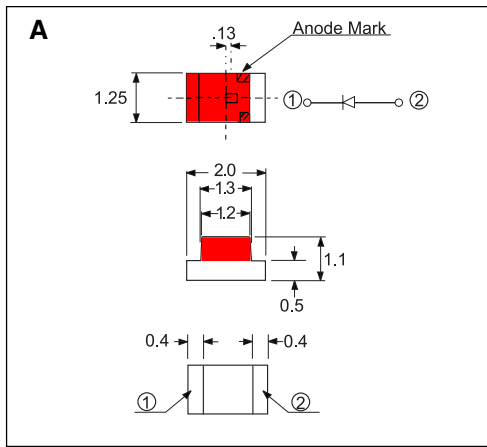

## Low Profile Surface Mount LEDs (standard package 0805)

|                       | Line No. | Part No. | Lens               | Luminous Intensity at 20mA |         | Viewing Angle 2θ½ | Forward Voltage at 20mA |         | Peak Wave Length at 20mA | Drawing |
|-----------------------|----------|----------|--------------------|----------------------------|---------|-------------------|-------------------------|---------|--------------------------|---------|
|                       |          |          |                    | Minimum                    | Maximum |                   | Typical                 | Maximum |                          |         |
| ● ULTRA BRIGHT RED    | 1        | E520     | Translucent Red    | 40.0mcd                    | 70.0mcd | 120°              | 1.85V                   | 2.50V   | 660nm                    | A       |
| ● HIGH EFFICIENCY RED | 2        | E521     | Translucent Red    | 5.0mcd                     | 12.0mcd | 120°              | 2.00V                   | 2.50V   | 625nm                    | B       |
| ● YELLOW              | 3        | E522     | Translucent Yellow | 3.2mcd                     | 8.0mcd  | 120°              | 2.10V                   | 2.50V   | 590nm                    | B       |
| ● GREEN               | 4        | E523     | Translucent Green  | 3.2mcd                     | 8.0mcd  | 120°              | 2.20V                   | 2.50V   | 565nm                    | B       |

Tape & Reel packaging is standard, 2000 LEDs per reel.  
Recommended Soldering Pad Page 84, number 8.

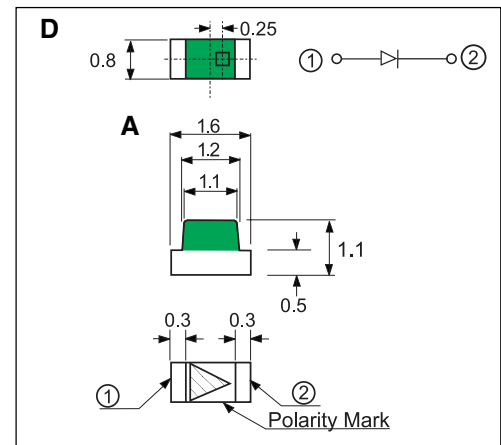
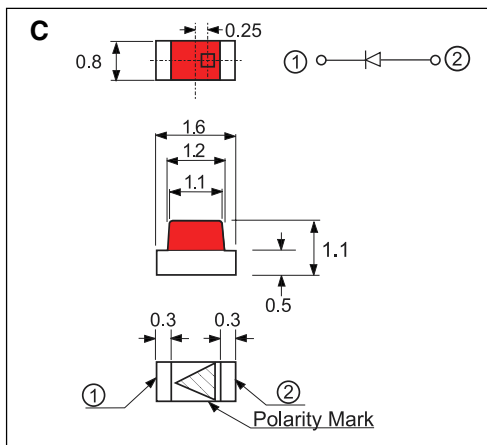

## Low Profile Surface Mount LEDs (standard package 1206)

|                       | Line No. | Part No. | Lens               | Luminous Intensity at 20mA |         | Viewing Angle 2θ½ | Forward Voltage at 20mA |         | Peak Wave Length at 20mA | Drawing |
|-----------------------|----------|----------|--------------------|----------------------------|---------|-------------------|-------------------------|---------|--------------------------|---------|
|                       |          |          |                    | Minimum                    | Maximum |                   | Typical                 | Maximum |                          |         |
| ● ULTRA BRIGHT RED    | 5        | E530     | Translucent Red    | 40.0mcd                    | 70.0mcd | 120°              | 1.85V                   | 2.50V   | 660nm                    | C       |
| ● HIGH EFFICIENCY RED | 6        | E531     | Translucent Red    | 5.0mcd                     | 12.0mcd | 120°              | 2.00V                   | 2.50V   | 625nm                    | D       |
| ● YELLOW              | 7        | E532     | Translucent Yellow | 3.2mcd                     | 8.0mcd  | 120°              | 2.10V                   | 2.50V   | 590nm                    | D       |
| ● GREEN               | 8        | E533     | Translucent Green  | 3.2mcd                     | 8.0mcd  | 120°              | 2.20V                   | 2.50V   | 565nm                    | D       |

Tape & Reel packaging is standard, 2000 LEDs per reel.  
Recommended Soldering Pad Page 84, number 9.

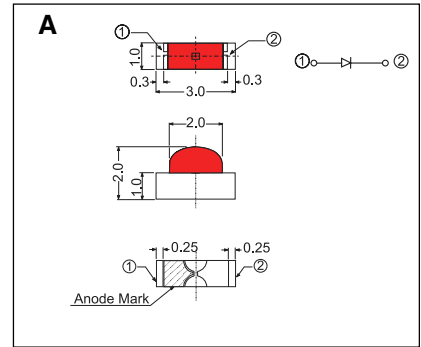

## Right Angle/Side Lighting Surface Mount LEDs

|                       | Line No. | Part No. | Lens               | Luminous Intensity at 20mA |         | Viewing Angle 2θ½ | Forward Voltage at 20mA |         | Peak Wave Length at 20mA | Drawing |
|-----------------------|----------|----------|--------------------|----------------------------|---------|-------------------|-------------------------|---------|--------------------------|---------|
|                       |          |          |                    | Minimum                    | Maximum |                   | Typical                 | Maximum |                          |         |
| ● ULTRA BRIGHT RED    | 1        | E540     | Translucent Red    | 40.0mcd                    | 70.0mcd | 120°              | 1.85V                   | 2.50V   | 660nm                    | A       |
| ● HIGH EFFICIENCY RED | 2        | E541     | Translucent Red    | 5.0mcd                     | 12.0mcd | 120°              | 2.00V                   | 2.50V   | 625nm                    | A       |
| ● YELLOW              | 3        | E542     | Translucent Yellow | 3.2mcd                     | 8.0mcd  | 120°              | 2.10V                   | 2.50V   | 590nm                    | A       |
| ● GREEN               | 4        | E543     | Translucent Green  | 3.2mcd                     | 12.5mcd | 120°              | 2.20V                   | 2.50V   | 565nm                    | A       |

Tape & Reel packaging is standard, 2000 LEDs per reel.  
Recommended Soldering Pad Page 84, number 10.

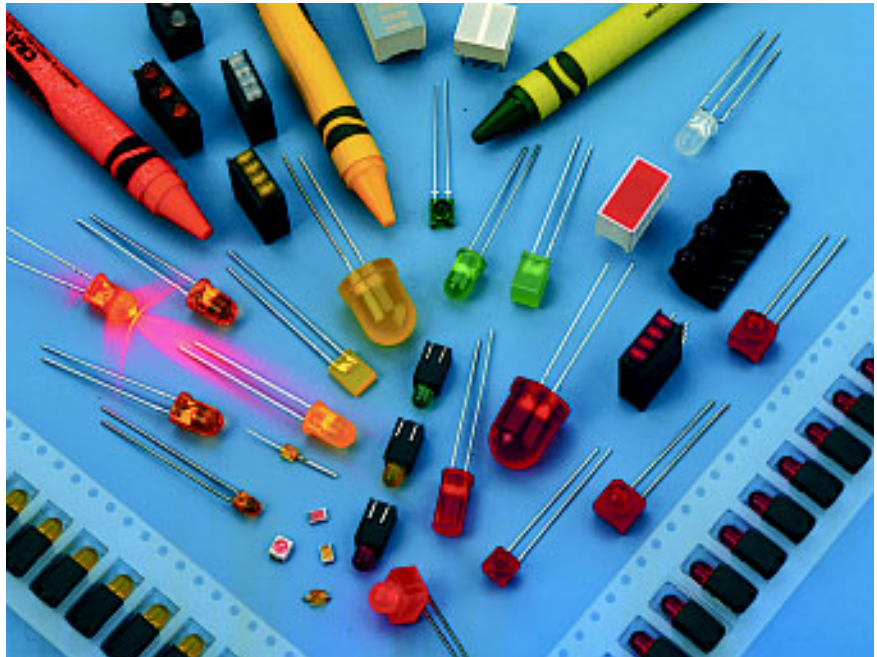

Telephone: 781-935-4442  
Fax: 781-938-5867

sales@gilway.com  
www.gilway.com

**Gilway**  
Technical Lamp  
Engineering Catalog 169

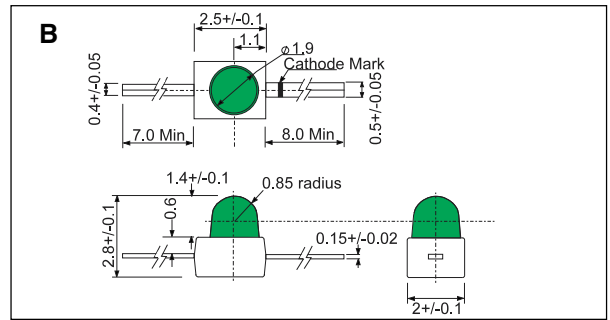
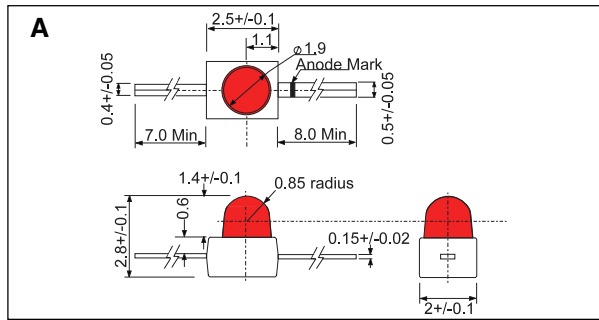

## Axial Lead LEDs

|                       | Line No. | Part No. | Lens               | Luminous Intensity at 20mA |           | Viewing Angle 2θ½ | Forward Voltage at 20mA |         | Peak Wave Length at 20mA | Drawing |
|-----------------------|----------|----------|--------------------|----------------------------|-----------|-------------------|-------------------------|---------|--------------------------|---------|
|                       |          |          |                    | Minimum                    | Maximum   |                   | Typical                 | Maximum |                          |         |
| ● ULTRA BRIGHT RED    | 1        | E36A     | Translucent Red    | 200.0mcd                   | 1000.0mcd | 30°               | 1.85V                   | 2.50V   | 660nm                    | A       |
| ● HIGH EFFICIENCY RED | 2        | E39A     | Translucent Red    | 20.0mcd                    | 100.0mcd  | 30°               | 2.00V                   | 2.50V   | 625nm                    | B       |
| ● YELLOW              | 3        | E37A     | Translucent Yellow | 20.0mcd                    | 70.0mcd   | 30°               | 2.10V                   | 2.50V   | 590nm                    | B       |
| ● ULTRA BRIGHT YELLOW | 4        | E37B     | Translucent Yellow | 700.0mcd                   | 1300mcd   | 30°               | 2.00V                   | 2.50V   | 595nm                    | B       |
| ● GREEN               | 5        | E38A     | Translucent Green  | 20.0mcd                    | 70.0mcd   | 30°               | 2.20V                   | 2.50V   | 565nm                    | B       |