



# VN540 / VN540SP VN540(011Y) / VN540(012Y)

## HIGH SIDE SMART POWER SOLID STATE RELAY

TYPE	V <sub>demag</sub>	R <sub>DS(on)</sub>	I <sub>OUT</sub>	V <sub>CC</sub>
VN540 VN540SP VN540(011Y) VN540(012Y)	-55V	50mΩ	2.8A	36 V

- OUTPUT CURRENT (CONTINUOUS): 2.8A
- DIGITAL INPUT CLAMPED AT 32V
- PROTECTION AGAINST: LOSS OF GROUND, SHORTED LOAD AND OVERTEMPERATURE
- BUILT-IN CURRENT LIMITER
- UNDER VOLTAGE SHUT DOWN
- OPEN DRAIN DIAGNOSTIC OUTPUT
- FAST DEMAGNETIZATION OF INDUCTIVE LOADS.

### DESCRIPTION

The VN540, VN540SP, VN540(011Y), VN540(012Y) is a monolithic device designed in STMicroelectronics VIPower technology, intended for driving resistive or inductive loads with one side connected to ground. Active current limitation avoids the system power supply dropping in case of shorted load. Built-in thermal shut down protects the chip from over temperature. The open drain diagnostic output indicates over temperature conditions.

### BLOCK DIAGRAM

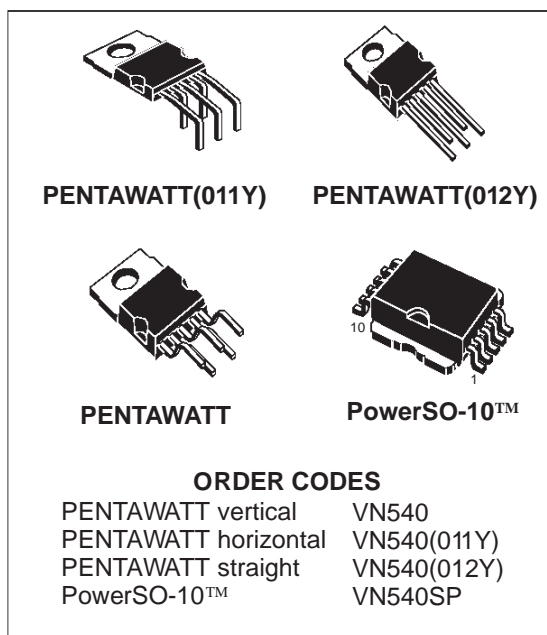
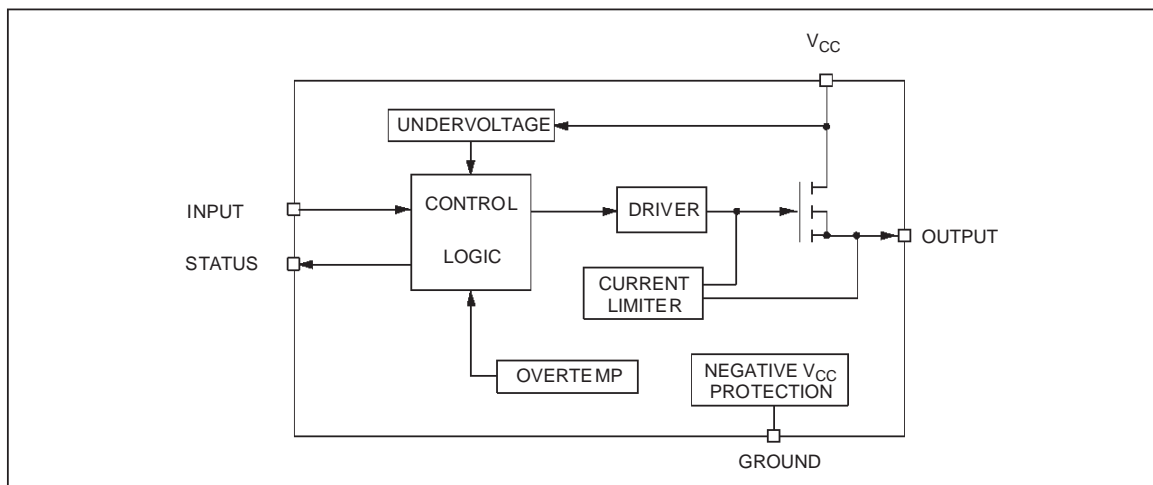

**ABSOLUTE MAXIMUM RATING**

Symbol	Parameter	Value	Unit
$V_{CC}$	Power supply voltage	45	V
$-V_{CC}$	Reverse supply voltage	-4.0	V
$I_{OUT}$	Maximum DC load current	Internally limited	A
$I_R$	Reverse output current	-10	A
$I_{IN}$	Input current	+/- 10	mA
$I_{STAT}$	Status pin current	+/- 10	mA
$V_{ESD}$	Electrostatic discharge (R=1.5k $\Omega$ , C=100pF)	2000	V
$P_{TOT}$	Power dissipation at T <sub>c</sub> =25°C	Internally limited	W
T <sub>j</sub>	Junction operating temperature	Internally limited	°C
T <sub>STG</sub>	Storage temperature	-55 to 150	°C
E <sub>AS</sub>	Single pulse avalanche energy	500	mJ

**CONNECTION DIAGRAM TOP VIEW**

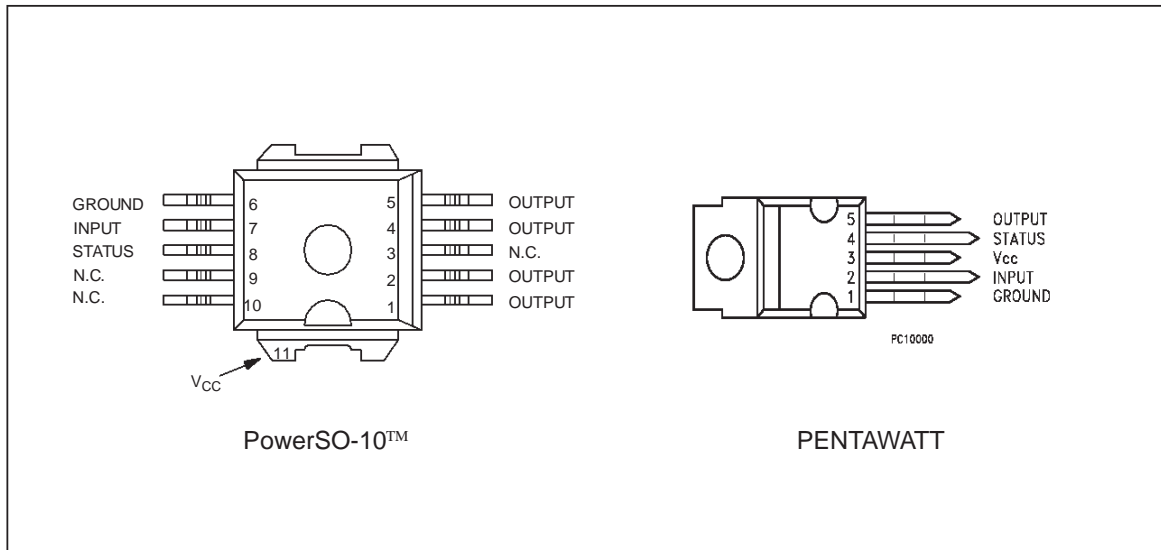

**CURRENT AND VOLTAGE CONVENTIONS**

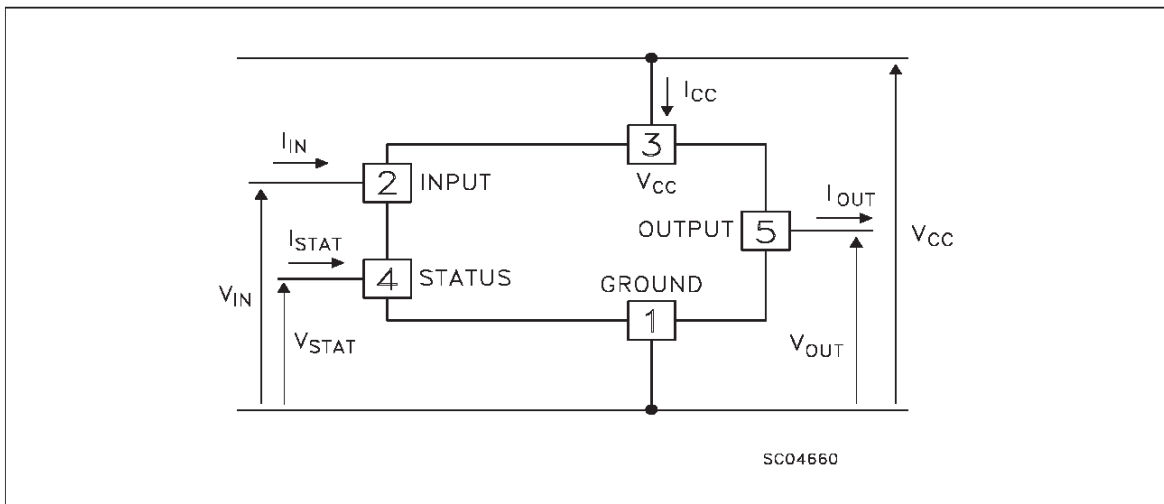

**THERMAL DATA**

Symbol	Parameter	Value		Unit
		PowerSO-10	PENTAWATT	
R <sub>thj-case</sub>	Thermal resistance junction-case (MAX)	1.5	2.0	°C/W
R <sub>thj-amb</sub>	Thermal resistance junction-ambient (MAX)	50	60	°C/W

**ELECTRICAL CHARACTERISTICS** (10V<V<sub>CC</sub><36V; -25°C<T<sub>j</sub><100°C; unless otherwise specified)

**POWER**

Symbol	Parameter	Test Conditions	Min	Typ	Max	Unit
V <sub>CC</sub>	Operating voltage		10		36	V
R <sub>ON</sub>	On state resistance	I <sub>OUT</sub> =2.8A; T <sub>j</sub> =25°C			50	mΩ
		I <sub>OUT</sub> =2.8A;			90	mΩ
I <sub>S</sub>	Supply current	OFF state			1	mA
		ON state (T <sub>j</sub> =125°C)			3	mA
		I <sub>OUT</sub> =0A				
I <sub>LS</sub>	Output leakage current	Channel OFF			100	μA
		V <sub>CC</sub> =45V				
I <sub>LGND</sub>	Output current at turn-off	V <sub>CC</sub> =V <sub>IN</sub> =V <sub>GND</sub> =V <sub>STAT</sub> =24V			2	mA
		T <sub>j</sub> = -25°C<T <sub>j</sub> <100°C				
V <sub>OL</sub>	Low state output voltage	V <sub>IN</sub> =V <sub>IL</sub> ; R <sub>LOAD</sub> ≥10MΩ			1.5	V
V <sub>demag</sub>	Output voltage at turn-off	I <sub>OUT</sub> =2.8A; L <sub>LOAD</sub> =1mH	V <sub>CC</sub> -65	V <sub>CC</sub> -55	V <sub>CC</sub> -45	V

**SWITCHING**

Symbol	Parameter	Test Conditions	Min	Typ	Max	Unit
t <sub>d(on)</sub>	Turn-on delay on output current	I <sub>OUT</sub> =2.8A; Resistive Load Input rise time <0.1μs; V <sub>CC</sub> =24V; T <sub>j</sub> =25°C		40		μs
t <sub>r</sub>	Rise time of output current	I <sub>OUT</sub> =2.8A; Resistive Load Input rise time <0.1μs; V <sub>CC</sub> =24V; T <sub>j</sub> =25°C		60		μs
t <sub>d(off)</sub>	Turn-off delay on output current	I <sub>OUT</sub> =2.8A; Resistive Load Input rise time <0.1μs; V <sub>CC</sub> =24V; T <sub>j</sub> =25°C		60		μs
t <sub>f</sub>	Fall time of output current	I <sub>OUT</sub> =2.8A; Resistive Load Input rise time <0.1μs; V <sub>CC</sub> =24V; T <sub>j</sub> =25°C		25		μs
dI/dt <sub>(on)</sub>	Turn-on current average slope	I <sub>OUT</sub> =2.8A I <sub>OUT</sub> =I <sub>LIM</sub> ; 25°C<T <sub>j</sub> <140°C			0.5	A/μs
					2	A/μs
dI/dt <sub>(off)</sub>	Turn-off current average slope	I <sub>OUT</sub> =2.8A I <sub>OUT</sub> =I <sub>LIM</sub> ; 25°C<T <sub>j</sub> <140°C			2	A/μs
					4	A/μs

**LOGIC INPUT**

Symbol	Parameter	Test Conditions	Min	Typ	Max	Unit
V <sub>IL</sub>	Input low level voltage				2.0	V
V <sub>IH</sub>	Input high level voltage		3.5			V
V <sub>I(hyst)</sub>	Input hysteresis voltage			0.5		V
I <sub>IN</sub>	Input current	V <sub>IN</sub> =30V			300	μA
		V <sub>IN</sub> =2.0V	25			μA
V <sub>ICL</sub>	Input clamp voltage (see note 1)	I <sub>IN</sub> =1mA	32	36		V
		I <sub>IN</sub> =-1mA		-0.7		V

PROTECTIONS AND DIAGNOSTICS

Symbol	Parameter	Test Conditions	Min	Typ	Max	Unit
$V_{STAT}$	Status output voltage	$I_{STAT}=5mA$ (Fault condition)			1	V
$V_{SCL} (*)$	Status clamp voltage	$I_{STAT}=1mA$ $I_{STAT}=-1mA$	32	36 0.7		V V
$I_{STAT}$	Leakage on diagnostic pin in high state	$V_{STAT}=5V$			10	$\mu A$
$V_{USD}$	Undervoltage shut-down		5.0		8.0	V
$I_{LIM}$	DC short circuit current	$V_{CC}=24V, R_{LOAD}<0.1\Omega$	2.8	5.0	8.0	A
$t_{SC}$	Delay time of current limiter				100	$\mu s$
$T_{TSD}$	Thermal shut-down temperature		150	170		$^{\circ}C$
$T_R$	Thermal reset temperature		135	155		$^{\circ}C$

(\*) Status determination > 100 $\mu s$  after the switching edge.

SWITCHING CHARACTERISTICS

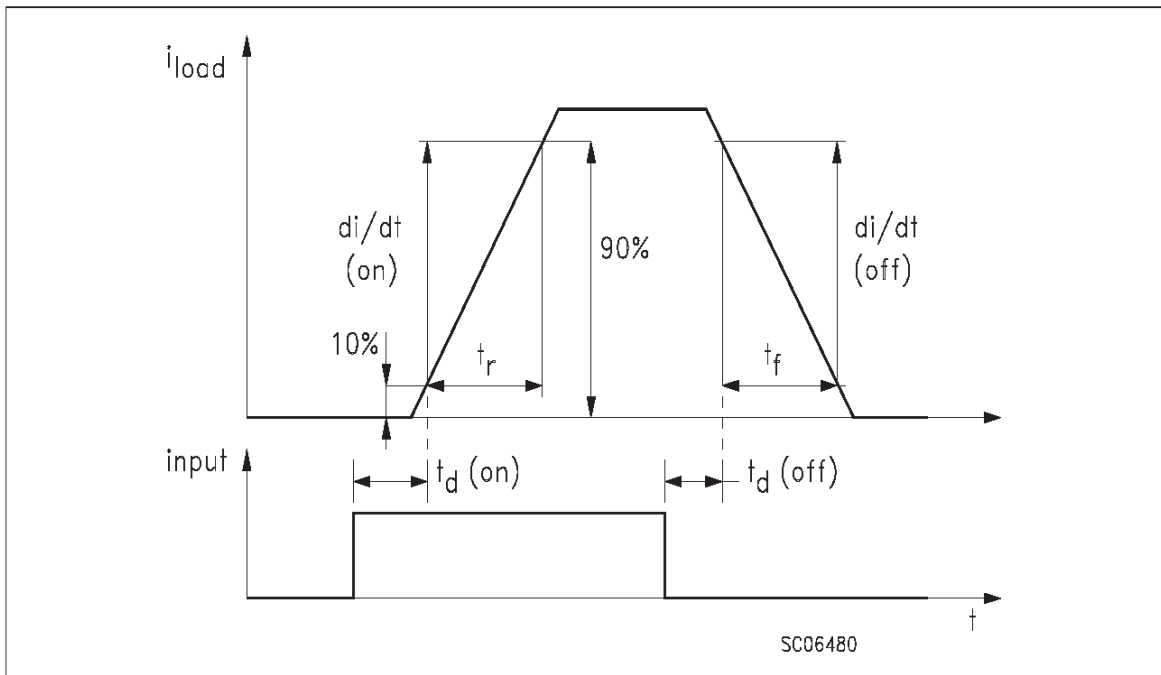

Note 1: The input voltage is internally clamped at 32V minimum, it is possible to connect the input pins to an higher voltage via an external resistor calculate to not exceed 10mA.

Note 2: If INPUT pin is floating the corresponding channel will automatically switch off. If GND pin is disconnected, the channel will switch off provided  $V_{CC}$  not exceed 36V.

**THRUTH TABLE**

	INPUT	OUTPUT	STATUS
Normal operation	L	L	H
	H	H	H
Overtemperature	L	L	H
	H	L	L
Undervoltage	L	L	H
	H	L	H
Shorted load (Current limitation)	L	L	H
	H	H	H

**Fig. 1: Peak Short Test Circuit**

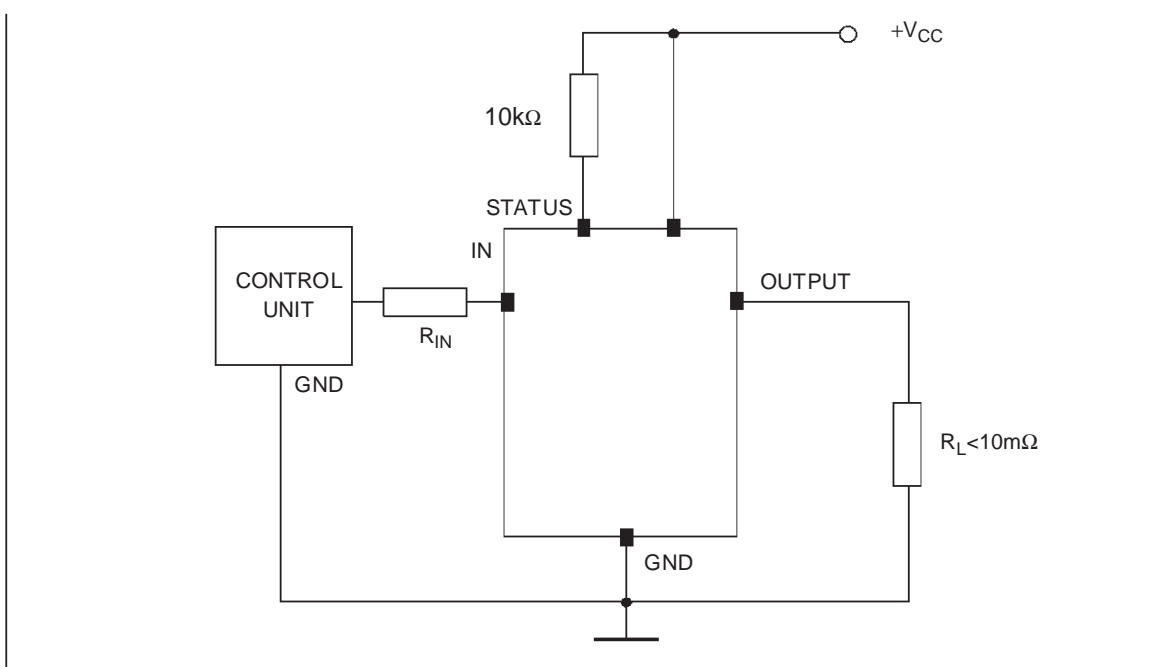

Figure 2: Waveforms

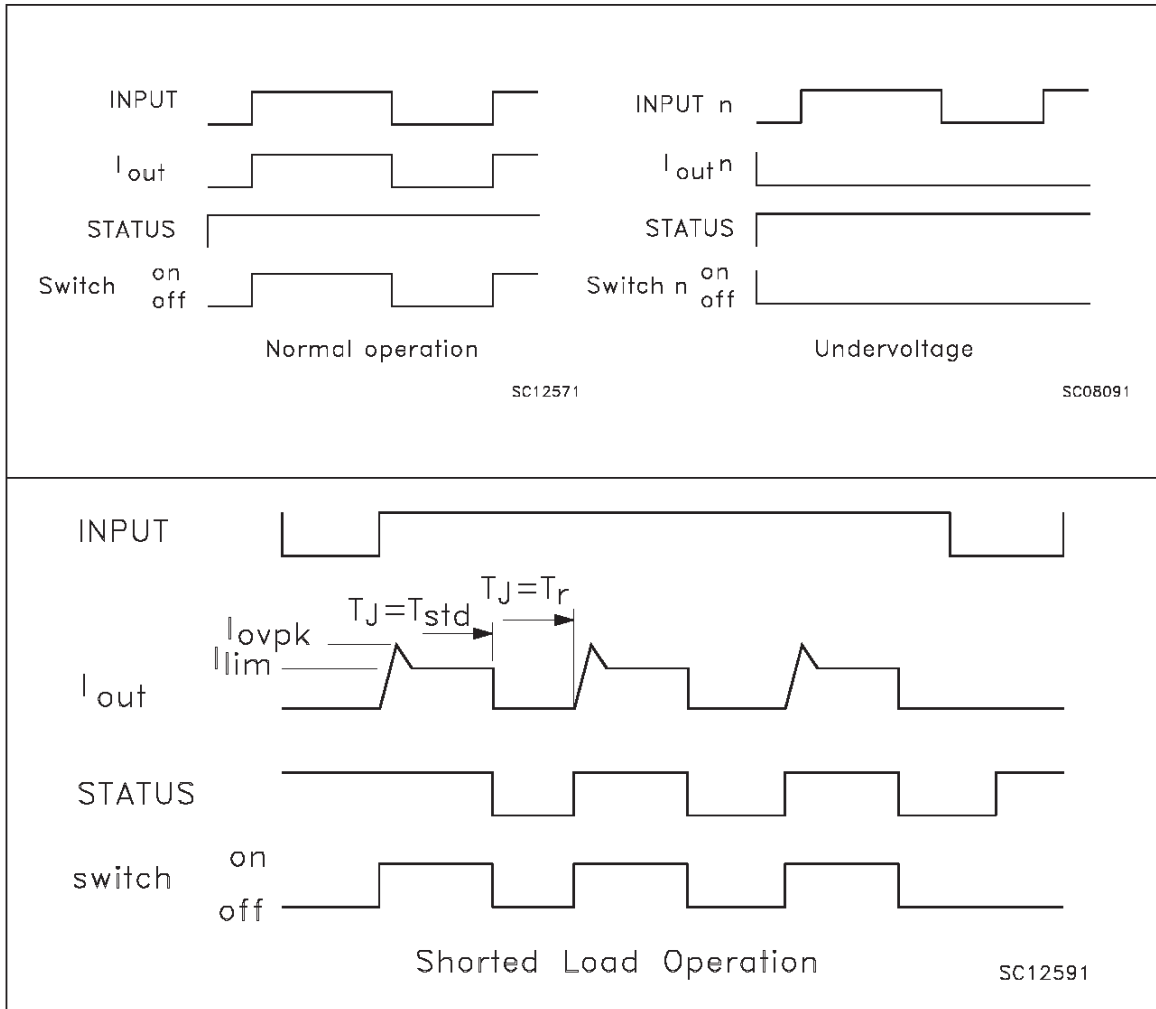
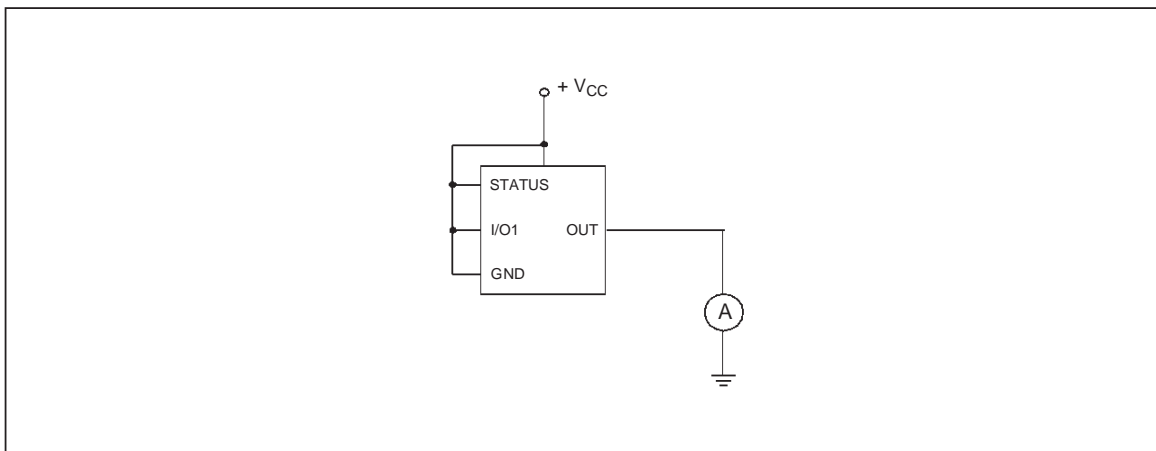
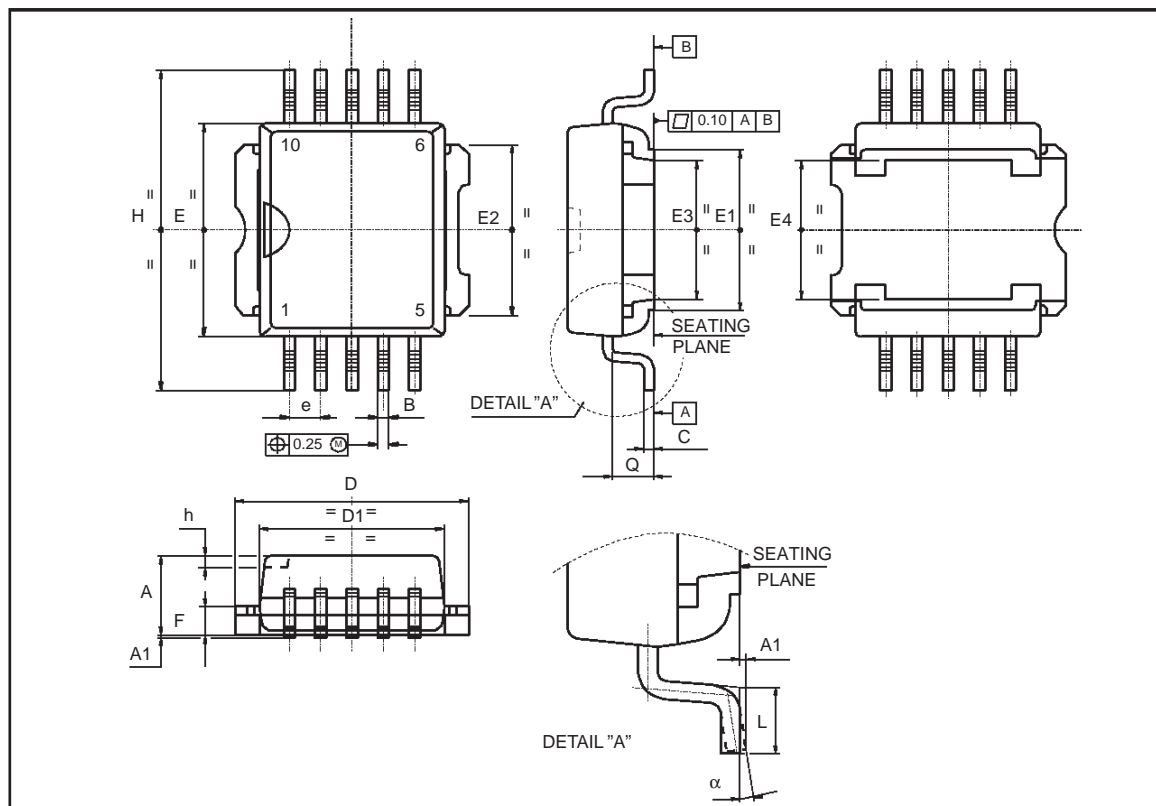

Fig. 3: I<sub>LGND</sub> Test Configuration



**PowerSO-10™ MECHANICAL DATA**

DIM.	mm.			inch		
	MIN.	TYP	MAX.	MIN.	TYP.	MAX.
A	3.35		3.65	0.132		0.144
A1	0.00		0.10	0.000		0.004
B	0.40		0.60	0.016		0.024
c	0.35		0.55	0.013		0.022
D	9.40		9.60	0.370		0.378
D1	7.40		7.60	0.291		0.300
E	9.30		9.50	0.366		0.374
E1	7.20		7.40	0.283		0.291
E2	7.20		7.60	0.283		300
E3	6.10		6.35	0.240		0.250
E4	5.90		6.10	0.232		0.240
e		1.27			0.050	
F	1.25		1.35	0.049		0.053
H	13.80		14.40	0.543		0.567
h		0.50			0.002	
Q		1.70			0.067	
$\alpha$	0°		8°			



**PENTAWATT (IN-LINE) MECHANICAL DATA**

DIM.	mm.			inch		
	MIN.	TYP	MAX.	MIN.	TYP.	MAX.
A			4.8			0.189
C			1.37			0.054
D	2.4		2.8	0.094		0.110
D1	1.2		1.35	0.047		0.053
E	0.35		0.55	0.014		0.022
F	0.8		1.05	0.031		0.041
F1	1		1.4	0.039		0.055
G	3.2	3.4	3.6	0.126	0.134	0.142
G1	6.6	6.8	7	0.260	0.268	0.276
H2			10.4			0.409
H3	10.05		10.4	0.396		0.409
L2	23.05	23.4	23.8	0.907	0.921	0.937
L3	25.3	25.65	26.1	0.996	1.010	1.028
L5	2.6		3	0.102		0.118
L6	15.1		15.8	0.594		0.622
L7	6		6.6	0.236		0.260
Diam.	3.65		3.85	0.144		0.152

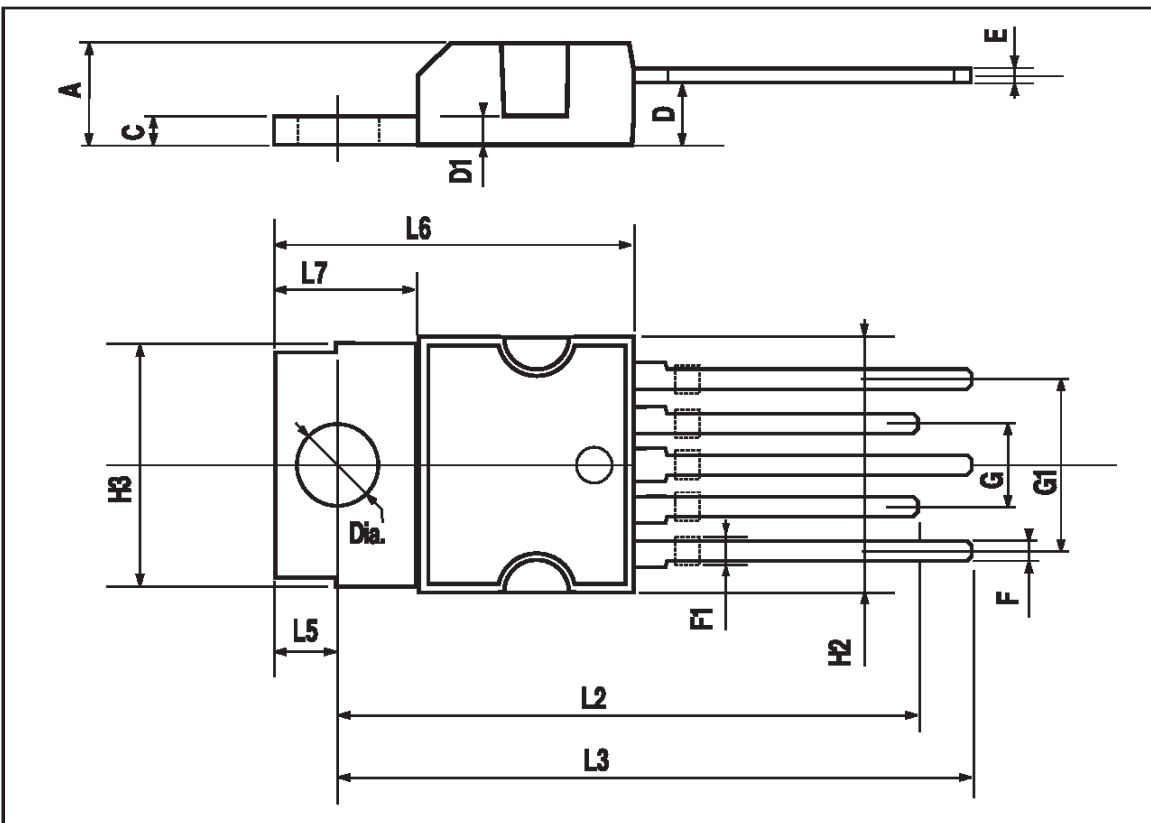



**PENTAWATT (HORIZONTAL) MECHANICAL DATA**

DIM.	mm.			inch		
	MIN.	TYP	MAX.	MIN.	TYP.	MAX.
A			4.8			0.189
C			1.37			0.054
D	2.4		2.8	0.094		0.110
D1	1.2		1.35	0.047		0.053
E	0.35		0.55	0.014		0.022
F	0.8		1.05	0.031		0.041
F1	1		1.4	0.039		0.055
G	3.2	3.4	3.6	0.126	0.134	0.142
G1	6.6	6.8	7	0.260	0.268	0.276
H2			10.4			0.409
H3	10.05		10.4	0.396		0.409
L	14.2		15	0.559		0.590
L1	5.7		6.2			0.244
L2	14.6		15.2			0.598
L3	3.5		4.1	0.137		0.161
L5	2.6		3	0.102		0.118
L6	15.1		15.8	0.594		0.622
L7	6		6.6	0.236		0.260
Diam.	3.65		3.85	0.144		0.152

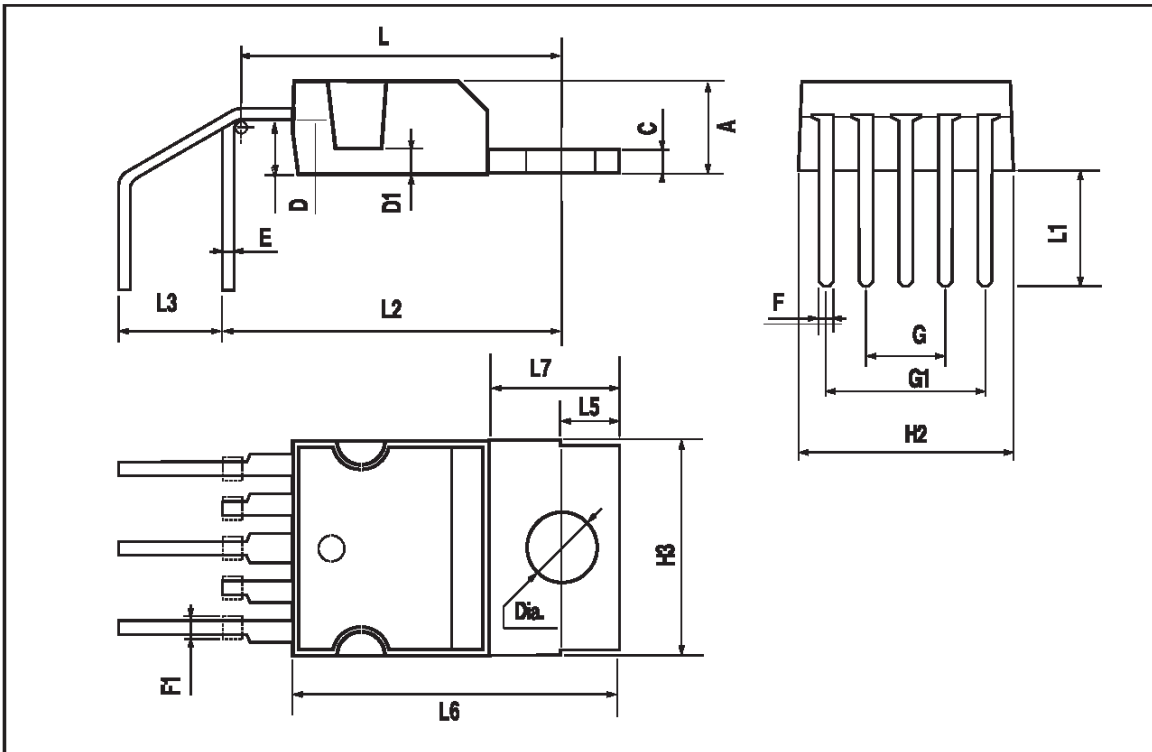

**PENTAWATT (VERTICAL) MECHANICAL DATA**

DIM.	mm.			inch		
	MIN.	TYP	MAX.	MIN.	TYP.	MAX.
A			4.8			0.189
C			1.37			0.054
D	2.4		2.8	0.094		0.110
D1	1.2		1.35	0.047		0.053
E	0.35		0.55	0.014		0.022
F	0.8		1.05	0.031		0.041
F1	1		1.4	0.039		0.055
G	3.2	3.4	3.6	0.126	0.134	0.142
G1	6.6	6.8	7	0.260	0.268	0.276
H2			10.4			0.409
H3	10.05		10.4	0.396		0.409
L		17.85			0.703	
L1		15.75			0.620	
L2		21.4			0.843	
L3		22.5			0.886	
L5	2.6		3	0.102		0.118
L6	15.1		15.8	0.594		0.622
L7	6		6.6	0.236		0.260
M		4.5			0.177	
M1		4			0.157	
Diam.	3.65		3.85	0.144		0.152

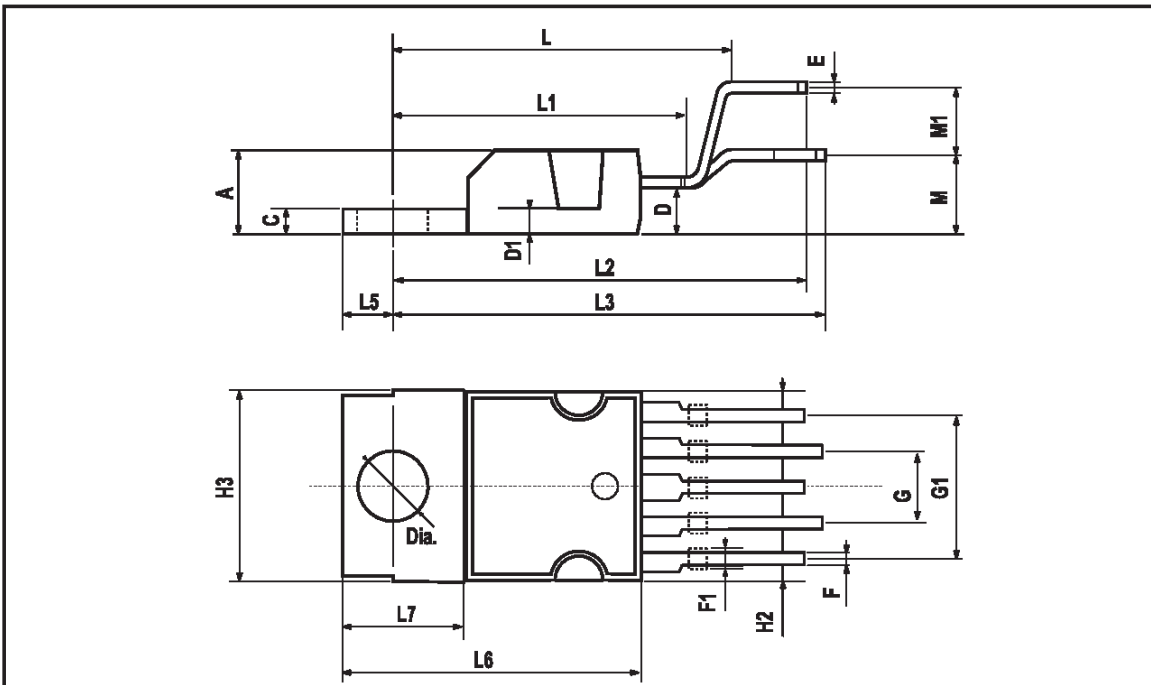

Information furnished is believed to be accurate and reliable. However, STMicroelectronics assumes no responsibility for the consequences of use of such information nor for any infringement of patents or other rights of third parties which may result from its use. No license is granted by implication or otherwise under any patent or patent rights of STMicroelectronics. Specifications mentioned in this publication are subject to change without notice. This publication supersedes and replaces all information previously supplied. STMicroelectronics products are not authorized for use as critical components in life support devices or systems without express written approval of STMicroelectronics.

The ST logo is a trademark of STMicroelectronics

© 1999 STMicroelectronics - Printed in ITALY- All Rights Reserved.

STMicroelectronics GROUP OF COMPANIES

Australia - Brazil - Canada - China - France - Germany - Italy - Japan - Korea - Malaysia - Malta - Mexico - Morocco -  
The Netherlands - Singapore - Spain - Sweden - Switzerland - Taiwan - Thailand - United Kingdom - U.S.A.

<http://www.st.com>