

High side driver

Features

Type	$R_{DS(on)}$	I_{out}	V_{CC}
VN751PT	60 m Ω	2.5 A	36 V

- CMOS compatible input
- Thermal shutdown
- Shorted load protection
- Undervoltage and overvoltage shutdown
- Protection against loss of ground
- Very low stand-by current
- Compliance to 61000-4-4 IEC test up to 4 kV

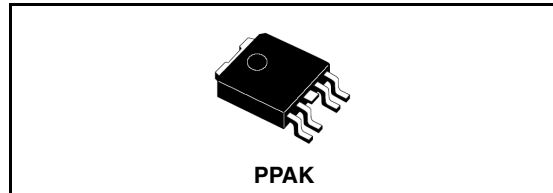

Description

The VN751PT is a monolithic device designed in STMicroelectronics VIPower M0-3 technology, intended for driving any kind of load with one side connected to ground. Active V_{CC} pin voltage clamp protects the device against low energy spikes. Active current limitation combined with thermal shutdown and automatic restart protect the device against overload. Device automatically turns off in case of ground pin disconnection. This device is especially suitable for industrial applications in conformity with IEC 61131-2 programmable controllers international standard.

Figure 1. Block diagram

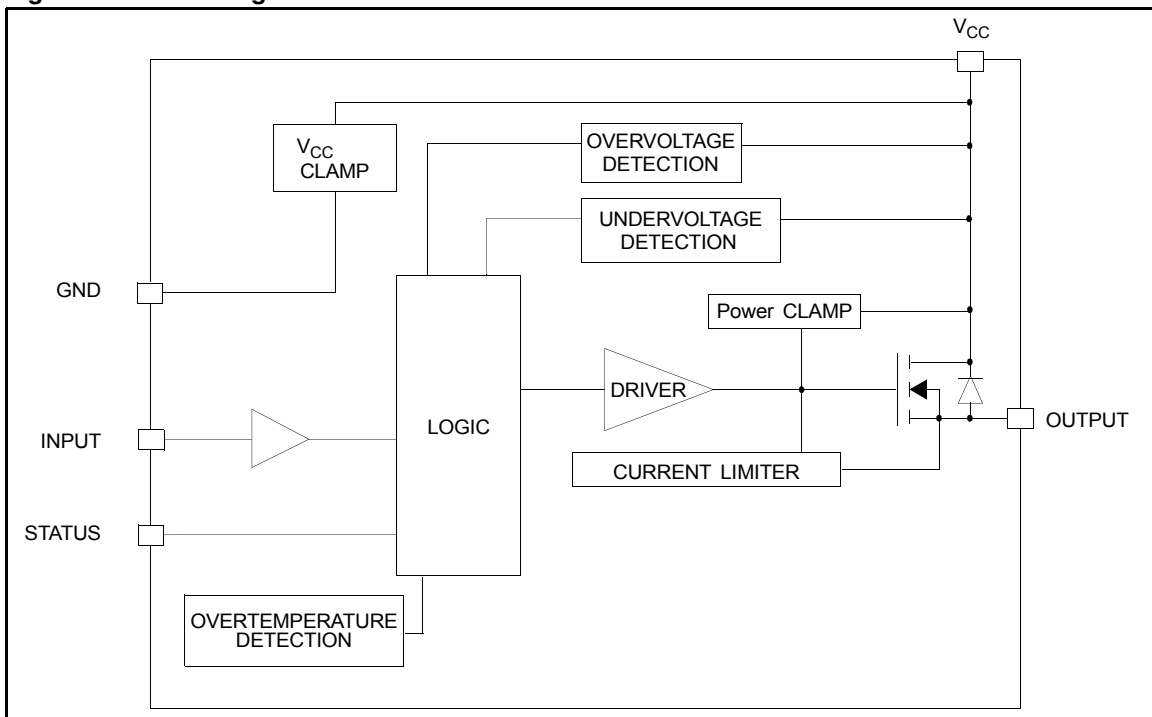

Contents

1	Maximum ratings	3
2	Pin connections	4
3	Electrical characteristics	5
4	Waveforms and truth table	7
5	Test circuit	9
6	Application schematic	10
7	Reverse polarity protection	11
8	Package mechanical data	12
9	Order code	14
10	Revision history	15

1 Maximum ratings

Table 1. Absolute maximum rating

Symbol	Parameter	Value	Unit
V_{CC}	DC supply voltage (overvoltage protected)	45	V
$-V_{CC}$	Reverse DC supply voltage	-0.3	V
$-I_{GND}$	DC reverse ground pin current	-200	mA
I_{OUT}	DC output current	Internally limited	A
$-I_{OUT}$	Reverse DC output current	-5	A
I_{IN}	DC input current	+/- 10	mA
I_{STAT}	DC status current	+/- 10	mA
V_{ESD}	Electrostatic discharge (R = 1.5 k Ω ; C = 100 pF)	5000	V
P_{tot}	Power dissipation $T_C = 25\text{ }^\circ\text{C}$	Internally limited	W
T_J	Junction operating temperature	Internally limited	$^\circ\text{C}$
T_C	Case operating temperature	- 40 to 150	$^\circ\text{C}$
T_{stg}	Storage temperature	- 55 to 150	$^\circ\text{C}$
E_{AS}	Single-pulse avalanche energy	0.8	J

Table 2. Thermal data

Symbol	Parameter	Value	Unit
R_{thJA}	Thermal resistance junction-ambient ⁽¹⁾ Max	50	$^\circ\text{C/W}$
R_{thJC}	Thermal resistance junction-case Max	3	$^\circ\text{C/W}$

1. When mounted on a FR4 printed circuit board with 0.5 cm² of Cu (at least 35 μm thick) connected to all V_{CC} pins.

2 Pin connections

Figure 2. Connection diagram (top view)

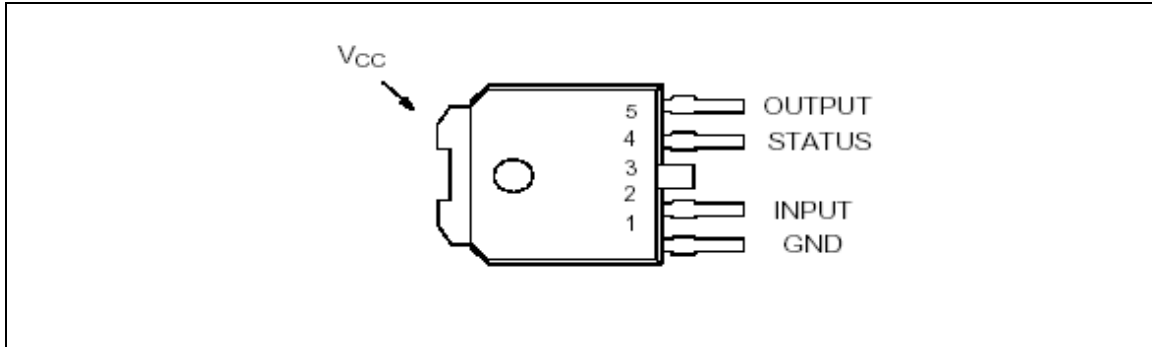
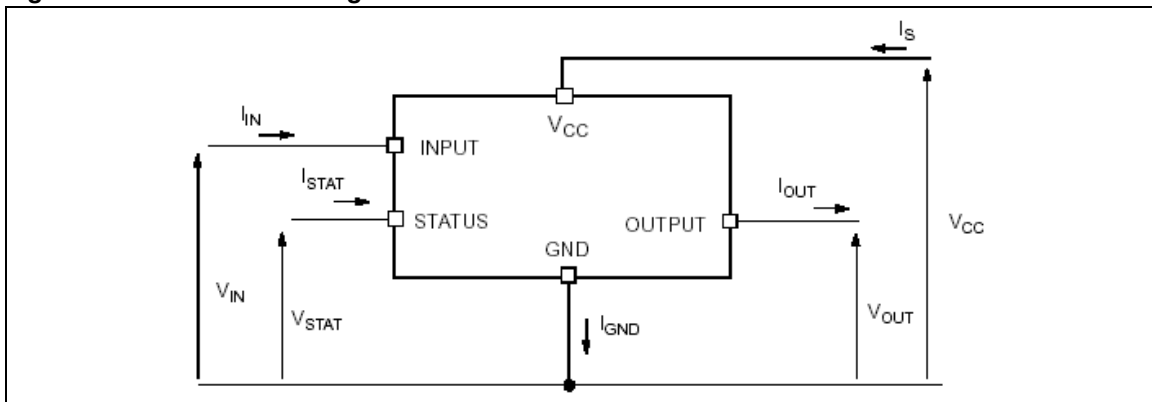

Figure 3. Current and voltage conventions



3 Electrical characteristics

8 V < V_{CC} < 36 V; -40 °C < T_J < 125 °C unless otherwise specified

Table 3. Power

Symbol	Parameter	Test conditions	Min	Typ	Max	Unit
V _{CC}	Operating supply voltage		5.5		36	V
V _{USD}	Undervoltage shut-down		3	4	5.5	V
V _{OV}	Overvoltage shut-down		36			V
R _{ON}	On state resistance	I _{OUT} = 2 A; T _J = 25 °C I _{OUT} = 2 A		60	180	mΩ mΩ
I _S	Supply current	Off State; V _{CC} = 24 V; T _{CASE} = 25 °C On State; V _{CC} = 24 V On State; V _{CC} = 24 V; T _{CASE} = 100 °C		10 1.5	20 1.8	μA mA mA
I _{L(off)}	OFF state output current	V _{IN} = V _{OUT} = 0V	0		10	μA

Table 4. Switching (V_{CC} = 24 V)

Symbol	Parameter	Test conditions	Min	Typ	Max	Unit
t _{d(on)}	Turn-on delay time	R _L =12 Ω from V _{IN} rising edge to V _{OUT} = 2.4 V		12		μs
t _{d(off)}	Turn-off delay time	R _L =12 Ω from V _{IN} falling edge to V _{OUT} = 21.6 V		35		μs
dV _{OUT} /dt _(on)	Turn-on voltage slope	R _L = 12 Ω from V _{OUT} = 2.4 V to V _{OUT} = 19.2 V		0.80		V/μs
dV _{OUT} /dt _(off)	Turn-off voltage slope	R _L = 12 Ω from V _{OUT} = 21.6 V to V _{OUT} = 2.4 V		0.30		V/μs

Table 5. Input pin

Symbol	Parameter	Test conditions	Min	Typ	Max	Unit
V_{IL}	Input low level				1.25	V
I_{IL}	Low level input current	$V_{IN} = 1.25$ V	1			μ A
V_{IH}	Input high level		3.25			V
I_{IH}	High level input current	$V_{IN} = 3.25$ V			10	μ A
V_{hyst}	Input hysteresis voltage		0.5			V
I_{IN}	Input current	$V_{IN} = V_{CC} = 5$ V			10	μ A
V_{ICL}	Input clamp voltage	$I_{IN} = 1$ mA $I_{IN} = -1$ mA	6	6.8 -0.7	8	V V

Table 6. Status pin

Symbol	Parameter	Test conditions	Min	Typ	Max	Unit
V_{STAT}	Status low output voltage	$I_{STAT} = 1.6$ mA			0.5	V
I_{LSTAT}	Status leakage current	Normal operation; $V_{STAT} = 5$ V			10	μ A
C_{STAT}	Status pin input capacitance	Normal operation; $V_{STAT} = 5$ V			100	pF
V_{SCL}	Status clamp voltage	$I_{STAT} = 1$ mA; $I_{STAT} = -1$ mA	6	6.8 -0.7	8	V V

Table 7. Protections

Symbol	Parameter	Test conditions	Min	Typ	Max	Unit
T_{TSD}	Shut-down temperature		150	175	200	$^{\circ}$ C
T_R	Reset temperature		135			$^{\circ}$ C
T_{hyst}	Thermal hysteresis		7	20		$^{\circ}$ C
I_{lim}	Current limitation	$V_{CC} = 24$ V, $R_{LOAD} = 10$ m Ω , $t = 0.4$ ms	2.7		6.0	A
V_{demag}	Turn-off output clamp voltage	$R_L = 12$ Ω ; $L = 6$ mH	$V_{CC} - 47$	$V_{CC} - 52$	$V_{CC} - 57$	V

4 Waveforms and truth table

Figure 4. Switching time waveforms

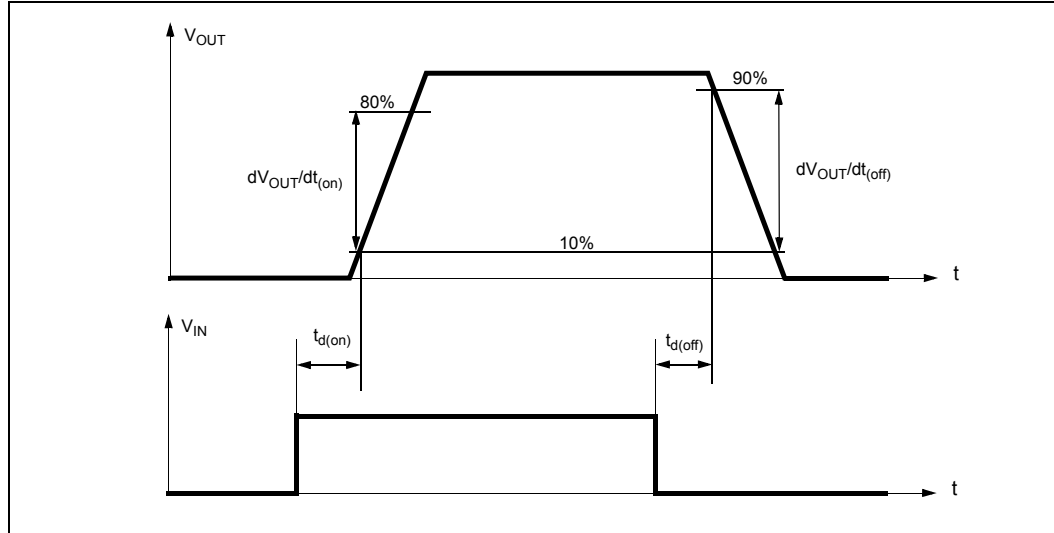
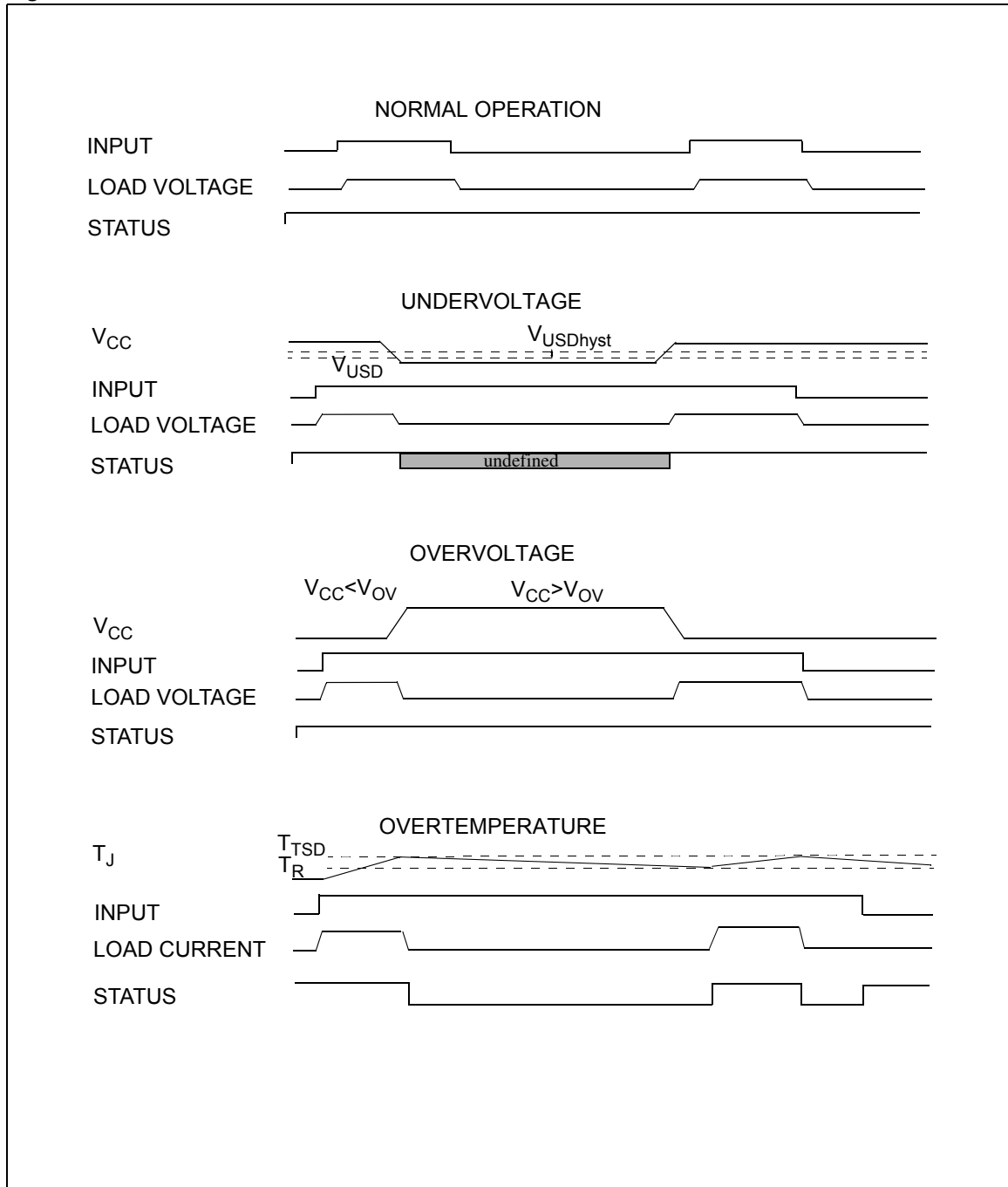

Table 8. Truth table

Conditions	Input	Output	Status
Normal operation	L	L	H
	H	H	H
Current limitation	L	L	H
	H	X	$(T_J < T_{TSD})$ H
	H	X	$(T_J > T_{TSD})$ L
Overtemperature	L	L	H
	H	L	L
Undervoltage	L	L	X
	H	L	X
Overvoltage	L	L	H
	H	L	H

Figure 5. Waveforms



5 Test circuit

Figure 6. Peak short circuit current test circuit

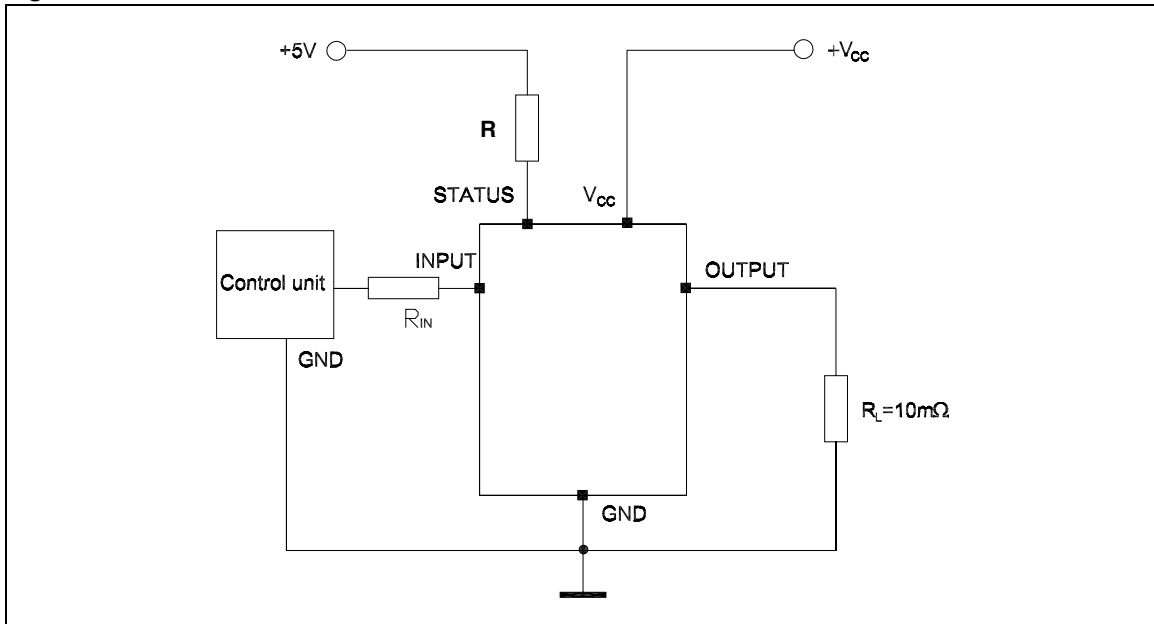
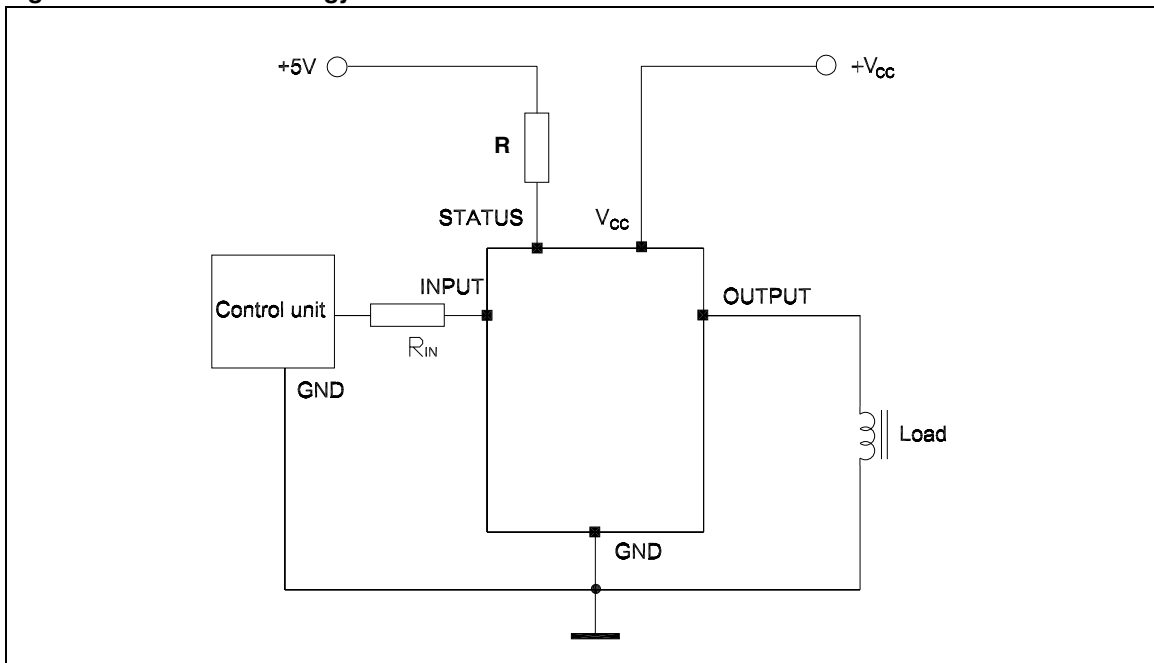
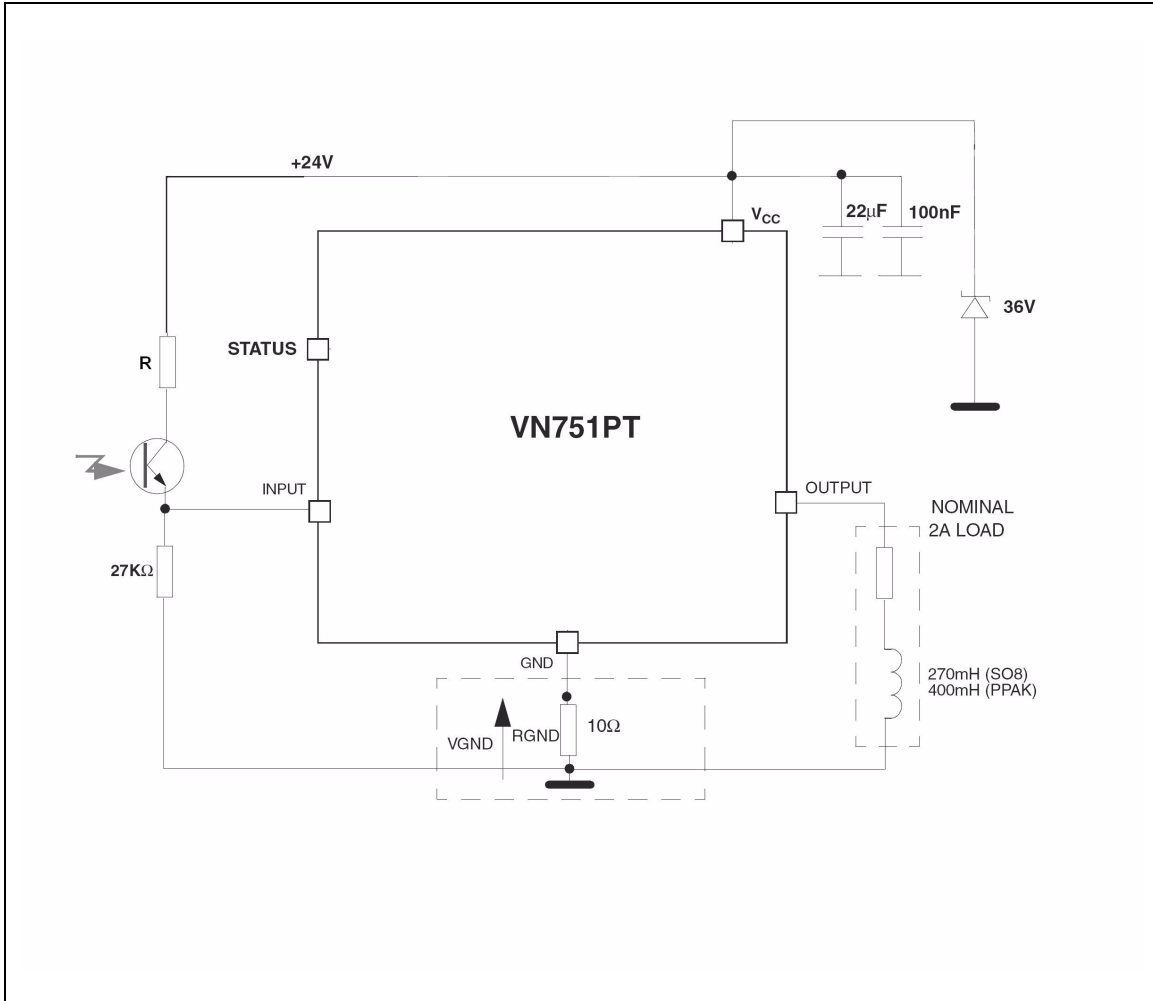

Figure 7. Avalanche energy test circuit



6 Application schematic

Figure 8. Application schematic



7 Reverse polarity protection

A schematic solution to protect the IC against a reverse polarity condition is proposed.

This schematic is effective with any type of load connected to the outputs of the IC.

The R_{GND} resistor value can be selected according to the following conditions to be met:

1. $R_{GND} \leq 600 \text{ mV} / (I_S \text{ in ON state max})$.
2. $R_{GND} \geq (-V_{CC}) / (-I_{GND})$

where $-I_{GND}$ is the DC reverse ground pin current and can be found in the absolute maximum rating section of the device datasheet.

The power dissipation associated to R_{GND} during reverse polarity condition is:

$$PD = (-V_{CC})^2 / R_{GND}$$

This resistor can be shared by several different ICs. In such case I_S value on formula (1) is the sum of the maximum ON-state currents of the different devices.

Please note that if the microprocessor ground and the device ground are separated then the voltage drop across the R_{GND} (given by $I_S \text{ in ON state max} * R_{GND}$) produce a difference between the generated input level and the IC input signal level. This voltage drop will vary depending on how many devices are ON in the case of several high side switches sharing the same R_{GND} .

Figure 9. Reverse polarity protection

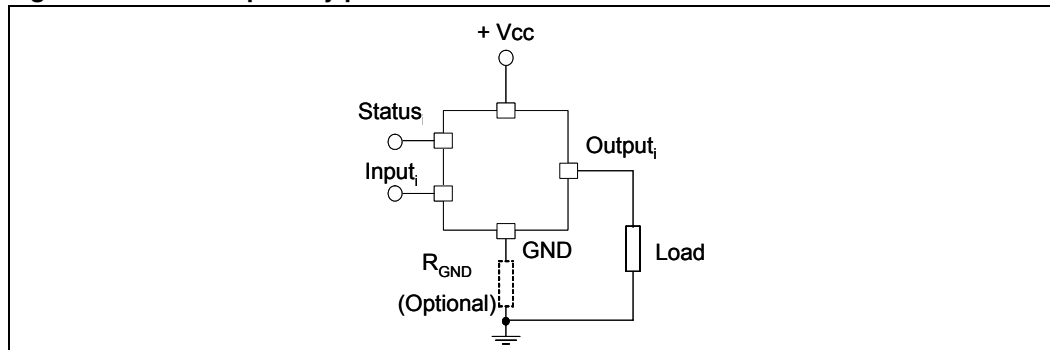

8 Package mechanical data

In order to meet environmental requirements, ST offers these devices in ECOPACK® packages. These packages have a lead-free second level interconnect . The category of second level interconnect is marked on the package and on the inner box label, in compliance with JEDEC Standard JESD97. The maximum ratings related to soldering conditions are also marked on the inner box label. ECOPACK is an ST trademark. ECOPACK specifications are available at: www.st.com

Table 9. PPAK mechanical data

Dim.	Min	Typ	Max
A	2.20		2.40
A1	0.90		1.10
A2	0.03		0.23
B	0.40		0.60
B2	5.20		5.40
C	0.45		0.60
C2	0.48		0.60
D1		5.1	
D	6.00		6.20
E	6.40		6.60
E1		4.7	
e		1.27	
G	4.90		5.25
G1	2.38		2.70
H	9.35		10.10
L2		0.8	1.00
L4	0.60		1.00
R		0.2	
V2	0°		8°
Package weight	Gr. 0.3		

Figure 10. Package dimensions

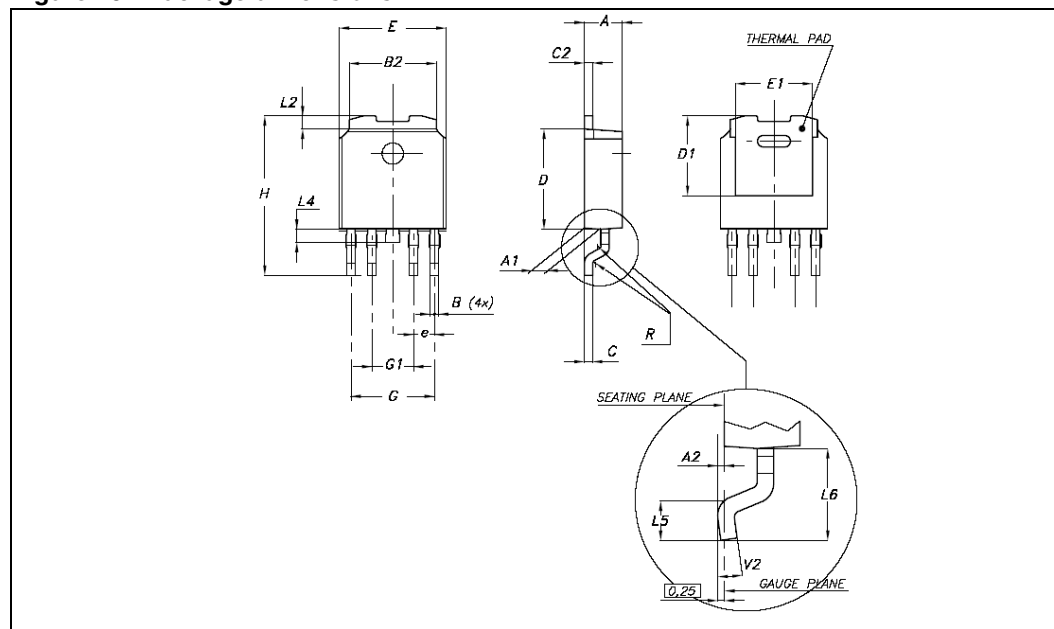

9 Order code

Table 10. Order codes

Order codes	Package	Packaging
VN751PT	PPAK	Tube
VN751PT13TR	PPAK	Tape and reel

10 Revision history

Table 11. Document revision history

Date	Revision	Changes
07-Mar-2006	1	Initial release
31-Mar-2006	2	Added V_{SCL}
10-Jul-2006	3	Updated V_{CC} value Table 1 , I_{lim} min value Table 7
12-Mar-2007	4	Typo in Table 4 on page 5 , updated P_{tot} value Table 1 .
15-May-2007	5	Typo in Table 1 on page 3 , V_{ESD}
18-Sep-2007	6	Added I_{STAT} value in Table 1 on page 3
08-Jul-2008	7	Added Section 7 on page 11

Please Read Carefully:

Information in this document is provided solely in connection with ST products. STMicroelectronics NV and its subsidiaries ("ST") reserve the right to make changes, corrections, modifications or improvements, to this document, and the products and services described herein at any time, without notice.

All ST products are sold pursuant to ST's terms and conditions of sale.

Purchasers are solely responsible for the choice, selection and use of the ST products and services described herein, and ST assumes no liability whatsoever relating to the choice, selection or use of the ST products and services described herein.

No license, express or implied, by estoppel or otherwise, to any intellectual property rights is granted under this document. If any part of this document refers to any third party products or services it shall not be deemed a license grant by ST for the use of such third party products or services, or any intellectual property contained therein or considered as a warranty covering the use in any manner whatsoever of such third party products or services or any intellectual property contained therein.

UNLESS OTHERWISE SET FORTH IN ST'S TERMS AND CONDITIONS OF SALE ST DISCLAIMS ANY EXPRESS OR IMPLIED WARRANTY WITH RESPECT TO THE USE AND/OR SALE OF ST PRODUCTS INCLUDING WITHOUT LIMITATION IMPLIED WARRANTIES OF MERCHANTABILITY, FITNESS FOR A PARTICULAR PURPOSE (AND THEIR EQUIVALENTS UNDER THE LAWS OF ANY JURISDICTION), OR INFRINGEMENT OF ANY PATENT, COPYRIGHT OR OTHER INTELLECTUAL PROPERTY RIGHT.

UNLESS EXPRESSLY APPROVED IN WRITING BY AN AUTHORIZED ST REPRESENTATIVE, ST PRODUCTS ARE NOT RECOMMENDED, AUTHORIZED OR WARRANTED FOR USE IN MILITARY, AIR CRAFT, SPACE, LIFE SAVING, OR LIFE SUSTAINING APPLICATIONS, NOR IN PRODUCTS OR SYSTEMS WHERE FAILURE OR MALFUNCTION MAY RESULT IN PERSONAL INJURY, DEATH, OR SEVERE PROPERTY OR ENVIRONMENTAL DAMAGE. ST PRODUCTS WHICH ARE NOT SPECIFIED AS "AUTOMOTIVE GRADE" MAY ONLY BE USED IN AUTOMOTIVE APPLICATIONS AT USER'S OWN RISK.

Resale of ST products with provisions different from the statements and/or technical features set forth in this document shall immediately void any warranty granted by ST for the ST product or service described herein and shall not create or extend in any manner whatsoever, any liability of ST.

ST and the ST logo are trademarks or registered trademarks of ST in various countries.

Information in this document supersedes and replaces all information previously supplied.

The ST logo is a registered trademark of STMicroelectronics. All other names are the property of their respective owners.

© 2008 STMicroelectronics - All rights reserved

STMicroelectronics group of companies

Australia - Belgium - Brazil - Canada - China - Czech Republic - Finland - France - Germany - Hong Kong - India - Israel - Italy - Japan - Malaysia - Malta - Morocco - Singapore - Spain - Sweden - Switzerland - United Kingdom - United States of America

www.st.com