



# ST890B ST890C, ST890D

## 1.2 A current limited high side power switch with thermal shutdown

### Features

- 2.7 V to 5.5 V input range
- Programmable current limit up to 1.2 A
- Low quiescent current
- Thermal shutdown
- Active low  $\overline{\text{FAULT}}$  indicator output
- 90 m $\Omega$  (typ.) ON resistance
- SO-8 and DFN8L (3 x 3 mm) packages

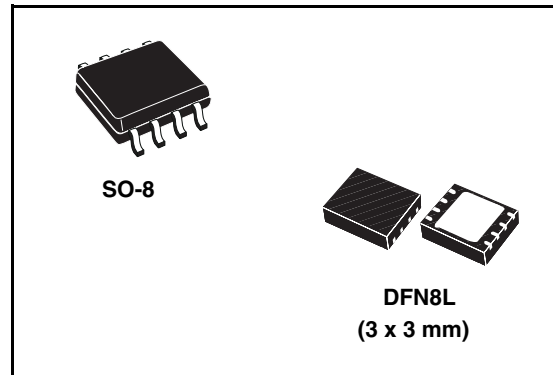

### Applications

- PCMCIA slots
- Access bus slots
- Portable equipment

### Description

The ST890B, ST890C and ST890D are low voltage, P-channel MOSFET power switches intended for high side load switching applications.

These switches operate with inputs from 2.7 V to 5.5 V, making it ideal for both 3 V and 5 V systems.

The internal current limiting circuitry protects the input supply against overload. The thermal overload protection limits power dissipation and junction temperatures.

The maximum current limit is 1.2 A. The current limit through the switch is programmed with a resistor from SET to ground. The devices are available in SO-8 and DFN8L (3 x 3 mm) packages.

**Table 1. Device summary**

Order code	Package	Packaging
ST890BDR	SO-8	2500 parts per reel
ST890CDR	SO-8	2500 parts per reel
ST890DTR	DFN8L (3 x 3 mm)	3000 parts per reel

## Contents

<b>1</b>	<b>Device summary</b> .....	<b>3</b>
<b>2</b>	<b>Maximum rating</b> .....	<b>6</b>
	2.1 Typical performance characteristics .....	9
<b>3</b>	<b>Package mechanical data</b> .....	<b>11</b>
<b>4</b>	<b>Revision history</b> .....	<b>16</b>

# 1 Device summary

Figure 1. SO-8 pin connection (top view)

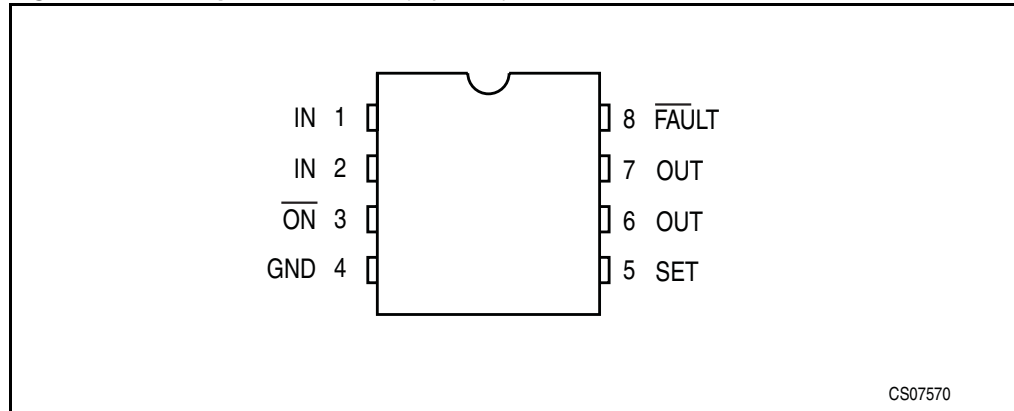
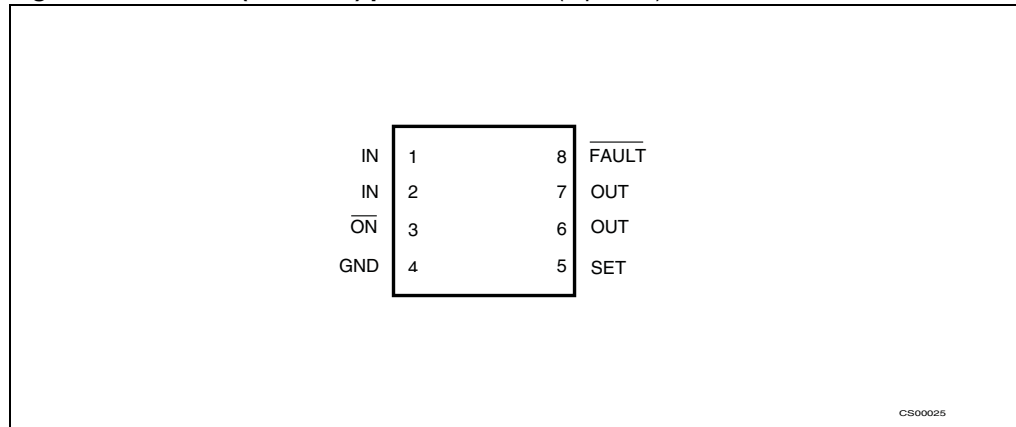

Table 2. SO-8 pin description

Pin N.	Symbol	Name and function
1, 2	IN	Input P-channel MOSFET source. Bypass IN with a 1 $\mu$ F capacitor to ground
3	$\overline{\text{ON}}$	Active low switch ON input. A logic low turns the switch ON
4	GND	Ground
5	SET	Set current limit input. A resistor from SET to GND sets the current limit for the switch. $R_{\text{SET}} = 1.38 \times 10^3 / I_{\text{LIM}}$ , where $I_{\text{LIM}}$ is the desired current limit in Amperes
6,7	OUT	Switch output. P-channel MOSFET drain. Bypass OUT with a 0.1 $\mu$ F capacitor to ground
8	$\overline{\text{FAULT}}$	Fault indicator output. This open drain output goes low when in current limit or when the die temperature exceeds 135°C

**Figure 2. DFN8L (3 x 3 mm) pin connection (top view)****Table 3. DFN8L (3 x 3 mm) pin description**

Pin N.	Symbol	Name and function
1, 2	IN	Input P-channel MOSFET source. Bypass IN with a 1 $\mu$ F capacitor to ground
3	$\overline{\text{ON}}$	Active low switch ON input. A logic low turns the switch ON
4	GND	Ground
5	SET	Set current limit input. A resistor from SET to GND sets the current limit for the switch.
6,7	OUT	Switch output. P-channel MOSFET drain. Bypass OUT with a 0.1 $\mu$ F capacitor to ground
8	$\overline{\text{FAULT}}$	Fault indicator output. This open drain output goes low when in current limit or when the die temperature exceeds 135 $^{\circ}$ C

Figure 3. Schematic diagram

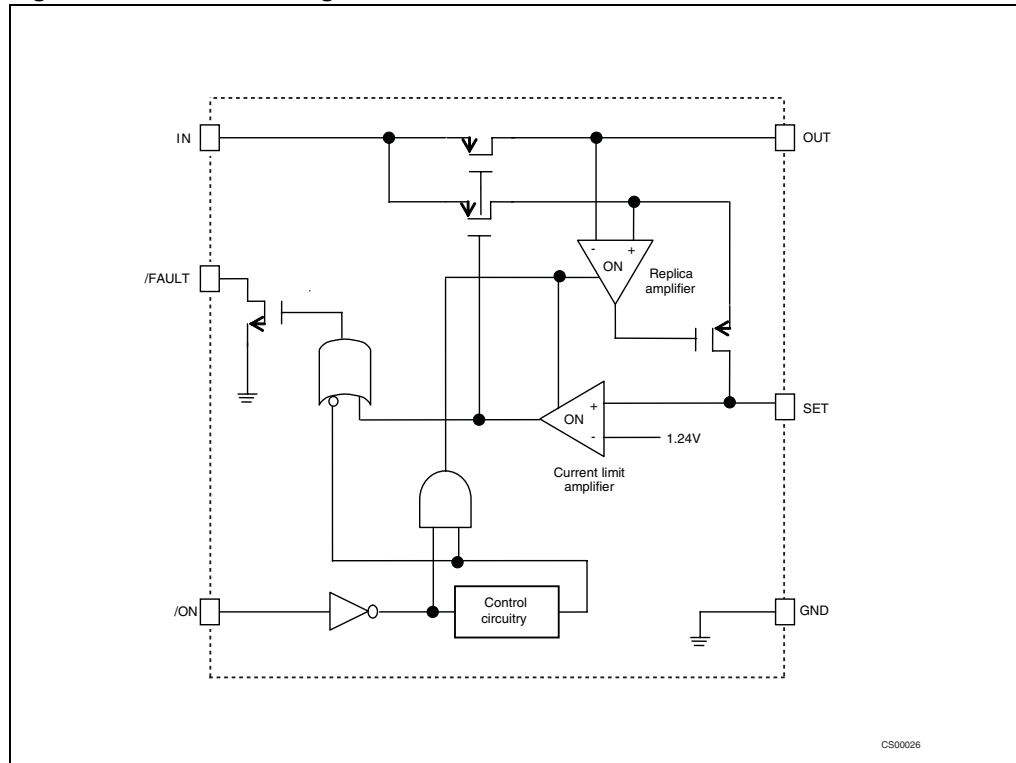

Table 4. Truth table for  $\overline{\text{ON}}/\text{OFF}$  switch

$\overline{\text{ON}}/\text{OFF}$	OUT
L	ON
H	OFF

Table 5. Truth table for  $\overline{\text{FAULT}}$

FAULT	FLAG
H	Normal operation
L	Fault condition

## 2 Maximum rating

Stressing the device above the rating listed in the “Absolute maximum ratings” table may cause permanent damage to the device. These are stress ratings only and operation of the device at these or any other conditions above those indicated in the operating sections of this specification is not implied. Exposure to Absolute maximum rating conditions for extended periods may affect device reliability. Refer also to the STMicroelectronics SURE Program and other relevant quality documents.

**Table 6. Absolute maximum ratings**

Symbol	Parameter	Value	Unit
$V_I$	Supply voltage	-0.5 to +6	V
$V_{ON}$	Input voltage at ON pin	-0.5 to +6	V
$V_{FAULT\_N}$	Input voltage at FAULT_N pin	-0.5 to +6	V
$V_{SET}$	Voltage at SET pin	-0.5 to ( $V_{IN} + 0.5$ )	V
$I_{DS}$	Maximum continuous switching current	1.5	A
$T_{stg}$	Storage temperature	-65 to +150	°C
$T_{op}$	Operating junction temperature range	-40 to +85	°C

**Table 7. Thermal data**

Symbol	Parameter	SO-8	DFN8L	Unit
$R_{thj-amb}$	Thermal resistance junction-ambient	160 <sup>(1)</sup>	37.6 <sup>(2)</sup>	°C/W

1. This value depends from thermal design of PCB on which the device is mounted.

2. This value depends from the 4-layer PCB, JEDEC standard test board.

**Table 8. Electrical characteristics**

Symbol	Parameter	Test condition <sup>(1)</sup>	Value			Unit
			$T_A = 25^\circ\text{C}$			
			Min	Typ	Max	
$V_I$	Operating voltage	$I_D = 1\text{ mA}$	2.7		5.5	V
$I_{CC}$	ON quiescent supply current	$V_I = 5\text{ V}$ , $\overline{ON} = \text{GND}$ $IO = 0$		13	25	$\mu\text{A}$
$I_{(CCOFF)}$	OFF quiescent supply current	$\overline{ON} = \text{IN}$ $V_I = V_{OUT} = 5.5\text{ V}$			1	$\mu\text{A}$
		$\overline{ON} = \text{IN}$ $V_I = 5.5\text{ V}$ $V_O = 0$			5	

Table 8. Electrical characteristics (continued)

Symbol	Parameter	Test condition <sup>(1)</sup>	Value			Unit
			T <sub>A</sub> = 25°C			
			Min	Typ	Max	
V <sub>ULO</sub>	Undervoltage lockout	Rising edge	2.0	2.4	2.6	V
V <sub>HYST</sub>	Undervoltage lockout hysteresis			100		mV
R <sub>ON</sub>	ON resistance	V <sub>I</sub> = 4.5 V		75	120	mΩ
		V <sub>I</sub> = 3 V		90	130	mΩ
V <sub>SET</sub>	Reference voltage to turn the switch OFF	I <sub>O</sub> = 100 mA V <sub>SET</sub> rise until V <sub>I</sub> - V <sub>O</sub> > 0.8V	1.178	1.24	1.302	V
I <sub>MAX</sub>	Maximum programmable output over current limit			1.2		A
I <sub>SC</sub>	Short circuit current limit	V <sub>I</sub> = 5V, OUT connected to GND, device enabled into short circuit		1.2 I <sub>LIM</sub>	1.5 I <sub>LIM</sub>	A
I <sub>LIM</sub> /I <sub>SET</sub>	I <sub>LIM</sub> to I <sub>SET</sub> current ratio	I <sub>O</sub> = 500 mA V <sub>O</sub> > 1.6 V	970	1110	1300	
V <sub>IL</sub>	ON input low level voltage	V <sub>I</sub> = 2.7 to 5.5 V			0.8	V
V <sub>IH</sub>	ON input high level voltage	V <sub>I</sub> = 2.7 to 3.6 V	2.0			V
		V <sub>I</sub> = 2.7 to 5.5 V	2.4			V
I <sub>I</sub>	ON input leakage current	V <sub>I</sub> = 5.5 V			1	μA
I <sub>SET</sub> bias	I <sub>SET</sub> bias current	V <sub>SET</sub> = 1.24 V I <sub>O</sub> = 0A V <sub>I</sub> = V <sub>O</sub>		0.5	3	μA
V <sub>OL</sub>	$\overline{\text{FAULT}}$ output low voltage	I <sub>SINK</sub> = 1 mA V <sub>SET</sub> = 1.4 V		0.15		V
I <sub>OH</sub>	$\overline{\text{FAULT}}$ output high voltage	V <sub>FAULT</sub> = 5.5 V V <sub>SET</sub> = 1 V			1	μA
T <sub>PROT</sub>	Thermal protection			130		°C
T <sub>HYST</sub>	Thermal hysteresis			15		°C

1. V<sub>IN</sub> = 3 V, T<sub>A</sub> = T<sub>MIN</sub> to T<sub>MAX</sub>, unless otherwise specified. Typical values are at T<sub>A</sub> = 25°C

**Table 9. Timing characteristics**

Symbol	Parameter	Test condition <sup>(1)</sup>	Value			Unit
			T <sub>A</sub> = 25°C			
			Min	Typ	Max	
t <sub>RESP</sub>	Slow current loop response time	20% current overdrive, V <sub>CC</sub> = 5 V		5		μs
	Fast current loop response time			2		μs
t <sub>ON</sub>	Turn ON time	V <sub>I</sub> = 5 V I <sub>O</sub> = 500 mA		25	50	μs
		V <sub>I</sub> = 3 V I <sub>O</sub> = 500 mA		50		μs
t <sub>OFF</sub>	Turn OFF time	V <sub>I</sub> = 5 V	1	2	10	μs

1. V<sub>IN</sub> = 3 V, T<sub>A</sub> = T<sub>MIN</sub> to T<sub>MAX</sub>, unless otherwise specified. Typical values are at T<sub>A</sub> = 25 °C

**Figure 4. Typical application circuit**

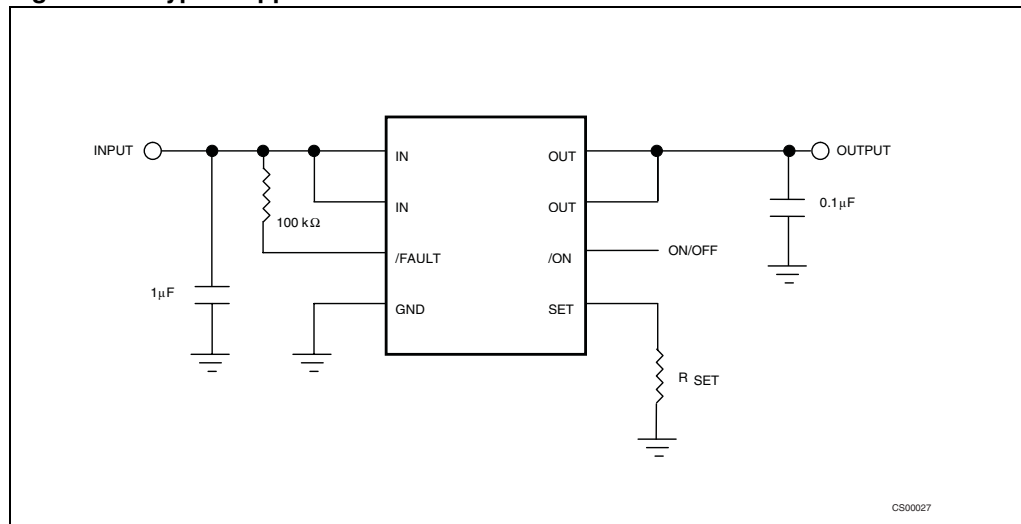



## 2.1 Typical performance characteristics

Unless otherwise specified  $T_j = 25\text{ }^\circ\text{C}$ .

**Figure 5. ON resistance vs. supply voltage**

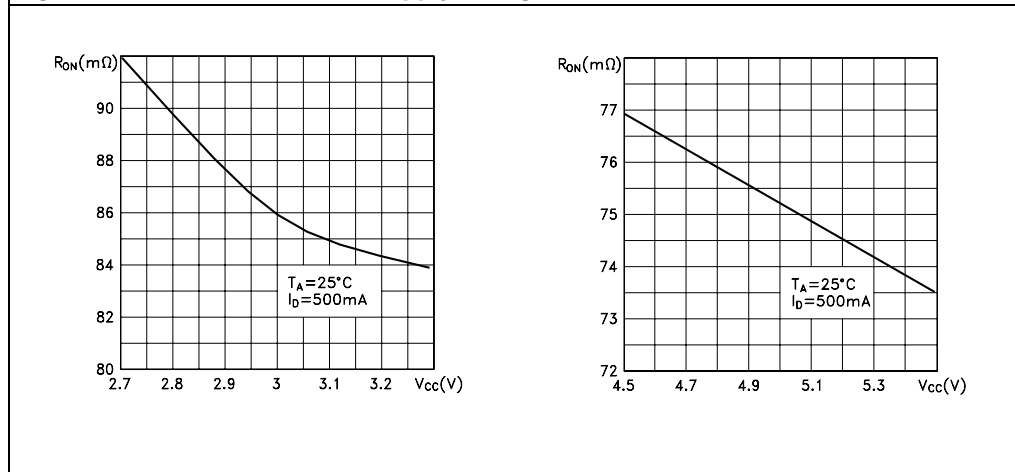

**Figure 6. ON resistance vs. temperature**

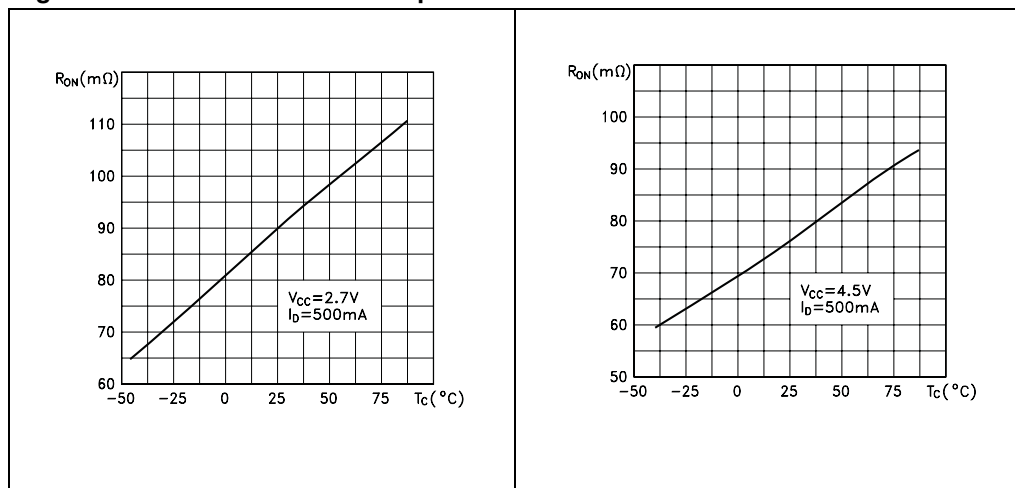
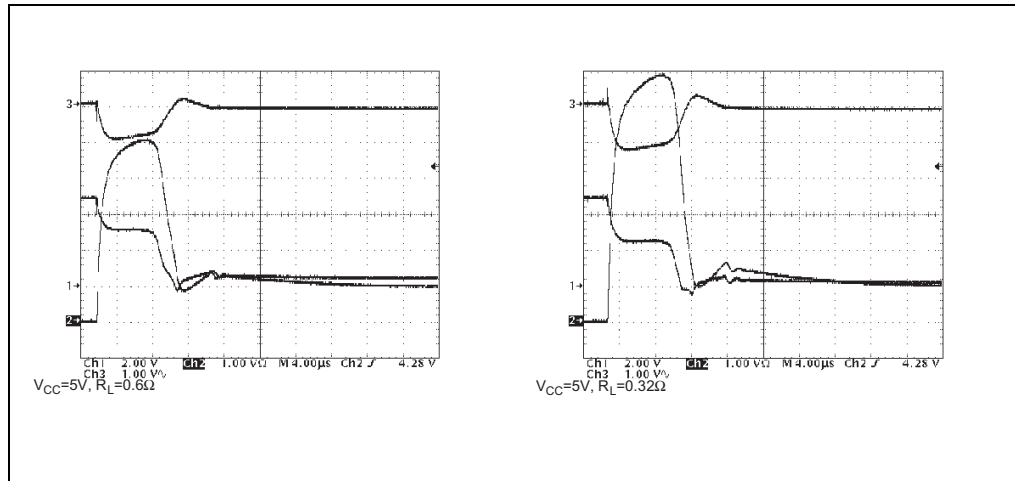

Figure 7. Switching waveforms



### 3 Package mechanical data

In order to meet environmental requirements, ST offers these devices in ECOPACK<sup>®</sup> packages. These packages have a Lead-free second level interconnect. The category of second level interconnect is marked on the package and on the inner box label, in compliance with JEDEC Standard JESD97. The maximum ratings related to soldering conditions are also marked on the inner box label. ECOPACK is an ST trademark. ECOPACK specifications are available at: [www.st.com](http://www.st.com).

Figure 8. SO-8 package drawing

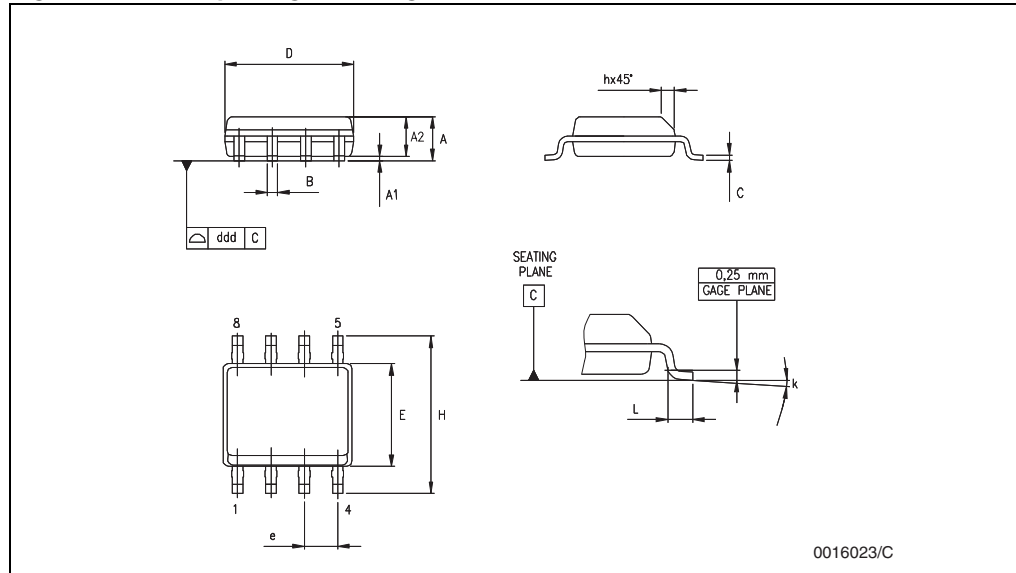

1. Drawing not to scale.

Table 10. SO-8 package mechanical data

Symbol	millimeters			inches		
	Min	Typ	Max	Min	Typ	Max
A	1.35		1.75	0.053		0.069
A1	0.10		0.25	0.04		0.010
A2	1.10		1.65	0.043		0.065
B	0.33		0.51	0.013		0.020
C	0.19		0.25	0.007		0.010
D	4.80		5.00	0.189		0.197
E	3.80		4.00	0.150		0.157
e		1.27			0.050	
H	5.80		6.20	0.228		0.244
h	0.25		0.50	0.010		0.020
L	0.40		1.27	0.016		0.050
k	$8^{\circ}(\text{max})$					
ddd			0.1			0.04

Figure 9. SO-8 tape and reel specifications

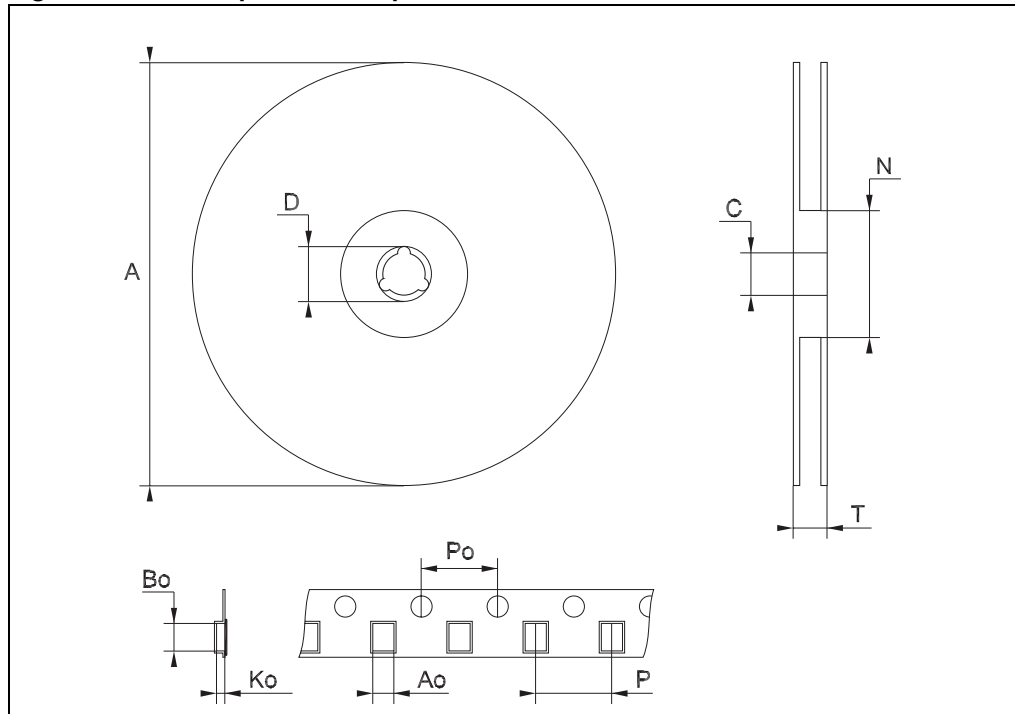

1. Drawing not to scale.

Table 11. SO-8 tape and reel mechanical data

Symbol	millimeters			inches		
	Min	Typ	Max	Min	Typ	Max
A			330			12.992
C	12.8		13.2	0.504		0.519
D	20.2			0.795		
N	60			2.362		
T			22.4			0.882
Ao	8.1		8.5	0.319		0.335
Bo	5.5		5.9	0.216		0.232
Ko	2.1		2.3	0.082		0.090
Po	3.9		4.1	0.153		0.161
P	7.9		8.1	0.311		0.319

Figure 10. DFN8L (3 x 3 mm) package drawing

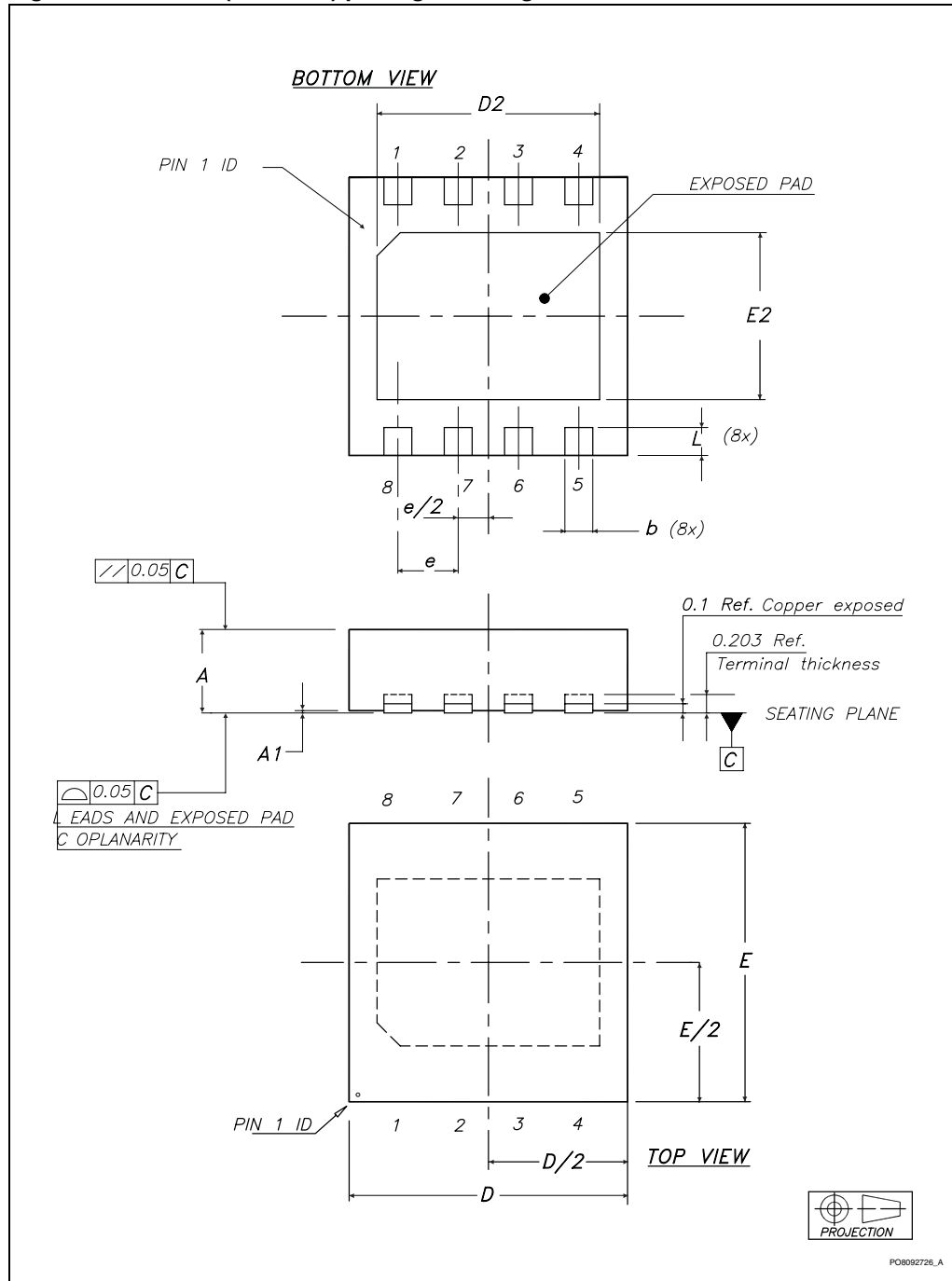

1. Drawing is not to scale.
2. Dimensions in millimeters.

Table 12. DFN8L (3 x 3 mm) package mechanical data

Symbol	millimeters		
	Min	Typ	Max
A	0.80	0.85	0.90
A1	0	0.02	0.05
b	0.25	0.030	0.35
D	2.95	3	3.05
D2	2.30	2.40	2.50
E	2.95	3	3.05
E2	1.70	1.80	1.90
e		0.65	
L	0.25	0.30	0.35

Figure 11. DFN8L (3 x 3 mm) footprint recommendations

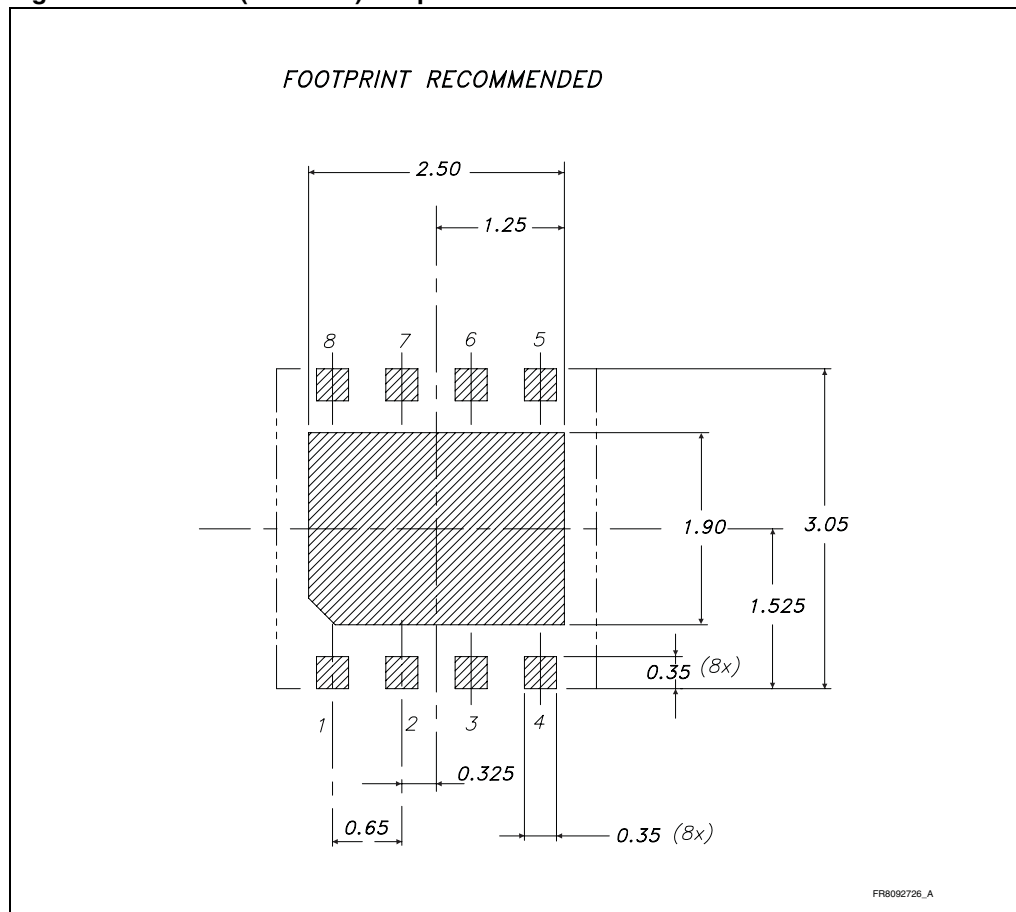

1. Drawing not to scale.
2. Dimensions in millimeters.

## 4 Revision history

Table 13. Document revision history

Date	Revision	Changes
22-Jul-2005	4	Added 3 rows on <a href="#">Table 2 on page 3</a>
10-Aug-2007	5	Removed ST890CD and ST890BD from <a href="#">Table 1 on page 1</a> Updated short circuit current limit value in <a href="#">Table 8 on page 6</a>
1-Dec-2007	6	Added <a href="#">Section : Contents</a> . Added ST890D and related DFN8L package information. Added <a href="#">Figure 2: DFN8L (3 x 3 mm) pin connection (top view) on page 4</a> . <a href="#">Figure 3: Schematic diagram on page 5</a> : redrawn, no content change. Modified title in <a href="#">Table 5: Truth table for FAULT on page 5</a> . Updated <a href="#">Table 8: Electrical characteristics on page 6</a> . <a href="#">Figure 4: Typical application circuit on page 8</a> : redrawn, no content change



**Please Read Carefully:**

Information in this document is provided solely in connection with ST products. STMicroelectronics NV and its subsidiaries ("ST") reserve the right to make changes, corrections, modifications or improvements, to this document, and the products and services described herein at any time, without notice.

All ST products are sold pursuant to ST's terms and conditions of sale.

Purchasers are solely responsible for the choice, selection and use of the ST products and services described herein, and ST assumes no liability whatsoever relating to the choice, selection or use of the ST products and services described herein.

No license, express or implied, by estoppel or otherwise, to any intellectual property rights is granted under this document. If any part of this document refers to any third party products or services it shall not be deemed a license grant by ST for the use of such third party products or services, or any intellectual property contained therein or considered as a warranty covering the use in any manner whatsoever of such third party products or services or any intellectual property contained therein.

**UNLESS OTHERWISE SET FORTH IN ST'S TERMS AND CONDITIONS OF SALE ST DISCLAIMS ANY EXPRESS OR IMPLIED WARRANTY WITH RESPECT TO THE USE AND/OR SALE OF ST PRODUCTS INCLUDING WITHOUT LIMITATION IMPLIED WARRANTIES OF MERCHANTABILITY, FITNESS FOR A PARTICULAR PURPOSE (AND THEIR EQUIVALENTS UNDER THE LAWS OF ANY JURISDICTION), OR INFRINGEMENT OF ANY PATENT, COPYRIGHT OR OTHER INTELLECTUAL PROPERTY RIGHT.**

**UNLESS EXPRESSLY APPROVED IN WRITING BY AN AUTHORIZED ST REPRESENTATIVE, ST PRODUCTS ARE NOT RECOMMENDED, AUTHORIZED OR WARRANTED FOR USE IN MILITARY, AIR CRAFT, SPACE, LIFE SAVING, OR LIFE SUSTAINING APPLICATIONS, NOR IN PRODUCTS OR SYSTEMS WHERE FAILURE OR MALFUNCTION MAY RESULT IN PERSONAL INJURY, DEATH, OR SEVERE PROPERTY OR ENVIRONMENTAL DAMAGE. ST PRODUCTS WHICH ARE NOT SPECIFIED AS "AUTOMOTIVE GRADE" MAY ONLY BE USED IN AUTOMOTIVE APPLICATIONS AT USER'S OWN RISK.**

Resale of ST products with provisions different from the statements and/or technical features set forth in this document shall immediately void any warranty granted by ST for the ST product or service described herein and shall not create or extend in any manner whatsoever, any liability of ST.

ST and the ST logo are trademarks or registered trademarks of ST in various countries.

Information in this document supersedes and replaces all information previously supplied.

The ST logo is a registered trademark of STMicroelectronics. All other names are the property of their respective owners.

© 2007 STMicroelectronics - All rights reserved

STMicroelectronics group of companies

Australia - Belgium - Brazil - Canada - China - Czech Republic - Finland - France - Germany - Hong Kong - India - Israel - Italy - Japan - Malaysia - Malta - Morocco - Singapore - Spain - Sweden - Switzerland - United Kingdom - United States of America

[www.st.com](http://www.st.com)

